

(No Model.)

G. SEARS & W. H. UNDERWOOD.  
POWER SHEARS.

No. 522,622.

Patented July 10, 1894.

Fig. 1.

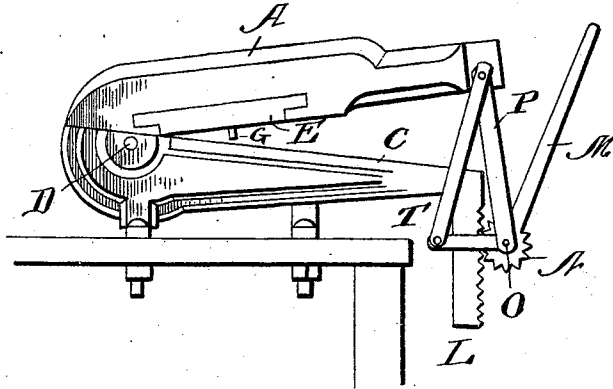

Fig. 2.

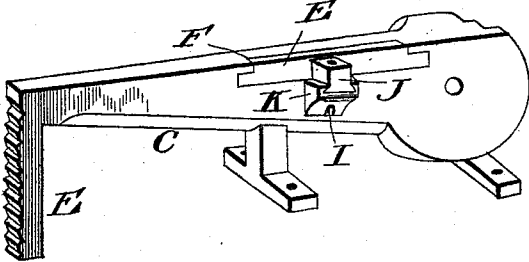

Fig. 3.

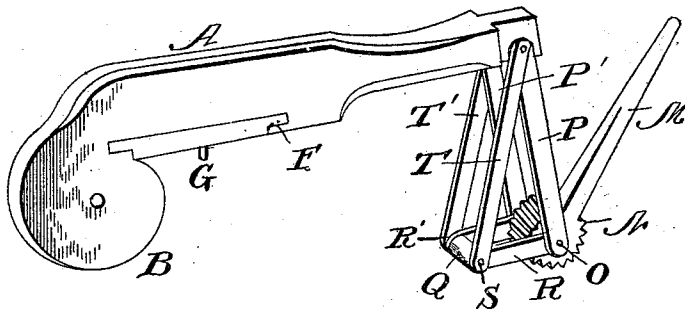
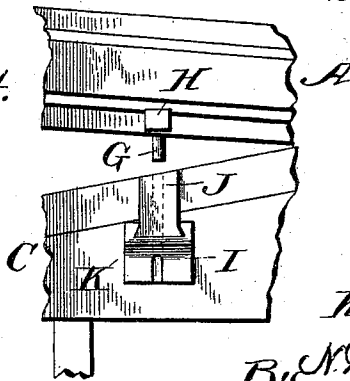

Fig. 4.



Witnesses:

J. B. McGirr.  
M. L. Moran.

Inventors

George Sears  
William H. Underwood

By N. H. Fitz-Gerald & Co.  
Attys

# UNITED STATES PATENT OFFICE.

GEORGE SEARS AND WILLIAM H. UNDERWOOD, OF ONSLOW, IOWA.

## POWER-SHEARS.

SPECIFICATION forming part of Letters Patent No. 522,622, dated July 10, 1894.

Application filed March 18, 1893. Serial No. 466,612. (No model.)

*To all whom it may concern:*

Be it known that we, GEORGE SEARS and WILLIAM H. UNDERWOOD, citizens of the United States of America, residing at Onslow, in the county of Jones and State of Iowa, have invented certain new and useful Improvements in Power-Shears, of which the following is a specification, reference being had therein to the accompanying drawings.

Our invention relates, in general, to power-shears for cutting metal, and more particularly refers to a combined punch and shearer adapted for different metals, and specially designed for trimming metal shovels, punching the same and for cutting and punching bar and sheet steel.

Our invention has for its object to provide an improved form and construction of a device of this class which shall possess increased power facilities, shall comprise removable and reversible cutters detachably fastened to the cutter-jaws in an improved manner, shall include a novel form of punch, shall be durable in use, inexpensive in manufacture and efficient, reliable, and economic in operation. For the attainment of these objects, and for other purposes hereinafter enumerated, this invention consists, in brief, in certain details of construction, arrangement and combination of parts, all of which will be more fully described hereinafter, and the specific points of novelty in which will be designated by the appended claims.

Referring to the accompanying drawings forming a part of this specification:—Figure 1 is a view in side elevation showing the device applied to a work-bench in operative position and the jaws open or distended. Fig. 2 is a detail perspective view of the lower jaw. Fig. 3 is a similar view of the upper jaw looking from the opposite side; and Fig. 4 is a detail view of the punch.

Like letters of reference mark the same or corresponding parts in the several views of the drawings.

A indicates the upper jaw of any desired material, shape, and dimensions to suit requirements. The back of this jaw is curved or rounded as shown; being slightly reduced at its rear extremity and provided at its forward end with the angularly depending bearing enlargement, B.

C is the under or lower jaw substantially similar in shape and dimensions to the upper jaw and is hinged or trunnioned to the forward end of the latter by means of a pivot-pin, D, passing through coincident bearing holes in the lapped forward enlargements of the upper and lower jaws, as clearly indicated in the drawings.

The inner adjacent and meeting edges of the two jaws, A, and C are severally straight edges and are respectively provided with steel cutters, E, E', one for each jaw. Each cutter is a rectangular bar of steel provided with a suitable sharpened cutting edge on each side longitudinally thereof, so that the same is rendered reversible for independent usage. In other words, either longitudinal edge of the cutter can be presented for use. Thus, if one side becomes dull or gapped the reverse side can be brought into play simply by reversing the cutter. Each cutter is detachably fitted to its seat in the inner edge of its respective jaw by the provision of the lateral mortise recess, F, at each end of the same. The adjacent end of each cutter is shaped to enter in and snugly fit into its recess, F, in the manner shown so that the cutting edge of the cutter is flush with the straight edge of the jaw to which it is secured.

The manner of rendering the cutters detachable and reversible is an important and useful feature of our invention in that it increases the life and efficiency of the cutters, and presents a more convenient and desirable arrangement as will be obvious.

G is the steel punch removably and adjustably secured to the upper jaw by the set-screw, H, and is adapted to register in operation with the die-orifice, I, formed centrally in the die-block, J, removably attached to the bracket, K, by means of a slip-joint. This slip-joint is made by providing the upper surface of the bracket, K, with an undercut recess dovetailed as shown to receive and hold the correspondingly-shaped lower end of the die-block which is insertible therein.

The rear end of the lower jaw is provided with a right-angled depending rack-bar, L, secured rigidly at its upper end to the end of the jaw and depending at right-angles vertically a prescribed distance.

M indicates a hand-lever, provided with a

circular head at its inner end in the shape of a pinion, N, intermeshing with the rack-bar. This lever is fulcrumed or pivoted by an axial pin, O, running through a central bore in the pinion and through bearing openings in the lower extremities of two parallel coextensive bearing plates, P, P', rigidly bolted at the upper ends to opposite sides of the upper jaw, respectively. Thus these two plates are separated a distance equal to the thickness of the end of the upper jaw and depend vertically parallel with each other and with the rack-bar, serving as supports for the actuating hand-lever, M. On the side opposite to the toothed face of the rack-bar is arranged a vertically rolling anti-friction-roller, Q, journaled between the inner ends of the two parallel slightly separated horizontal arms, R, R', by a pintle, S. The opposite ends of these two arms, R, R' are attached to the vertical plates, severally, by the pivot O passing through coincident holes in the adjacent ends of both.

T, T' respectively designate two parallel coextensive brace-plates severally attached at their upper ends to the upper jaw by the same bolt that secures the plates, P, P'. The lower ends of these two brace plates are secured to the horizontal arms, R, R' by the pintle, S.

From the foregoing description it will be readily apparent that by means of the lever, pinion, and rack-bar, power for operating the jaws can be applied effectively; and that by the provision of the roller, Q, friction is reduced to the minimum. Moreover, it will be manifest that the arrangement of the plates, P, P', R, R', and the brace-plates, T, T', and the roller, rack-bar and pinion serves to keep the two jaws of the device always in exact alignment.

It will be understood that in practice the

cutting edges of the upper and lower jaws overlap each other when in closed position and between the edge of each jaw and the respective bracket or punch is left a sufficient space to permit the co-operation of the knife-edges without touching the same. This is not specially shown in the drawings, but since it forms no feature of the invention and is merely a mechanical expedient it will be understood without further illustration.

Having thus fully described our invention, what we claim, and desire to secure by Letters Patent, is—

1. In a device of the class described, the combination, with the hinged cutter-jaws mutually provided with opposite coincident laterally open mortised recesses; of reversible cutters severally secured in said recesses by slip joints, and adapted for removal or insertion in a direction at right-angles to the plane of the jaws, substantially as specified.

2. In a device of the class described, the combination, with the two hinged jaws; of a rack-bar depending from the rear end of the lower stationary jaw; a triangular frame composed of supporting plates and attached loosely to, and moving with, the rear end of the upper jaw; a hand-lever carrying at its forward end a pinion meshing with the said rack-bar, and fulcrumed in the triangular frame; and an anti-friction roller journaled at the lower end of the said frame and bearing against the opposite or smooth face of the rack-bar, substantially as specified.

In testimony whereof we affix our signatures in presence of two witnesses.

GEORGE SEARS.  
WILLIAM H. UNDERWOOD.

Witnesses:

A. F. DEWITT,  
D. H. PHELPS.