



US00D516697S

(12) **United States Design Patent** (10) **Patent No.:** **US D516,697 S**  
**Stout, Jr. et al.** (45) **Date of Patent:** **\*\* Mar. 7, 2006**

(54) **DUCT END PORTION**

(75) Inventors: **William K. Stout, Jr.**, Mason, OH (US); **Ammon W. Weaver**, Liberty, KY (US)

(73) Assignee: **Eastern Sheet Metal LLC**, Cincinnati, OH (US)

(\*\*) Term: **14 Years**

(21) Appl. No.: **29/205,506**

(22) Filed: **May 14, 2004**

(51) **LOC (8) Cl.** ..... **23-04**

(52) **U.S. Cl.** ..... **D23/393**

(58) **Field of Classification Search** ..... D23/393, D23/394, 354, 262, 269, 202; 285/414-415, 285/454, 424, 363, 364; 29/890.15, 890.032  
See application file for complete search history.

(56) **References Cited**

**U.S. PATENT DOCUMENTS**

3,749,425 A	7/1973	Howland	.....	285/191
5,129,690 A	7/1992	Meinig et al.	.....	285/363
5,599,600 A	2/1997	Rau	.....	428/36.9
5,649,662 A	7/1997	Krichau et al.	.....	228/128
D383,195 S	* 9/1997	Sonden et al.	.....	D23/262
D383,196 S	* 9/1997	Sonden et al.	.....	D23/202

(Continued)

*Primary Examiner*—Catherine R. Oliver

(74) *Attorney, Agent, or Firm*—Dinsmore & Shohl LLC

(57) **CLAIM**

The ornamental design for a duct end portion, as shown and described.

**DESCRIPTION**

FIG. 1 is a top plan view of a duct end portion showing a first embodiment of our design;

FIG. 2 is a front elevational view of the duct end portion of FIG. 1, with the right side elevational view, the left side elevational view and rear elevational view being identical to FIG. 2;

FIG. 3 is an enlarged view of portions of the duct end portion taken at view 3 of FIG. 2;

FIG. 4 is a bottom plan view of FIG. 1;

FIG. 5 is a top front perspective view of FIG. 1, with the top right perspective view, the top left perspective view and the top rear perspective view being identical to FIG. 5;

FIG. 6 is an enlarged view of portions of the duct end portion taken at view 6 of FIG. 5;

FIG. 7 is a bottom front perspective view of FIG. 1, with the bottom right perspective view, the bottom left perspective view and the bottom rear perspective view being identical to FIG. 7;

FIG. 8 is an enlarged view of portions of the duct end portion taken at view 8 of FIG. 7;

FIG. 9 is a top plan view of a duct end portion showing a second embodiment of our design, with the front elevational view, the right side elevational view, the left side elevational view and the rear elevational view of the duct end portion of FIG. 9 being identical to the front elevational view of the duct end portion illustrated in FIG. 2 and the bottom plan view of the duct end portion of FIG. 9 being identical to the bottom plan view of the duct end portion illustrated in FIG. 4;

FIG. 10 is a top front perspective view of the duct end portion of FIG. 9, the top right perspective view, the top left perspective view and the top rear perspective view of the duct end portion of FIG. 9 being identical to FIG. 10;

FIG. 11 is an enlarged view of portions of the duct end portion taken at view 11 of FIG. 10;

FIG. 12 is a bottom front perspective view of the duct end portion of FIG. 9, with the bottom right perspective view, the bottom left perspective view and the lower rear perspective view of the duct end portion of FIG. 9 being identical to FIG. 12; and,

FIG. 13 is an enlarged view of portions of the duct end portion taken at view 13 of FIG. 12.

The broken lines which define the bounds of the claimed design form no part thereof.

**1 Claim, 13 Drawing Sheets**

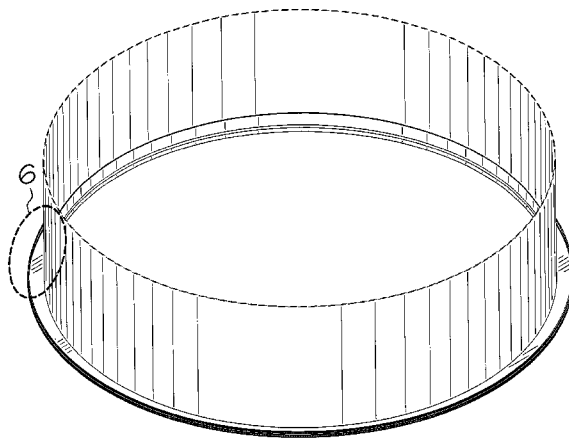

# US D516,697 S

Page 2

---

## U.S. PATENT DOCUMENTS

D386,246 S	*	11/1997	Sonden et al. ....	D23/262	D456,072 S	4/2002	Mattsson et al. ....	D23/393	
5,983,496 A		11/1999	Hermanson .....	29/890.15	D461,887 S	8/2002	Mattsson et al. ....	D23/393	
D446,298 S	*	8/2001	Thurman .....	D23/393	D466,652 S	*	12/2002	Thurman .....	D23/393
6,289,706 B1		9/2001	Hermanson .....	72/82	D475,781 S		6/2003	Mattsson et al. ....	D23/393
6,301,781 B1		10/2001	Hermanson .....	29/890.15	6,644,083 B2		11/2003	Pakker .....	72/86
D453,042 S		1/2002	Mattsson et al. ....	D23/393	6,758,502 B2	*	7/2004	Mattsson et al. ....	285/424
D454,949 S		3/2002	Mattsson et al. ....	D23/393	D504,503 S	*	4/2005	Thurman .....	D23/393
D456,071 S		4/2002	Mattsson et al. ....	D23/393	2003/0160452 A1	*	8/2003	Mattsson et al. ....	285/424

\* cited by examiner

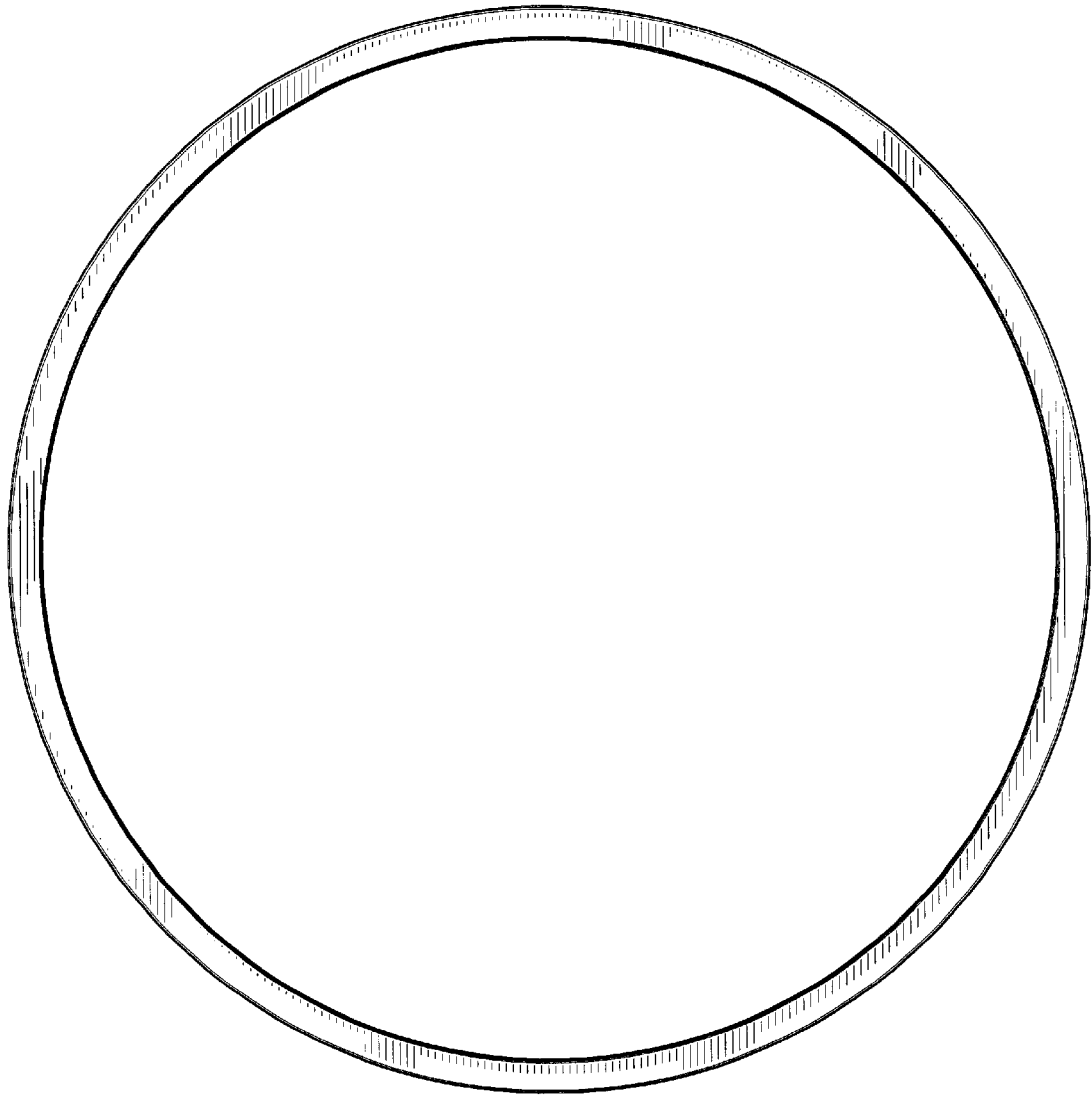
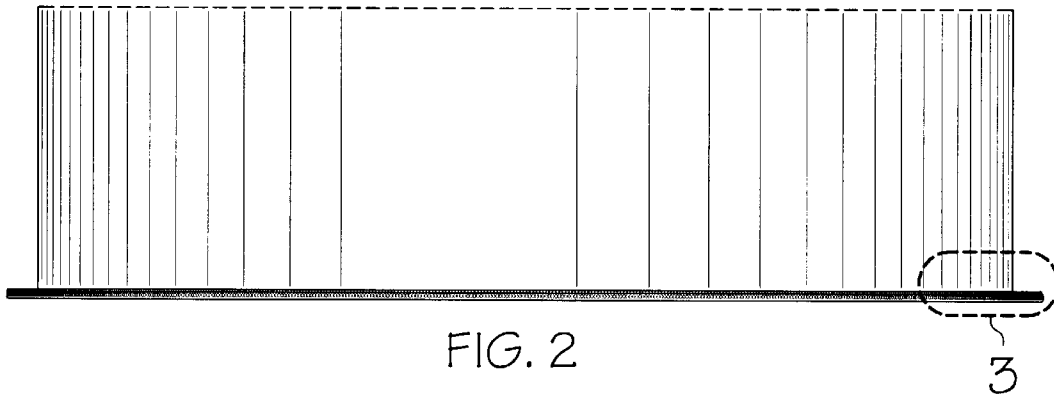

FIG. 1



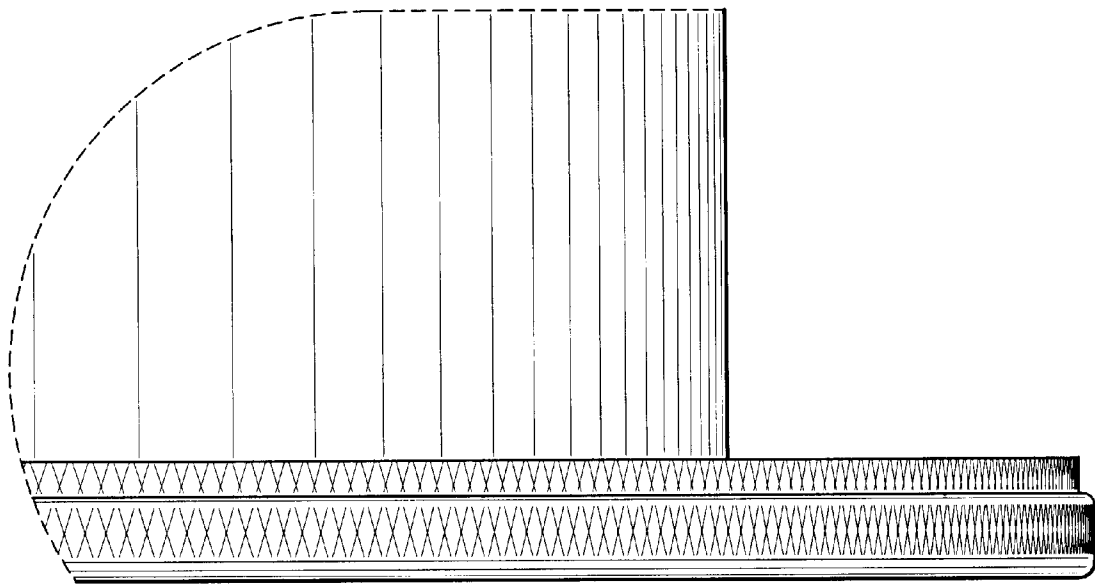

FIG. 3

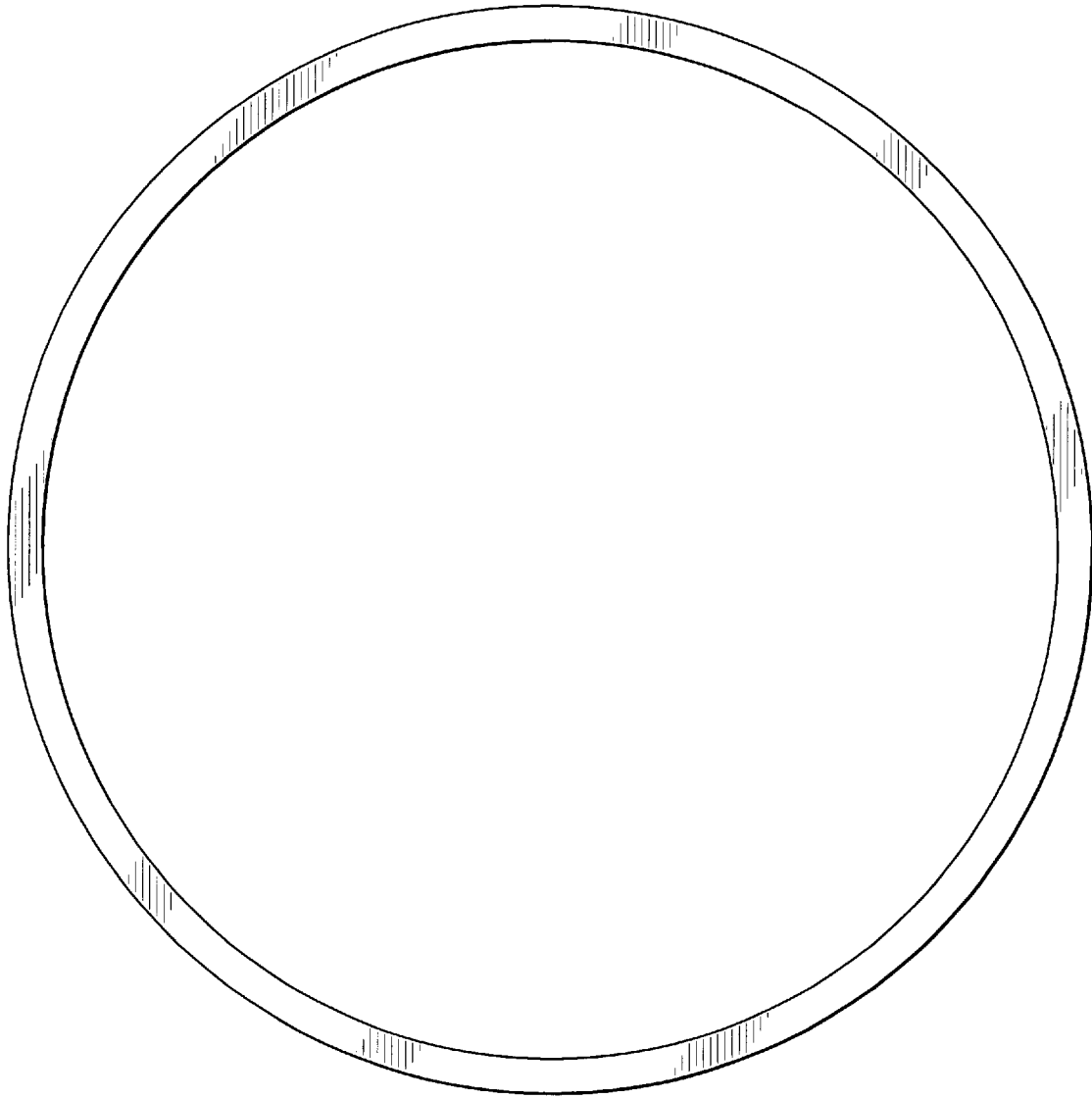

FIG. 4

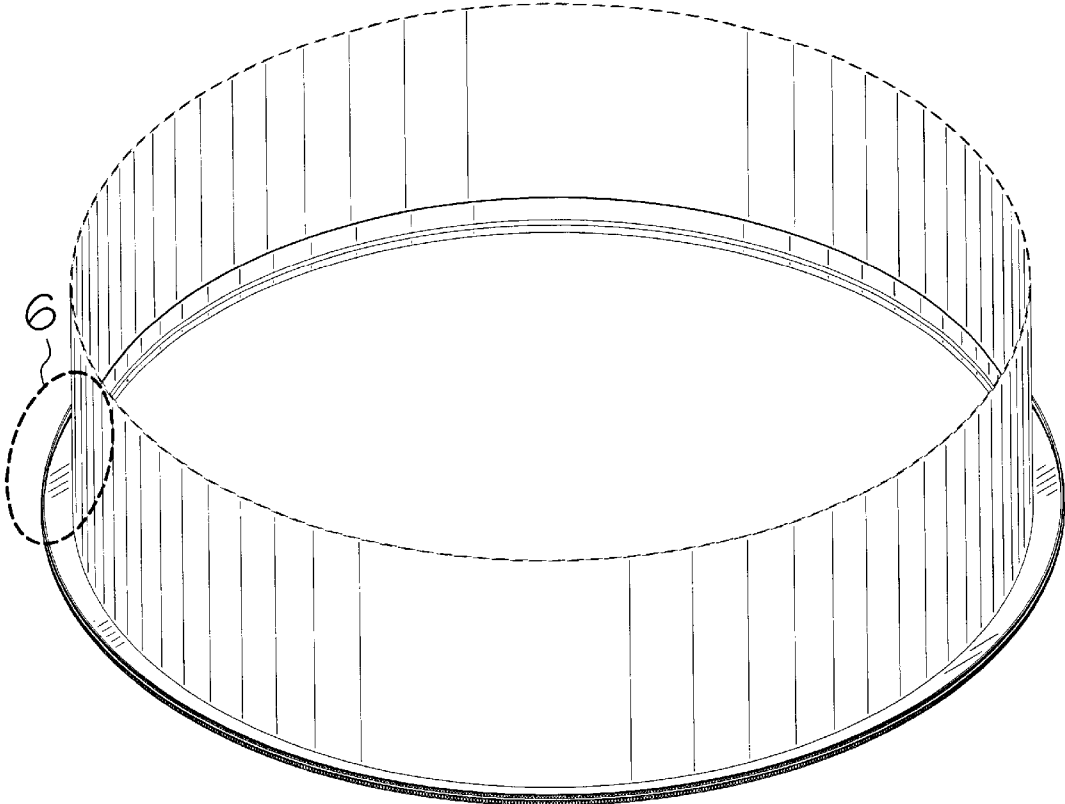

FIG. 5

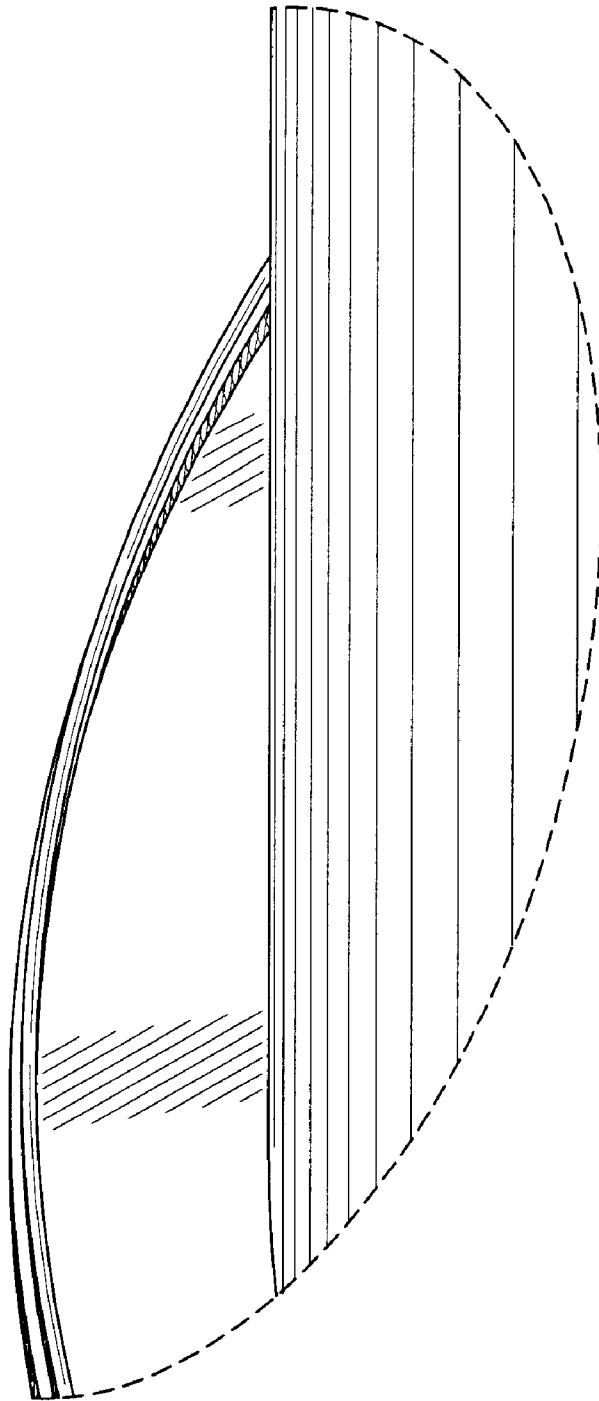

FIG. 6

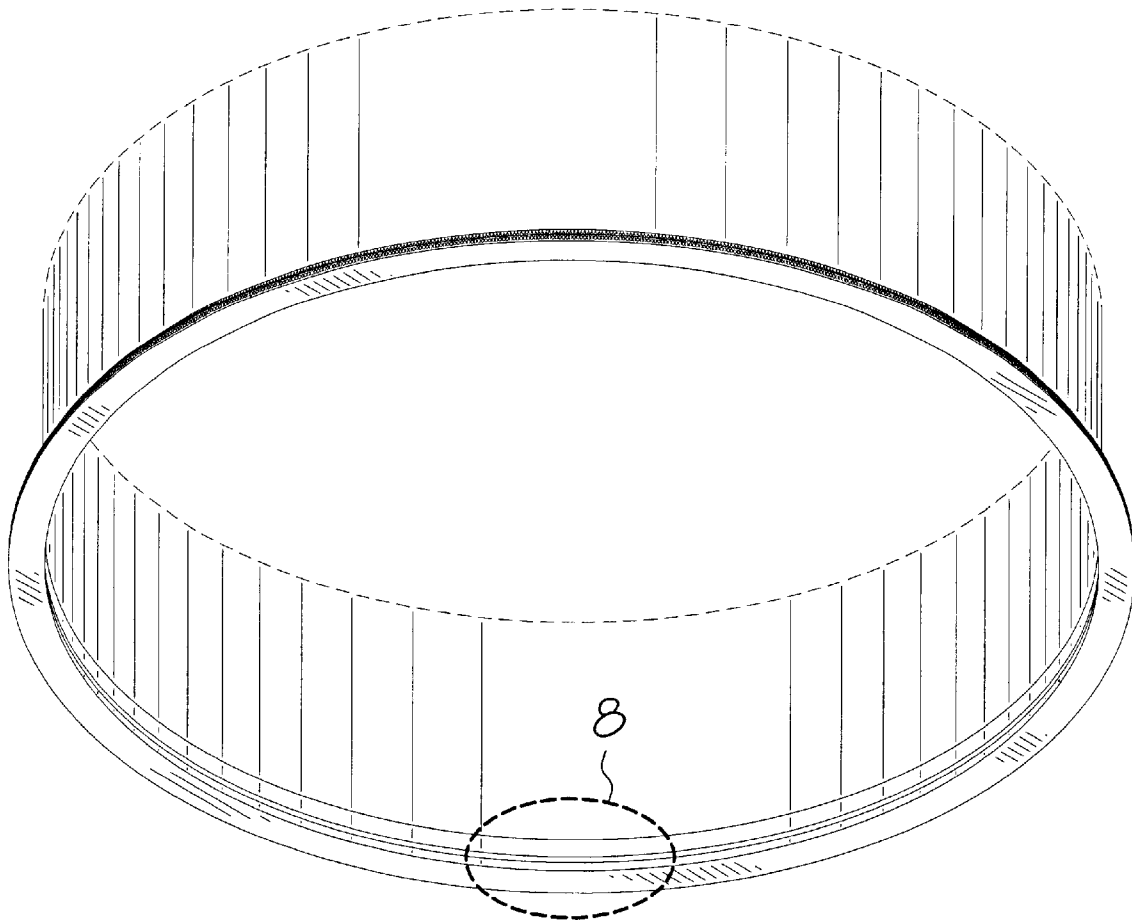

FIG. 7

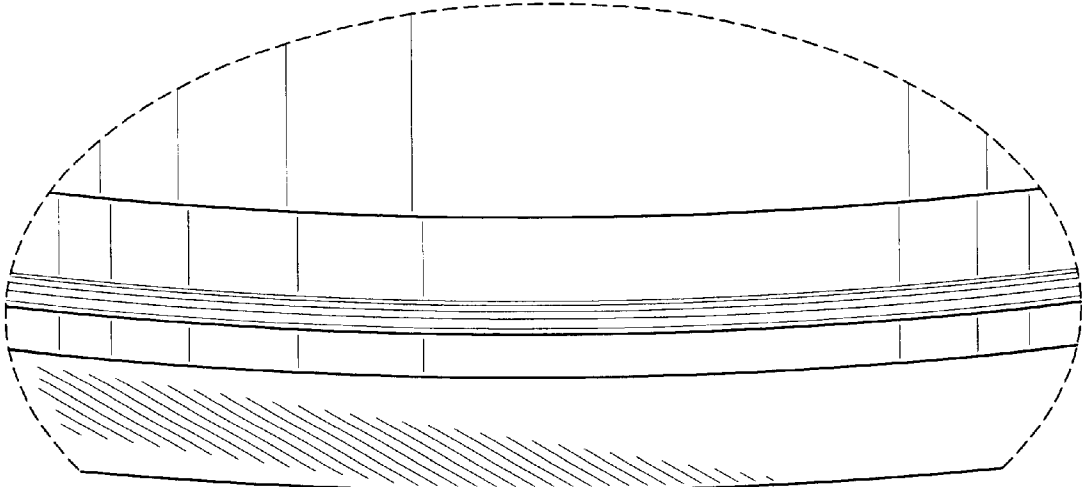

FIG. 8

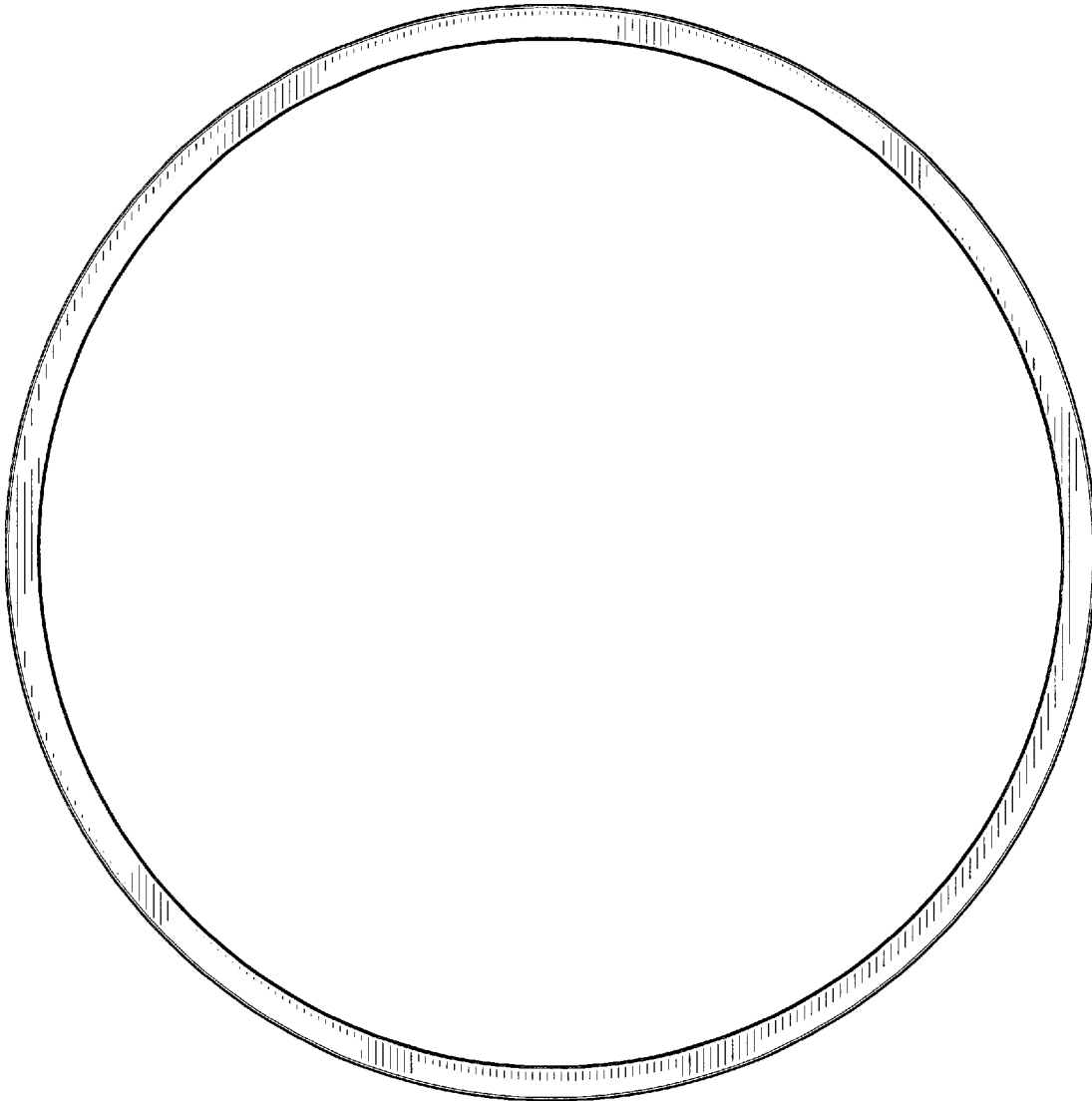

FIG. 9

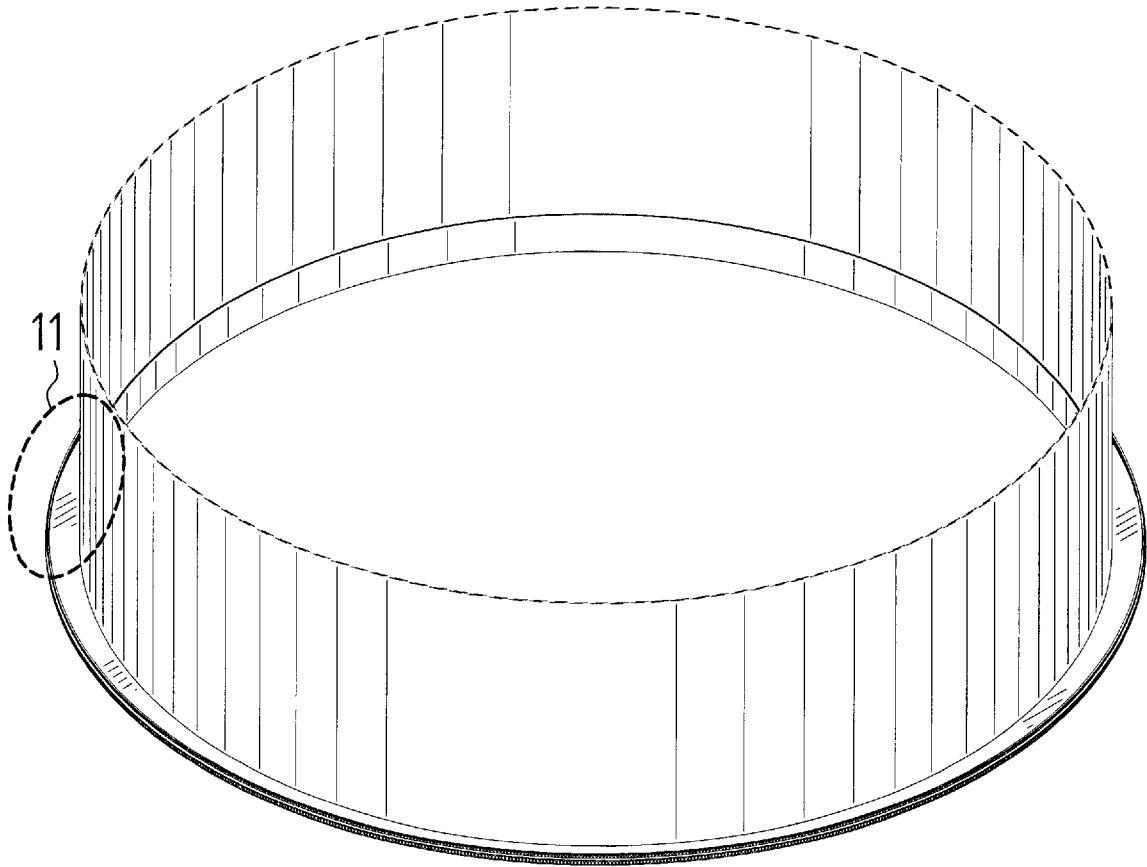

FIG. 10

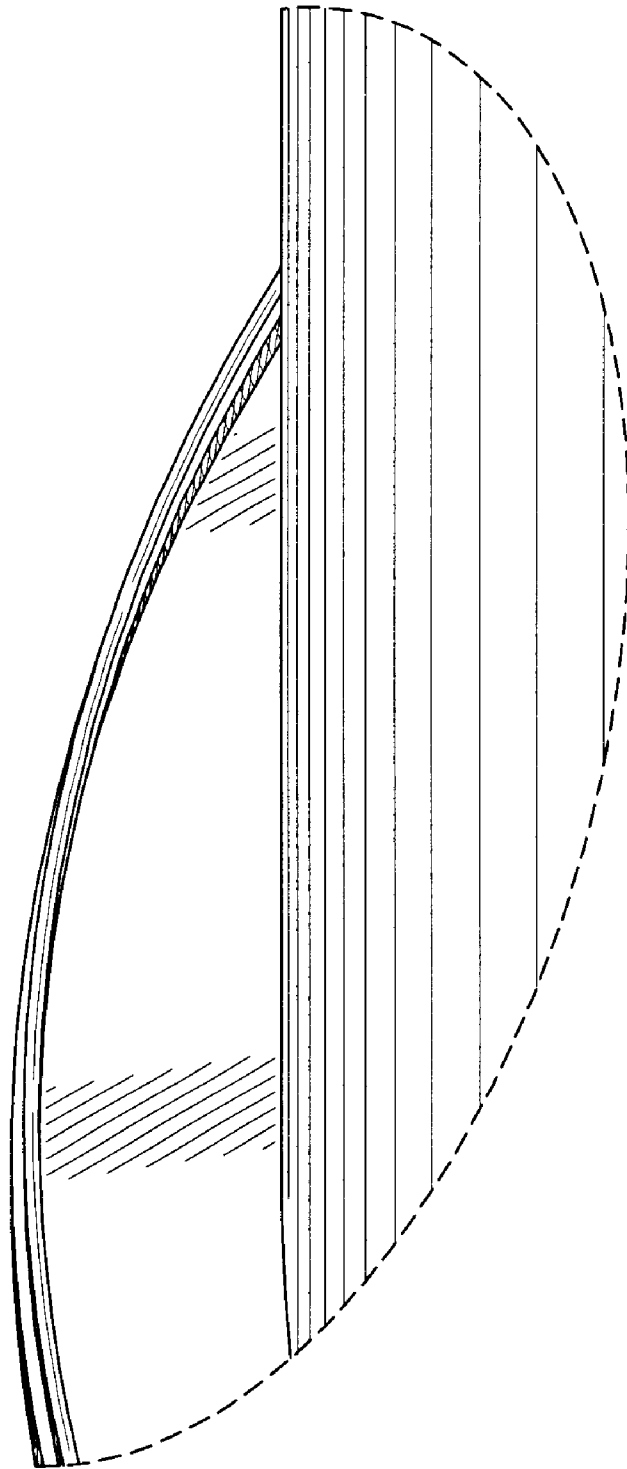

FIG. 11

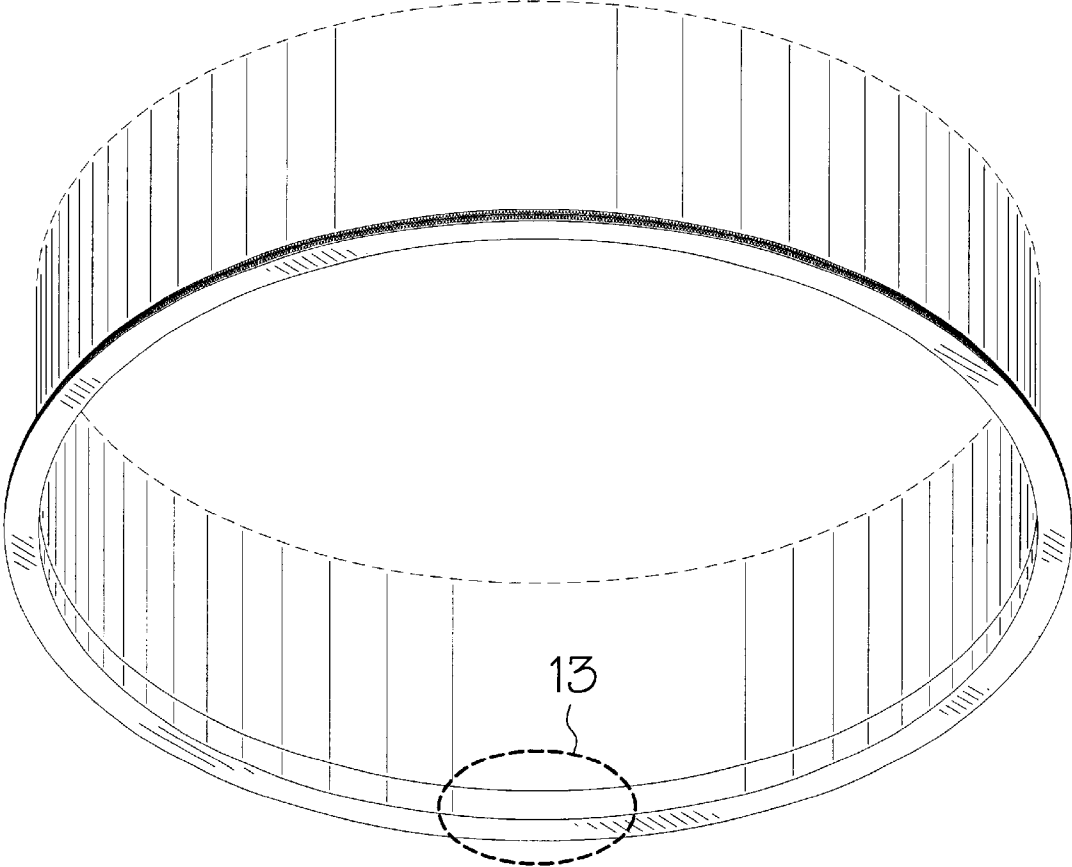

FIG. 12

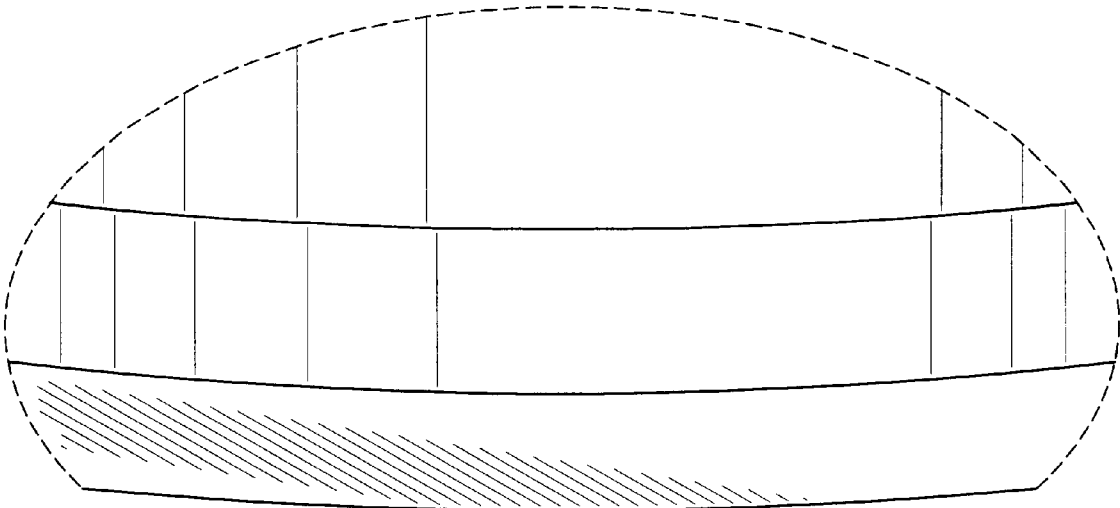

FIG. 13