



US012134044B2

(12) **United States Patent**  
**Skripps**

(10) **Patent No.:** **US 12,134,044 B2**

(45) **Date of Patent:** **\*Nov. 5, 2024**

(54) **TOY SPORTS-PLAYER FIGURE**

(71) Applicant: **OYO Toys, Inc.**, Hudson, MA (US)

(72) Inventor: **Thomas Keath Skripps**, Acton, MA (US)

(73) Assignee: **OYO Toys, Inc.**, Hudson, MA (US)

(\* ) Notice: Subject to any disclaimer, the term of this patent is extended or adjusted under 35 U.S.C. 154(b) by 0 days.

This patent is subject to a terminal disclaimer.

(21) Appl. No.: **18/182,183**

(22) Filed: **Mar. 10, 2023**

(65) **Prior Publication Data**

US 2023/0356100 A1 Nov. 9, 2023

**Related U.S. Application Data**

(63) Continuation of application No. 17/170,328, filed on Feb. 8, 2021, now Pat. No. 11,602,698, which is a continuation of application No. 14/703,127, filed on May 4, 2015, now Pat. No. 10,913,006, which is a continuation of application No. 13/253,818, filed on Oct. 5, 2011, now Pat. No. 9,022,832.

(60) Provisional application No. 61/389,839, filed on Oct. 5, 2010.

(51) **Int. Cl.**

*A63H 3/36* (2006.01)  
*A63H 3/16* (2006.01)  
*A63H 3/46* (2006.01)  
*A63H 3/48* (2006.01)

(52) **U.S. Cl.**

CPC ..... *A63H 3/36* (2013.01); *A63H 3/16* (2013.01); *A63H 3/46* (2013.01); *A63H 3/48* (2013.01)

(58) **Field of Classification Search**

CPC ... *A63H 3/16*; *A63H 3/36*; *A63H 3/46*; *A63H 3/48*; *A63H 13/00*; *A63H 11/00*  
USPC ..... 446/321, 330, 337, 340, 376, 378, 383  
See application file for complete search history.

(56) **References Cited**

U.S. PATENT DOCUMENTS

1,746,839 A 2/1930 Main et al.  
2,106,148 A 1/1938 Georg  
D160,309 S 10/1950 Fainberg et al.

(Continued)

FOREIGN PATENT DOCUMENTS

CN 3441198 4/2005  
CN 3586909 12/2006

(Continued)

OTHER PUBLICATIONS

[No Author Listed], "Bigger LEGO Figures: Taller than Four Bricks," Frog 101, 2019, retrieved from URL: <https://blog.minifigures.com/bigger-lego-figures-taller-than-four-bricks/>, retrieved on Dec. 29, 2020, 16 pages.

(Continued)

*Primary Examiner* — Joseph B Baldori

(74) *Attorney, Agent, or Firm* — Fish & Richardson P.C.

(57) **ABSTRACT**

Disclosed herein is a mini-figure that may be used with existing and standard toy block systems and also have the appearance of a sports figure. Improvements over traditional mini-figures include additional separate components in the arms and feet, an optional variation in torso shape, accessories which create visual impression of sports figures in natural use, unique markings identifiable by specific player or production, and a unique method of marketing and distribution.

**18 Claims, 42 Drawing Sheets**

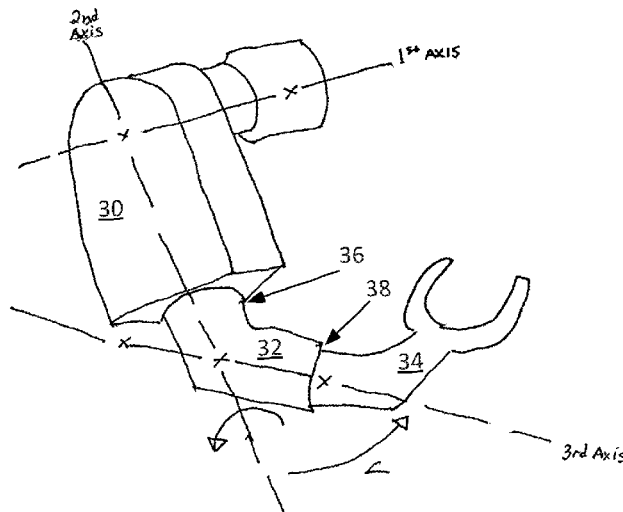



(56)

References Cited

U.S. PATENT DOCUMENTS

2015/0314211 A1 11/2015 Lama et al.  
 2015/0321109 A1 11/2015 Fukuchi et al.  
 2021/0354042 A1 11/2021 Skripps

FOREIGN PATENT DOCUMENTS

CN	301057680	11/2009
CN	303656156	4/2016
CN	303711692	6/2016
CN	303740338	7/2016
CN	303806688	8/2016
CN	304146203	5/2017
CN	304672947	6/2018
CN	304690194	6/2018
CN	304690195	6/2018
CN	304690198	6/2018
CN	304690208	6/2018
CN	304690209	6/2018
CN	304822190	9/2018
CN	304822191	9/2018
CN	305054682	3/2019
CN	305460255	11/2019
CN	305460257	11/2019
CN	305612054	2/2020
EP	006381562-0002	4/2019
EP	006381562-0001	5/2019
HK	0800191	1/2008

OTHER PUBLICATIONS

[No Author Listed], "Crazy Arms—Javelin Set," CrazyBricks.com, 2016, retrieved from URL: <http://crazybricks.bigcartel.com/product/crazy-arms-javelin-set>, retrieved on Dec. 12, 2020, 4 pages.  
 Thita, "OYO Sports & how it compares to LEGO?," TheBrickBlogger.com, retrieved from URL: <http://thebrickblogger.com/2015/02/oyo-sports-how-it-compares-to-lego/>, retrieved on Dec. 29, 2020, 9 pages.  
 US Copyright Registration No. VA655-104, "Basic Minifigures," LEGO Futura Aps, effective Jan. 21, 1994, retrieved on Jan. 6, 2021, 7 pages.  
 US Copyright Registration No. VA655-230, "Figure with Brown Hair," LEGO Futura Aps, effective Jan. 21, 1994, retrieved on Jan. 6, 2021, 8 pages.  
 US Trademark Serial No. 2,273,314, registered Aug. 31, 1999, retrieved on Jan. 6, 2021, 2 pages.  
 US Trademark Serial No. 2,273,321, registered Aug. 31, 1999, retrieved on Jan. 6, 2021, 2 pages.  
 US Trademark Serial No. 2,922,658, registered Feb. 1, 2005, retrieved on Jan. 6, 2021, 1 page.  
 US Trademark Serial No. 4,903,968, registered Feb. 23, 2016, retrieved on Jan. 6, 2021, 2 pages.  
 Amazon.com [online], "Lego Series 10 Baseball Fielder Mini Figure," Apr. 23, 2016, retrieved on Mar. 6, 2023, retrieved from URL <<https://www.amazon.com/dp/B00001LAJA/>>, 7 pages.  
 Amazon.com [online], "Lego: Minifigures Series 3 > Baseball Player Mini Figure," Feb. 14, 2011, retrieved on Mar. 6, 2023, retrieved from URL <<https://www.amazon.com/dp/B004FTKABQ/>>, 6 pages.

\* cited by examiner

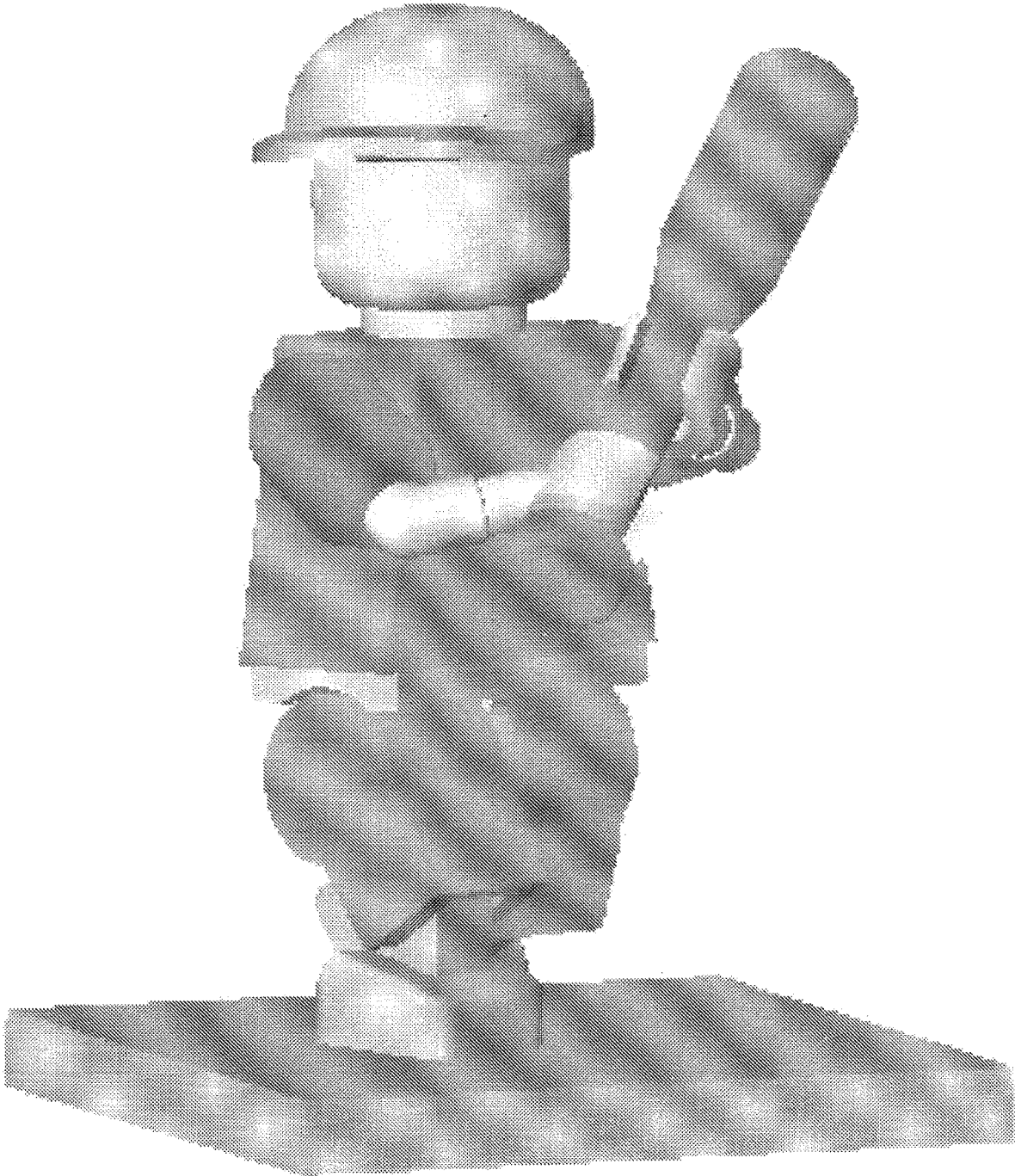

FIG. 1

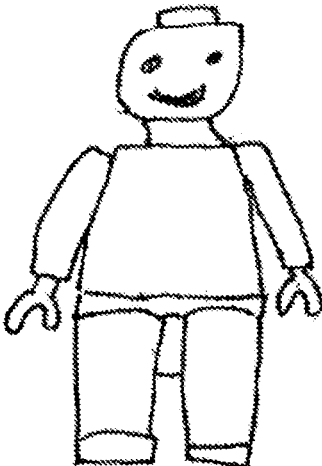

FIG. 2A

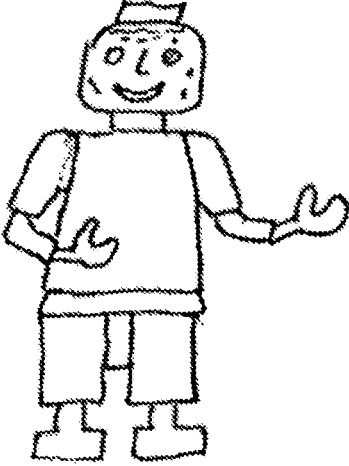

FIG. 2B

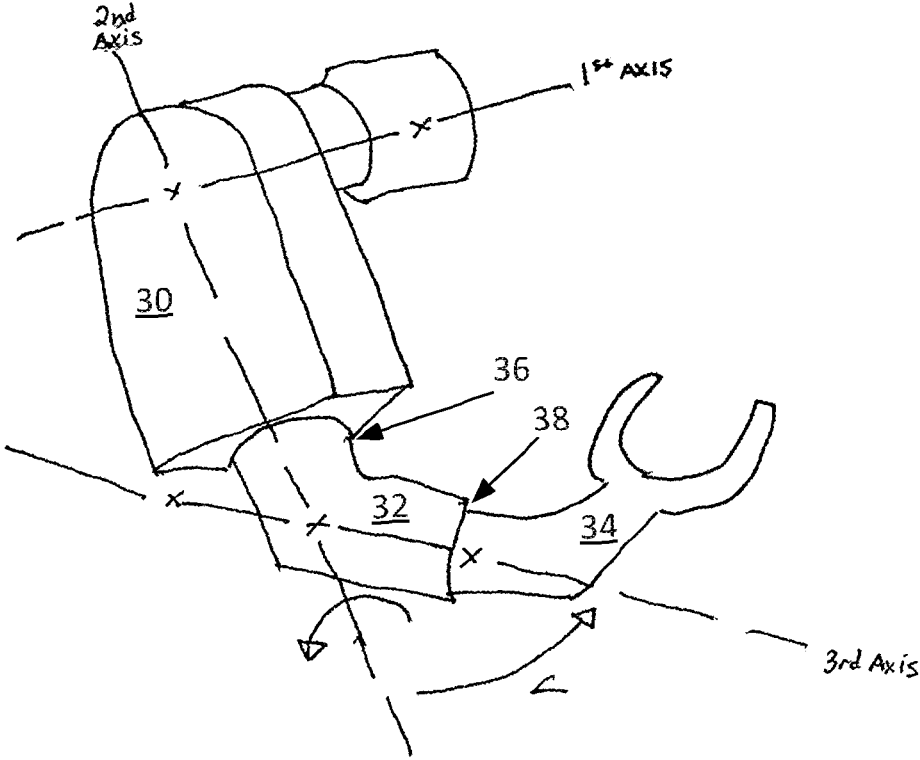

FIG. 3



Dustin  
Pedroia



Victor  
Martiez



Kevin  
Youkilis



John  
Lackey



Clay  
Buchhold



Time  
Wakefield

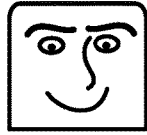

Adrian  
Beltre



Jason  
Varitek



Josh  
Beckett



J.D.  
Drew



David  
Ortiz



Jacoby  
Ellsbury



Jon  
Lester



Daisuke  
Matsuzaka



Daniel  
Bard

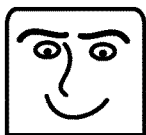

Marco  
Scutaro



Jonathan  
Papelbon

FIG. 4

Fig. 5

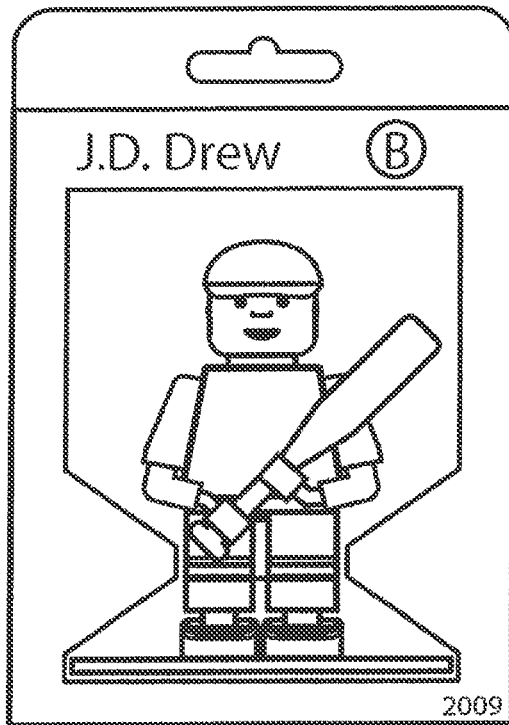

Fig. 6

PLAYER STATS										
YEAR	AB	AVG	BB	H	HR	3B	2B	1B	R	E
2007	50	0.5	5	25	1	2	2	20	9	2
2008	50	0.5	5	25	1	2	2	20	9	2
2009	50	0.5	5	25	1	2	2	20	9	2
2010	50	0.5	5	25	1	2	2	20	9	2

PLAYER BIO

J.D. DREW 2009  
BOSTON RED SOX

Fig. 7

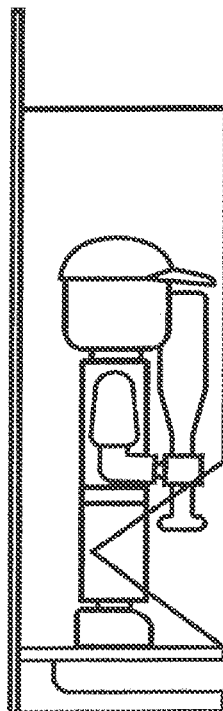

FIG. 8A

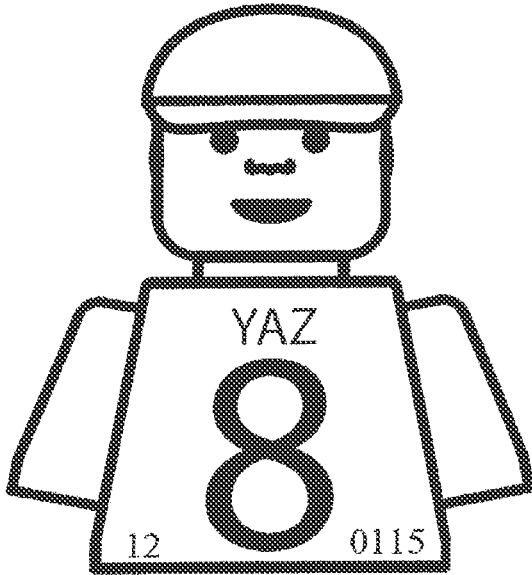

FIG. 8B

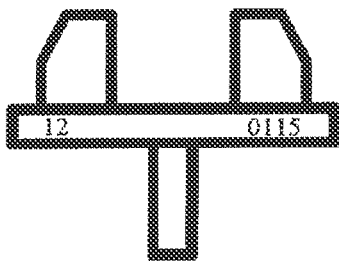
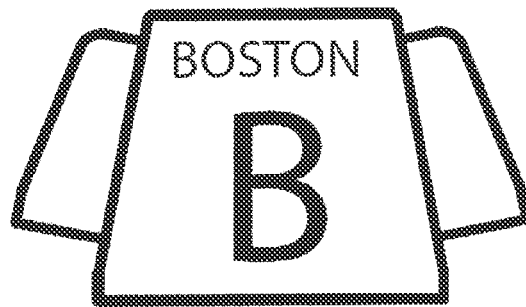
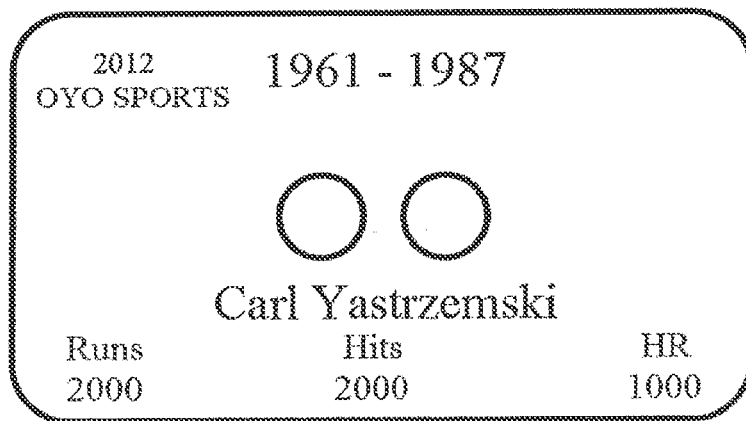

Fig. 9



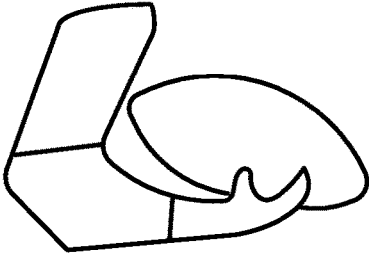

FIG. 10

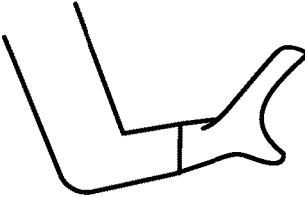

FIG. 11

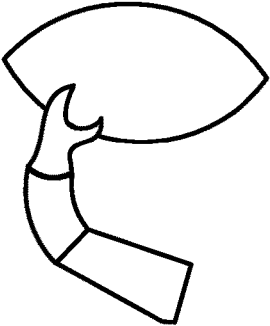

FIG. 12

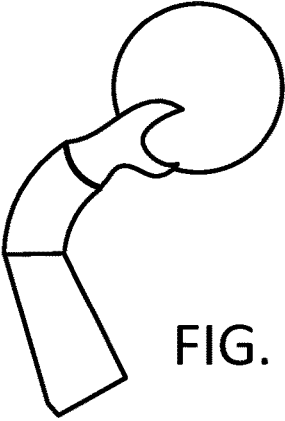

FIG. 13

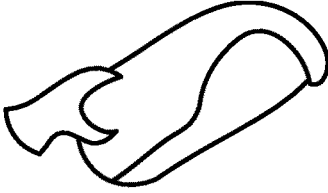

FIG. 14

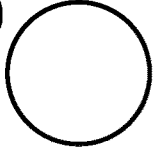
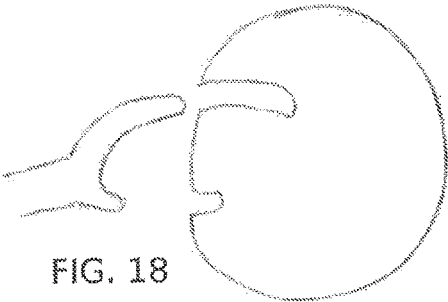
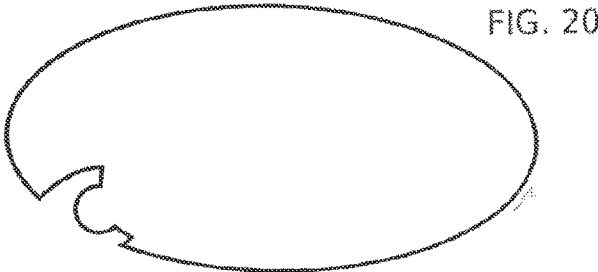
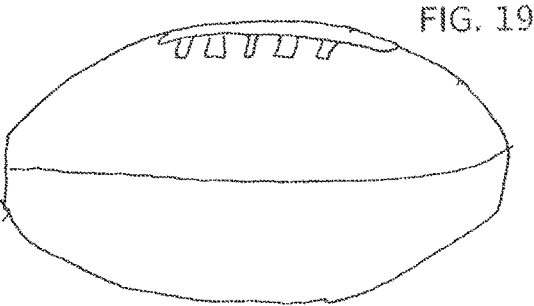
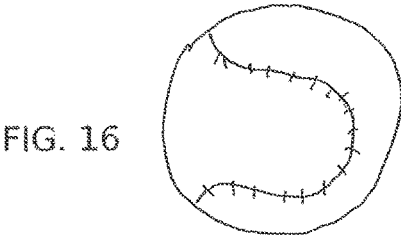

FIG. 15



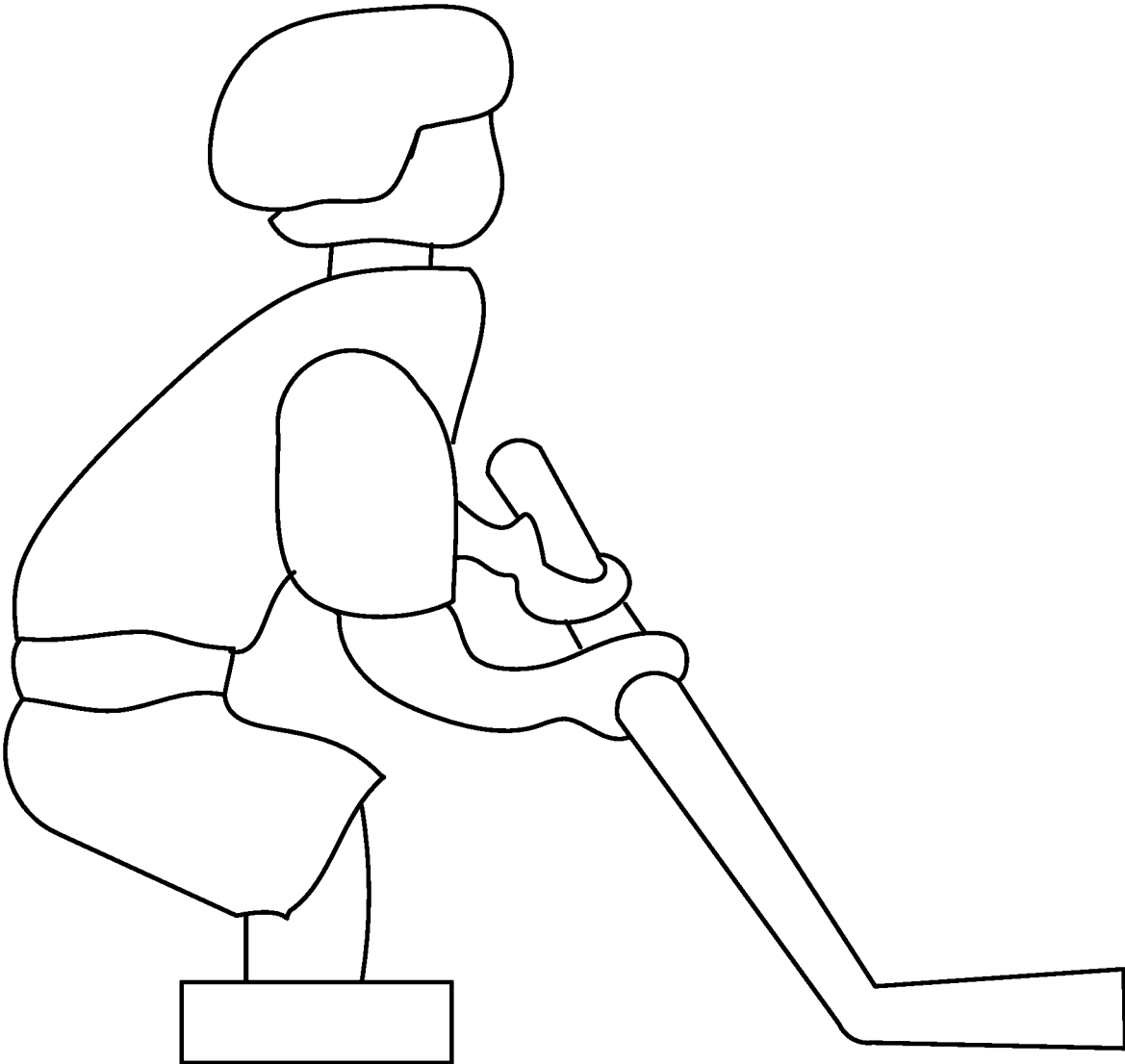

FIG. 21

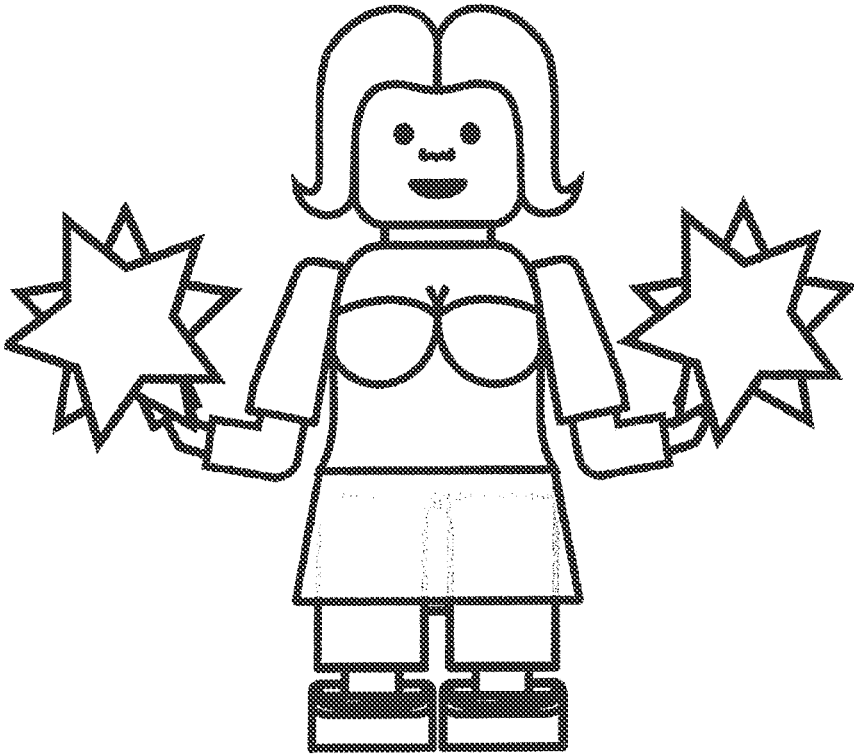

FIG. 22

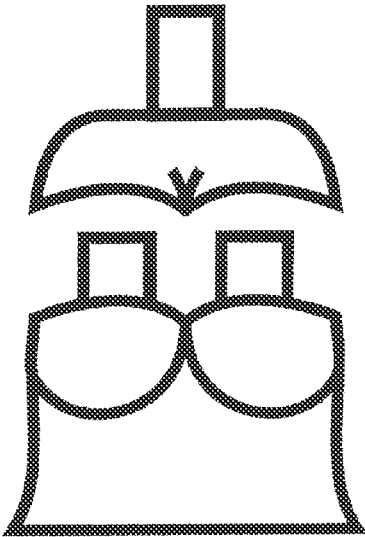

FIG. 23

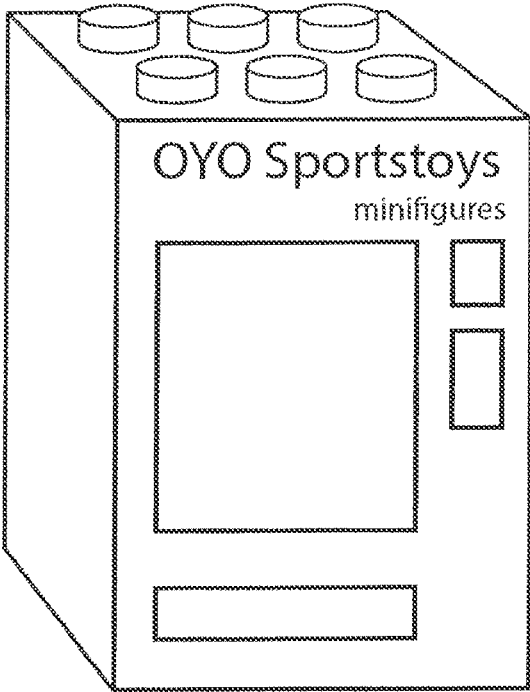

FIG. 24A

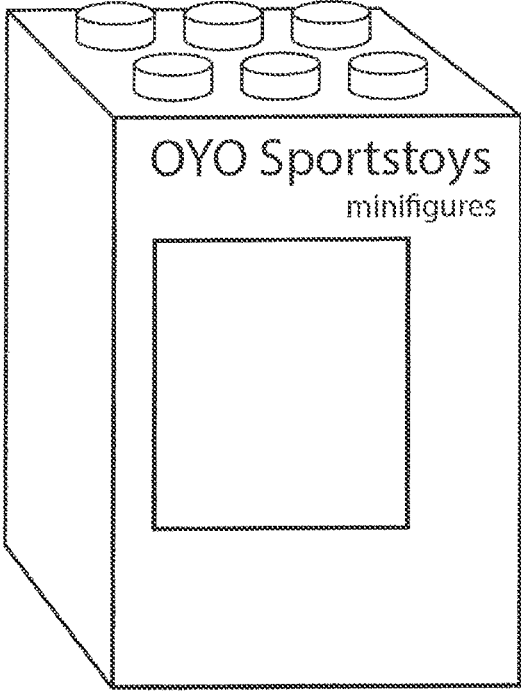

FIG. 24B

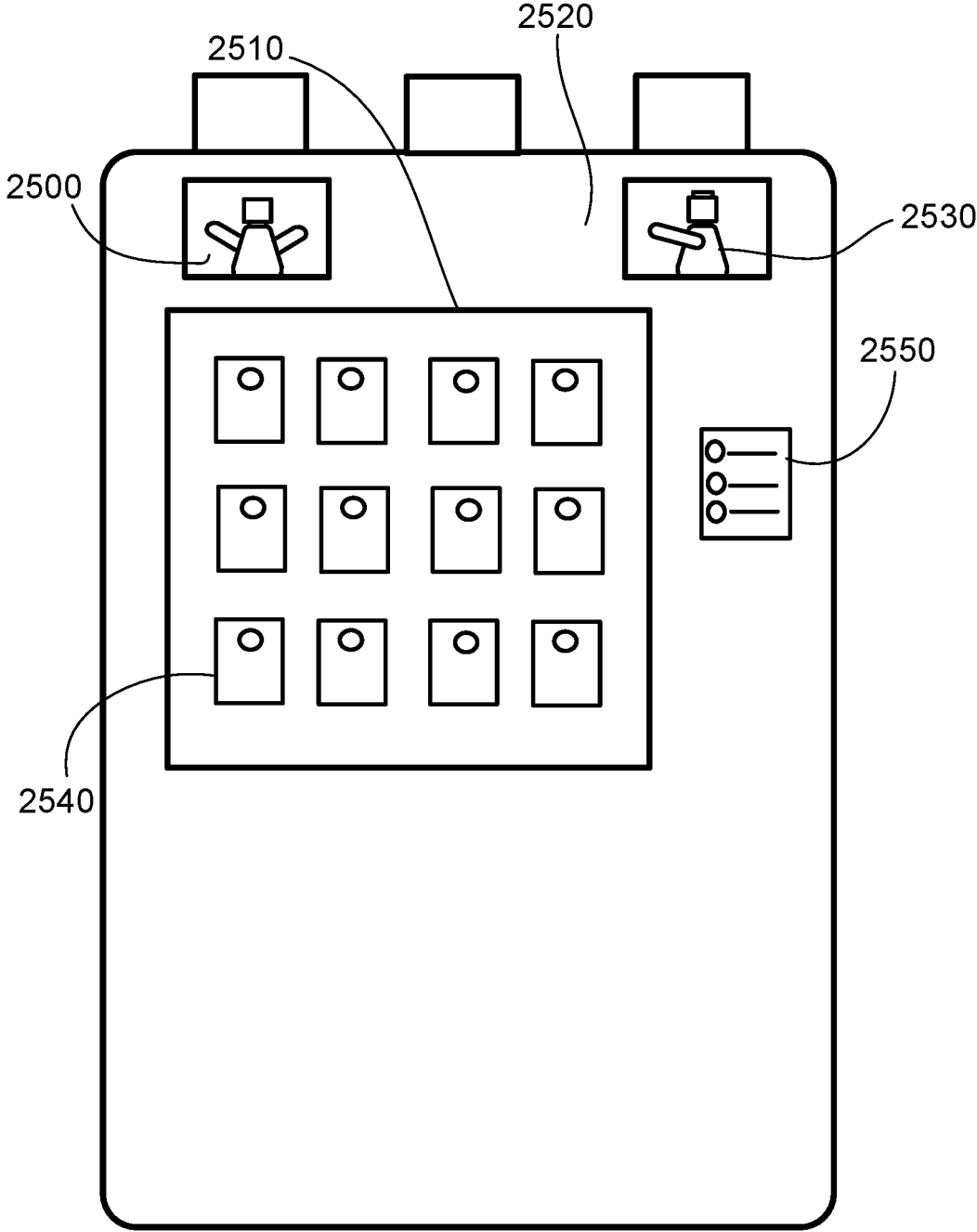

FIG. 25

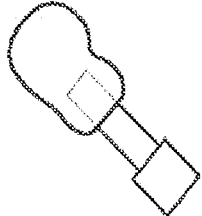
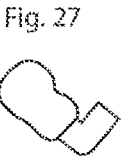
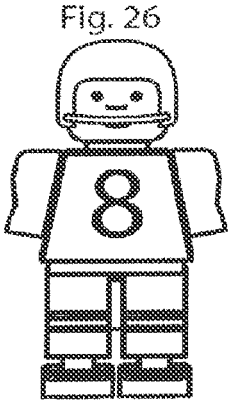

FIG. 30

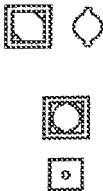
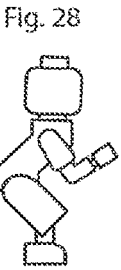

FIG. 31

FIG. 32

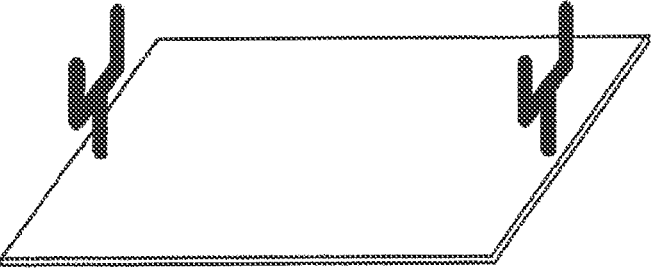

FIG. 33

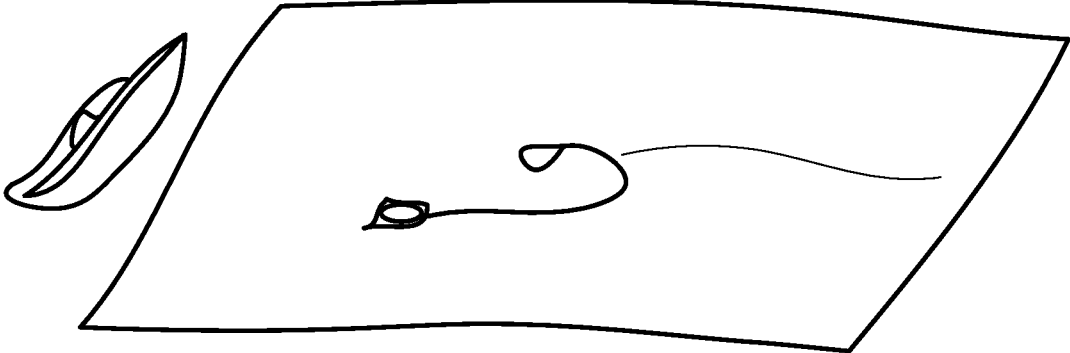

FIG. 34

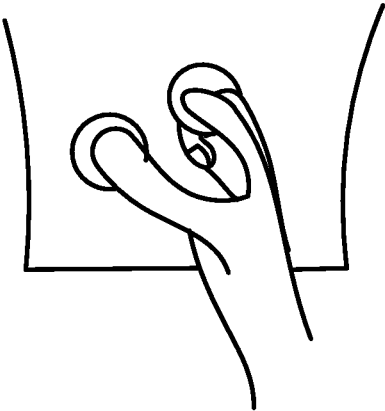

FIG. 35A



FIG. 35B

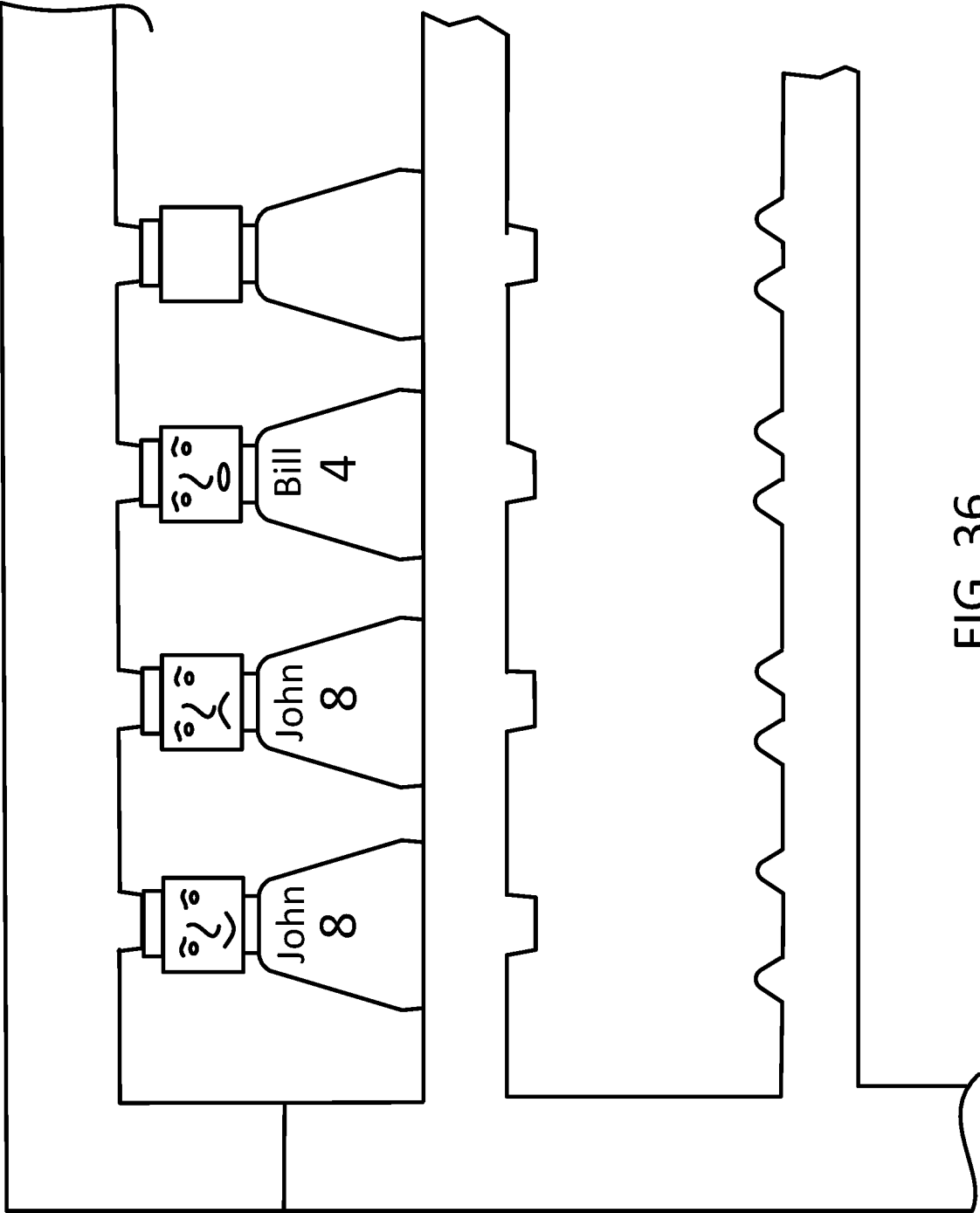

FIG. 36

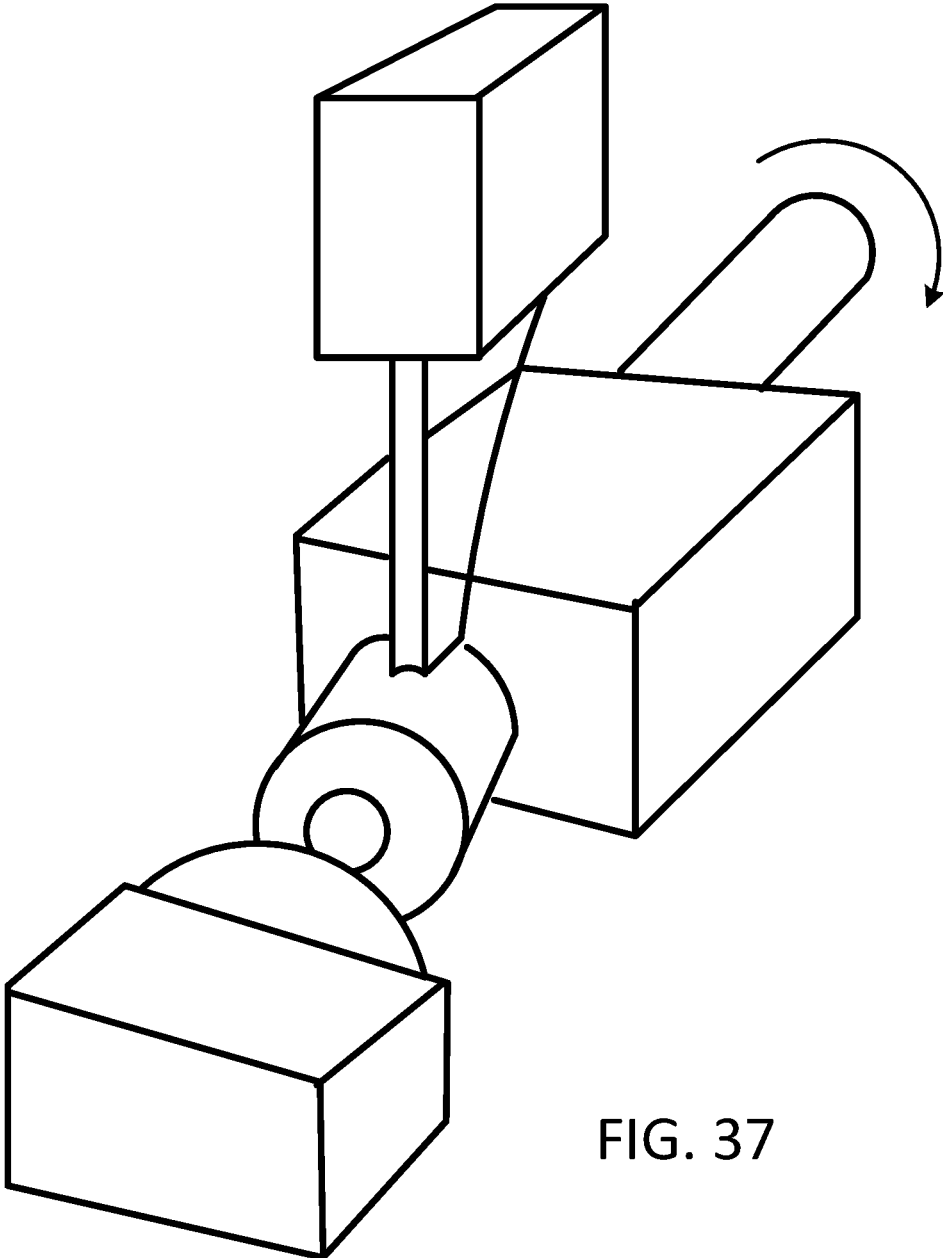
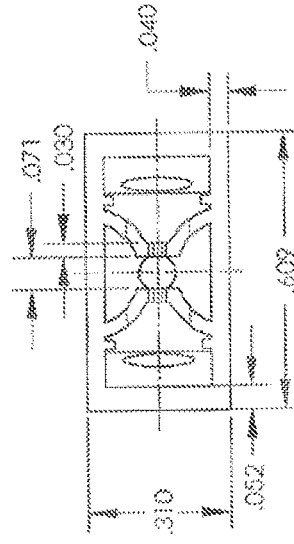
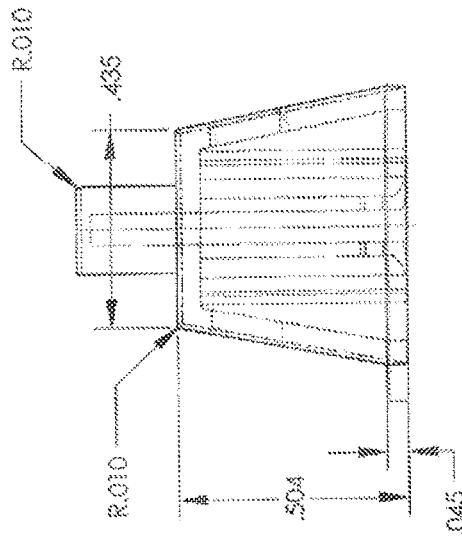
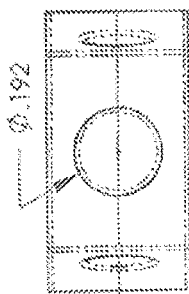
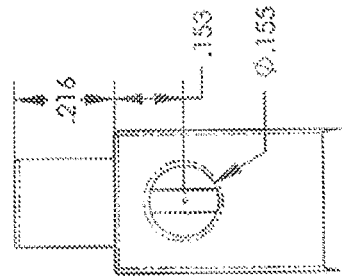
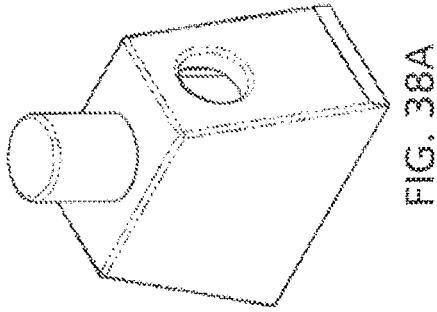

FIG. 37



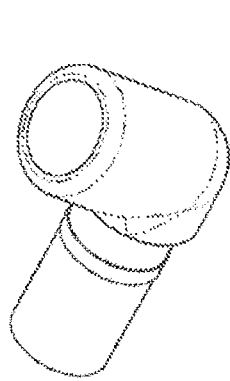

FIG. 39A

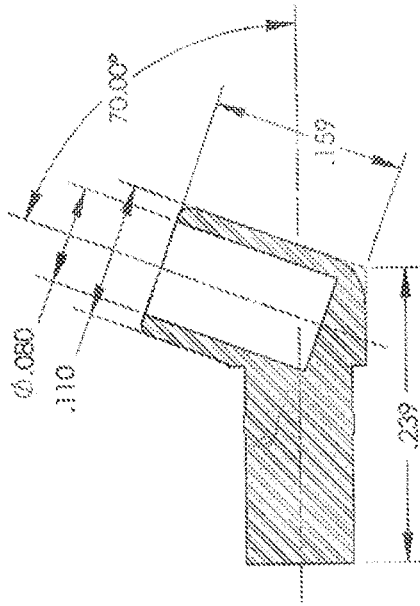

FIG. 39E

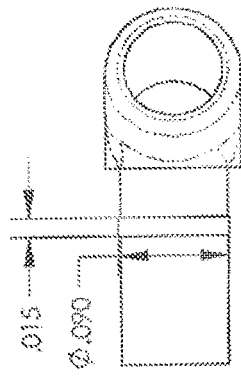

FIG. 39B

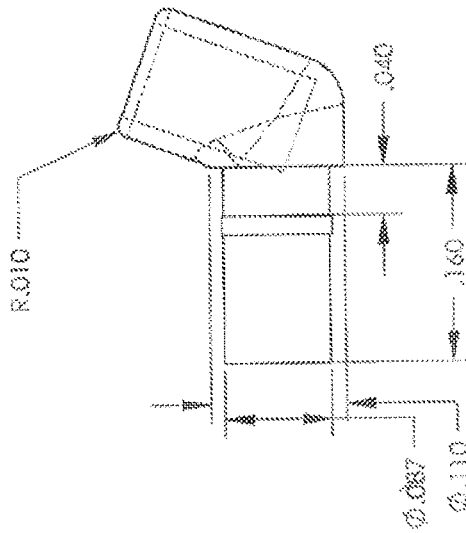

FIG. 39D

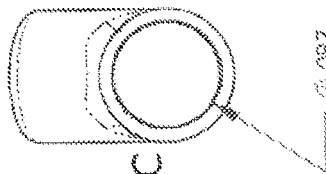

FIG. 39C

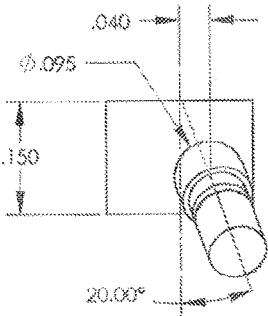

FIG. 40B

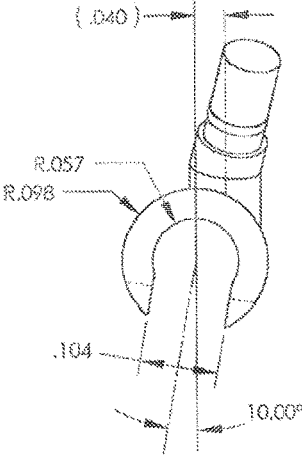

FIG. 40C

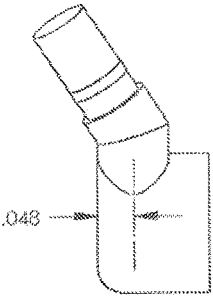

FIG. 40D

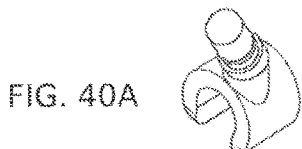

FIG. 40A

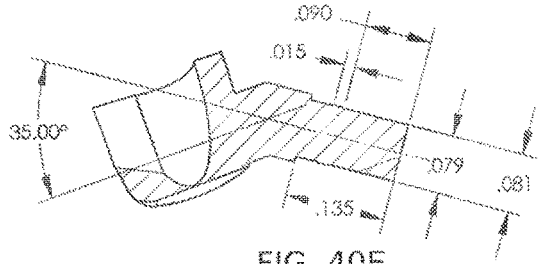

FIG. 40E

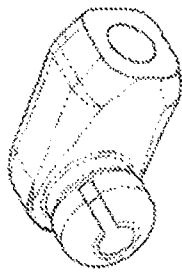

FIG. 41A

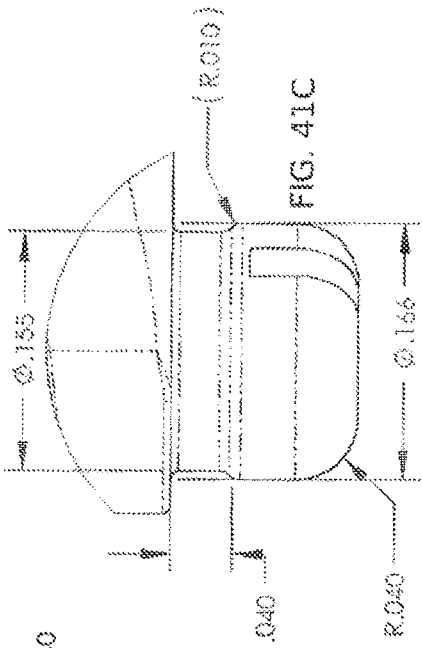

FIG. 41C

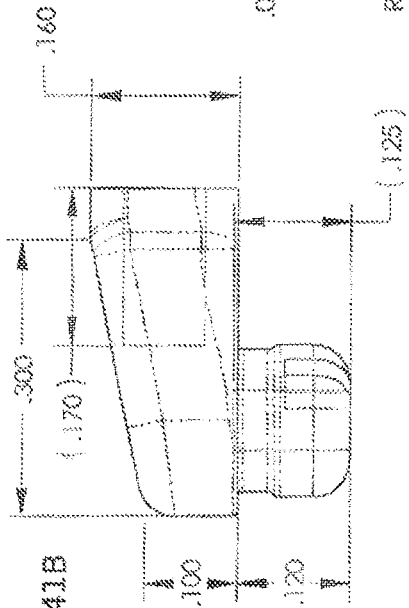

FIG. 41B

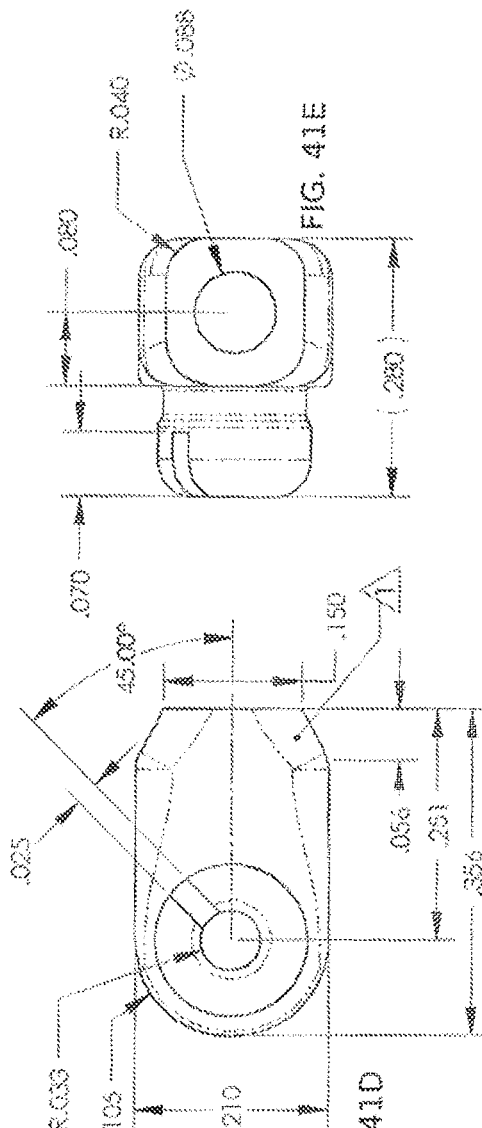

FIG. 41D

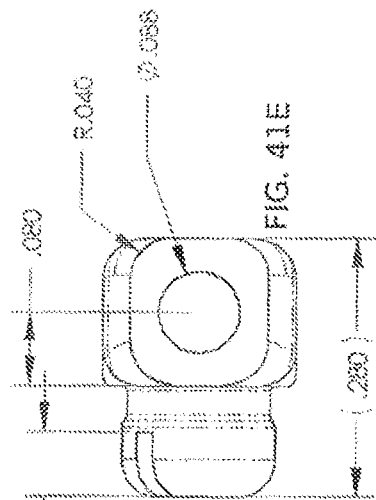
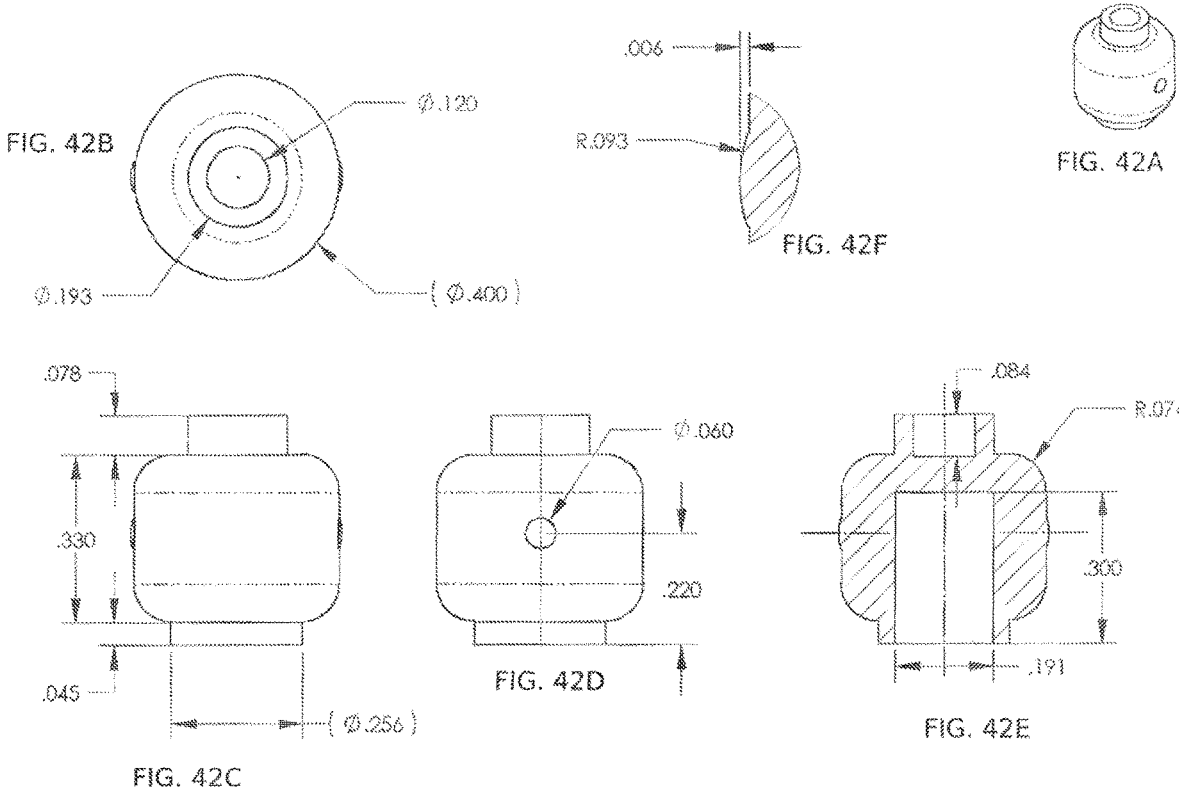

FIG. 41E

▲ VARIABLE RADIUS: TRANSITION FROM  
R.040 TO .005 TO .040



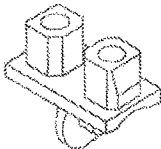
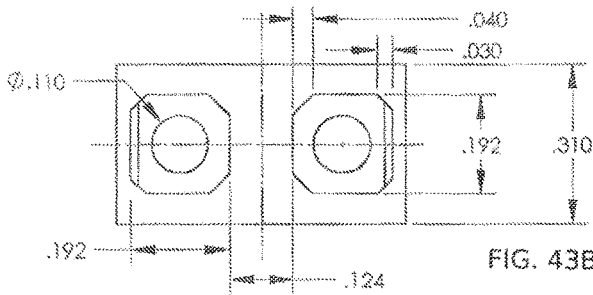

FIG. 43A

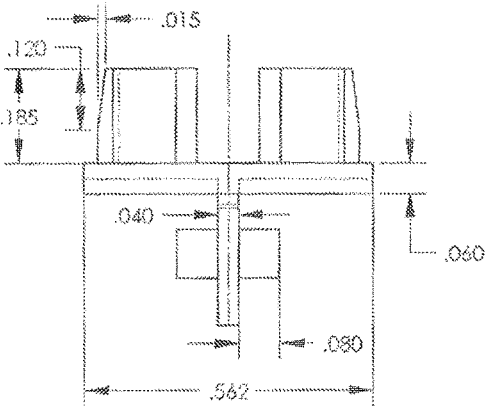

FIG. 43C

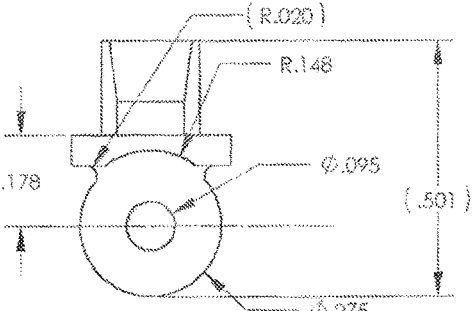

FIG. 43D

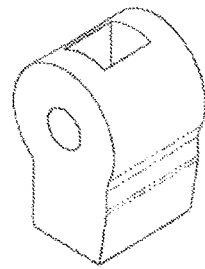
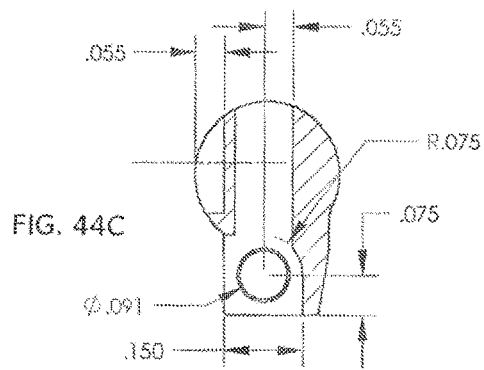
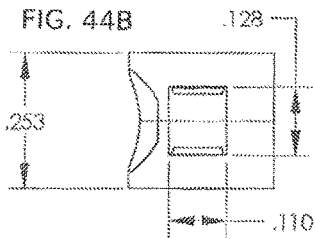

FIG. 44A

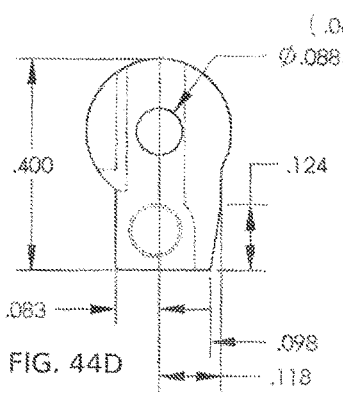

FIG. 44D

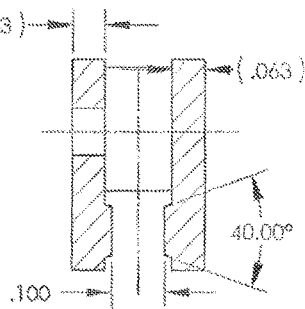

FIG. 44E

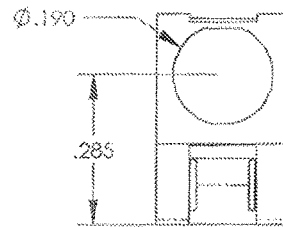

FIG. 44F

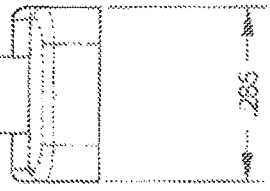
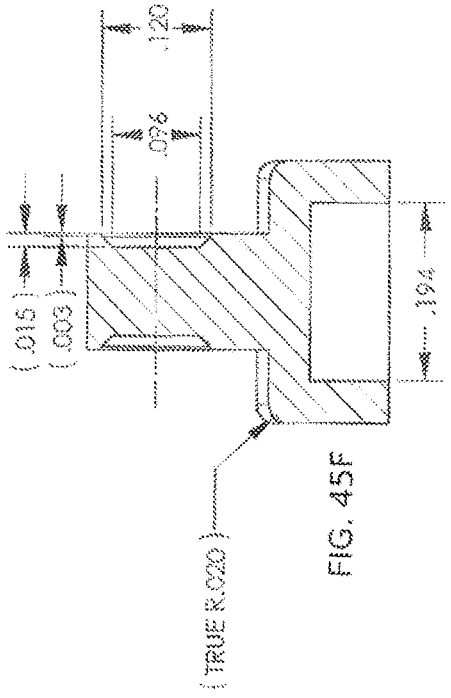
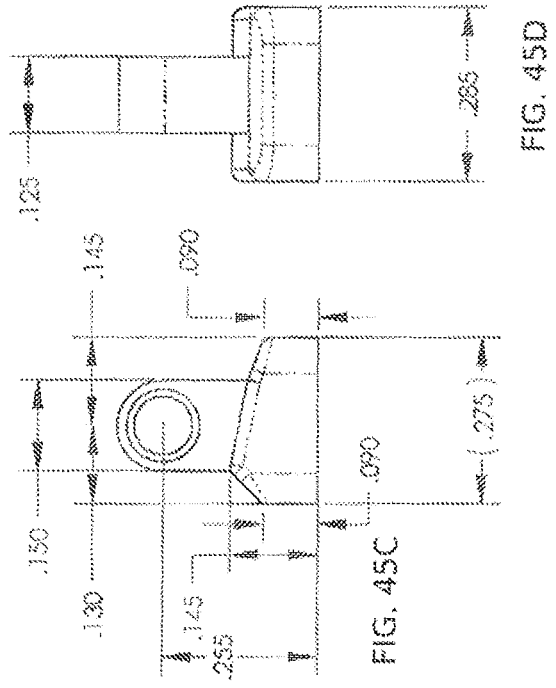
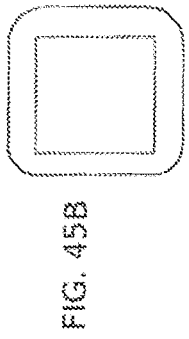
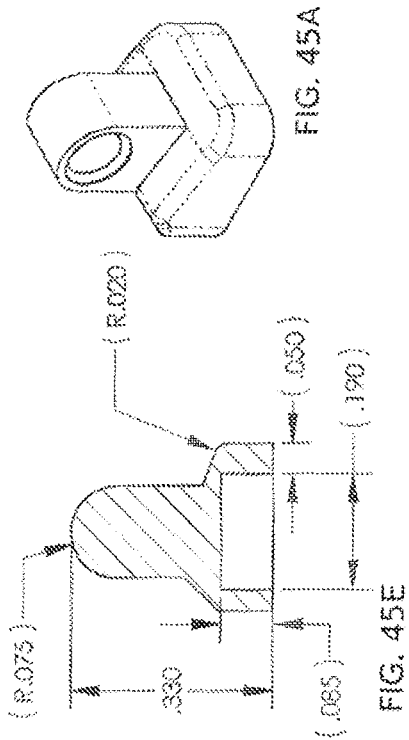

FIG. 45F

FIG. 45D

FIG. 45E

FIG. 45B

FIG. 45A

FIG. 45C

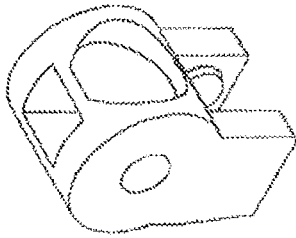

FIG. 46A

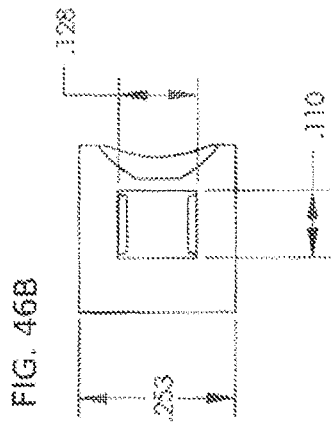

FIG. 46B

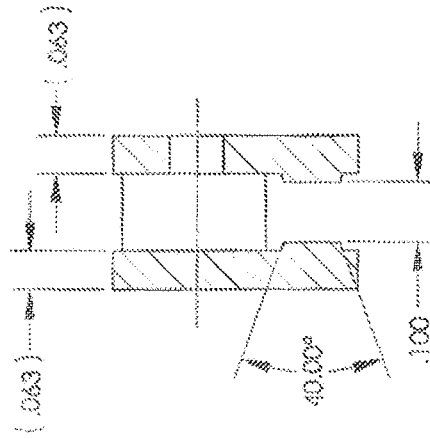

FIG. 46D

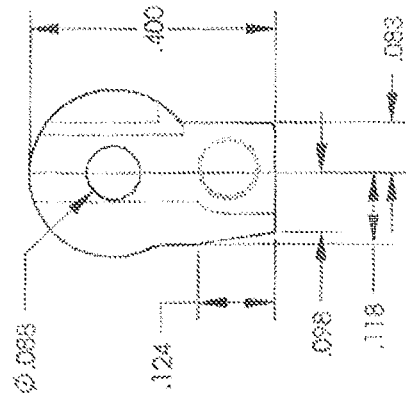

FIG. 46C

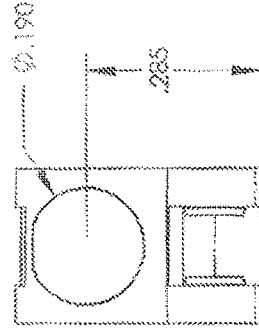

FIG. 46E

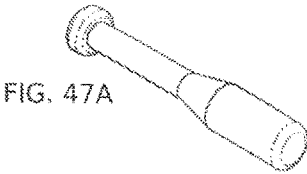

FIG. 47B

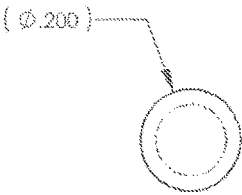
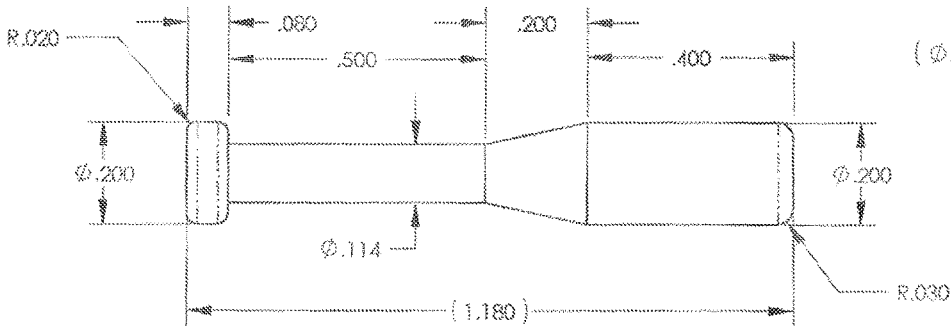
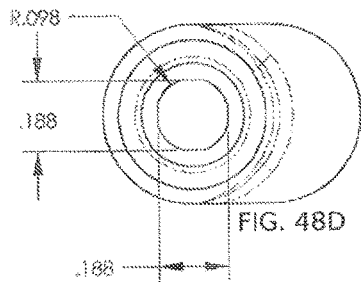
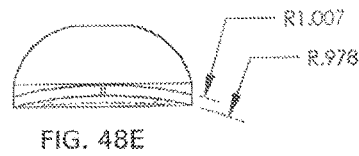
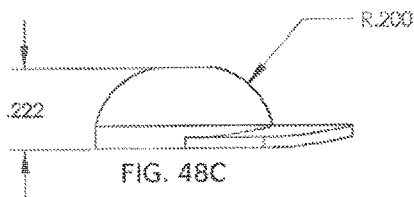
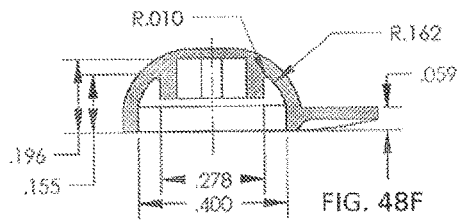
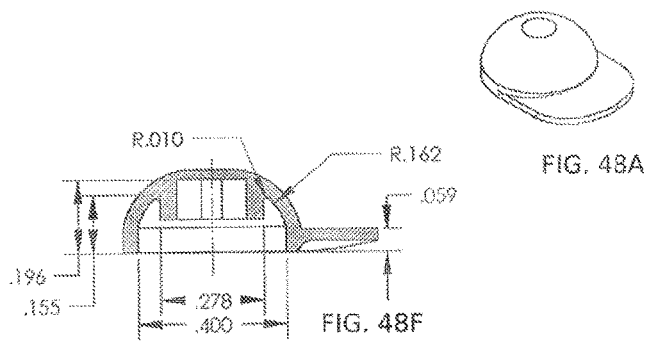
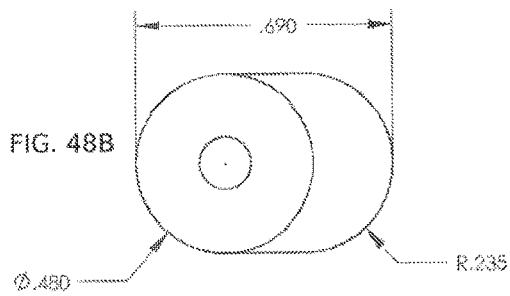

FIG. 47C



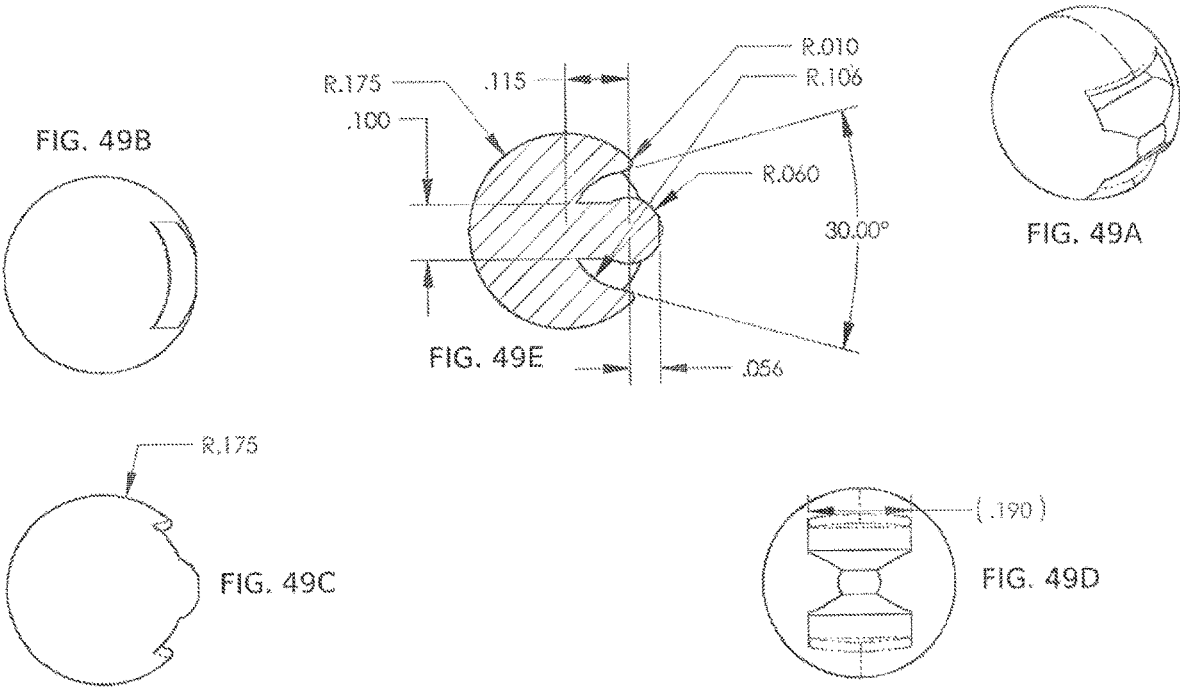



FIG. 50A

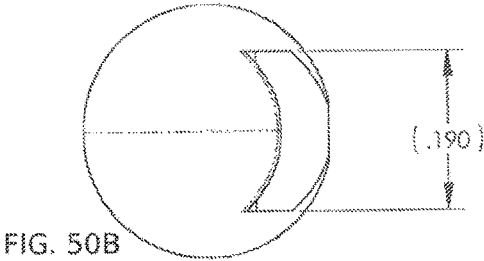

FIG. 50B

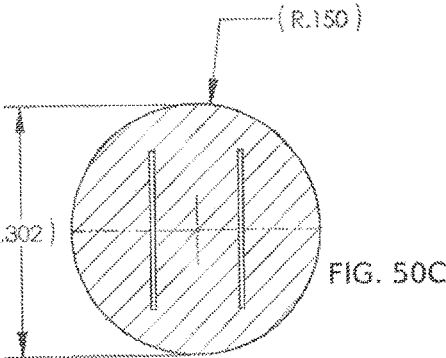

FIG. 50C

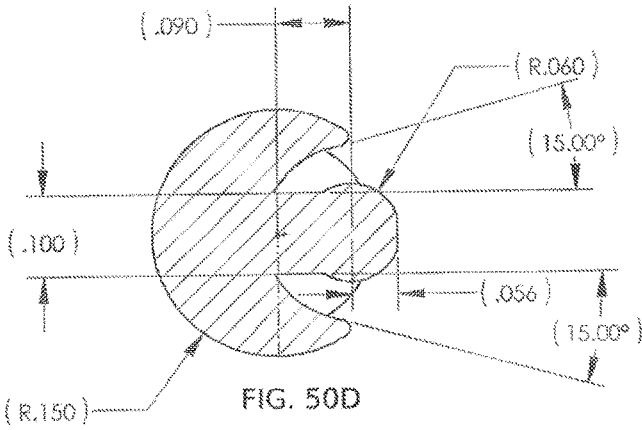

FIG. 50D

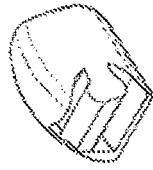
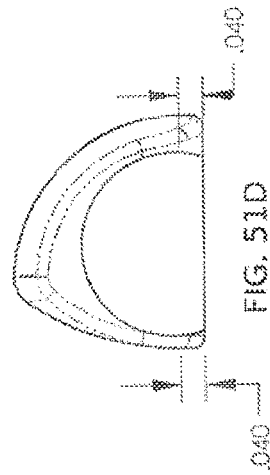
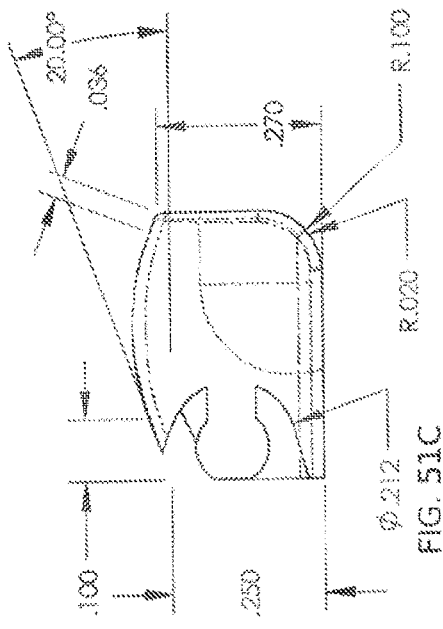
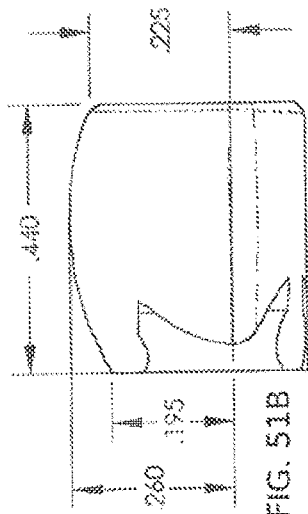
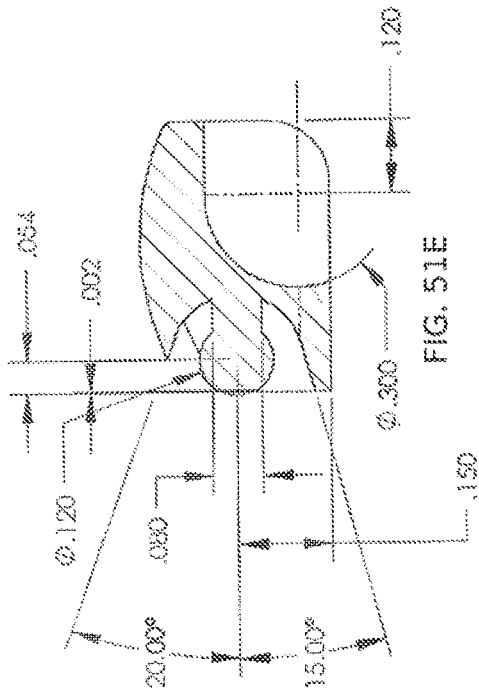

FIG. 51A



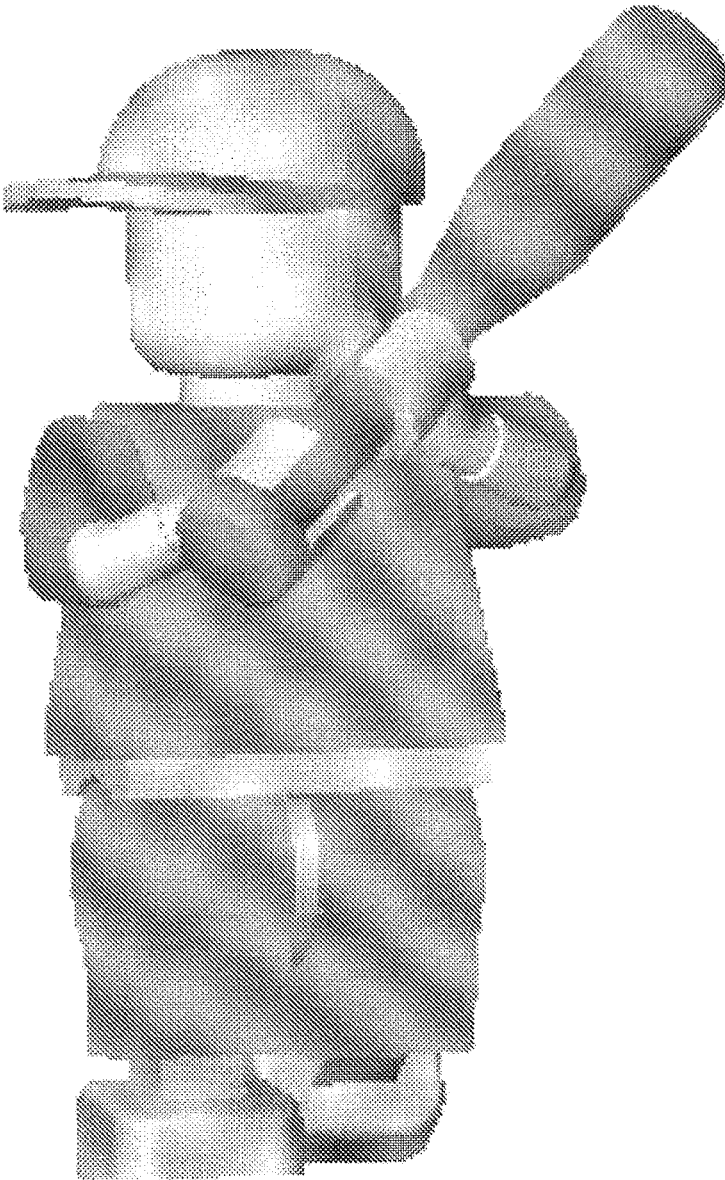

FIG. 52

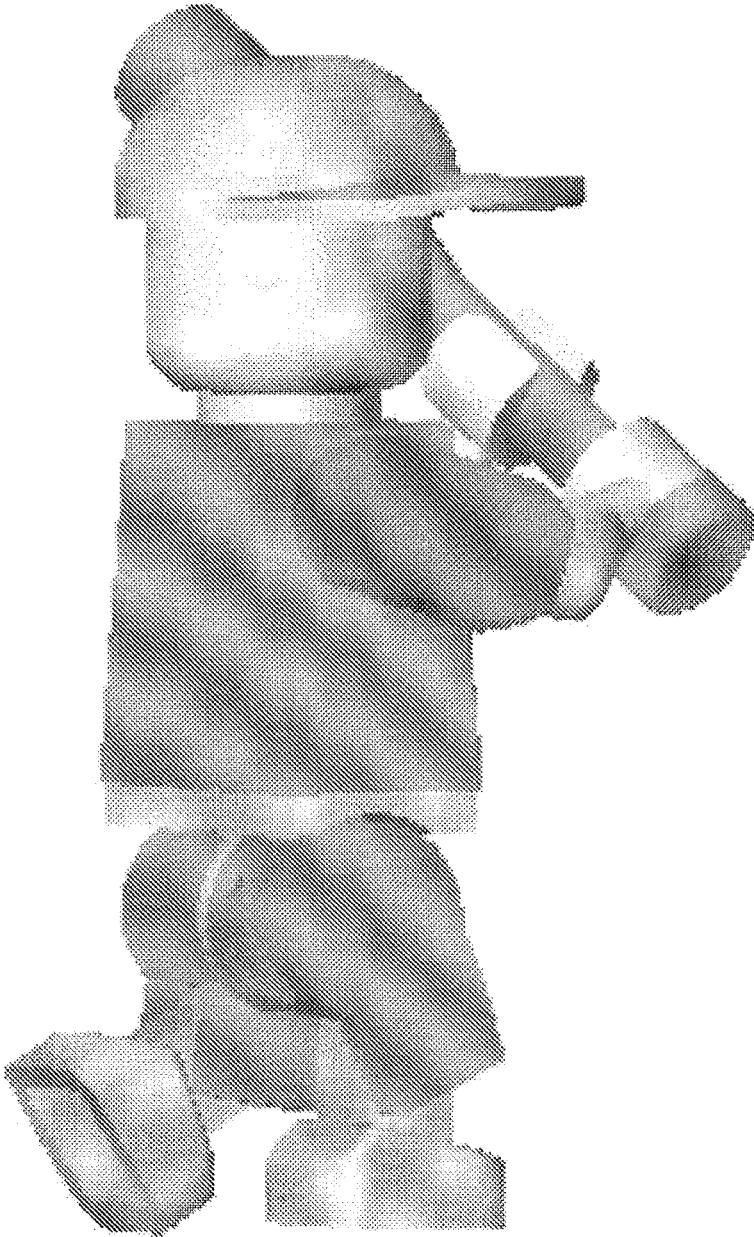

FIG. 53

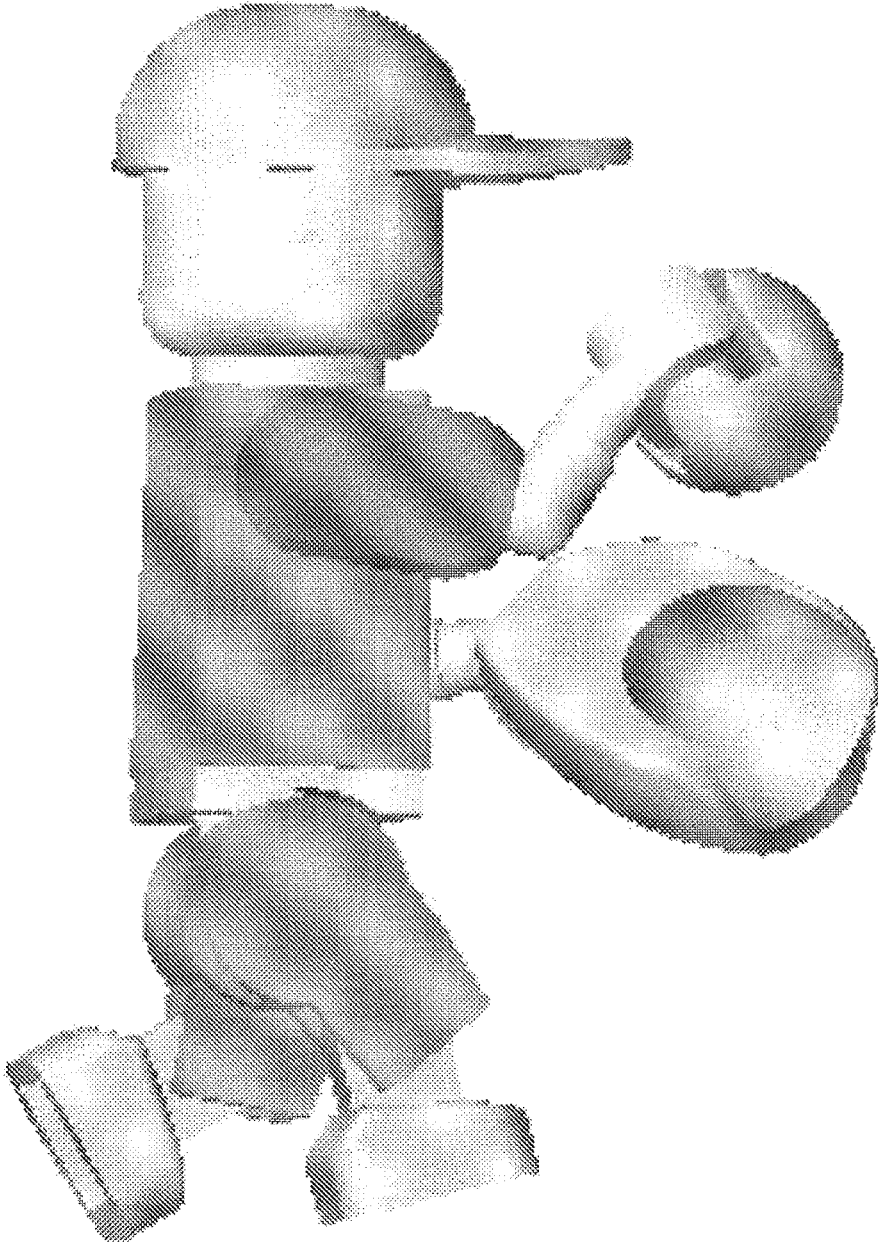

FIG. 54

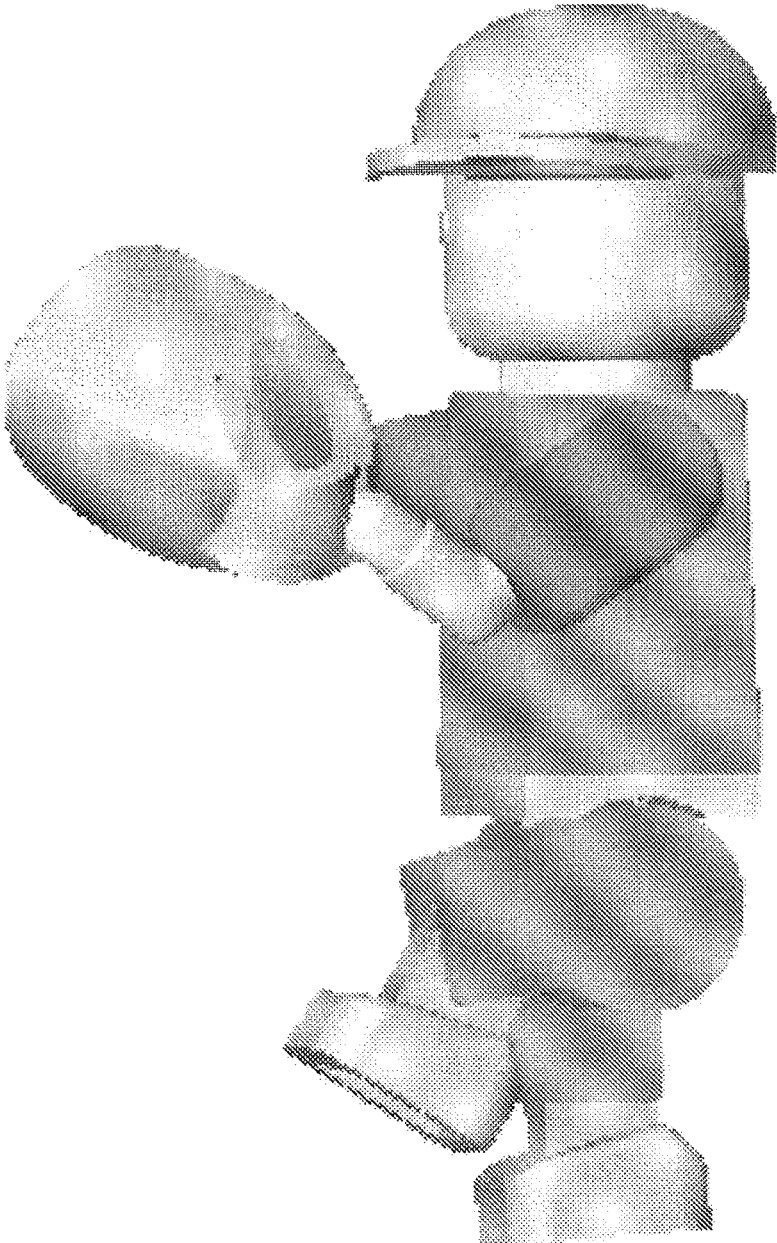

FIG. 55

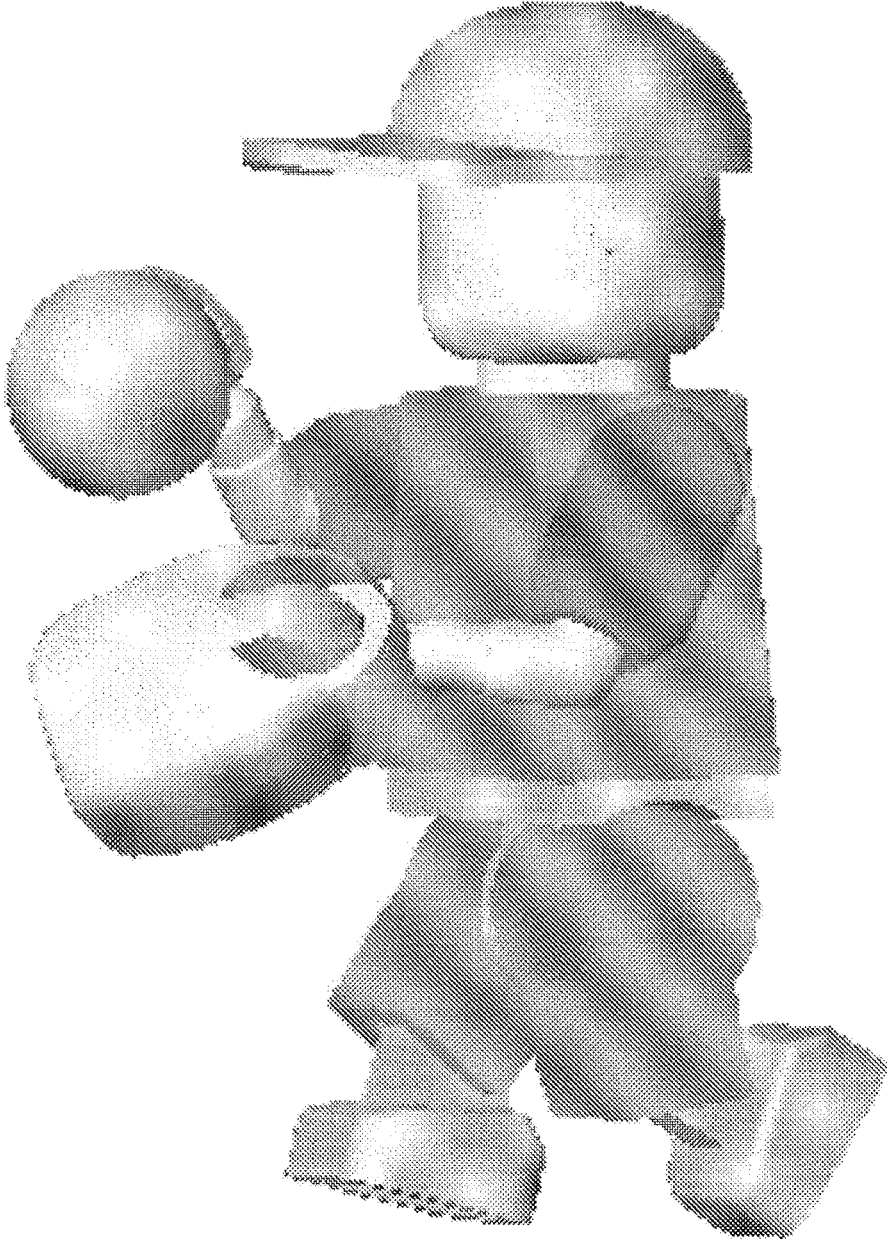

FIG. 56

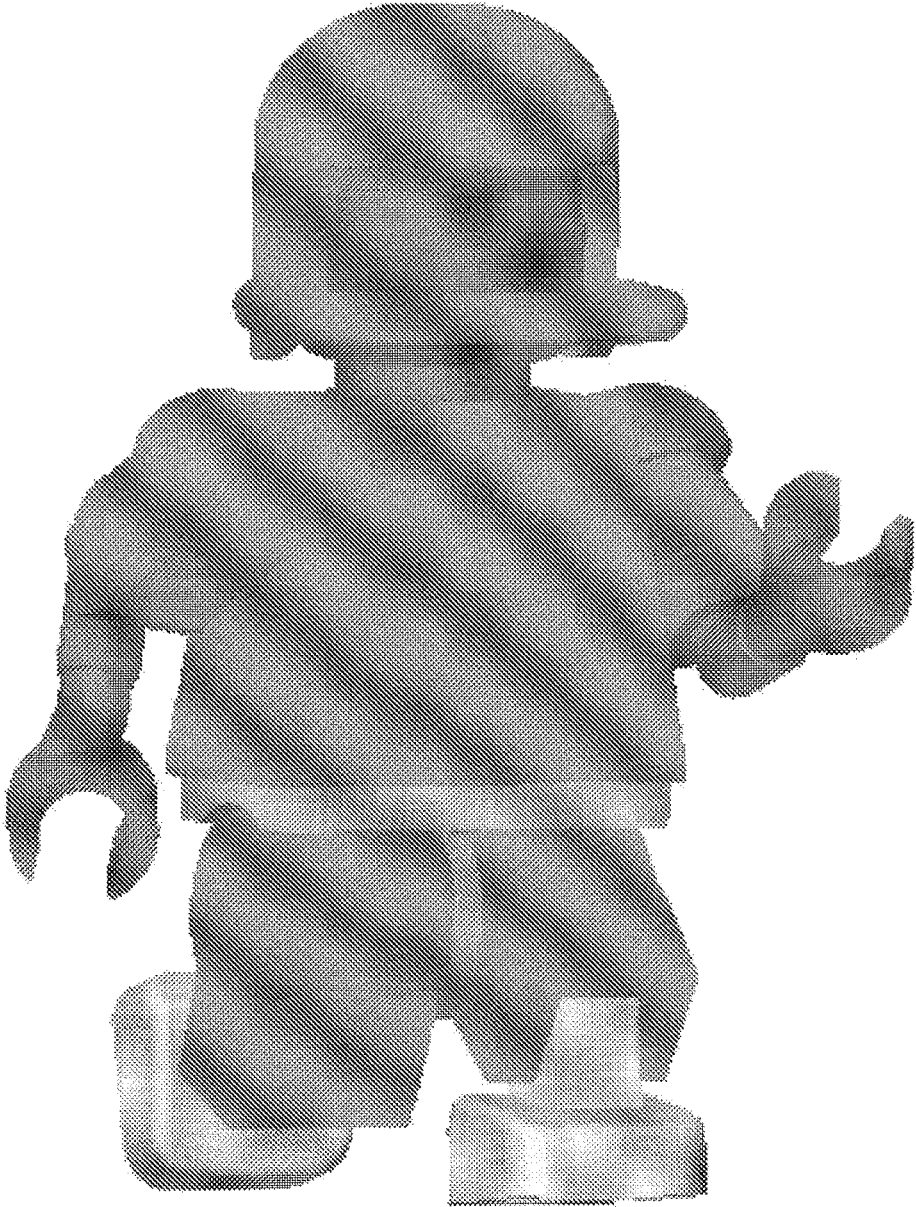

FIG. 57

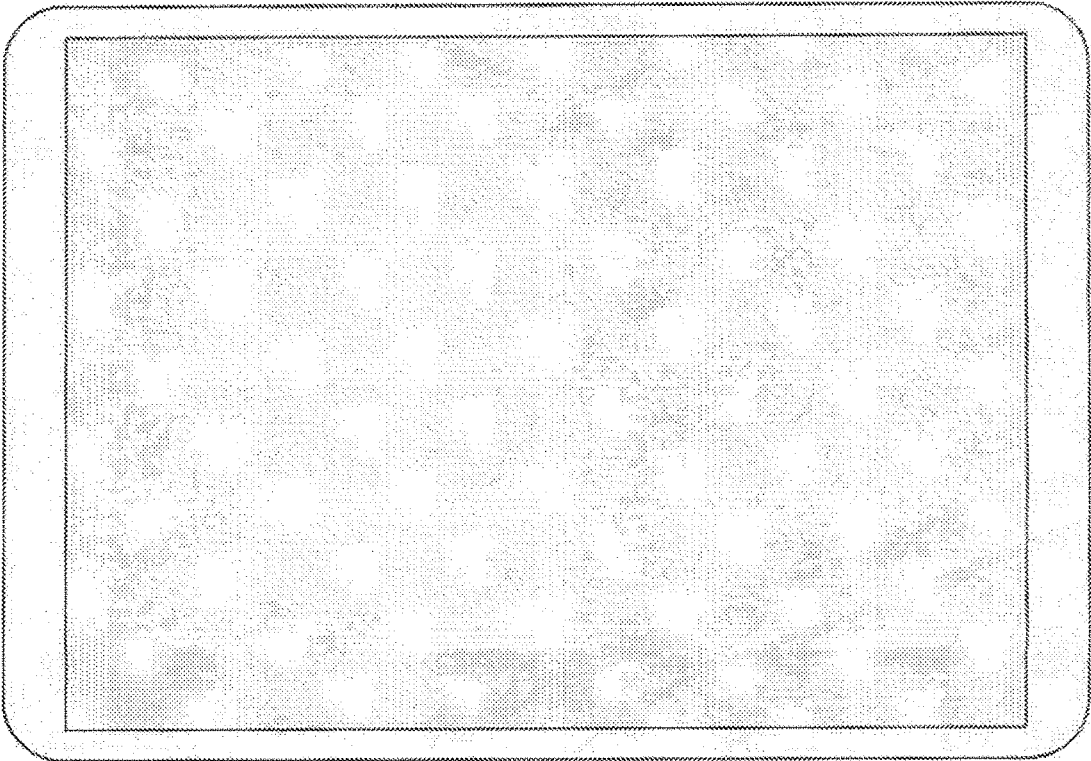

FIG. 58B

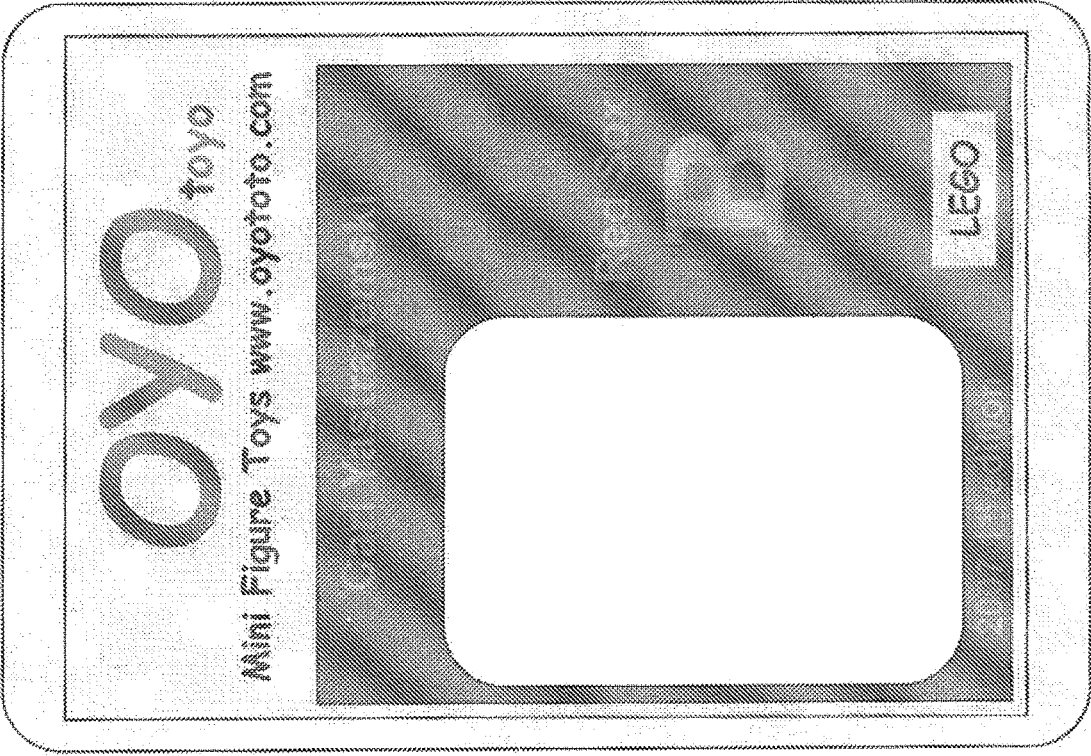
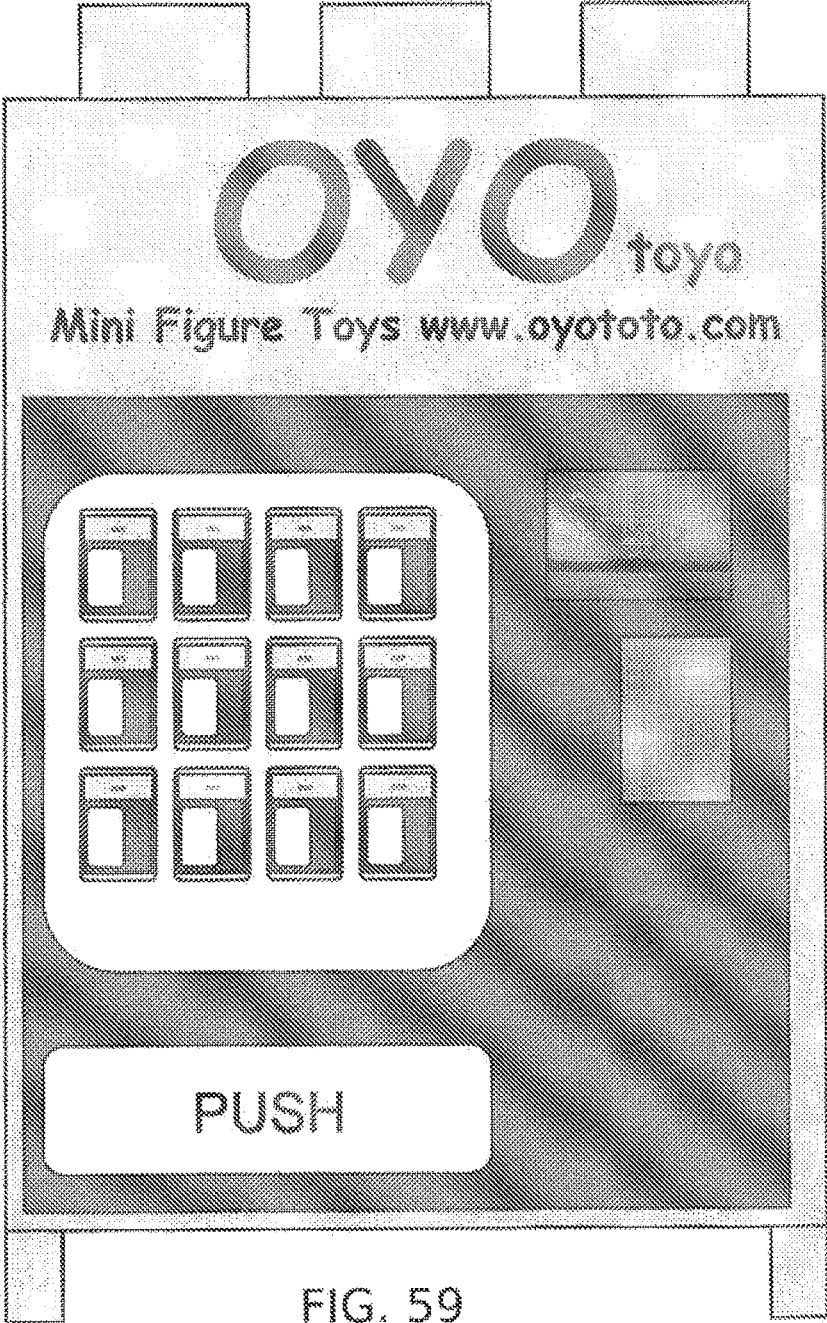

FIG. 58A



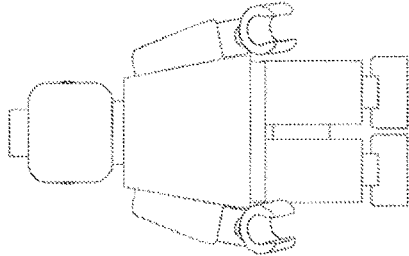

FIG. 60A

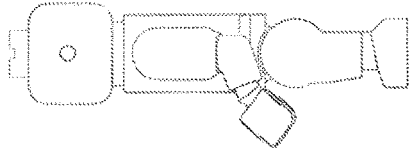

FIG. 60B

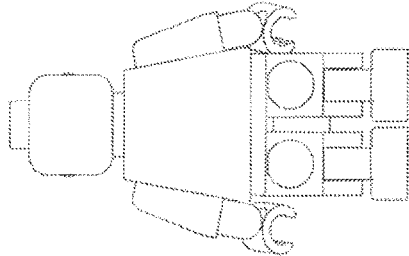

FIG. 60C

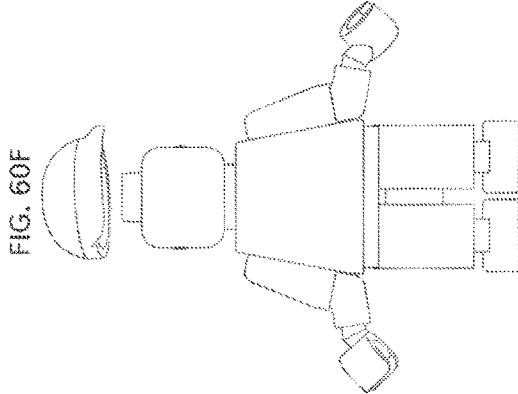

FIG. 60F

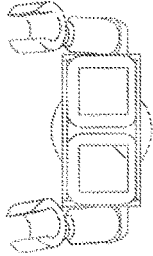

FIG. 60D

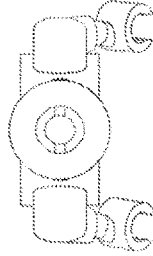

FIG. 60E

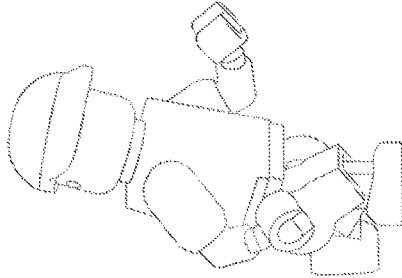

FIG. 60G

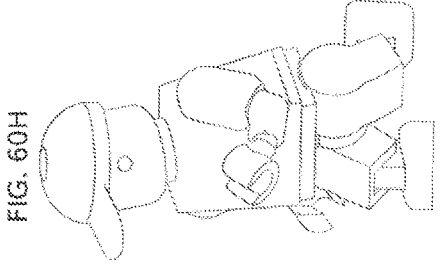
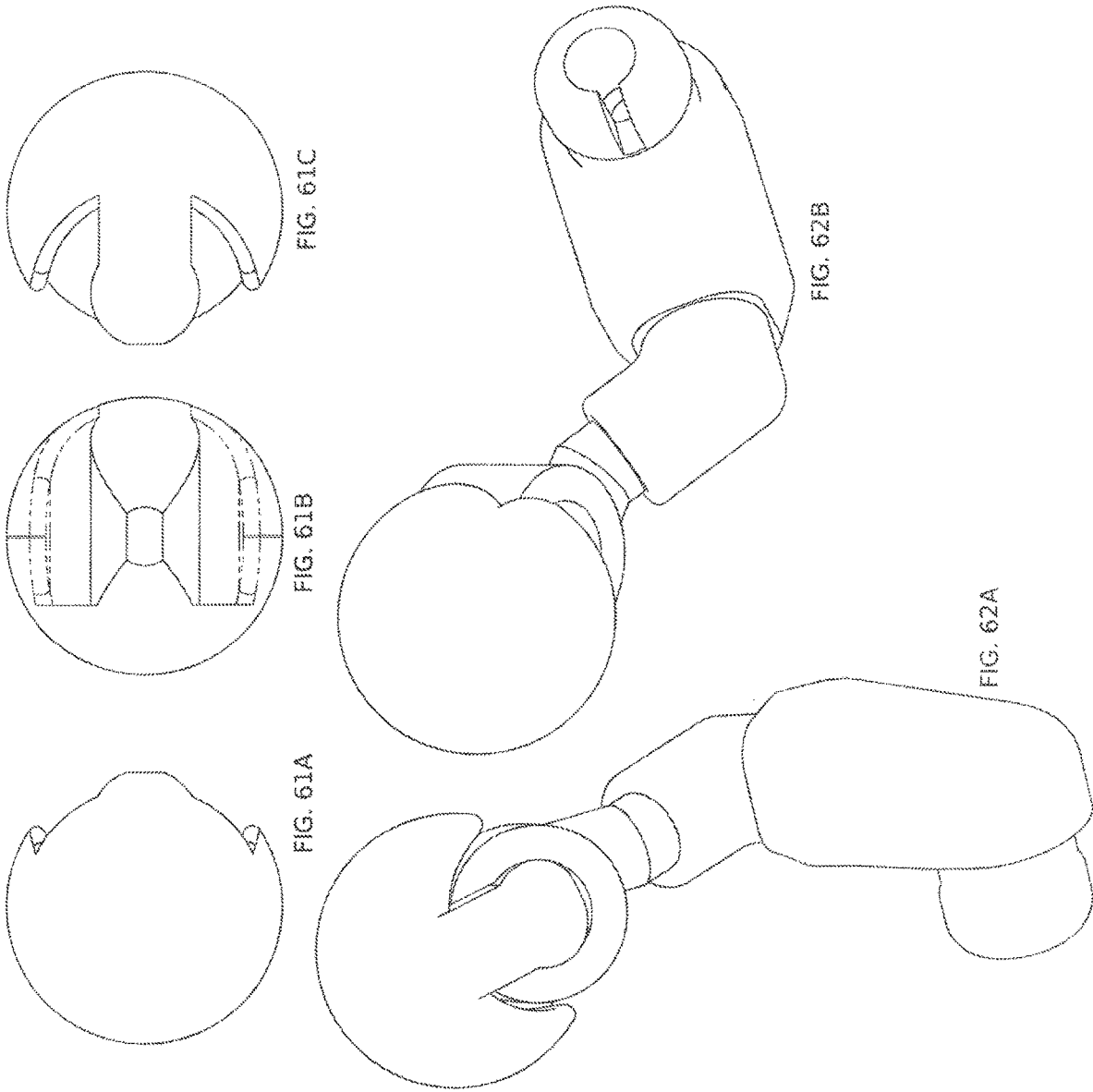
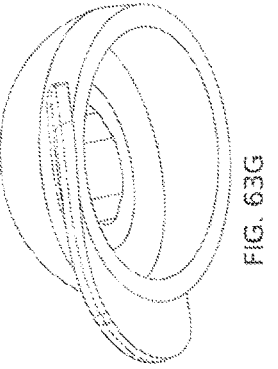
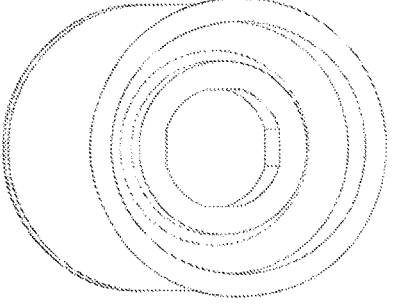
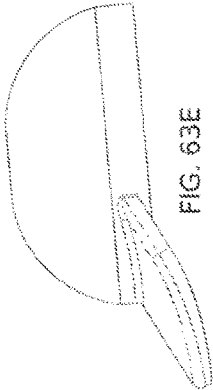
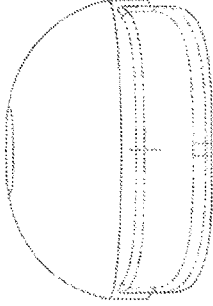
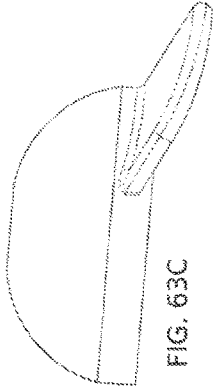
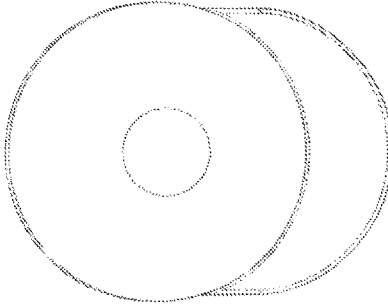
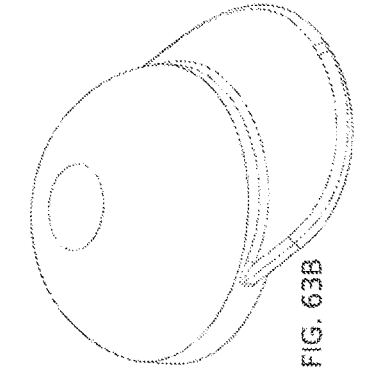

FIG. 60H





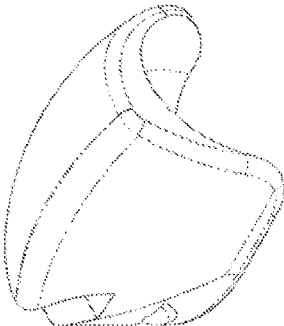

FIG. 64C

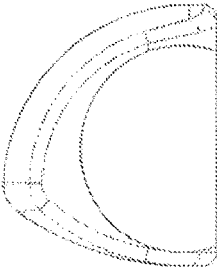

FIG. 64F

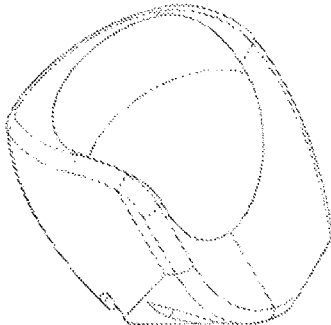

FIG. 64I

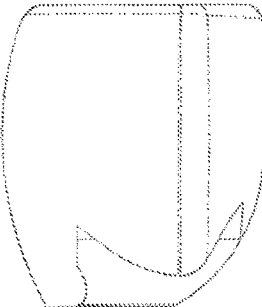

FIG. 64B

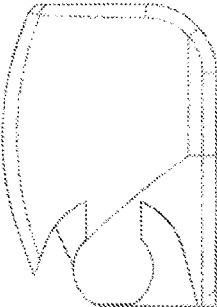

FIG. 64E

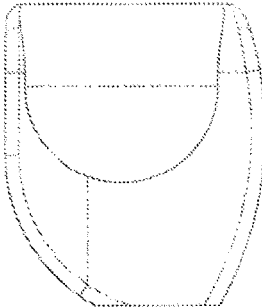

FIG. 64H

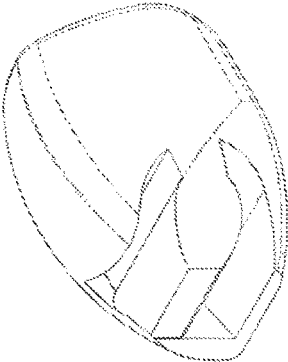

FIG. 64A

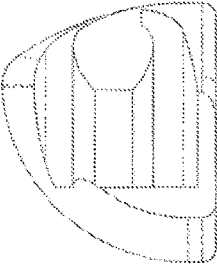

FIG. 64D

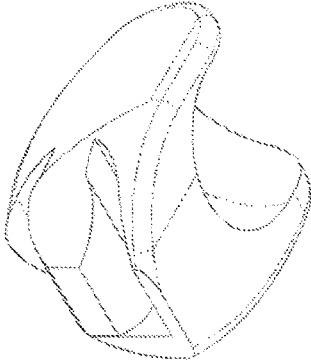

FIG. 64G

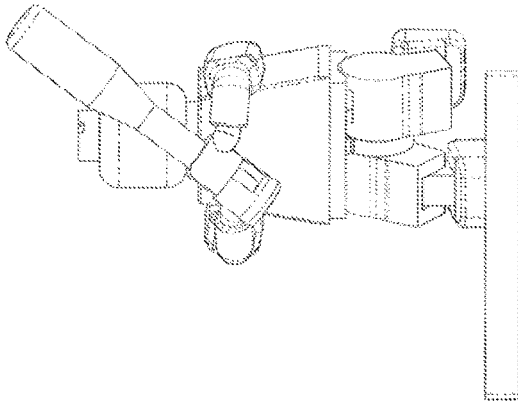

FIG. 65C

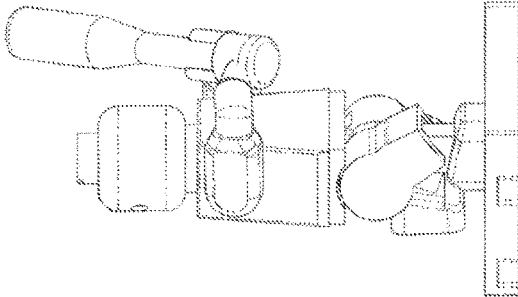

FIG. 65B

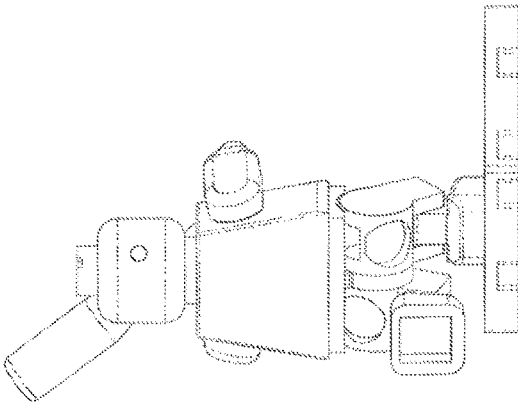

FIG. 65A

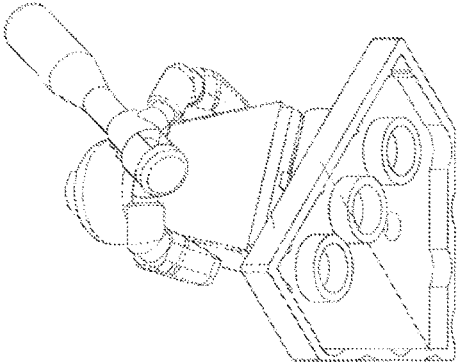

FIG. 65E

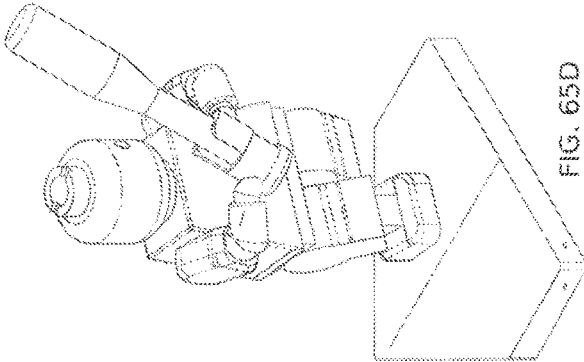

FIG. 65D

**TOY SPORTS-PLAYER FIGURE****CROSS-REFERENCE TO RELATED APPLICATIONS**

This application is a continuation application of and claims priority to U.S. application Ser. No. 17/170,328, filed Feb. 8, 2021, which is a continuation application of and claims priority to U.S. application Ser. No. 14/703,127, filed on May 4, 2015, now U.S. Pat. No. 10,913,006, which is a continuation of U.S. application Ser. No. 13/253,818, filed on Oct. 5, 2011, now U.S. Pat. No. 9,022,832, which claims priority to U.S. application No. 61/389,839, filed Oct. 5, 2010 and titled "TOY SPORTS-PLAYER FIGURINE," each of which is incorporated in its entirety by reference herein.

**COPYRIGHT NOTICE**

A portion of the disclosure of this patent document contains material that is subject to copyright protection. The copyright owner has no objection to the facsimile reproduction by anyone of the patent document or the patent disclosure, as it appears in the Patent and Trademark Office patent file or records, but otherwise reserves all copyright rights whatsoever. Copyright 2011, Oyo Sportstoys, Inc.

**BACKGROUND**

## Field of the Disclosure

The disclosure relates to toys, and more specifically to toy mini-figures depicting sports figures and connectable to toy construction block playsets.

## Background

Toy construction block mini-figures come in many sizes and shapes. A standardized size and shape has been established by dominance of Lego brand blocks. A standard block, and connector type, allows manufacture of mini-figures for use with the standard block and connector for ready acceptance by consumers. Typically mini-figures are marked as components with painted features in component batches, and assembled into the desired mini-figure by selecting the appropriate component.

Legos and similar building blocks are long existing toys. Initial figurines were scaled to connect to a single tab on the blocks. At that scale, no moving parts were included, but rather single "blocks" were decorated to appear as figurines.

The original Lego mini-figure can be seen in U.S. Design PAT. No. D253,711 (Christiansen et al., Dec. 18, 1979) and U.S. Pat. No. 4,205,482 (Christiansen et al., Jun. 3, 1980). These mini-figures, about 1.5 inches tall, include a head attached to a torso component, two arm components which pivot at the connection to the torso in the shoulder region, a hip component connected to the bottom of the torso, and two leg components connected to and pivotal from the hip component. Feet are part of the bottom of the legs, with recesses or channels in the back of the legs and bottom of the feet allowing connection to studs from building blocks. Curved hand components extend out of each arm. To create different character mini-figures, different designs, stickers, or coloring may be affixed to different components. Assembling different sets of components based on the same theme may create the appearance of specific characters. Accesso-

ries may be held in the hands or connect to the head, such as weapons, tools, hair, hats, or helmets.

Variations have been introduced since the original mini-figure. Larger figures have been created. Themed figures have been created. Specialized components have been created for specific creatures, such as an empty-skeleton torso and related arms and legs for a skeleton. However the shape and points of motion of the mini-figure has largely remained unchanged. This is largely due to the durability and scale needed.

**BRIEF SUMMARY**

Disclosed herein is a mini-figure that may be used with existing and standard toy block systems and also have the appearance of a sports figure. Improvements over traditional mini-figures include additional separate components in the arms and feet, an optional variation in torso shape, accessories which create visual impression of sports figures in natural use, unique markings identifiable by specific player or production, and a unique method of marketing and distribution.

An embodiment includes creation of the arm through two components—a shoulder component and a forearm component. The shoulder component may connect to the torso as traditional arms of mini-figures connect. The forearm may connect to the shoulder such that the forearm may pivot at the connection. This allows two points of motion for an arm, allowing hands connected to both arms to come into alignment such as for holding a baseball bat in a traditional baseball grip.

An embodiment includes a foot component which is connectable to and a leg and may pivot from that connection. Separation into a separate foot component allows positioning into active poses by bending at both the ankle and waste, such as creation of a running pose or batting stance, while still allowing the feet to rest on a flat surface or connect to traditional tabs on toy blocks.

Optional embodiments include variation of the traditional torso component. The torso may be made from multiple separable components, such as for creation of cheerleaders with variable outfits. Alternatively the torso may have a natural bend depicting typical sports stance, such as may be seen in hockey players.

Sports accessories may be included with sports mini-figures, or included on components of the mini-figures. For example, balls, gloves, and sticks may be included. Stick-like accessories may include narrow regions for grip by hands. Balls and gloves, which traditionally are not grippable by mini-figures, may have one side specifically shaped to fit with traditional mini-figure hand shapes. This allows sports figures to hold their appropriate accessories. In addition to separate pieces, separation of arms and feet allows further customization. For example, shoulder pads may be included on shoulder component and vary by sport, and sport-specific shoe designs may be included on foot components. This allows further customization by component than is possible with single arm or combined foot and leg components.

An embodiment includes unique markings on one or more components in each mini-figure. Mini-figures are traditionally mass produced, but individualization by sets or other indicia allows increased commercial value and collectability of specific mini-figures.

Along with specific marking, vending machine or interactive displays may be used to distribute mini-figures and increase commercial appeal.

#### BRIEF DESCRIPTION OF THE DRAWINGS

In the drawings, closely related figures and items have the same number but different alphabetic suffixes. Processes, states, statuses, and databases are named for their respective functions.

FIG. 1 shows a sports mini-figure holding a bat and connected to a display plate.

FIG. 2A shows a traditional mini-figure and FIG. 2B shows a mini-figure having multi-component arms and separate-component feet, with relative heights approximately equal between both mini-figures.

FIG. 3 shows a shoulder component connected to a forearm component connected to a hand component with axis of rotation illustrated.

FIG. 4 shows a set of facial designs for head components, in this case a set of baseball players from the same baseball team.

FIG. 5 shows a mini-figure with display plate in a distribution box for display purposes.

FIG. 6 shows the back of a distribution box.

FIG. 7 shows a side view of the distribution box illustrating a clamp-shell design allowing a mini-figure and display plate to be packaged together, including holding the mini-figure in assembled position or stance.

FIG. 8A shows serialized markings on multiple components of a mini-figure, each component bearing the same serialized set number. FIG. 8B depicts a printing or label customized for a specific player and component.

FIG. 9 shows a display plate with sports-related information associated with a specific player.

FIG. 10 shows an arm with the hand component holding a football accessory.

FIG. 11 shows an arm in a stiff-arm block position.

FIG. 12 shows an arm holding a football accessory in a throwing position.

FIG. 13 shows an arm holding a baseball accessory in a throwing position.

FIG. 14 shows a baseball glove accessory.

FIG. 15 shows a baseball accessory sized to fit in the baseball glove accessory of FIG. 14.

FIG. 16 shows a baseball accessory.

FIG. 17 shows a baseball rotated to reveal a grip nestable within the hand of a mini-figure.

FIG. 18 shows a baseball with the grip partially complete.

FIG. 19 shows a football accessory.

FIG. 20 shows a football rotated to reveal a grip nestable within the hand of a mini-figure.

FIG. 21 shows a hockey mini-figure with angled torso.

FIG. 22 shows a cheerleader mini-figure.

FIG. 23 shows a cheerleader torso separated into two components.

FIG. 24A shows a vending machine and FIG. 24B shows a point-of-purchase display.

FIG. 25 shows a vending machine with interactive display.

FIG. 26 shows a football player mini-figure.

FIG. 27 shows an arm of a football player mini-figure with pads and muscles.

FIG. 28 shows a hockey player mini-figure.

FIG. 29 shows a bending forearm component.

FIG. 30 shows a foot component designed to appear as a hockey skate.

FIG. 31 shows a magnetic insert that fits into a foot component.

FIG. 32 shows a magnetic surface.

FIG. 33 shows a magnetic surface appearing to be a football field.

FIG. 34 shows a virtual/real playing surface having controlled locations of magnetic position, with magnets also shown having a magnetic core surrounded by a buffer zone.

FIG. 35A and FIG. 35B show touch-based controls of the magnetic playing surface.

FIG. 36 shows multiple stations for holding and variably printing mini-figure components.

FIG. 37 shows a rotational printing station for printing on mini-figure heads.

FIGS. 38A-E show multiple views of a torso component. FIG. 38A shows a perspective view, FIG. 38B shows a top-down view, FIG. 38C shows a wide-side view; FIG. 38D shows a bottom-up view, and FIG. 38E shows a narrow-side view.

FIGS. 39A-E show multiple views of a forearm component. FIG. 39A shows a perspective view, FIG. 39B shows a side view of the component laid flat, FIG. 39C shows a view looking into the hand-side end, FIG. 39D shows a side view of the component tilted up, and FIG. 39E shows an interior slice view.

FIGS. 40A-E show multiple views of a hand component. FIG. 40A shows a perspective view, FIG. 40B shows an end view, FIG. 40C shows top view, FIG. 40D shows a side view, and FIG. 40E shows an interior slice view.

FIGS. 41A-E show multiple views of an upper arm or shoulder component. FIG. 41A shows a perspective view, FIG. 41B shows a side view, FIG. 41C shows a close up view of the connector the enters the torso component, FIG. 41D shows torso-side view, and FIG. 41E shows a forearm-end view.

FIGS. 42A-F show multiple views of a head component. FIG. 42A shows a perspective view, FIG. 42B shows a top view, FIG. 42C shows a back view, FIG. 42D shows a side view, FIG. 42E shows an interior slice view, and FIG. 42F shows a close-up view of the ear.

FIGS. 43A-D show multiple views of a hip component. FIG. 43A shows a perspective view, FIG. 43B shows a top view, FIG. 43C shows a front view, and FIG. 43D shows a side view.

FIGS. 44A-F show multiple views of a left leg component. FIG. 44A shows a perspective view, FIG. 44B shows a bottom view, FIG. 44C shows an interior slice view from the side, FIG. 44D shows a side view, FIG. 44E shows an interior slice view from the front, FIG. 44F shows a back view.

FIGS. 45A-F show multiple views of a foot component. FIG. 45A shows a perspective view, FIG. 45B shows a bottom view, FIG. 45C shows a side view, FIG. 45D shows a front view, FIG. 45E shows an interior slice view, and FIG. 45F shows another interior slice view.

FIGS. 46A-E show multiple views of a right leg component. FIG. 46A shows a perspective view, FIG. 46B shows a bottom view, FIG. 46C shows a side view, FIG. 46D shows an interior slice view, and FIG. 46E shows a back view.

FIGS. 47A-C show multiple views of a bat accessory. FIG. 47A shows a perspective view, FIG. 47B shows a side view, and FIG. 47C shows a top view.

FIGS. 48A-F show multiple views of a hat accessory. FIG. 48A shows a perspective view, FIG. 48B shows a top view, FIG. 48C shows a side view, FIG. 48D shows a bottom view, FIG. 48E shows a front view, and FIG. 48F shows an interior slice view.

FIGS. 49A-E show multiple views of a ball accessory. FIG. 49A shows a perspective view, FIG. 49B shows a top view, FIG. 49C shows a side view, FIG. 49D shows a back view, and FIG. 49E shows an interior slice view.

FIGS. 50A-D show multiple views of an alternative ball accessory. FIG. 50A shows a perspective view, FIG. 50B shows a top view, FIG. 50C shows an interior slice, and FIG. 50D shows another interior slice on a different axis.

FIGS. 51A-E show multiple views of a baseball glove accessory. FIG. 51A shows a perspective view, FIG. 51B shows a top view, FIG. 51C shows a side view, FIG. 51D shows a front view, and FIG. 51E shows an interior slice view.

FIG. 52 shows a front view of a baseball mini-figure holding a bat.

FIG. 53 shows a side view of a baseball mini-figure holding a bat.

FIG. 54 shows a side view of a baseball mini-figure holding a glove and a ball.

FIG. 55 shows a side view of a baseball mini-figure with glove in a pitching position.

FIG. 56 shows a front view of a baseball mini-figure holding a glove and ball and in a throwing position.

FIG. 57 shows a football mini-figure.

FIGS. 58A-B show packaging for a mini-figure sales display case, with visible card having a display side, FIG. 58A, and a back side, FIG. 58B.

FIG. 59 shows a vending machine for mini-figures.

FIGS. 60A-H show multiple perspective views of a mini-figure with multi-component arms and separate component legs and feet. FIG. 60A shows a front view, FIG. 60B shows a side view, FIG. 60C shows a back view, FIG. 60D shows a bottom view, FIG. 60E shows a top view, FIG. 60F shows a front view with forearm rotated away from the mini-figure, FIG. 60G shows a running perspective, and FIG. 60H shows a running perspective from the other side.

FIGS. 61A-C show multiple perspective views of a ball accessory.

FIGS. 62A-B show multiple views of a multi-component arm connected to a ball.

FIGS. 63A-G show multiple perspective views of a hat accessory.

FIGS. 64A-1 show multiple perspective views of a glove accessory.

FIGS. 65A-E show multiple perspective views of a baseball mini-figure holding a bat and standing on a baseball plate with standard block tabs for connectors.

#### DETAILED DESCRIPTION OF THE INVENTION

In the following detailed description of the invention, reference is made to the accompanying drawings which form a part hereof, and in which are shown, by way of illustration, specific embodiments in which the invention may be practiced. It is to be understood that other embodiments may be used, and structural changes may be made without departing from the scope of the present invention.

A preferred embodiment is a mini-figure with improvements over traditional mini-figures allowing more accurate appearance and positioning creating a sports mini-figure. Such improvement is enabled through arm, leg, torso, and accessory features.

Referring to FIG. 1, a baseball mini-figure is shown holding a bat in a batting position. Such arrangement is not possible with prior mini-figures, as the hands could not be positioned near to each other or across the body to hold a bat

as in a baseball bat grip, nor do prior mini-figures bend at an ankle level to allow athletic-looking stances such as a the shown batting stance. Despite these differences, the improved sports mini-figure may be used with prior playsets as if it were a prior mini-figure, and connect to building block tabs the same as prior mini-figures. Referring also to FIG. 2, the improved sports mini-figure is shown to be of the same scale and overall general appearance as a prior mini-figure. In the preferred embodiment, the height of the improved sports mini-figure is approximately 1.56 inches.

Referring also to FIG. 3, a complete arm is shown. The complete arm includes three components, an upper arm or shoulder component 30 (see also FIG. 41), a forearm component 32 (see also FIG. 39), and a hand component 34 (see also FIG. 40). The upper arm component 30 connects to the torso, where the connection may be the same as in prior mini-figures, allowing the arm to pivot in a plane adjacent to the side of the torso. The forearm component 32 connects to the upper arm component 30 through an interference-fitted cylindrical connection 36. The forearm component 32 may be bent at an angle just below the end of connection to the upper arm component 30. This provides appearance of a bent elbow. The lower arm 32 may rotate about an axis parallel to the upper arm 30 and defined by a line between the shoulder of the upper arm 30 and elbow of the forearm 32. This second point of rotation allows the forearm 32 to be positioned across or away from the body of a mini-figure. The hand component 34 connects to the forearm 32 through an interference-fitted cylindrical connection 38, which may be the same as in prior mini-figures. Inward reach and ability to align hands is enabled by the additional point of rotation and allows the mini-figure to hold a bat in a traditional batting grip or hold sports equipment in both hands in traditional positions associated with the sport.

Referring also to FIGS. 44, 45, and 46, a foot component may be connected to each leg component allowing pivot of the foot up or down while still aligned straightforward relative to the leg. This allows a point of rotation additional to leg rotation at the hip. This additional point creates a visual appearance of an ankle or knee (a lower-leg point of rotation). This in turn allows positioning into traditional athletic poses, such as a baseball player squatting into a batting stance, a player running, or a pitcher striding to throw. The bottom of the foot component has a recess designed to accept tabs from traditional building blocks, allowing connection of the sports mini-figure to the building block through the foot.

Referring also to FIGS. 21, 22, and 23, some embodiments may include variations in the torso component. A skating hockey player has a traditional bent upper body position. This may be implemented by a torso component having an angled position to the axis of rotation of the head. Alternatively, cheerleaders may be created with non-traditional torso components. The torso component may be comprised of two separate components, allowing an upper chest and lower torso. This allows more accurate mini-figure depiction of cheerleaders, including bikini top, cleavage, skinny waist. Delineation of the torso portions may be either above or below the breasts, but should be consistent across mini-figure cheerleaders to allow consistent swapping of torso sub-components.

Sports accessories may be included with sports mini-figures, or included on components of the mini-figures. Baseball bats, hockey sticks, lacrosse sticks, and other sports equipment may be included. Due to the flexible arm posing enabled by multi-segment arms, bats and sticks may have regions for gripping by the mini-figure hands that corre-

spond to where real-life athletes would grip the bat or stick. Sports balls, gloves, and cheerleading equipment may also be made into accessories. One or two-handed accessories, which traditionally are not grippable by mini-figures, may have one side specifically shaped to fit with traditional mini-figure hand shapes. This allows sports figures to hold their appropriate accessories. Referring to FIGS. 14-20, a baseball glove, baseball, and football are shown with recesses on one side of each accessory allowing fit with mini-figure hands. Such cylindrical cut into the accessory allows interference fit with a hand to hold the accessory and present appearance of the object. Accessories which go together, such as a baseball and glove, may also be sized for interference fit such that the ball may fit and hold within the glove. Referring also to FIGS. 26, 27, 28, and 33, accessories may also be designed onto mini-figure components. For example, shoulder pads may be designed as part of upper-arm components for football players. Different tattoo design may be included in upper-arm components for different basketball players. Ice skates may be designed as part of foot components for hockey players. Different sneaker design may be designed as part of foot components for different athletes. This allows finely tuned specifics of more components, allowing more customization of individual mini-figures than previously possible.

Referring also to FIG. 30, an additional accessory may be a magnetic component which fits into the recess in a foot component. The magnetic component may include a cavity to enable easy removal. Inclusion of the magnetic component enables the mini-figure to secure stably to a flat surface in a standing or athletic position as long as the foot is flat on the surface. Referring also to FIGS. 31 and 32, the surface may be magnetic, and may be shaped and marked as an athletic performance venue such as a sports field, court, or rink. The surface may have localized magnetic positions to allow a player to be restrained or controlled by the location of the magnetic feature. Referring also to FIGS. 33 and 34, moving the magnetic feature may allow the mini-figure to move on the surface, and may be controlled by a user interface.

Referring also to FIG. 8, specific features of individual athletes, such as facial features, uniform numbers, name, or statistics may be included on individual components. This allows identifying each individual component with a specific player represented by a mini-figure. An unique number or serial number may be included for collectability purposes. Referring also to FIGS. 36 and 37, such marking may be done using a printer that prints directly on components and may be done individually, as a set, or on assembled mini-figures. The printer may have a tray for holding at least one figure allowing the components to be marked as a serialized set. This may also allow an array of figures to be printed during the same print with or without any variations in the array. For example, components may be arranged by sports team and skin tone, configured in an array of trays and printed in batches allowing rapid change and reproduction during a sports season. Alternatively, an individualized printer may hold one mini-figure having specific team markings. A user interface may select name and number to print on the specific mini-figure. Such customization may be done at a manufacturing facility, or at an end-sales location such as a store controlled by a purchaser or sales attendant.

In addition to customization by end-purchasers, referring also to FIGS. 24 and 25 another method to better enable the distribution of the mini-figures is to provide an easily identifiable display. Such display may include a housing structure for organizing packaged mini-figures and an inter-

active interface to attract customers. The interface may be motion sensitive to direct audio to customers passing by. The audio may be preprogrammed or instant communication fed through wireless or remote locations. As shown in FIG. 25, a mini-figure may be displayed with audio output as discussed above, such as saying "HEY! Let me out of here!" or "Welcome to the Boladrome!" Motion sensor 2520 may detect when anyone approaches, triggering the audio. RFID sensor 2510 may detect when mini-figures are purchased, with RFID 2540 included in each mini-figure package. Interactive display 2530 is programmable for different modes to interact with customers, including web-linked ads. Interactive access panel 2550 allows customer interaction, and may include web access to allow search and inventory listings of both the local machine and other machines or displays accessible via the web. An alternative sales display is a matrixed vending machine. This allows a customer to select a player mini-figure and purchase without requiring a store location. The interactive display may be incorporated into the vending machine. The vending machine may be transmit sales and inventory information to a web server allowing online inventory search by owners or customers to identify available mini-figures at specific locations.

It is to be understood that the above description is intended to be illustrative, and not restrictive. Many other embodiments will be apparent to those of skill in the art upon reviewing the above description. The scope of the invention should, therefore, be determined with reference to the appended claims, along with the full scope of equivalents to which such claims are entitled.

The invention claimed is:

1. A toy figurine comprising:

a torso component;

an arm component connected to the torso component, the arm component being movable relative to the torso component, wherein the arm component comprises:

an upper arm component comprising a cylindrical portion received in an opening of the torso component, the upper arm component movable relative to the torso component about a first rotational axis defined by a centerline of the opening of the torso component, the upper arm component comprising an opening positioned such that a centerline of the opening of the upper arm component intersects the centerline of the opening of the torso component; and

a forearm component having a cylindrical portion received in the opening of the upper arm component, the forearm component movable about a second rotational axis defined by the centerline of the opening of the upper arm component, the forearm component comprising an opening positioned such that a centerline of the opening of the forearm component intersects the centerline of the opening of the upper arm component; and

wherein movement of the forearm component about the second rotational axis defined by the centerline of the opening of the upper arm component changes the distance between the torso component and the opening of the forearm component.

2. The toy figurine of claim 1, wherein the toy figurine includes a first upper leg component and a second upper leg component, each upper leg component configured to pivot relative to the torso component.

3. The toy figurine of claim 2, wherein the cylindrical portion of the forearm component comprises a cylindrical post and a cylindrical band on said post, the cylindrical post

9

having a first diameter and the cylindrical band having a second diameter larger than the first diameter, the second diameter being larger than a diameter of the opening of the upper arm component.

4. The toy figurine of claim 1, further comprising a hand connected to the arm component and spaced apart from the torso component, the hand including a first recess.

5. The toy figurine of claim 4, wherein the hand comprises a cylindrical portion received in the opening of the forearm component, the hand being extendable along the centerline of the opening of the forearm.

6. The toy figurine of claim 5, wherein the cylindrical portion of the hand has a cylindrical post and a cylindrical band on said post, the cylindrical post having a first diameter and the cylindrical band having a second diameter larger than the first diameter, the second diameter being larger than a diameter of the opening of the forearm component.

7. The toy figurine of claim 5, wherein the cylindrical portion of the forearm component has a cylindrical post and a cylindrical band on said post, the cylindrical post having a first diameter and the cylindrical band having a second diameter larger than the first diameter, the second diameter being larger than a diameter of the opening of the upper arm component.

8. The toy figurine of claim 4, further comprising a removable sporting accessory that comprises a recess that receives a portion of the hand.

10

9. The toy figurine of claim 8, wherein a portion of the removable sporting accessory comprises a spherical geometry.

10. The toy figurine of claim 8, wherein a portion of the removable sporting accessory comprises a geometry of a baseball glove.

11. The toy figurine of claim 8, wherein a portion of the removable sporting accessory comprises a geometry of a baseball bat.

12. The toy figurine of claim 8, wherein a portion of the removable sporting accessory comprises a geometry of a football.

13. The toy figurine of claim 8, wherein a portion of the removable sporting accessory comprises an elliptical geometry.

14. The toy figurine of claim 1, further comprising a head component configured to connect to the torso component.

15. The toy figurine of claim 14, further comprising a hat component configured to connect to the head component.

16. The toy figurine of claim 14, wherein the head component is rotatable relative to the torso component.

17. The toy figurine of claim 14, wherein the head component includes a face.

18. The toy figurine of claim 17, wherein the face includes facial hair.

\* \* \* \* \*