

J. J. CLARK.
Telegraphic Register.

No. 9,514.

Patented Jan. 4, 1853.

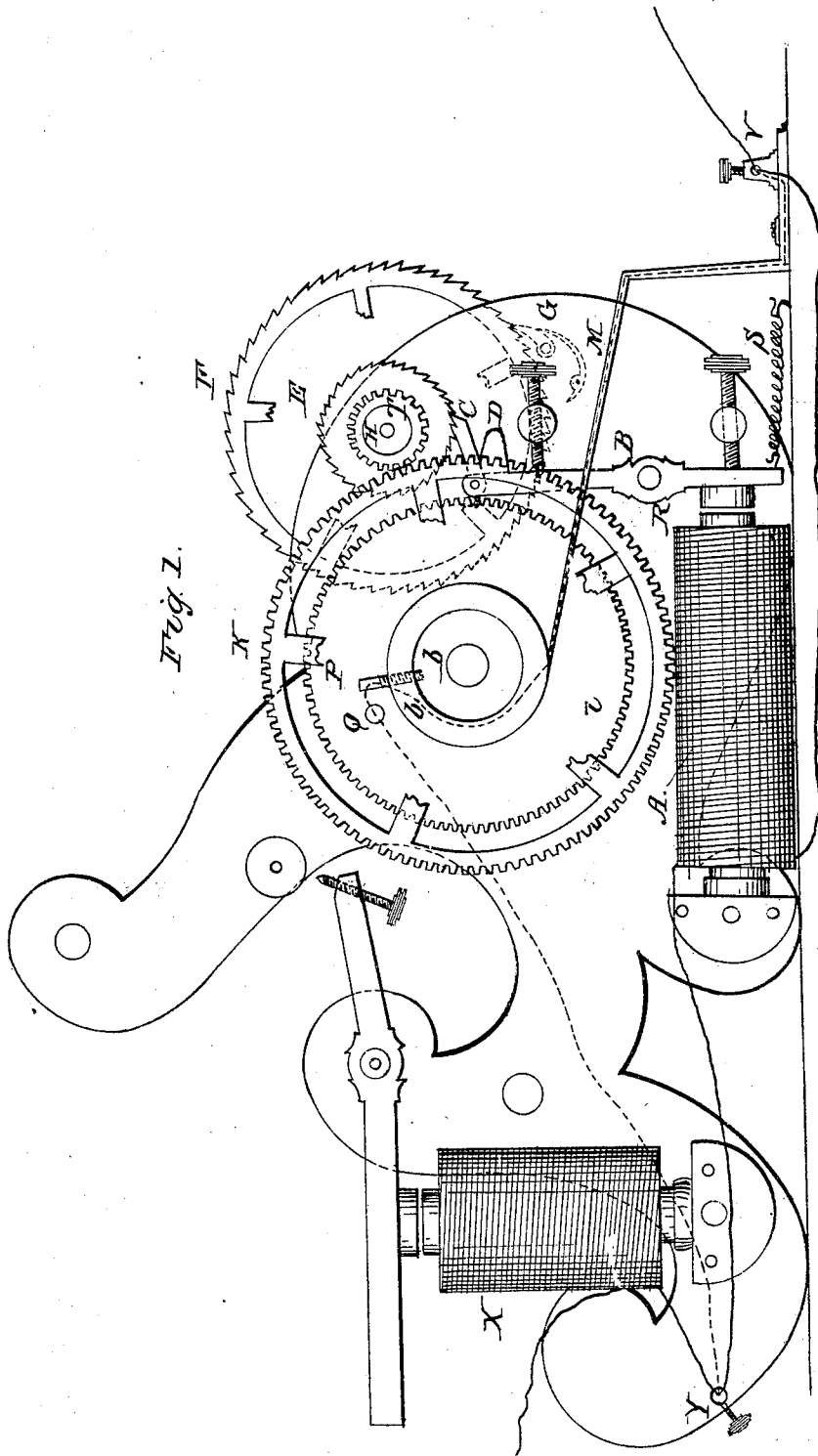

J. J. CLARK.

Telegraphic Register.

No. 9,514.

Patented Jan. 4, 1853.

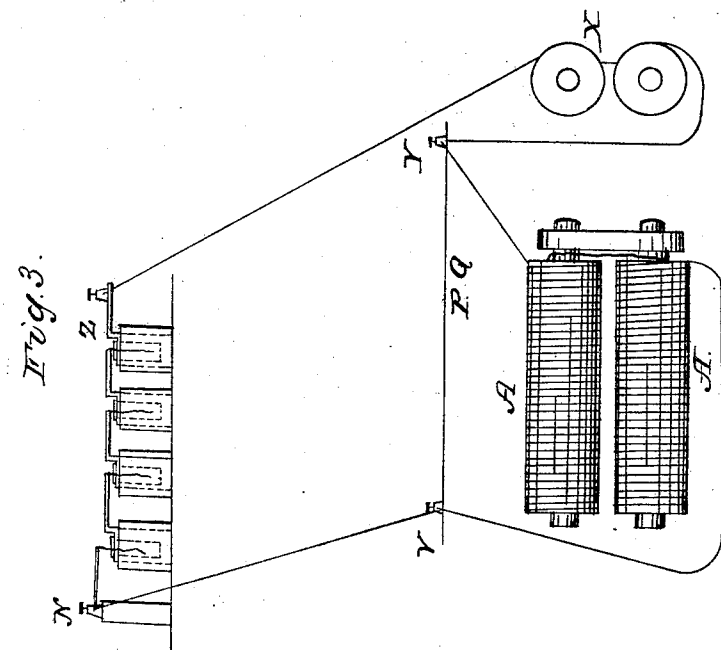
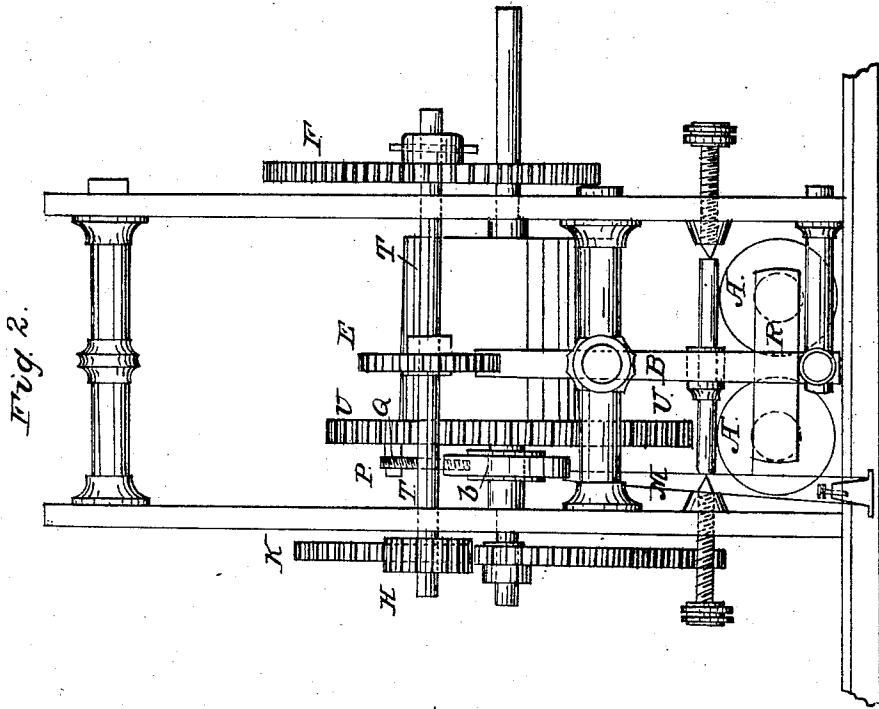

UNITED STATES PATENT OFFICE.

JAMES J. CLARK, OF PHILADELPHIA, PENNSYLVANIA.

IMPROVEMENT IN SELF-WINDING TELEGRAPHIC REGISTERS.

Specification forming part of Letters Patent No. 9,514, dated January 4, 1853.

To all whom it may concern:

Be it known that I, JAMES J. CLARK, of the city and county of Philadelphia, and State of Pennsylvania, have invented a new and useful Improvement in the Construction of Telegraph-Registers, which I denominate the "Self-Winding Register;" and I do hereby declare that the following is a full, clear, and exact description thereof, reference being had to the annexed drawings, in which—

Figure 1 represents a side view or elevation of my improved register, with the nearer side plate removed; Fig. 2, an end view, and Fig. 3 a view of the battery connections hereinafter described.

The arrangement with which my improvement is to be combined consists in attaching an adaptation to the ordinary Morse telegraph-register of a second electro-magnet, (seen at A, Fig. 1,) an armature, R, attached to one extremity of a lever, B, and a click, C, at the other extremity. This click works into a ratchet-wheel, E. To the lower extremity of the lever, behind the armature, a reacting spring, S, is attached. On the shaft T of the ratchet-wheel E another ratchet-wheel, F, of larger diameter, is placed, with a fixed click, G, catching into the teeth of the wheel F at one part of its circumference. On the same shaft with the ratchet-wheels E and F is a small cog-wheel, H, working into another large cog-wheel, K, to the shaft of which last wheel the spring is attached. The other end of the spring is fixed to the box, as in a watch.

The operation of this part of the improvement is as follows: The wire of the local circuit of any Morse-telegraph office, after leaving the local battery at Z, Fig. 3, is made to pass around the coils of the register-magnet X, thence to the brass frame-work of the instrument at Y, thence to the winding-magnet A, thence to another part of the instrument, V, insulated from the rest of the instrument, except by a cross-circuit when the part P is closed, and from V to N. The receiving-magnet of the main telegraphic circuit closes the local circuit. The current of the local circuit passes through the register-magnet X to the winding-magnet A, and through the point V back to the local battery. Thus the armature R is attracted forward and moved back-

ward all the time that the receiving-magnet is in operation. As the armature moves backward and forward the lever B vibrates, and at each vibration revolves the ratchet-wheel E through the space of one tooth or more, according to the set-screw. The second click, G, catches in the ratchet-wheel F and prevents the wheel E, which is on the same shaft, from going back when the click C recedes from the ratchets. The revolution of the ratchet-wheels revolves the cog-wheel H and K, and thus winds up the spring which is the motive power of the register. The spring is confined within a spring-box, and is made, by its elastic force, to rotate the ordinary train of wheels which drag the paper between the pen-point and the roller of the ordinary register.

My improvement consists in an arrangement by which, when the spring is wound up to a certain point, the current through the winding-magnet is cut off by establishing a cross-connection by the points P and Q coming into contact until the instrument has run down a little, when the points P and Q separate, and the current through the winding-magnet is re-established and the winding operation is renewed. By this part of my improvement the spring is always kept wound up to a certain point and prevented from running down or from being wound up too tight. The arrangement of mechanism by which this is effected is shown in Figs. 1 and 2, and is as follows: On the shaft of the spring and revolving with the spring is a small ivory wheel, *b*, with a brass circumference, *b'*, having a metallic arm, P, projecting radially out from it. To the wheel U, which revolves with the spring-box, a small side metallic projection, Q, is fixed. Against the brass circumference *b'* the spring M presses. The circuit is so arranged that when P touches Q a cross-circuit is established from the register-magnet through the body of the instrument, through Q to P, along the spring M; thence back to the battery, thus cutting off the circuit through the winding-magnet and throwing it out of operation. As the instrument runs down the projection Q rotates in advance of P and breaks the short cross-circuit, and the current passes through the winding-magnet and it comes again into operation. The arrangement of these circuits may be seen at Fig. 3.

P represents the spring, and Y the connection with the body of the instrument through the wheel U. When P comes into contact with Q, Fig. 1, then the circuit at P Q, Fig. 3, is closed, and the current goes from Z to X, from X to Y, from Y direct to V, and thence to N, excluding A. When the circuit at P Q is broken, the current goes from Z to X, from X to Y, from Y to A, from A to V, and thence to N, including A.

The red dotted line, Fig. 1, represents the course pursued by the current through the frame-work, body of the instrument, and the spring M, as above described, when the points P and Q come into contact, and the full red line shows its course through the wires when A is included.

I have described my improvement as applied in connection only with a spring as the motive power of the register. It can, however, be applied in connection with a weight as the motive power, though not so conveniently. In that case the machinery of the second part only would have to be modified slightly.

The arrangement of mechanism of the second part of my improvement may be variously modified without changing the principle or feature of its action—as, for example, if the motive power of the register be a spring, an arm may be made to project from one of the leaves of the spring, and as the spring is wound up this little arm will approach toward the shaft, and as the spring unwinds it will recede from the shaft. This arm may be thus made to come

into contact and out of contact with an insulated brass ring, and thus make and break the small circuit described above as cutting off the winding-magnet; or, if the register be impelled by weights, then, when the weight reaches a certain point, it can make a contact which shall have a similar effect.

Instead of employing the local battery of the register-magnet, a separate local battery may be employed to operate the winding-magnet. Then the ordinary winding-magnet's circuit would be operated by the receiving-magnet in the same manner as described above, the regulating arrangement being then applied simply to break and close the circuit of the winding-magnet.

I do not desire to claim the application of the click and ratchet-wheel operated by an electro-magnet vibrating a lever to cause rotation and obtain power; but

What I do desire to claim, and secure by Letters Patent, is—

Regulating the current through the coil of the electro-magnet of the self-winding apparatus by means of the relative motion of the spring-shaft and spring-box, so that when the spring has been wound up to a certain point that current shall be cut off and the self-winding apparatus cease to act.

JAMES J. CLARK.

Witnesses:

JNO. EYN SHAW,
STEPHEN F. SIMMONS.