

S. W. FISH.  
 LOCKING MECHANISM FOR SAFES OR VAULTS.  
 APPLICATION FILED JULY 23, 1909.

997,789.

Patented July 11, 1911.

2 SHEETS—SHEET 1.

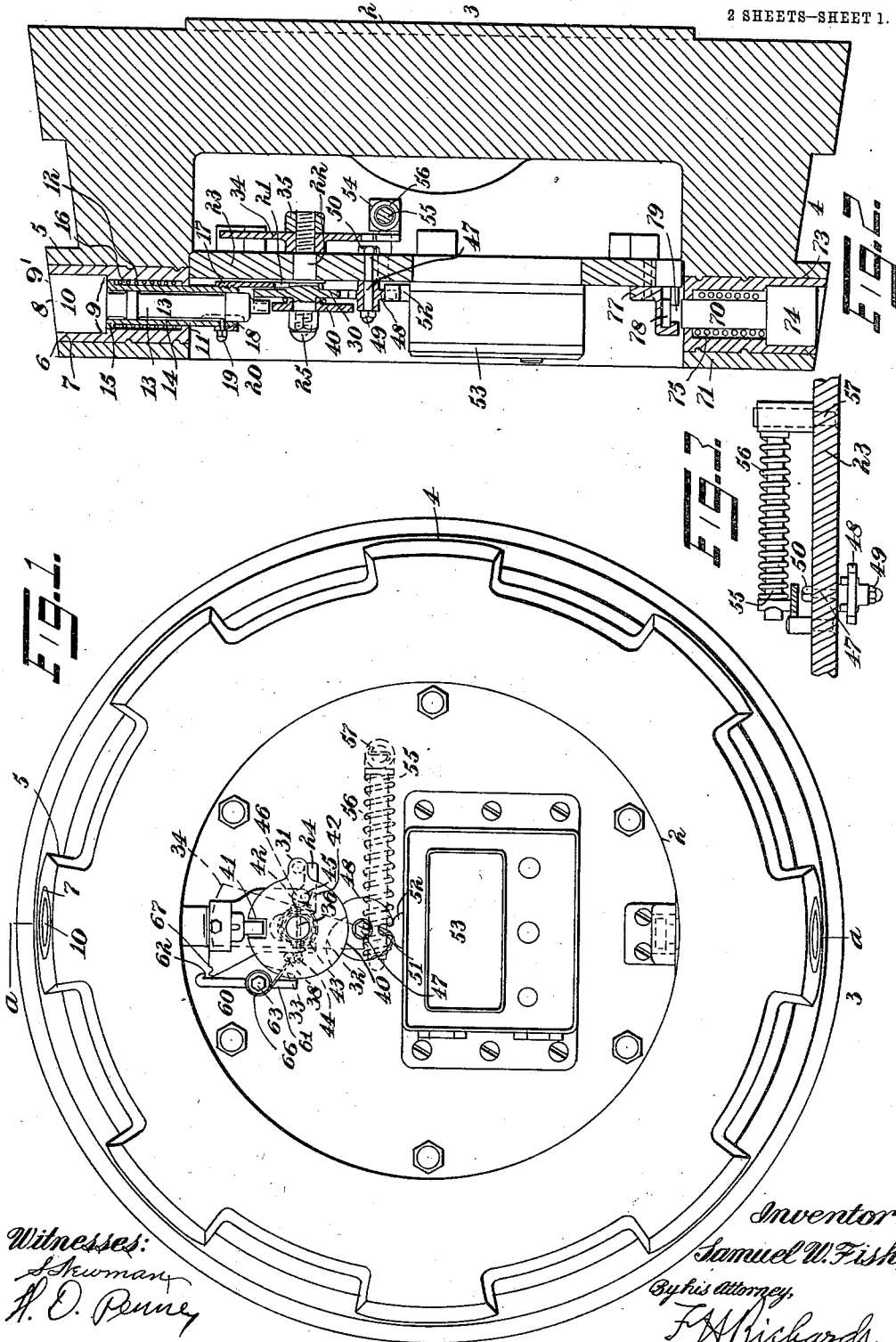

Witnesses:  
 Skuman  
 H. O. Penney

Inventor:  
 Samuel W. Fish,  
 By his attorney,  
 F. A. Richards.

S. W. FISH.  
 LOCKING MECHANISM FOR SAFES OR VAULTS.  
 APPLICATION FILED JULY 23, 1909.

997,789.

Patented July 11, 1911.

2 SHEETS—SHEET 2.

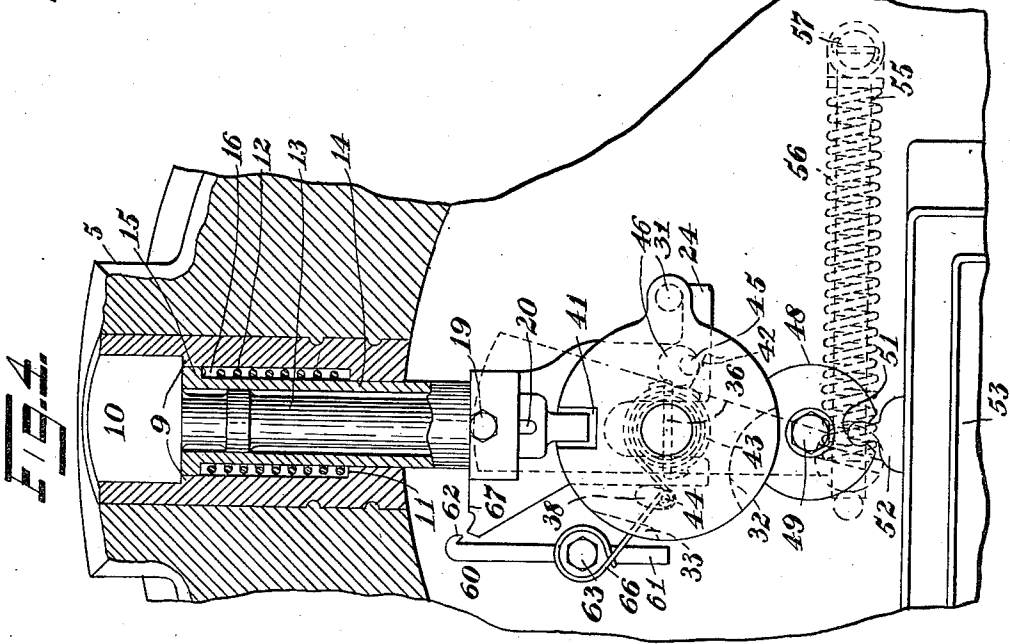
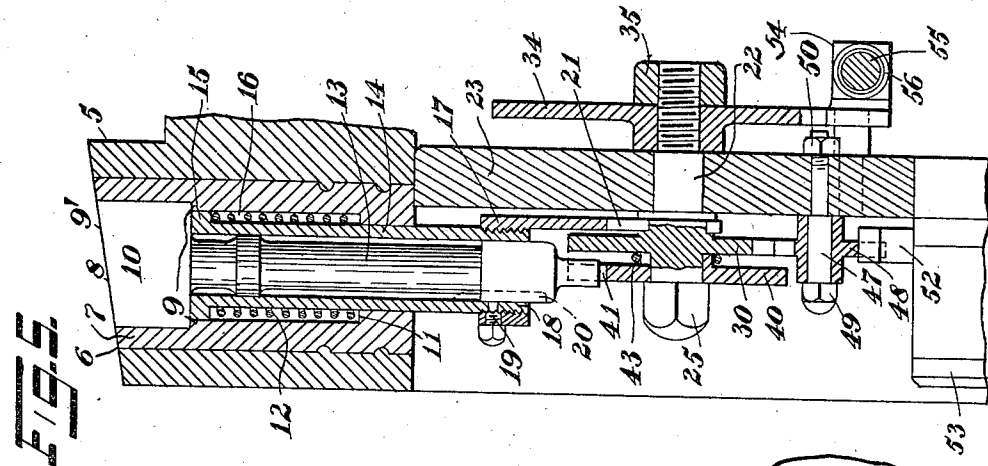
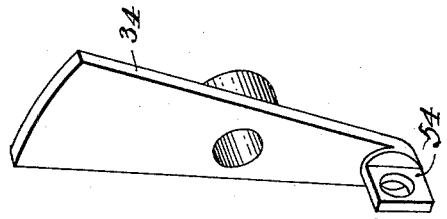

FIG. 4.

FIG. 5.

FIG. 6.



Witnesses:  
*Skinner*  
*H. J. Penney*

Inventor:  
*Samuel W. Fish,*  
 By his Attorney, *F. A. Richards.*

# UNITED STATES PATENT OFFICE.

SAMUEL W. FISH, OF PLAINFIELD, NEW JERSEY, ASSIGNOR TO TAYLOR IRON & STEEL COMPANY, A CORPORATION OF NEW JERSEY.

## LOCKING MECHANISM FOR SAFES OR VAULTS.

997,789.

Specification of Letters Patent. Patented July 11, 1911.

Application filed July 23, 1909. Serial No. 509,159.

*To all whom it may concern:*

Be it known that I, SAMUEL W. FISH, a citizen of the United States, residing in Plainfield, in the county of Union and State of New Jersey, have invented certain new and useful Improvements in Locking Mechanism for Safes or Vaults, of which the following is a specification.

The present improvement relates to locking means for doors of safes or vaults, and especially for rotary doors usually held in the jambs by means of lugs.

The object of the invention is to provide an improved means for locking a bayonet joint safe door against rotation and so organized that the locking bolt will be securely held in its locked position should the entire mechanism of the door be detached from the door, and is in part an improvement upon the locking mechanism shown and described in my co-pending application, Serial No. 531,906, filed December 7, 1909.

A further object of the invention is the provision of an improved bolt locking means which is self-locking at the proper time to prevent the door from being rotated when the cooperating lugs of the body and door are in engagement, and which bolt locking means will be automatically operated independently of any time-lock mechanism which may be used and securely hold the door against rotation, and which cannot be detached from the door by explosive charges or otherwise when the door is closed in the safe body, the time-lock mechanism acting in the present instance simply as a catch tripping means whereby the bolt retracting means is released, the time lock being thus permitted to perform the function for which it is particularly designed.

A further object of the invention is the provision of an improved door locking bolt which is not only operated by means so located as to be protected from external attacks, but which locking is dogged and unlocked through the medium of automatic locking means controlled by time-lock mechanism.

In the drawings accompanying and forming part of this specification, Figure 1 is a rear view of the bayonet joint door provided with this improved locking means; Fig. 2 is a cross-sectional view taken in line *a-a* Fig. 1; Fig. 3 is a detail sectional view of the automatic means for retracting the locking

bolt; Figs. 4 and 5 are partly sectional views showing the details of the locking devices on a larger scale; and Fig. 6 is a perspective view of the balanced lever.

Similar characters of reference indicate corresponding parts throughout the figures of the drawings.

In the application hereinbefore referred to it was stated that in bayonet joint safes, that is safes provided with locking lugs for holding the door in its jamb, some means has to be provided for preventing the rotation of the door in order to release the door, and various means of this kind have been provided, many such comprising one or more bolts controlled by time-lock mechanism. Frequently this locking bolt mechanism has been controlled by an automatic, but the bolt is connected therewith and is entirely controlled thereby to shoot the bolt into its locking position.

In the present improvement a form of automatic is used, but not for the purpose of shifting or protracting the bolt, merely for the purpose of permitting that bolt to be retracted, the present construction being such that the bolt is self-locking, the automatic mechanism being used, as stated, merely to insure the dogging and retraction of the bolt and not its projection, and the time-lock mechanism being used merely for the purpose of tripping the automatic.

The door 2, which may be of any suitable construction, usually of an integral structure, is shown in the present instance as comprising a body 3 and a rearwardly extending flange 4 having a series of locking lugs 5. In one of these lugs 5, shown as the uppermost lug when the door is in its locked position, an opening 6 is provided for the reception of an insert 7 of machineable metal, this being desirable when the door is made of unmachineable metal. This insert 7 is securely seated within the opening in the lug and is provided with a bolt opening 8 having a shoulder 9, the object of this shoulder being to prevent the locking bolt from being forced inward within the door when the door is closed, by means of an external attack with explosives or otherwise. This insert is also provided adjacent to its lower end with an annular step or shoulder 11, which forms a base for the bolt operating or locking spring 12.

The bolt 9' comprises a head 10 which in

its unlocked position engages the upper shoulder 9 and is provided with a shank 13 running through a sleeve 14, the upper end of which sleeve has a flange 15 between 5 which and the shoulder 11 at the lower end of the insert 7 a spring receiving chamber 16 for the spring 12 is formed. The flange 15 of the sleeve operates to compress the spring at the proper time to permit the retraction of the bolt. Attached to the inner 10 end of the sleeve 14 is a sleeve guide 17. This guide is attached to the sleeve by means of a threaded lug 18, which is provided with a locking screw 19 extending there- 15 through and through the sleeve and projecting into a slot 20 of the bolt, thus preventing turning of the sleeve and of the bolt independently of each other. This locking screw also prevents the bolt from being withdrawn 20 when the door is open. This sleeve guide 17 is slotted at its inner end, as at 21, to straddle the hub of the bolt retracting or driving member 30 fixedly secured to or 25 formed as a part of a projection or stud 22 passing through the back plate 23 located within the flange of the door in any suitable manner. Thus the sleeve guide is prevented from turning, so that the sleeve of such guide and the locking bolt are maintained in 30 proper alinement. Laterally extending from this sleeve guide is a projection or arm 24.

Mounted in front of the bolt retracting or driving member 30 is a bolt dogging member 40, being held in position on the stud 22 by a nut 25. The bolt retracting or driving member 30 is provided with a projection 31 in position to contact with the sleeve guide arm 24 at a predetermined period. This bolt retracting member is also provided 40 with a recess in the form of a cam surface 33 for controlling the bolt tripping or snubbing mechanism, and is also provided with a recess 32 for the catch hereinafter described to enter at a predetermined time. 45 The stud or projection 22 passing through the back plate carries a balanced lever 34 secured to the stud 22 by a nut 35 and pin not shown.

The dogging member 40 is fitted to turn 50 freely on the stud 22 and, like the bolt retracting member, is in the form of a disk. This dogging member is provided with a recess 41 for the reception of the lower end of the door locking bolt when the latter is 55 in its unlocked position. Attached to the hub of the dogging member 40 is a suitable spring 43, the other end being secured to a pin 44 carried by the back plate and projecting into an elongated opening 38 of the bolt retracting member 30. The object of this 60 spring is to maintain the edge of the recess 41 for the reception of the locking bolt against the lower end of the locking bolt when the latter is unlocked and to rotate 65 the dogging disk into position under the

lower end of the locking bolt when the bolt is protracted or in its locked position, thereby to dog the locking bolt securely until the dogging member or disk is withdrawn in the manner hereinafter described. The dog- 70 ging member 40 is also provided with a projection 42 on the side thereof adjacent to the driving member 30, and this projection is in contact with a pin 45 carried by the sleeve guide 17, this organization not being 75 interfered with by reason of the fact that the driving member 30 has an enlarged opening 46.

Mounted on a stud 47 below the driving member 30 and dogging member 40 is the 80 catch 48 held in place by a nut 49. The stud 47 passes through the back plate, being secured thereto by a nut 50. This catch 48 has a notch or recess 51 in its periphery to receive the time-lock lever 52 carried by a 85 suitable time lock 53, and is in the form of a disk with a part of its periphery cut away so as not to interfere with the rotation of the driving member 30, this cut away portion being shown as corresponding in 90 shape to the recess 32 of the member 30. The catch is mounted to turn freely on the stud 47. The balanced lever 34 mounted on the stud 22 is provided with suitable means, 95 as 54, for connecting the retracting spring guide 55 with this balanced lever and for guiding it and also for receiving the thrust of the retracting spring 56. This retracting spring guide 55 is pivotally connected to a 100 stud 57 fastened to the back plate. In order, however, to prevent the locking bolt from being shot out prematurely, as for instance when the door is open and the time lock is being wound, it is necessary to provide a tripping or snubbing mechanism 60, which 105 in the present instance comprises a pair of members, one an arm 61 and the other a catch 62 mounted on a stud 63 secured to the back plate. The adjacent hubs of the arm and catch are clutch-faced, that is to 110 say, they are formed as clutch members. Around one hub is located a spring 66, the free end of which is attached to the pin 44 hereinbefore mentioned. This snubbing mechanism is substantially similar to that 115 shown in my prior application hereinbefore referred to, and therefore further description thereof is deemed unnecessary.

The mechanism operates in the following 120 manner. In setting the mechanism for locking the door, the door locking bolt being shown in its unlocked position, with the bolt protracting spring 12 compressed by reason of the engagement of the projection 31 with 125 the extension 24 of the driving member 30, such engagement being maintained by the expansion of the retracting spring 56, since the expansion of this spring 56 operates through the balanced lever and its stud 22 to rotate the driving member 30 into such 130

position as to bring the projection 31 into engagement with the extension 24 of the sleeve guide and push the latter down, the retracting spring being stronger than the bolt protracting spring 12, the time lock is first wound for a given number of hours, during which operation no changes in position of the parts occur. By means of a crank or wrench applied to nut 25 which secures the dogging member on the stud 22 the driving member 30 is turned counterclockwise, thereby shifting the balanced lever and compressing the bolt retracting spring 56, the driving member 30 being turned until the convex face of catch 48 enters the recess 32 thereof. This catch 48 is under the control and is driven by the time-lock lever 52, which in turn is operated by the usual spring within the time lock, not shown, which spring also forces the time-lock bar to locked position. Thus, as the retracting spring 56 is compressed and locked in this compressed position by the catch 48 it carries the projection 31 away from the extension 24 of the sleeve guide to permit the spring 12 to protract the locking bolt, this, however, being prevented at this time, and until the door is closed, by the snubbing mechanism hereinbefore described, the catch 62 thereof engaging the sleeve guide and still holding the locking bolt in its retracted position against the action of its spring 12. At this time the dogging member 40 has its recess 41 in position to receive the inner end of the locking bolt, the spring 43 around the hub of this dogging member being at this time under compression. The door is then ready to be closed.

In closing the door into its jamb, the locking bolt 9', which, as will be observed, is provided with an inclined or beveled end, projects slightly above the door joint, and consequently will strike the jamb of the body when closing, and thereupon, owing to its inclined surface, be forced into the bolt receiving opening of the door as far as possible, thus forcing in the sleeve guide to a sufficient extent to carry the part 67 thereof away from the catch 62 of the snubbing mechanism, whereupon the spring 66 of the snubbing mechanism will immediately throw the lower end of the arm 61 into the recess 33 and consequently the catch 62 away from the cooperating portion 67 of the sleeve guide 17, so that when the door is revolved to its proper locked position and the bolt 9' is thus brought opposite the bolt hole in the jamb of the body its locking spring will then immediately and automatically force the locking bolt 9' into its bolt hole in the jamb and thus lock the door against rotation, this action of the bolt being entirely effected by the spring 12 without any automatic or other motor mechanism for protracting the bolt. It will also be observed

that this spring 12, which constitutes the operating means for protracting the bolt and holding it in its jamb, is entirely concealed within the flange or lug of the door and thereby protected from external attack. As the bolt 9' assumes its locking position to prevent rotary movement of the door, the dogging member 40 is, by means of its spring 43, rotated on the stud 22 to bring the periphery of such dogging member under the lower end of the bolt and thereby dog the bolt securely and prevent it from being retracted even should the spring 12 be compressed prematurely. The rotation of this dogging member 40 by its spring is stopped by the contact of the projection 42 thereof with the pin 45 on the sleeve guide. The retraction of the bolt 9' is accomplished in a way by gravity, but such retraction is under the control of the spring 56.

When the time lock runs down it forces the time-lock lever 52 to its unlocked position. This time-lock lever forces the catch 48 out of the notch or recess 32 of the driving member 30, and thereby releases the driving member at the time the time lock movement arrives at zero. This driving disk 30, on being released by its catch 48, is immediately forced by the spring 56, which has been under compression, to its unlocked position. In other words, it immediately rotates the driving member 30 clockwise and thereby causes its projection 31 to, through the medium of the arm or extension 24 of the sleeve guide, force down such sleeve guide and compress the spring 12, thereby permitting the bolt 9' to fall by gravity into its unlocked position as soon as the dogging member 40 releases the inner end of the bolt, this being effected on the return of the sleeve guide to its normal position in the manner just set forth, through the medium of the pin 45 thereof engaging the projection 42 of the dogging member and thus rotating it against the action of the spring thereof located on its hub. At this time the snubbing mechanism acts to hold the main bolt 9' in its unlocked position to permit the resetting of the time-lock.

From the foregoing it will be seen that the protraction of the bolt 9' is obtained through the medium of a spring entirely independent of an automatic or a time-lock mechanism, and that the retraction thereof is obtained by gravity when the same is undogged through the medium of a spring or automatic, the time lock being utilized simply to operate a catch and therefore merely controls the period at which the parts may operate, so that if the entire mechanism, with its back plate, were blown into the safe the main bolt would still remain in its protracted and locking position by reason of the expansion of its spring 12. In the present improvement I also provide an aux-

iliary bolt locking mechanism for assisting in locking the door should the back plate and the mechanism carried thereby be blown into the safe. In the present instance this comprises a bolt 70, somewhat similar to that hereinbefore described, working in a machineable metal insert 71 securely fastened within an opening 73 of a lug located at the underside of the door. The bolt is provided with a head 74 between which and the inner wall of the insert is located a protracting spring 75 for protracting the bolt at the proper time. For holding this spring under compression and the bolt within its bolt opening I have provided a member or bracket 77 bolted to the back plate. This member fits over the inner end of the bolt, which is provided with an enlarged portion 78 connected to the bolt shank proper by a portion or neck 79 of smaller diameter than the enlarged portion 78. This bracket is slotted and chambered for the reception respectively of the neck 79 and enlarged portion 78 of the bolt and is so formed that should the back plate be blown inwardly with this bracket attached thereto it will release the auxiliary bolt and permit its spring to protract it into the opening in the jamb and thus provide an additional locking means for the door.

I claim as my invention:

1. The combination with a safe or vault door having a bolt opening therein, of a bolt working in said opening, bolt operating means wholly located within said opening for automatically shifting the bolt at a predetermined period, spring actuated means effective to permit the retraction of the bolt, and time-lock mechanism for controlling the action of said spring actuated means.

2. The combination with a safe or vault door having a bolt opening therein, of a bolt working in said opening, bolt operating means located in said opening for automatically shifting the bolt at a predetermined period and comprising a spring, spring actuated means effective to permit the retraction of the bolt, and time-lock mechanism for controlling the operation of said spring actuated means.

3. The combination with a safe or vault door having a bolt opening therein, of a bolt working in said opening, bolt operating means located in said opening for automatically shifting the bolt at a predetermined period and comprising a spring encircling the bolt, spring actuated means effective to permit the retraction of said bolt, and time-lock mechanism for controlling the operation of said spring actuated means.

4. The combination with a safe or vault door having a bolt opening therein, of a bolt working in said opening, a compressible spring effective on its expansion to shift the

bolt, and spring actuated means effective to compress said spring.

5. The combination with a safe or vault door having a bolt opening therein, of a bolt working in said opening, a spring effective to shift the bolt, spring actuated means effective to overcome the tension of said spring, and time-lock mechanism for controlling the operation of said spring actuated means.

6. The combination with a safe or vault door having a bolt opening therein, of a bolt working in said opening, a spring located in said opening and encircling the bolt for protracting it, and spring actuated means effective to compress the spring thereby to permit the bolt to be retracted.

7. The combination with a safe or vault door having a bolt opening therein, of a bolt working in said opening, a spring located in said opening and encircling the bolt for protracting it, and spring actuated means effective to compress the spring thereby to permit the bolt to be retracted by gravity.

8. The combination with a safe or vault door having a bolt opening therein, of a bolt working in said opening, a spring encircling said bolt for protracting it, means for compressing said spring and including a balanced lever, and a spring connected thereto.

9. The combination with a safe or vault door having a bolt opening therein, of a bolt working in said opening, a spring encircling said bolt for protracting it, means for compressing said spring and including a reciprocatory device and a rotary member adapted to engage it to shift it, and a spring for shifting said rotary member.

10. The combination with a safe or vault door having a bolt opening therein, of a bolt working in said opening, a spring encircling said bolt for protracting it, means for compressing said spring and including a reciprocatory device and a rotary member adapted to engage it to shift it, a balanced lever, and a spring connected therewith for shifting said rotary member.

11. The combination with a safe or vault door having a bolt opening therein, of a bolt working in said opening, a spring located around the bolt for protracting it, a sleeve having a flange in engagement with said spring for compressing it, a sleeve guide connected thereto, a rotary member for engaging said sleeve guide to shift it thereby to compress the spring, a balanced lever connected with said rotary member, and a spring effective to shift the rotary member at a predetermined time thereby to compress the spring and permit the bolt to be retracted.

12. The combination with a safe or vault

door having a bolt opening therein, of a bolt working in said opening, a spring for protracting it, and means including a spring more powerful than the protracting spring for compressing the bolt protracting spring thereby to permit the retraction of the bolt.

13. The combination with a safe or vault door having a bolt opening therein, of a bolt working in said opening, a spring located around the bolt for protracting it, and means including a spring more powerful than the bolt protracting spring for compressing said protracting spring thereby to permit the retraction of the bolt.

14. The combination with a safe or vault door having a bolt opening therein, of a bolt working in said opening, a spring for protracting it, means including a spring more powerful than the bolt protracting spring for overcoming the tension of said protracting spring thereby to permit the retraction of the bolt, and time-lock mechanism for controlling the operation of the bolt retracting spring.

15. The combination with a safe or vault door having a bolt opening therein, of a bolt working in said opening, a spring located around the bolt for protracting it, means including a spring more powerful than the bolt protracting spring for compressing said protracting spring thereby to permit the retraction of the bolt, and time-lock mechanism for controlling the operation of the bolt retracting spring.

16. The combination with a safe or vault door having a bolt opening therein, of a bolt working in said opening, bolt operating means located in said opening for automatically shifting the bolt at a predetermined period, dogging means for the bolt when in its protracted position, a spring for releasing said dogging means, and time-lock mechanism for controlling the operation of said spring.

17. The combination with a safe or vault door having a bolt opening therein, of a bolt working in said opening, a spring concealed within the opening for protracting the bolt, dogging means for the bolt when in its protracted position, and a retracting spring more powerful than the bolt protracting spring and effective to overcome the tension of said protracting spring thereby to permit the retraction of the bolt and to also release the dogging means.

18. The combination with a safe or vault door having a bolt opening therein, of a bolt working in said opening, a spring for protracting the bolt, dogging means for the bolt when in its protracted position, a retracting spring more powerful than the bolt protracting spring and effective to compress said protracting spring thereby to permit the retraction of the bolt and to also release the dogging means, and time-lock

mechanism for controlling the operation of said retracting spring.

19. The combination with a safe or vault door having a bolt opening therein, of a bolt working in said opening, a spring located around said bolt for protracting it, dogging means for the bolt when in its protracted position, and a spring more powerful than the bolt protracting spring for compressing said protracting spring thereby to permit the retraction of the bolt.

20. The combination with a safe or vault door having a bolt opening therein, of a bolt working in said opening, a spring located around said bolt for protracting it, dogging means for the bolt when in its protracted position, a spring more powerful than the bolt protracting spring for compressing said protracting spring thereby to permit the retraction of the bolt, and time-lock mechanism for controlling the operation of said retracting spring.

21. The combination with a safe or vault door having a bolt opening therein, of a bolt working in said opening, a spring located in said opening for automatically protracting the bolt at a predetermined period, and means effective to compress said spring thereby to permit the retraction of the bolt, said means including a spring more powerful than the bolt protracting spring.

22. The combination with a safe or vault door having a bolt opening therein, of a bolt working in said opening, a spring encircling said bolt for protracting it, snubbing means for preventing the shifting of the bolt during a predetermined period, and means including a spring more powerful than the bolt protracting spring effective to permit the retraction of the bolt at a predetermined period.

23. The combination with a safe or vault door having a bolt opening therein, of a bolt working in said opening, a spring encircling said bolt for protracting it, snubbing means for preventing the shifting of the bolt during a predetermined period, means including a spring more powerful than the bolt protracting spring effective to permit the retraction of the bolt at a predetermined period, and dogging means for the bolt.

24. The combination with a safe or vault door having a bolt opening therein, of a bolt working in said opening, a spring encircling said bolt for protracting it, snubbing means for preventing the shifting of the bolt during a predetermined period, means including a spring more powerful than the bolt protracting spring effective to permit the retraction of the bolt at a predetermined period, and dogging means for the bolt, said dogging means also being operated at a predetermined period by the bolt retracting spring.

25. The combination with a safe or vault door having a bolt opening therein, of a bolt working in said opening, a spring encircling said bolt for protracting it, snubbing means for preventing the shifting of the bolt during a predetermined period, means including a spring more powerful than the bolt protracting spring effective to permit the retraction of the bolt at a predetermined period, dogging means for the bolt, said dogging means also being operated at a predetermined period by the bolt retracting spring, and time-lock mechanism for controlling the operation of the bolt retracting spring.
26. The combination with a safe or vault door having a bolt opening therein, of a bolt working in said opening, a spring encircling said bolt for protracting it, snubbing means for preventing the shifting of the bolt during a predetermined period, means including a spring more powerful than the bolt protracting spring effective to permit the retraction of the bolt at a predetermined period, dogging means for the bolt, said dogging means also being operated at a predetermined period by the bolt retracting spring, a catch for controlling the operation of the bolt retracting means, and time-lock mechanism for controlling the operation of said catch.
27. The combination with a safe or vault door having a bolt opening therein, of a bolt working in said opening, a spring for protracting said bolt, bolt retracting means including a spring more powerful than the bolt protracting spring and effective to compress said protracting spring at a predetermined period thereby to permit the bolt to be retracted, a catch for limiting the movement of said bolt retracting means, and time-lock mechanism for controlling the operation of said catch.
28. The combination with a safe or vault door having a bolt opening therein, of a bolt working in said opening, a spring for protracting the bolt, means for preventing the protraction of said bolt at a predetermined period, means for dogging the bolt when in its protracted position, and means including a spring more powerful than the bolt protracting spring and effective at a predetermined period to compress the bolt protracting spring thereby to permit the retraction of the bolt.
29. The combination with a safe or vault door having a bolt opening therein, of a bolt working in said opening, a spring for protracting the bolt, means for preventing the protraction of said bolt at a predetermined period, means for dogging the bolt when in its protracted position, and means including a spring more powerful than the bolt protracting spring and effective at a predetermined period to compress the bolt protracting spring thereby to permit the retraction of the bolt and also effective to operate the dogging means thereby to undog the bolt.
30. The combination with a safe or vault door having a bolt opening therein, of a bolt working in said opening, a spring for protracting the bolt, means for preventing the protraction of said bolt at a predetermined period, means for dogging the bolt when in its protracted position, and means including a spring more powerful than the bolt protracting spring and effective at a predetermined period to compress the bolt protracting spring thereby to permit the retraction of the bolt and also effective to operate the dogging means thereby to undog the bolt, said protracting spring being located in the bolt opening and encircling the bolt.
31. The combination with a safe or vault door having a bolt opening therein, of a bolt working in said opening, a spring concealed within said opening and encircling the bolt for protracting it, and means for compressing the spring at a predetermined time thereby to permit the retraction of the bolt, said means including a rotary member and a spring more powerful than the bolt protracting spring.
32. The combination with a safe or vault door having a bolt opening therein, of a bolt working in said opening, a spring concealed within said opening and encircling the bolt for protracting it, means for compressing the spring at a predetermined time thereby to permit the retraction of the bolt, said means including a rotary member and a spring more powerful than the bolt protracting spring, a catch for limiting the movement of said rotary member, and time-lock mechanism for controlling the operation of said catch.
33. The combination with a safe or vault door having a bolt opening therein, of a bolt working in said opening, a spring concealed within said opening and encircling the bolt for protracting it, means for compressing the spring at a predetermined time thereby to permit the retraction of the bolt, said means including a rotary member and a spring more powerful than the bolt protracting spring, a rotary catch for limiting the movement of said rotary member, and time-lock mechanism for controlling the operation of said catch.
34. The combination with a safe or vault door having a bolt opening therein, of a bolt working in said opening, a spring concealed within said opening and encircling the bolt for protracting it, means for compressing the spring at a predetermined time thereby to permit the retraction of the bolt, said means including a rotary member and a spring more powerful than the bolt protracting spring, a rotary catch for limiting

the movement of said rotary member, a time-lock mechanism for controlling the operation of said catch, and dogging means for dogging the bolt.

5 35. The combination with a safe or vault door having a bolt opening therein, of a bolt working in said opening, a spring concealed within said opening and encircling the bolt for protracting it, means for compressing the spring at a predetermined time thereby to permit the retraction of the bolt, said means including a rotary member and a spring more powerful than the bolt protracting spring, a rotary catch for limiting the movement of said rotary member, a time-lock mechanism for controlling the operation of said catch, and dogging means for dogging the bolt, said dogging means also being controlled by the bolt retracting spring.

10 36. The combination with a safe or vault door having a bolt opening therein, of a bolt working in said opening, a spring concealed within said opening and encircling the bolt for protracting it, means for compressing the spring at a predetermined time thereby to permit the retraction of the bolt, said means including a rotary member and a spring more powerful than the bolt protracting spring, a rotary catch for limiting the movement of said rotary member, a time-lock mechanism for controlling the operation of said catch, dogging means for dogging the bolt, said dogging means also being controlled by the bolt retracting spring, and snubbing mechanism for permitting the protraction of the bolt during the setting of the mechanism.

30 37. The combination with a safe or vault door having a bolt opening therein, of a bolt working in said opening, a spring concealed within said opening and encircling the bolt for protracting it, means for compressing the spring at a predetermined time thereby to permit the retraction of the bolt, said means including a rotary member and a spring more powerful than the bolt protracting spring, and a rotary dogging member for dogging the bolt.

40 38. The combination with a safe or vault door having a bolt opening therein, of a bolt working in said opening, a spring concealed within said opening and encircling the bolt for protracting it, means for compressing the spring at a predetermined time thereby to permit the retraction of the bolt, said means including a rotary member and a spring more powerful than the bolt protracting spring, and a rotary dogging member for dogging the bolt, said dogging member being operated to undog the bolt by the bolt retracting spring.

50 39. The combination with a safe or vault door having a bolt opening therein, of a bolt working in said opening, a spring for pro-

tracting said bolt, a dogging member for dogging the bolt when in its protracted position, and means including a spring more powerful than the bolt protracting spring for compressing said spring and operating the dogging means thereby to undog the bolt and permit the retraction of said bolt.

70 40. The combination with a safe or vault door having a bolt opening therein, of a bolt working in said opening, a spring for protracting said bolt, a dogging member for dogging the bolt when in its protracted position, means including a spring more powerful than the bolt protracting spring for compressing said spring and operating the dogging means thereby to undog the bolt and permit the retraction of said bolt, and time-lock mechanism for controlling the operation of said bolt retracting spring.

75 41. The combination with a safe or vault door having a bolt opening therein, of a bolt working in said opening, a spring for protracting said bolt, a dogging member for dogging the bolt when in its protracted position, means including a spring more powerful than the bolt protracting spring for compressing said spring and operating the dogging means thereby to undog the bolt and permit the retraction of said bolt, time-lock mechanism for controlling the operation of said bolt retracting spring, and snubbing mechanism effective to prevent the protraction of the bolt by its protracting spring during the setting of the mechanism.

80 42. The combination with a safe or vault door having a bolt opening therein, of a bolt working in said opening, a spring within said opening and encircling the bolt for protracting it, said bolt having a sleeve guide attached thereto, a rotary member for engaging said sleeve guide thereby to shift it and compress the bolt retracting spring, a spring actuated rotary dogging member for dogging the bolt when in its protracted position, a balanced lever connected with said rotary member, and a bolt retracting spring connected with said lever and more powerful than the bolt protracting spring for operating said rotary member thereby to compress the bolt protracting spring and permit the retraction of the bolt and also effective to operate the rotary dogging member to undog the bolt.

85 43. The combination with a safe or vault door having a bolt opening therein, of a bolt working in said opening, a spring within said opening and encircling the bolt for protracting it, said bolt having a sleeve guide attached thereto, a rotary member for engaging said sleeve guide thereby to shift it and compress the bolt retracting spring, a spring actuated rotary dogging member for dogging the bolt when in its protracted position, a balanced lever connected with said rotary member, a bolt retracting spring

connected with said lever and more powerful than the bolt protracting spring for operating said rotary member thereby to compress the bolt protracting spring and permit the retraction of the bolt and also effective to operate the rotary dogging member to undog the bolt, a rotary catch for locking the rotary member, and a time-lock mechanism for controlling the operation of said catch.

44. The combination with a safe or vault door having a bolt opening therein, of a bolt working in said opening, a spring within said opening and encircling the bolt for protracting it, said bolt having a sleeve guide attached thereto, a rotary member for engaging said sleeve guide thereby to shift it and compress the bolt retracting spring, a spring actuated rotary dogging member for dogging the bolt when in its protracted position, a balanced lever connected with said rotary member, a bolt retracting spring connected with said lever and more powerful than the bolt protracting spring for operating said rotary member thereby to compress the bolt protracting spring and permit the retraction of the bolt and also effective to operate the rotary dogging member to undog the bolt, a rotary catch for locking the rotary member, a time-lock mechanism for controlling the operation of said catch, and snubbing mechanism for preventing the protraction of the bolt during the setting of the mechanism.

45. The combination with a safe or vault door having a bolt opening therein, of a bolt working in said opening, a spring within said opening and encircling the bolt for protracting it, said bolt having a sleeve guide attached thereto, a rotary member for engaging said sleeve guide thereby to shift it and compress the bolt retracting spring, a spring actuated rotary dogging member for dogging the bolt when in its protracted position, a balanced lever connected with said rotary member, a bolt retracting spring connected with said lever and more powerful than the bolt protracting spring for operating said rotary member thereby to compress the bolt protracting spring and permit the

retraction of the bolt and also effective to operate the rotary dogging member to undog the bolt, a rotary catch for locking the rotary member, a time-lock mechanism for controlling the operation of said catch, and snubbing mechanism for preventing the protraction of the bolt during the setting of the mechanism, the operation of said snubbing mechanism being permitted at a predetermined time through the medium of the rotary member.

46. The combination with a safe or vault door having a bolt opening therein, of a bolt working in said opening, a spring within said opening for protracting said bolt, means carried by the door for compressing the spring at a predetermined period thereby to permit the retraction of the bolt by gravity and including a spring more powerful than the bolt protracting spring, and dogging means also carried by the door for dogging the bolt in its protracted position, the organization being such that the spring will maintain the bolt in its protracted position notwithstanding the separation of the spring compressing means and the dogging mechanism from the door.

47. The combination with a safe or vault door having a bolt opening therein, of a bolt working in said opening, a spring within said opening for protracting said bolt, means carried by the door for compressing the spring at a predetermined period thereby to permit the retraction of the bolt by gravity and including a spring more powerful than the bolt protracting spring, dogging means also carried by the door for dogging the bolt in its protracted position, the organization being such that the spring will maintain the bolt in its protracted position notwithstanding the separation of the spring compressing means and the dogging mechanism from the door, and auxiliary bolt mechanism operative at a predetermined period to secure the door to its seat.

SAMUEL W. FISH.

Witnesses:

H. L. STAPLES,  
H. W. WYCKOFF.