

950,932.

Patented Mar. 1, 1910.

Fig. 1.

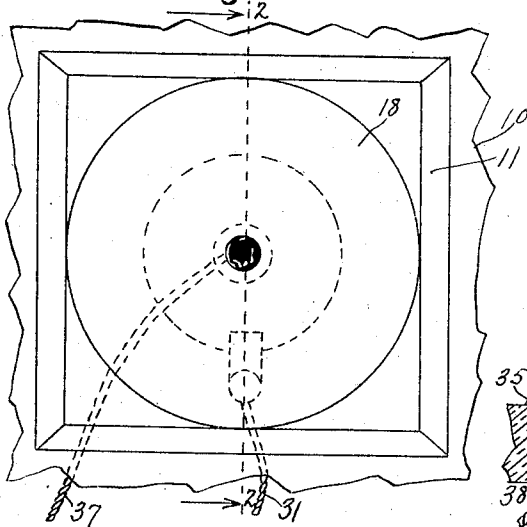

Fig. 2.

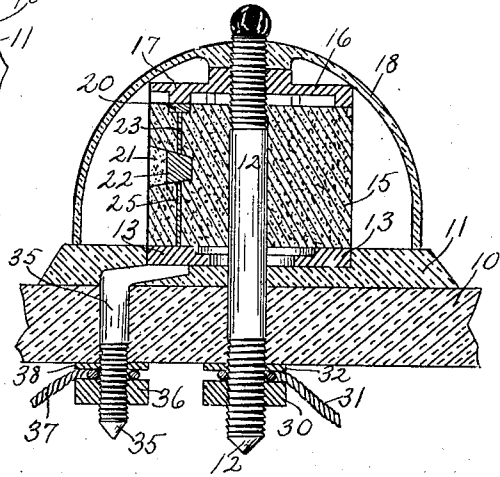

Fig. 3.

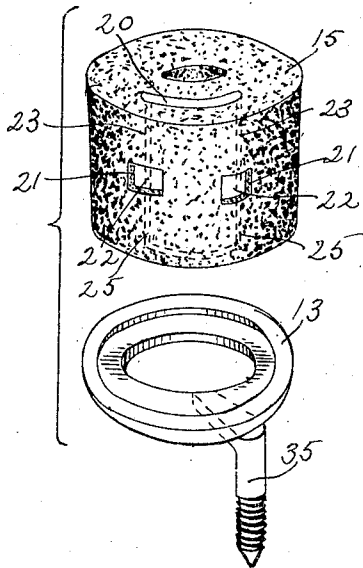
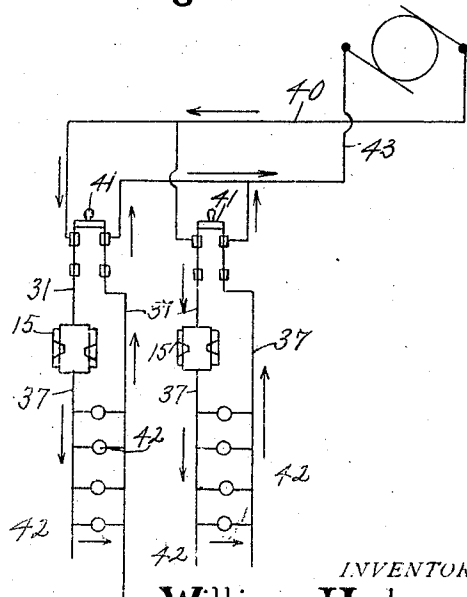

Fig. 4.



WITNESSES:  
*W. M. Gentle*  
*O. M. McLaughlin*

INVENTOR.  
**William J. Lehmann.**  
BY  
*V. H. Lockwood*  
ATTORNEY.

# UNITED STATES PATENT OFFICE.

WILLIAM J. LEHMANN, OF INDIANAPOLIS, INDIANA.

ELECTRIC FUSE.

950.932.

Specification of Letters Patent.

Patented Mar. 1, 1910.

Application filed July 20, 1908. Serial No. 444,508.

To all whom it may concern:

Be it known that I, WILLIAM J. LEHMANN, of Indianapolis, county of Marion, and State of Indiana, have invented a certain new and useful Electric Fuse; and I do hereby declare that the following is a full, clear, and exact description thereof, reference being had to the accompanying drawings, in which like numerals refer to like parts.

The object of this invention is to provide an improved construction of electrical fuse, whereby when the fuse has been burned out, a fresh fuse may be readily substituted. Hence, there is in this invention great simplicity of construction and ease of manipulation.

The full nature of this invention will be understood from the accompanying drawings and the following description and claims.

In the drawings Figure 1 is a plan view of the fuse, the base being partly broken away. Fig. 2 is a central section through the same on the line 2-2 of Fig. 1. Fig. 3 is a perspective view of some of the parts detached. Fig. 4 is a diagram of the circuits adapted to the fuse.

The fuse is mounted on the base 10 which may be made of marble or other suitable material. On it there is placed a disk or plate 11 made of porcelain or the like and both the plates 10 and 11 which practically constitute the base portion of the fuse, are apertured to receive the bolt 12. The porcelain disk 11 is centrally recessed to receive a ring plate 13 that has a central aperture of considerably greater diameter than the bolt 12 so that there will be no electrical connection between said two parts.

Upon the ring plate 13 the fuse block 15 is located and is centrally apertured for the passage of the bolt 12. Upon this fuse block there is a metal cap 16 which screws upon the threaded upper end of the bolt 12. It is centrally recessed on the under side so as to space it in the central portion thereof from the block 15, but has fuse contact projections 17 extending downwardly from the under side thereof. A semi-spherical porcelain cover 18 fits down upon the disk 11 surrounding the block 15 and cap 16. It screws upon the threaded upper end of the bolt 12.

The fuse block has one or more recesses in the top thereof for lead fillings 20 adapted to engage the downward projection 17 from

the cap 16. Each fuse block also has in its side one or more recesses 21 that taper inwardly and contain in the inner portion thereof a filling 22 of lead or other readily fusible material. The fuse block is also apertured to receive lead fillings 23. They connect the fillings 20 and 22 and 25 that extend downwardly from the fillings 22 so as to contact with the ring plate 13. Therefore, the fuse proper consists of the parts 20, 23, 22 and 25, as seen clearly in Fig. 2. When the fuse is melted the filling 22 runs down the recess 21 and breaks the circuit between the other parts.

The bolt 12 and the parts through which it projects are held in place on the base 10 by the nut 30. A wire 31 is clamped between said nut 30 and the washer 32 that lies adjacent the base 10. The current goes in through the wire 31 to the bolt 12 and thence through the cap 16 and downward extension 17 to the fuse and through it to the ring plate 13 and from that passes out over the rods 35 and 35 that extend through the base 10 and have a laterally inclined upper end that fits in the corresponding recess in the disk 11 so that the upper end of said rods will be in contact with the ring plate 13. Said rod 35 is threaded at its lower end and has a nut 36 that clamps the wire 37 in connection with the rod 35 and between the nut and the washer 38. The current passes out through said rod 35 and wire 37.

The position of the fuse in the circuit is as indicated in Fig. 4 where the current passes from the brush through the wire 40 and switch 41 to wire 31, then through the parts of the fuse, as indicated in Fig. 2, and out over the wire 37 and through the lamps 42 and back over the parallel wire 37 and wire 43 to the brush.

When the fuse is burned out, the cover 18 and cap 16 are removed and the fuse block 15 taken out and another fuse block, which is expected to be kept in stock, is put in place of the old one and the cap 16 and cover 18 replaced. This can be done very quickly and it is immaterial at what point of the ring plate 13 the lead fuses contact therewith. All that is necessary is to screw the parts down tightly and the device will operate without adjustment.

By "base portion" in the claims is meant the portion 10 and 11 or any arrangement of a part or parts on which the ring plate 13

may bear and through which the bolt 12 may pass.

What I claim as my invention and desire to secure by Letters Patent is:

5 1. An electrical fuse including a fuse block formed of non-fusible material having a recess in the side thereof, fusible material extending through said fuse block and recess, means for passing the current through  
10 said fusible material, whereby when said material is fused the portion in said recess will flow out and break the circuit.

2. An electrical fuse including a fuse block formed of non-fusible material having  
15 a recess in the side thereof that tapers inwardly and apertures leading from said recess to the top and bottom of the block, fusible material extending through said recess and apertures, and means for passing  
20 the current through said fusible material, whereby when said material is fused the portion in said recess will flow out and break the circuit.

3. An electrical fuse including a fuse  
25 block formed of non-fusible material having a recess in the side thereof that tapers inwardly and apertures leading from said recess to the top and bottom of the block, fusible material extending through said recess  
30 and apertures, electrical contacting plates on the top and bottom of said fuse block, and means for clamping the parts together so that there will be electrical connection between the fusible material in said fuse block  
35 and said plates regardless of the position to

which said fuse block may turn while being put in place.

4. An electrical fuse including a fuse block formed of non-fusible material having  
40 a recess in the side thereof that tapers inwardly and apertures leading from said recess to the top and bottom of the block, fusible material extending through said recess and apertures, electrical contacting plates on the top and bottom of said fuse block, a  
45 threaded bolt extending through said parts for clamping them together, and a cover removably secured to said bolt and extending over said parts whereby the parts may be readily removed for replacing the fuse block.  
50

5. An electrical fuse including a base portion, a threaded rod mounted therein to which an electrical conductor may be attached, a ring plate on said base portion and  
55 surrounding said bolt but out of contact therewith, a non-conducting fuse block on said bolt against said ring plate with a fuse therein in contact with said ring plate, a metal cap that screws on said bolt and  
60 against said fuse block, and a rod mounted in said base portion in contact with said ring plate and to which an electrical conductor may be attached, substantially as set forth.

In witness whereof, I have hereunto affixed  
65 my signature in the presence of the witnesses herein named.

WILLIAM J. LEHMANN.

Witnesses:

O. M. GREENER;

W. H. LOCKWOOD.