



- (51) **International Patent Classification:**
G02B 21/33 (2006.01) *G02B 21/02* (2006.01)
- (21) **International Application Number:**
PCT/EP2018/068833
- (22) **International Filing Date:**
11 July 2018 (11.07.2018)
- (25) **Filing Language:** English
- (26) **Publication Language:** English
- (30) **Priority Data:**
17181589.7 17 July 2017 (17.07.2017) EP
17181595.4 17 July 2017 (17.07.2017) EP
- (71) **Applicant:** NOVARTIS AG [CH/CH]; Lichtstrasse 35, 4056 Basel (CH).
- (72) **Inventors:** RAUSCH, Martin; Novartis Pharma AG, Postfach, 4002 Basel (CH). STEINMANN, Martin; Novartis Pharma AG, Postfach, 4002 Basel (CH). BRECHBÜHL, Tobias; Novartis Pharma AG, Postfach, 4002 Basel (CH).
- (81) **Designated States** (*unless otherwise indicated, for every kind of national protection available*): AE, AG, AL, AM, AO, AT, AU, AZ, BA, BB, BG, BH, BN, BR, BW, BY, BZ, CA, CH, CL, CN, CO, CR, CU, CZ, DE, DJ, DK, DM, DO, DZ, EC, EE, EG, ES, FI, GB, GD, GE, GH, GM, GT, HN, HR, HU, ID, IL, IN, IR, IS, JO, JP, KE, KG, KH, KN, KP, KR, KW, KZ, LA, LC, LK, LR, LS, LU, LY, MA, MD, ME, MG, MK, MN, MW, MX, MY, MZ, NA, NG, NI, NO, NZ, OM, PA, PE, PG, PH, PL, PT, QA, RO, RS, RU, RW, SA, SC, SD, SE, SG, SK, SL, SM, ST, SV, SY, TH, TJ, TM, TN, TR, TT, TZ, UA, UG, US, UZ, VC, VN, ZA, ZM, ZW.
- (84) **Designated States** (*unless otherwise indicated, for every kind of regional protection available*): ARIPO (BW, GH, GM, KE, LR, LS, MW, MZ, NA, RW, SD, SL, ST, SZ, TZ, UG, ZM, ZW), Eurasian (AM, AZ, BY, KG, KZ, RU, TJ, TM), European (AL, AT, BE, BG, CH, CY, CZ, DE, DK, EE, ES, FI, FR, GB, GR, HR, HU, IE, IS, IT, LT, LU, LV,

(54) **Title:** IMMERSION BRIDGE FOR A MICROSCOPE, MICROSCOPE, AND METHOD OF MICROSCOPICALLY IMAGING A SAMPLE

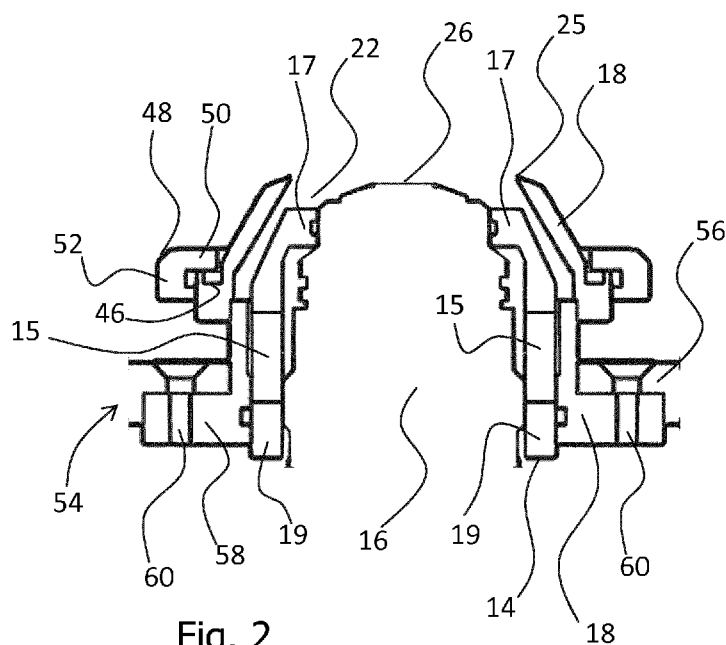

Fig. 2

(57) **Abstract:** The present invention concerns an immersion bridge (10) for a microscope (12), comprising an inner collar (14) adapted to be mounted to an objective (16) of the microscope (12), and an outer collar (18) surrounding at least a section of the inner collar (14) and being in contact with the inner collar (14) such that the inner collar (14) and the outer collar (18) form a reservoir (22) for an immersion fluid (23), wherein the inner collar (14) comprises a deformable part (15) which is adapted to be deformed such that a length of the inner collar (14) in an axial direction of the objective (12) is changed, and the outer collar (18) extends in the axial direction beyond a distal end (24) of the inner collar (14). Furthermore, the invention concerns a microscope having such an immersion bridge, and a method of microscopically imaging a sample by such a microscope.



MC, MK, MT, NL, NO, PL, PT, RO, RS, SE, SI, SK, SM,
TR), OAPI (BF, BJ, CF, CG, CI, CM, GA, GN, GQ, GW,
KM, ML, MR, NE, SN, TD, TG).

Published:

- *with international search report (Art. 21(3))*
- *in black and white; the international application as filed contained color or greyscale and is available for download from PATENTSCOPE*

Immersion bridge for a microscope, microscope, and
method of microscopically imaging a sample

Background and Field of the Invention

5 The present invention relates to an immersion bridge, a microscope having such an immersion bridge, and a method of microscopically imaging a sample by such a microscope.

10 Three-dimensional (3D) fluorescence microscopy plays a potent role for investigating cellular processes in basic research and drug discovery. Three dimensional images of cells, 3D cell cultures and organ explants can be obtained with different microscopy setups such as laser scanning microscopy (LSM) including spinning disk microscopy, confocal microscopy, multi-photon-microscopy or camera based acquisition methods such as single-plane-illumination microscopy (SPIM). In order to
15 image cells under multiple conditions over time, cells are grown in micro-well plates that usually contain between 8 and 1536 chambers. Because of the straightforward technical implementation, LSM is almost exclusively used for imaging of those plates.

20 For imaging of cells at high spatial resolution, low photobleaching and low phototoxicity, it is important to use microscopy lenses with a high numerical aperture (NA). Physically, the parameter NA provides a measure of how much of the emitted light can be collected from the object. High NA's can be achieved by optimizing the optical design of the objective and the use of an immersion fluid. The immersion fluid is dispensed between the front-lens of the objective and the bottom of the plate. Ideally,
25 it has the same refractive index as the sample and fluid surrounding the sample in the multi-well plate. The layer of immersion fluid between lens and plate needs to be maintained over time even if the plate is moved around and the fluid layer might be smeared or dried out.

30 US 2007/0291360 A1 discloses an objective with a short, sub-millimeter working distance. However, for imaging of 3D cell cultures or organ explants, objectives with a long working distance are used. The working distance of these objectives can range from 2 to 8 mm, which suggests that surface tension is by far not sufficient to create a stable layer of immersion fluid between the front-lens and the plate.

35

Description of the Invention

The present invention relates to an immersion bridge which allows for imaging a sample three-dimensionally over a wide, e.g., several millimeter, axial range, in particular, using long working distance lenses. Furthermore, the invention relates to a microscope having such an immersion bridge, and a method of microscopically imaging a sample by such a microscope.

Accordingly the present invention provides an immersion bridge for a microscope, comprising:

- an inner collar adapted to be mounted to an objective of the microscope, and
- an outer collar surrounding at least a section of the inner collar and being in contact with the inner collar such that the inner collar and the outer collar form a reservoir for an immersion fluid, wherein
- the inner collar comprises a deformable part which is adapted to be deformed such that a length of the inner collar in an axial direction (Z) of the objective is changed, and
- the outer collar extends in the axial direction beyond a distal end of the inner collar.

The present invention further provides a microscope comprising the immersion bridge of the invention and an objective to which the inner collar is mounted.

The present invention also provides a method of microscopically imaging a sample, comprising the steps of providing a microscope of the invention and deforming the deformable part of the inner collar such as to change the length of the inner collar in the axial direction (Z) of the objective, and thereby changing a distance between the objective and the sample.

The immersion bridge is provided for a microscope, which may be a fluorescence microscope, a wide-field microscope or a laser-scanning microscope.

The immersion bridge comprises an inner collar and an outer collar. The inner collar is adapted to be mounted, e.g., fixed, directly or indirectly to an objective of the microscope. The outer collar surrounds at least a section of the inner collar, e.g., the entire inner collar, and is at least in sections in contact with the inner collar such that the inner collar and the outer collar form a reservoir for an immersion fluid.

Furthermore, the inner collar comprises a deformable part which is adapted to be deformed such that a length of the inner collar in the axial direction of the objective is changed. Moreover, the outer collar extends in the axial direction beyond a distal end of the inner collar.

5

The present invention provides the advantage that immersion fluid is maintained between the objective and the sample to be investigated while the objective is being displaced in the axial direction, in particular, over several millimeters. Thus, the sample can be imaged at high resolution three-dimensionally by using an immersion objective with large working distance. In consequence, 3D cell cultures and excised organs extending over a plurality of millimeters in the axial direction can be accurately investigated by optical microscopy. Moreover, since immersion fluid is reliably kept between the front lens of the objective and the sample when the objective is displaced in the axial direction, the sample can be automatically, and thus faster, scanned in three orthogonal dimensions. In addition, since the length of the inner collar can be modified by deforming the deformable part, a relative movement between the objective and a part of the inner collar contacting the objective can be prevented, so that the objective can be displaced more precisely along the optical axis. Particularly, this configuration reduces the probability that a stick and slip phenomenon occurs at the contact between the inner collar and the outer collar. Thus, the objective can be more accurately and reliably displaced in the axial direction.

10

15

20

25

30

35

Since the position of the front lens of the objective in the axial direction can be more freely adjusted over several millimeters, while preventing that the immersion fluid rinses off, even a sample substantially extending in the axial direction over several millimeters, such as a 3D cell culture, can be accurately imaged. Not only when the front lens of the objective is in close proximity to the bottom of the imaging chamber so that surface tension maintains the immersion fluid between the front lens of the objective and the bottom of the imaging chamber, but also when the distance between the front lens and the bottom of the imaging chamber is larger than approx. 1mm, the immersion fluid is effectively kept between this lens and the bottom of the imaging chamber. In addition, when a multi-well plate is imaged, immersion is not disrupted when the stage is moved from one well to another, in particular, if the lens is moved in the axial direction.

In the context of the present disclosure, the axial direction of the objective is oriented along the optical axis of the objective and directed towards its distal end / distal end

side, i.e., the side of the objective to be arranged proximate to the sample. In other words, the distal end of the objective is, when viewed along the optical axis, the end opposite of the light source. Accordingly, the end / end side of the objective through which light coming from the light source propagates into the objective is herein
5 designated as the proximal end / proximal end side. The axial direction (i.e., Z-direction) is directed away from the front lens towards the exterior of the objective. Preferably, the axial direction is arranged vertically. Furthermore, when the inner collar is mounted to the objective and the outer collar is in contact with the inner collar, the axial direction of the inner/outer collar is the same as the axial direction of
10 the objective.

Preferably, the immersion fluid is kept in the reservoir formed by the outer collar that is in a fixed position with regard to a microscope frame and the deformable inner collar, which is mounted on the objective. The deformability of the inner collar is
15 provided such that it does not affect the agitation of z-drive of the microscope and does not deteriorate the accuracy of the system to focus on the sample in the sub-micrometer range. Thus, in an embodiment, the inner collar is mounted or fixed to the objective such that it can move together with the objective. Specifically, the position of the outer collar may be fixed with regard to a microscope frame in the axial
20 direction, for example, the upper end of the outer collar may be less than 1mm away from the bottom of a sample holder. Furthermore, the inner collar may at least partly surround or encompass the objective. Advantageously, the inner collar is configured to be put over the objective, for example, from the distal side of the objective. In particular, the inner collar may comprise an objective contacting section adapted to
25 contact the objective. In this case, advantageously, at least the objective contacting section is mounted or fixed to the objective such that the objective contacting section may be moved together with the objective, particularly, with the front lens of the objective. I.e., the objective contacting section may be adapted to move in the same direction as the objective. Thus, displacing the objective in/opposite of the axial
30 direction may cause the objective contacting section to be displaced in/opposite of the axial direction. Insofar, the inner collar may be mechanically coupled to the objective by the objective contacting section.

Furthermore, the objective contacting section may be adapted to slide on the
35 objective, such as to allow a relative movement between the objective and the objective contacting section. In this case, displacing the objective by a particular distance in the axial direction may cause the objective contacting section to be displaced by less than the particular distance in the axial direction. Alternatively, the

objective contacting section may be adapted to be fixed to the objective such as to avoid a relative movement between the objective and the objective contacting section.

5 In a preferred embodiment, the inner collar further comprises an outer collar contacting section. The outer collar contacting section may be provided at a proximal end side of the inner collar, and/or may be connected to the outer collar, e.g., such as to contact the outer collar directly or indirectly. Preferably, the inner collar is mounted or fixed to the outer collar at the proximal end of the inner collar and/or at
10 the proximal end of the outer collar. For example, the outer collar contacting section may be formed as a flange essentially extending radially outwards with respect to the optical axis of the inner collar (and of the objective). The outer collar contacting section may abut against a proximal end surface of the outer collar extending in a plane substantially perpendicular to the optical axis of the objective. Advantageously,
15 the outer collar contacting section is held, e.g., clamped, between the outer collar and a holding part provided in the proximity of the outer collar.

If the inner collar comprises the objective contacting section and the outer collar contacting section, the deformable part is preferably provided between the objective contacting section and the outer collar contacting section, for example between these
20 two sections in the axial direction. Particularly, the deformable part may connect the objective contacting section to the outer collar contacting section. Optionally, the deformable part adjoins the outer collar contacting section in the axial direction, and the objective contacting section adjoins the deformable part in the axial direction. The
25 deformable part may be formed integrally with the objective contacting section and/or the outer collar contacting section. Furthermore, the objective contacting section, the deformable part, and/or the objective contacting section may be made of the same material, for example, may be formed from one single piece of material, e.g., by molding. In a state in which the objective is mounted or fixed to the inner collar, the
30 objective may abut against or may adjoin the reservoir. In this case, for example, the inner collar may have a hole at its distal end side through which the objective may project such that the front lens of the objective limits the reservoir. Alternatively, this hole may be covered with a membrane abutting against the front lens, so that the membrane limits the reservoir.

35 The deformable part may be the entire inner collar. The deformable part may, further, be deformable radially with respect to the optical axis of the microscope. It is conceivable that the deformable part is elastically and/or plastically deformable.

Furthermore, the deformable part may be configured so that it is deformed by displacing the objective in or opposite to the axial direction. Alternatively, it is conceivable that a part of the inner collar or the entire inner collar is displaced relative to the outer collar in the axial direction of the objective while the inner collar keeps contacting the outer collar to form the reservoir.

The outer collar may, particularly, surround the objective contacting section and/or the deformable part of the inner collar and the outer collar contacting section may contact the inner collar directly or indirectly. The outer collar may have the same symmetry as the objective and/or the inner collar, e.g., may be essentially cylindrically shaped. In the present context, a cylindrical shape comprises a conical shape. Furthermore, the outer collar may at least partly surround or encompass the entire inner collar and, preferably, the objective. Any of the inner and the outer collar may have a distal portion and a proximal portion. The distal portion of the inner and/or the outer collar may be shaped like a shell of a truncated cone. Thus, the radius of the distal portion of the inner collar at its distal end may be smaller than the radius of the distal portion of the inner collar at its proximal end side or proximal end. Advantageously, the reservoir holds less immersion fluid in this case, so that it can be more quickly emptied and refilled.

When the reservoir is filled with immersion fluid, the immersion fluid level is preferably proximate to, most preferably in the axial direction at, a distal end of the outer collar. In the present context, at the distal end of the outer collar means that the immersion fluid level may, due to the surface tension of the immersion fluid, be above the distal end of the outer collar in the axial direction, in the presence and even in the absence of a sample. The immersion fluid may be or may comprise any one of water or immersion oil.

The objective of the microscope is advantageously connected to an objective stage, which is adapted to displace the objective in the axial direction of the objective. In particular, the objective (i.e., the objective lens) may be displaced (e.g., by the objective stage) from a first position to a second position in the axial direction. In the axial direction, the first position and the second position may be spaced by at least or at most 1mm, 2mm, 3mm, 5mm, 7mm, 10mm, 12mm or 15mm. When the objective is in its first position, its distance to a light source of the microscope along the optical axis of the microscope is preferably smaller than its distance to the same light source when the objective is in its second position. Accordingly, when the objective is in its

first position, its distance to the sample is preferably larger than its distance to the sample when the objective is in its second position.

In a further embodiment, the inner collar is adapted to change, i.e., modify, a volume of the reservoir when the deformable part is (being) deformed, particularly, in the axial direction. Preferably, the deformable part is adapted to be deformed between a first form and a second form in the axial direction. When the deformable part is being deformed between its first and second form, its shell or contour may change. Particularly, the width of the deformable part in the radial direction may decrease. The inner collar may have its first form when the objective is in its first position and the inner collar may have its second form when the objective is in its second position. In this case, modifying the volume of the reservoir by deforming the deformable part from its first form to its second form may occur simultaneously with modifying the volume of the reservoir by displacing the objective. Independently of whether the deformable part of the inner collar or the objective is in its first or second form/position, the distance between the light source and the distal end of the outer collar is the same. Also, independently of whether the deformable part of the inner collar or the objective is in its first or second form/position, the distance between the sample and the distal end of the outer collar is the same. Accordingly, the outer collar is fixed in the axial direction, whereas the distal end of the inner collar is adapted to be displaced in the axial direction.

Furthermore, when the deformable part of the inner collar has its first form, the distal end of inner collar is farther remote from the distal end of outer collar (and, thus, the distal end of the reservoir) than when the deformable part has its second form. Thus, when the deformable part has its first form, the volume of the reservoir is larger than when the deformable part has its second form. It is also conceivable that the inner collar may modify the volume of the reservoir when the inner collar, or at least its deformable part, is being displaced. Particularly, when the deformable part is deformed from its first form to its second form, so that the distal end of the inner collar is moved in the axial direction, the inner collar pushes immersion fluid out of the reservoir so that the volume of immersion fluid present in the reservoir is reduced. In this case, the immersion fluid may flow out of the reservoir, e.g., over the distal end of the outer collar and/or through an opening in the outer collar, in each case preferably to a below described overflow chamber. On the other hand, when the inner collar is deformed from its second form to its first form, whereby the distal end of the inner collar is moved opposite of the axial direction, the volume of the reservoir is being increased. In this case, additional immersion fluid may be introduced into the

reservoir, e.g., by means of a fluid flow generating device described below, to reach or keep the immersion fluid level at the distal end of the outer collar.

5 For imaging, the immersion fluid may be pushed through an opening at the upper end of the outer collar against the bottom of a well-plate. The volume of the reservoir depends on the position of the inner collar in the axial direction with respect to the outer collar. A constant infusion of immersion fluid into the reservoir while withdrawing access immersion fluid from the overflow chamber will account for creating a stable attachment of immersion fluid to the bottom of the well-plate while
10 the objective is moved in the axial direction.

In a further embodiment, the inner collar comprises a bellows configured to be expanded or contracted in the axial direction. Particularly, the deformable part may be or may comprise the bellows. Thus, if the inner collar comprises an objective
15 contacting section and an outer collar contacting section, the bellows may be provided between the objective contacting section and the outer collar contacting section, e.g., such as to connect the objective contacting section with the outer collar contacting section. The bellows may comprise one or more folds extending such as to encompass the objective. For example, one or more of these folds may extend
20 along a circular path when viewed in a plane transversal to the axial direction. Advantageously, the bellows is, thus, expendable in the axial direction from its first form to its second form. When the bellows has its first form, its length in the axial direction is smaller than its length in the axial direction when the bellows has its second form. This configuration enables a particularly smooth displacement of the
25 objective in or opposite of the axial direction, particularly, if the objective contacting section is fixed to the objective such as to stick to a surface of the objective when the objective is displaced in the axial or opposite of the axial direction, i.e., when the inner collar does not slide over the objective. Thus, the occurrence of a stick-and-slip phenomenon can be more effectively prevented, even if the objective is displaced
30 comparably fast. It is needless to say that the bellows, being one type of a deformable part, may have each of the herein described features of the deformable part.

The deformable part may be substantially shaped at least in sections, preferably in its
35 entirety, like a shell of a truncated cone. Substantially having the shape of a truncated cone means herein that the deformable part has at one of its axial ends a first diameter, and has at the other one of its axial ends a second diameter, the second diameter being smaller than the first diameter. Particularly, the deformable

part (e.g., the bellows) may have its first diameter at its proximal end side, and its second diameter at its distal end side. This means that the diameter of the deformable part may decrease towards the distal end of the deformable part, particularly, when the diameter is measured in a plane extending transversally to the axial direction. Accordingly, the deformable part provides improved stability against flexing in a direction perpendicular to the axial direction.

In a further alternative, a contact between the inner collar and the outer collar may be a sliding contact, i.e., the at least part of or the entire inner collar may slide on the outer collar while keeping the contact with the outer collar. The inner collar may contact the outer collar along the outer circumference of the inner collar and/or along the inner circumference of the outer collar. More particularly, the inner collar may contact the outer collar along a closed path, for example, having the shape of an ellipse, particularly, in a plane oblique, e.g. perpendicular, to the axial direction. Thus, the contact between the inner and outer collar defines a proximal end of the reservoir. In the axial direction, the reservoir may extend beyond a distal end of the inner collar and/or beyond a distal end of the objective. Accordingly, the outer collar may extend in the axial direction beyond the distal end of the inner collar and/or the objective. Preferably, the inner collar is adapted to be retracted relative to the outer collar in a direction opposite of the axial direction so that the distal end of the outer collar is offset relative to the distal end of the inner collar, e.g., by at least or at most 2mm, 4mm, 6mm, 8mm, 10mm, 12mm, 14mm or 16mm.

Moreover, the outer collar may be mounted to the microscope, to a base of the microscope and/or to a microscopy stage, particularly, such as to have a fixed distance in the axial direction to the bottom of the sample. For example, the outer collar may be adapted to be mounted at a fixed distance in the axial direction from at least a part of a sample holder of the microscope. Thus, the outer collar may comprise a fixing device configured for mounting, preferably fixing, the outer collar to the holding part provided in the proximity of the outer collar. Preferably, the fixing device is cylindrically shaped. In an embodiment, the fixing device comprises a radially extending flange, which may be mounted or fixed to the holding part by fixing means, e.g., by screws. Particularly, the holding part may extend radially with respect to the axial direction in a transversal plane. The holding part and the flange of the fixing device may overlap to be joined together, e.g., by screw/s or adhesive. Particularly, the flange of the fixing device may be positioned on a surface of the inner collar facing in the axial direction, e.g. at the outer collar contacting section, and/or a surface of the holding part facing in the axial direction. Furthermore, it is

conceivable that the flange of the fixing device is positioned on a surface of the inner collar, e.g. at the outer collar contacting section, and/or a surface of the holding part facing opposite of the axial direction. The holding part is preferably a part, such as a frame part, of the microscope. Advantageously, the holding part has a bore through which the objective extends.

Additionally, the contact between the inner collar and the outer collar may be configured to seal the reservoir, preferably along the inner circumference of the outer collar. I.e., the outer collar may comprise an inner surface, which is preferably an inner circumferential surface. The inner surface may have a recess and a sealing ring, such as an O-ring, arranged in the recess. The recess preferably has a U-shaped cross-section and/or is arranged in the proximal portion of the outer collar, optionally proximate to the proximal end of the inner collar when the inner collar is in its second position. The sealing ring may provide a sealing contact between the inner collar and the objective while permitting the axial displacement between the inner collar and outer collar.

Furthermore, the inner collar may be mounted to the objective, preferably by the objective contacting section, such as to seal at least a part of the objective against immersion fluid present in the reservoir. Thus, in an embodiment, the inner collar has an inner surface facing and contacting the objective, the inner surface advantageously being an inner circumferential surface of the inner collar. The inner surface may have a recess and a sealing ring, such as an O-ring, arranged in the recess. The recess preferably has a U-shaped cross-section and/or is arranged in the distal portion of the inner collar, optionally proximate to the distal end of the inner collar. Particularly, the recess may extend along the inner circumference of the inner collar. The sealing ring may provide a sealing contact between the inner collar and the objective. Moreover, the inner collar may comprise a wheel configured to interact with a coverslip correction device of the objective. Particularly, the wheel may be formed as a toothed wheel, and/or may extend in the axial direction and be adapted to rotate about an axis parallel to and offset from the optical axis. Thus, the wheel is preferably adapted such as to actuate, e.g. rotate, the coverslip correction device of the objective, when being itself rotated about its axis.

In a further embodiment, the deformable part is spaced apart from the outer collar. Particularly, the deformable part may be spaced apart from the outer collar, when the deformable part has its first form (i.e., shape) and/or when the deformable part has its second form (i.e., shape). Preferably, the deformable part may be spaced apart

from the outer collar in the radial direction of the objective, of the inner collar, or of the deformable part. This radial direction is substantially perpendicular to the axial direction. Additionally or alternatively, the objective contacting section may be spaced apart from the outer collar, e.g., in the radial direction of the objective, of the inner collar, or of the deformable part. This allows the deformable part to expand and contract more freely, so that the objective can be displaced more precisely in or against the axial direction. The space between the deformable part and/or the objective contacting section and the outer collar may be provided for immersion fluid, thus, may form part of the reservoir.

It has been said that the immersion bridge may comprise an overflow chamber. This chamber is preferably adapted to collect immersion fluid escaping from the reservoir when the deformable part of the inner collar is being deformed. In particular, deforming the deformable part may modify the volume of the reservoir taken by the inner collar. If the deformable part is expanded or stretched in the axial direction, the volume of the reservoir taken by the inner collar may increase. On the other hand, if the deformable part is compressed, the volume of the reservoir taken by the inner collar may decrease. When the deformable part of the inner collar is being deformed, the distal end and/or the proximal end of the inner collar may be displaced in the axial direction.

The overflow chamber may be formed on the outer surface, e.g., the outer circumferential surface, of the outer collar. Further, the overflow chamber may be arranged at the distal or at the proximal portion of the outer collar. Moreover, the overflow chamber may be formed integrally with the outer chamber. Advantageously, the overflow chamber is formed integrally with the flange, e.g., on a side of the flange facing in the axial direction. The overflow chamber may comprise a ring-shaped recess extending along the outer circumference of the outer collar. The recess may extend from a surface of the overflow chamber facing in the axial direction in a direction opposite of the axial direction. Furthermore, the recess may have a substantially U-shaped cross-section in a plane comprising the optical axis of the objective. If the overflow chamber is formed integrally with the flange, the recess may extend into the flange, so that the overflow chamber can be manufactured more easily. Thus, the flange may have a substantially L-shaped cross section in a plane comprising the optical axis of the objective. The flange of the fixing device may be spaced apart from the distal end of the outer collar by at least 5 mm. Additionally, the overflow chamber may comprise a cap having a flange covering the recess of the overflow chamber at least in sections. Furthermore, the cap may have a lower portion

abutting against a surface of the outer collar facing radially with respect to the optical axis. The cap is preferably ring-shaped and may be adapted to extend the volume of the overflow chamber to a volume larger than the volume of the recess.

5 The above mentioned fluid flow generating device of the immersion bridge has a pumping device, an inlet conduit, and a fluid source. The inlet conduit may be connected to the reservoir, i.e., fluidically connected therewith. Furthermore, the inlet conduit may be in fluidic communication with the fluid source. The pumping device may be configured to direct/cause immersion fluid to flow, preferably from the fluid
10 source, towards the reservoir, particularly, through the inlet conduit into the reservoir. E.g., the outer collar, such as in its outer cap, may have an inlet, optionally with a check valve, through which inlet the immersion fluid may enter the reservoir. The inlet may be arranged proximate to the proximal end side of the outer collar. A check valve may be arranged within the inlet conduit, the check valve being adapted to
15 prevent flow out of the reservoir through the inlet conduit. In another alternative, the pumping device may comprise a bypass around the pumping device, the inlet conduit and bypass being configured such that fluid may flow out of the reservoir through the inlet conduit and the bypass to the fluid source, when the volume of the reservoir is being reduced.

20 In an embodiment, the fluid source is or comprises the overflow chamber. Thus, the inlet conduit may communicate with the overflow chamber such that immersion fluid collected in the overflow chamber may flow out of the overflow chamber into the reservoir through the pumping device and the inlet conduit. The fluid source may
25 alternatively or additionally comprise a further, e.g. separate, immersion fluid tank. Moreover, the immersion bridge may comprise an outlet conduit in fluid communication with the fluid source. If the fluid source is the overflow chamber and the fluid source comprises a further immersion fluid tank, the outlet conduit may interconnect the overflow chamber with the further immersion tank.

30 The outer collar and/or the inner collar, preferably, the deformable part or the bellows of the inner collar, may be made at least in sections of an elastic material, such as an elastomer or a rubber, preferably, a natural rubber, latex or a silicone. Thus, the elastic modulus of any of the outer collar, the inner collar, the deformable part, and
35 the bellows may be on the order of 10 to 100 MPa. In this case, the recess in the inner collar is not necessary. Rather, the objective may tightly fit into the inner collar so that the sealing between the objective and the inner collar is obtained by location/transition fit or press fit. To obtain such sealing fit, the objective may be

pressed from the proximal end of the inner collar into the inner collar in the axial direction so that the objective radially biases the inner collar proximate to its distal end.

5 A microscope described herein comprises an immersion bridge as described above, and an objective to which the inner collar is mounted, preferably, fixed. The microscope may be a microscope of one of the types described above. Preferably, the microscope further comprises a sample holder. The inner and outer collars may be configured such that a distance, particularly, a distance in the axial direction
10 between the outer collar and at least a part of the sample holder, e.g. the entire sample holder, is fixed when the deformable part of the inner collar is being deformed.

The immersion bridge is preferably arranged such that the distance in the axial
15 direction between the sample holder and the outer collar is fixed/constant, i.e., remains the same, even when the deformable part is being deformed or when the distal end of the inner collar and/or the objective is displaced in the axial direction. Therefore, even when the distal end of the inner collar and/or the objective is being displaced axially so that the volume of the reservoir is being changed, the axial
20 distance between the outer cap and the sample is maintained constant. Accordingly, the immersion bridge is adapted for maintaining immersion fluid between the front lens of the microscope and the sample held in the sample holder.

A method of microscopically imaging a sample comprises the step of providing a
25 microscope described above. In particular, a sample may be held by the sample holder, and the reservoir may be filled with immersion fluid so that immersion fluid is present between the front lens and the sample. Moreover, the method comprises deforming the deformable part of the inner collar, preferably the entire inner collar, such as to change the length of the inner collar in the axial direction of the objective,
30 and thereby changing an axial distance between the objective and the sample. Particularly, the deforming of the deformable part may be a deforming in the axial direction of the objective. Optionally, during the deforming of the deformable part, the outer collar may remain undeformed.

35 During the deforming step, the axial distance between the sample and the outer collar is preferably maintained constant. Moreover, if the deforming step comprises deforming the part of the inner collar, at least a part of the immersion fluid may be pushed out of the reservoir, and collected in the overflow chamber. On the other

hand, if the deforming step comprises deforming the deformable part of the inner collar opposite of the axial direction, to maintain the immersion fluid level, immersion fluid may be flown into the reservoir, advantageously by the fluid flow generating device. The deforming of the deformable part may be caused by displacement of the objective by means of a linear stage. Optionally, the inner collar may slide along the outer collar in the displacing step. Subsequently to, simultaneously with, or before the displacing step, the sample may be displaced in a plane substantially perpendicular to the axial direction. Simultaneously with the above displacing step and/or with displacing the sample in the plane substantially perpendicular to the axial direction, the microscope may acquire image signals (e.g., by means one or more sensors), to generate a three-dimensional optical image. Herein, the term substantially perpendicular means that an angle between the plane and the axial direction may be in the range of 80° to 100° , preferably 85° to 95° , most preferably between 88° and 92° . Thus, the plane may extend slightly oblique with respect to a plane ideally transversal to the axial direction. The substantially perpendicular plane may be a transversal plane of the objective.

Preferred embodiments of an immersion bridge and a microscope are described in greater detail with reference to the attached schematic drawings in the following, wherein

Figure 1 shows a cross-sectional view of a microscope along the optical axis, the microscope having an immersion bridge according to an embodiment mounted therein,

Figure 2 shows a detailed cross-sectional view of the microscope of Fig. 1 along the optical axis, wherein the deformable part has a second form,

Figure 3 shows a detailed cross-sectional view of the microscope of Fig. 1 along the optical axis, wherein the deformable part has a first form,

Figure 4 shows a perspective view of the microscope of Fig. 1 from diagonally above the immersion bridge,

Figure 5 shows a perspective view of the outer collar of an immersion bridge according to a further embodiment as viewed from diagonally above,

Figure 6 shows a perspective view of the inner collar of an immersion bridge according to a further embodiment as viewed from diagonally above,

Figure 7 shows a combined partial perspective and cross-sectional view of a further microscope from diagonally above the immersion bridge, wherein the cross-sectional view is in a plane comprising the optical axis of the objective,

Figure 8 shows a partial perspective view of the microscope of Fig. 7 from diagonally above the immersion bridge,

Figure 9 shows a partial top view of the microscope of Fig. 7,

Figure 10 shows a partial side view of the microscope of Fig. 7, and

Figure 11 shows a partial cross-sectional view of the microscope of Fig. 7.

An immersion bridge 10 for a microscope 12 is shown in Figs. 1 to 4. The microscope 12 is an inverted two-photon microscope, but the immersion bridge may alternatively be utilized in other types of microscopes. The immersion bridge 10 comprises an inner collar 14 mounted, herein exemplarily fixed, to an objective 16 of the microscope 12 and an outer collar 18 surrounding a part of the inner collar 14, particularly, surrounding a deformable part 15 of the inner collar 14. The inner and outer collars 14, 18 contact each other at a contact 20 and together form a reservoir 22 for an immersion fluid 23. The reservoir 22 is limited by the outer collar 18, the inner collar 14, and the objective mounted in the inner collar 14. Alternatively, a membrane may cover the objective 16 in an area between the objective 16 and the reservoir. The objective 16 is tightly fit into the inner collar 14 so that the objective contacts the inner collar 14 proximate to a distal end 24 of the inner collar 14 at an outer circumferential surface of the objective 16.

As shown in Figs. 2 and 3, the deformable part 15 can be deformed, herein compressed and expanded, in and opposite of the axial direction Z, so that the length of the deformable part 15 in the axial direction Z is changed. Particularly, in Figs. 1 and 2, the objective 16 and a distal end 24 of the inner collar 14 are shown in their second position, wherein the objective 16 and the distal end 24 are arranged more distally than in their respective second position shown in Fig. 3, and the deformable part 15 has a second form which is more extended in the axial direction than a first

form of the deformable part 15 shown in Fig. 3. Thus, the focal region of the objective 16 is farther away from the outer collar 18 in the axial direction Z when the objective 16 and the distal end 24 of the inner collar 14 are in their second position and the deformable part has its second form than when the objective 16 and the distal end 24 of the inner collar 14 are in their first position and the deformable part has its first form. In the exemplary arrangement shown in Figs. 1 and 2, the inner collar 14 and the objective 16 are in their most distal end position, and in the exemplary arrangement shown in Fig. 3, the inner collar 14 and the objective 16 are in their most proximal end position, respectively. In both situations, i.e., when the inner collar 14 and the objective 16 are in their first and second positions and when the deformable part 15 has its first and second form, respectively, the outer collar 18 extends beyond the distal end 24 of the inner collar and the distal end 26 of the objective 16. Therefore, the reservoir 22 extends farther distally than the inner collar 14 and the objective 16 when the inner collar 14 and the objective 16 are in their first and second positions, and when the deformable part 15 has its first and second form, respectively. It is further noted that the objective 16, particularly a front lens of the objective 16, projects in the axial direction Z through an opening 28 in the inner collar 14, which opening 28 may optionally be covered by a membrane.

Proximate to the distal end 24 of the inner collar 14, the inner collar 14 has an objective contacting section 17 by which the inner collar sealingly contacts the objective 16. Exemplarily, this contact is present between an inner circumferential surface 30 of the objective contacting section 17 and an outer circumferential surface 38 of the objective 16. In particular, the inner circumferential surface 30 comprises a recess 32 in which an O-ring (not shown) is arranged press-fit between the inner circumferential surface 30 and the objective 16 to provide the contact between the objective contacting section 17 and the objective 16. The O-ring, thus, extends along an outer circumferential surface 38 of the objective 16 in a plane perpendicular to the axial direction Z. The O-ring is made of an elastic material, such as a rubber. By this configuration, a part of the outer circumferential surface of the objective 16 arranged below the O-ring is sealed against the reservoir 22, so that immersion fluid 23 present in the reservoir 22 is prevented from spilling this part of the objective 16. Alternatively, the entire inner collar 14 may be made of an elastic material, e.g., like a gasket. Thus, the objective 16 can be pressed into the inner collar 14 to deform and bias the inner collar 14 radially outwards, so that the inner collar 14 essentially clamps the objective 16. In an alternative, the recess 32 is formed in the objective 16 instead of in the inner collar 14.

The inner collar 14 further comprises an outer collar contacting section 19, at which the outer collar 18 has a recess 36, which may be formed like the recess 32. Alternatively, the recess 36 may be formed in the inner collar 14 instead of the outer collar 18. The recess 36 is arranged more proximate to the proximal end 27 of the objective 16 than the recess 32, and, particularly when the distal end 24 of the inner collar 14 and the objective 16 are in their second position and the deformable part 15 has its second form, on the level of a central portion of the objective 16 in the axial direction Z. In the recess 36, a further O-ring (not shown) is arranged, which extends between the inner circumferential surface 34 of the outer collar 18 and an outer circumferential surface 40 of the inner collar 14 such as to seal the reservoir 22. The deformable part 15 is provided between the objective contacting section 17 and the outer collar contacting section 19.

When the distal end 24 of the inner collar 14 and the objective 16 are moved between their first position shown in Fig. 3 and their second position shown in Fig. 2, or when the deformable part 15 is deformed between its first form shown in Fig. 3 and its second form shown in Fig. 2, the bottom of the reservoir 22 is at least partially moved in the axial direction Z so that the inner volume of the reservoir 22 is changed. Particularly, when the distal end 24 of the inner collar 14 and the objective 16 are moved from their first position into their second position, or when the deformable part 15 is expanded from its first form to its second form, the inner volume of the reservoir 22 is reduced, so that immersion fluid 23 present in the reservoir swaps out of the reservoir 22, e.g., over a distal end 25 of the outer collar 18. The outer collar 18 is, thus, configured such that the escaping immersion fluid 23 flows in a direction opposite of the axial direction Z along an outer circumference 42 of the outer collar 18 into an overflow chamber 46 (see Figs. 2 and 3). Accordingly, this overflow chamber 46 collects immersion fluid 23 escaping from the reservoir when the distal end of the inner collar 14 is displaced in the axial direction or when the deformable part 15 is stretched in the axial direction Z.

The overflow chamber 46 comprises a ring-shaped recess which extends circumferentially with respect to the optical axis A. The recess extends in a direction opposite of the axial direction Z from a surface of the outer collar facing in the axial direction Z. Furthermore, the overflow chamber 46 comprises a cap 48 having a flange 50 extending radially inwards with respect to the optical axis A, and partly covering the recess of the overflow chamber 46. Furthermore, the cap 48 has a lower portion 52 abutting against a radially outer circumferential surface of the outer collar.

The cap 48 comprises a recess extending radially outwards from a surface of the 48 facing radially inwards.

5 The outer collar 18 further comprises a fixing device 54 by which the outer collar 18 is mounted, herein fixed, to a holding part 56 being a stage of the microscope 12 provided in the proximity of the outer collar 18. The fixing device 54 comprises a flange 58 extending radially outwards with respect to the optical axis A, at which the outer collar 18 is mounted to the holding part 56 by fixing means 60, which are herein screws 60. Alternatively, the holding part 56 may comprise a recess at its surface
10 facing in the axial direction Z adapted to receive the flange 58. In this case, the flange 58 is preferably formed complementary to the recess.

Furthermore, the immersion bridge 10 comprises a fluid flow generating device having an inlet conduit 64, a pumping device 66 and a fluid source. The fluid source
15 may comprise the overflow chamber 46 and an additional immersion fluid tank 68. The inlet conduit 64 is connected with the fluid source and the reservoir 22, and the pumping device 66, herein a pump, is configured to cause the immersion fluid 23 to flow from the fluid source through the inlet conduit 64 into the reservoir 22. In particular, when the objective 16 or the distal end 24 of the inner collar 14 is moved in
20 the axial direction Z so that fluid escapes from the reservoir 22, this fluid flows through an outlet conduit 65 into the tank 68. On the other hand, when the objective 16 / distal end 24 of the inner collar 14 is moved in a direction opposite of the axial direction Z, the immersion bridge 10 is configured such that immersion fluid 23 is refilled to the reservoir 22 at least until the immersion fluid level reaches the distal
25 end 25 of the outer collar 18. Thus, the pumping device 66 generates a flow of immersion fluid 23 from the immersion fluid tank 68 through the inlet conduit 64 and through an inlet provided in the outer collar 18 into the reservoir 22.

30 The microscope 12 further comprises a sample holder 70 configured to hold a sample 72. In the particular example shown in Figs. 1 to 3, the sample 72 is a multi-well plate for 3D cell culture. In order to three-dimensionally image a specimen 74 provided in one of the wells, the outer collar 18 is brought to the very proximity of the bottom of the sample 72, so that the outer collar 18 just does not contact the sample
35 72. Then, the immersion fluid is flown into the reservoir 22 by the inlet conduit 64 until the reservoir 22 is filled with immersion fluid, whereby the sample 72 and the sample holder 70 are moved to their initial position by means of a motorized stage 76 adapted to displace the sample 72 and sample holder 70 in a plane transversal to the optical axis A. Furthermore, the objective 16 and the objective contacting section 17

of the inner collar 14 are brought to their initial scanning position by means of a further motorized stage 78 adapted to displace the objective 16 along the optical axis A. Subsequently, the inner collar 14 is displaced in the axial direction Z in the transversal directions X, Y to scan the specimen 74 three-dimensionally. During the scanning, a distance in the axial direction Z between the objective 16 and the sample 72 is changed after each scan in a transversal plane has been finalized.

An outer collar 18 of a further immersion bridge 10 is shown in Fig. 5. This outer collar 18 differs from the outer collar 18 shown in Figs. 1 to 4 in that the overflow chamber 46 is formed integrally with the flange 58 of the fixing device 54, and a cap 48 is not provided. Particularly, the flange 58 is formed with a recess 79 extending from a surface 80 of the flange 58 facing in the axial direction Z into the flange 58 in a direction opposite of the axial direction Z. This recess 79 is formed like the above described recess of the overflow chamber 46. Particularly, this recess 79 extends along the circumference of the outer collar 18. The surface 80 of the flange 58 may optionally be arranged flush with a surface of the holding part 56 facing in the axial direction Z. Furthermore, the outer collar 18 shown in Fig. 5 comprises the features of the outer collar 18 shown in Figs. 1 to 4. Thus, the same reference numbers concern the same elements.

Fig. 6 shows a further inner collar 14, which, in addition to the inner collar 14 shown in Figs. 1 to 4 comprises a wheel 82 configured to interact with a coverslip correction device of the objective 16. Particularly, the wheel 82 is formed as a toothed wheel, and extends in parallel to the optical axis A. The wheel 82 is adapted to rotate about an axis parallel to and offset from the optical axis A. Thus, the wheel 82 is adapted such as to actuate, e.g. rotate, the coverslip correction device of the objective 16, when the wheel 82 is rotated about its axis. The wheel 82 is arranged in a window 84 formed in the inner collar 14, which window 84 is arranged closer to the proximal end of the inner collar 14 than to the distal end 24 of the inner collar 14. Furthermore, the inner collar 14 shown in Fig. 6 comprises the features of the inner collar 14 shown in Figs. 1 to 4. Thus, the same reference numbers concern the same elements.

A further immersion bridge 10 for a microscope 12 is shown in Figs. 7 to 11. Again, the same reference numbers already described above concern the same elements. This immersion bridge 10 differs from the immersion bridge 10 shown in Figs. 1 to 4 in that its inner collar 14 does not have a recess 32 with an O-ring. Instead, the objective contacting section is fit to the objective 16 at the distal side of the objective 16, whereby the objective contacting section 17 is biased radially outwards to provide

a sealing contact with the objective 16. Furthermore, the inner collar 14 comprises an outer collar contacting section 19 formed as a flange extending radially outwards from the deformable part 15, wherein the flange is herein exemplarily arranged at a proximal end side of the inner collar 14. A section of the outer collar contacting section 19 is held, particularly pressed, between the forwarding part 56 and the flange 58 of the fixing device 54, which flange 58 extends substantially radially outwards, too. Thereby, a contact between the outer collar 19 and the inner collar 14 seals the reservoir 22. The reservoir 22 is further limited by the deformable part 15, which is arranged between the outer collar contacting section 19 and the objective contacting section 17 in the axial direction Z. In other words, the objective contacting section 17 joins the deformable part 15 in the axial direction Z, and the outer collar contacting section 19 joins the deformable part 15 in a direction opposite of the axial direction Z. Thus, the deformable part 15 interconnects the objective contacting section 17 and the outer collar contacting section 19.

In the immersion bridge 10 shown in Figs. 7 to 11, the deformable part 15 is formed as a bellows. This bellows has a plurality of folds, and can be expanded in the axial direction Z and contracted/compressed opposite of the axial direction Z, since the outer collar contacting section 19 is fixed to the outer collar 18 and the holding part 56. Furthermore, the deformable part 15 / the bellows is substantially shaped like a shell of a truncated cone. Herein, substantially shaped like a shell of a truncated cone means that the shell, due to the bellows shape, is not planar, but essentially waved, preferably, such that the amplitudes of the waves are essentially equal. This means that the radially outer ends of the folds lie on a plane having the shape of a cone shell. Particularly, the deformable part 15 / the bellows essentially has cylindrical symmetry, and is arranged coaxially with the objective 16. Preferably, the deformable part 15 / the bellows has a smaller diameter at the distal side of the deformable part 15 than at a proximal side of the deformable part 15. Independently of whether the deformable part 15 has its first form or its second form, the objective contacting section 17, and optionally the deformable part 15 is spaced apart from the outer collar 18. Also independently of whether the deformable part 15 has its first form or its second form, the outer collar 18 extends in the axial direction Z beyond the distal end 24 of the inner collar 14. In a plane transversal to the optical axis A, due to the bellows, a distance between the outer collar 18 and the deformable part 15, is successively increased and reduced as the plane is displaced in the axial direction Z.

When the deformable part 15 is being deformed, the volume of the reservoir 22 is modified. Particularly, when the objective 16 is displaced in the axial direction Z, the

objective contacting section 17 is also displaced in the axial direction Z. Since the outer collar contacting section 19 is fixed to the holding part 56, the outer collar contacting section 19 will not move in this situation. Therefore, the deformable part 15 is stretched, i.e., expanded, in the axial direction. As a consequence, the volume of the reservoir 22 is reduced, and immersion fluid 23 shown shaded in Fig. 8 will flow out of the reservoir 22. This immersion fluid 23 will essentially flow down the outer circumferential surface 42 of the outer collar 18 to the flange 58. Herein, the flange 58 is formed like an overflow chamber 46, so that immersion fluid 23, is collected on the flange 58. Exemplarily, to collect the immersion fluid 23, the flange 58 has a substantially L-shaped cross section in a plane comprising the optical axis A of the objective 16, i.e., comprises a radially outer sidewall extending in the axial direction Z. On the other hand, when the objective 16 is moved opposite of the axial direction Z, the level of immersion fluid 23 will be lowered, so that immersion fluid 23 needs to be (re-) introduced in the reservoir 22. Thus, the fluid flow generating device 62 comprises an inlet conduit 64 (in Figs. 7 to 11 exemplarily illustrated by an inlet port) through which immersion fluid 23 can enter the reservoir 22. Particularly, immersion fluid 23 collected in the overflow chamber 46 on the flange 58 may be pumped out through the outlet conduit 65 and into the inlet conduit 64. Thus, the level of immersion fluid 23 will reach the distal end 25 of the outer collar 18, and, subsequently, will essentially be maintained at the level of the distal end 25. By capillary forces, immersion fluid will then keep the gap to the sample closed.

With reference to Figs. 1 to 3, a further embodiment of an immersion bridge 10 for a microscope 12 comprises

- an inner collar 14 adapted to be mounted to an objective 16 of the microscope 12, and
- an outer collar 18 surrounding at least a section of the inner collar 14 and being in contact with the inner collar 14 such that the inner collar 14 and the outer collar 18 form a reservoir 22 for an immersion fluid 23, wherein
- at least a part of the inner collar 14 is adapted to be displaced relative to the outer collar 18 in an axial direction Z of the objective 16 while the inner collar 14 keeps a contact 20 with the outer collar 18 to form the reservoir 22.

Preferably, the reservoir 22 extends beyond a distal end of the inner collar 14 and/or beyond a distal end 26 of the objective 16 in the axial direction Z.

Further preferably, in a state in which the inner collar 14 is mounted to the objective 16, the objective 16 adjoins the reservoir 22.

Further preferably, the inner collar 14 is mounted to the objective 16 such as to seal at least a part of the objective 16 against immersion fluid 23 present in the reservoir 22.

5

Further preferably, the at least part of the inner collar 14 is configured to slide along the outer collar 18 while keeping the contact 20 with the outer collar 18, and/or the contact between the inner collar 14 and the outer collar 18 is configured to seal the reservoir 22.

10

Further preferably, the inner collar 14 is adapted to change a volume of the reservoir 22 when the at least part of the inner collar 14 being displaced in the axial direction Z.

15

Further preferably, the outer collar 18 is adapted to be mounted at a fixed distance in the axial direction Z from at least a part of a sample holder of the microscope, and/or the outer collar 18 comprises a fixing device 54 configured for fixing the outer collar 18 to a holding part 56 provided in the proximity of the outer collar 18.

20

Further preferably, the immersion bridge 10 comprises an overflow chamber 46 adapted to collect immersion fluid 23 escaping from the reservoir 22 when the at least part of the inner collar 14 is displaced in the axial direction Z.

25

Further preferably, the immersion bridge 10 comprises a fluid flow generating device 62 having an inlet conduit 64, a pumping device 66 and a fluid source 68, wherein the inlet conduit 64 is connected to the fluid source 68 and the reservoir 22, and wherein the pumping device 66 is configured to cause the immersion fluid 23 to flow from the fluid source 68 through the inlet conduit into the reservoir 22.

30

Further preferably, the inner collar 14 and/or the outer collar 18 are/is made of an elastic material.

35

With reference to Figs. 1 to 3, in a further embodiment of a microscope 12 according to the present invention, the inner 14 and outer collars 18 are configured such that a distance in the axial direction Z between the outer collar 18 and the sample holder 70 is fixed when the at least part of the inner collar 14 is displaced.

With reference to Figs. 1 to 3, a method of microscopically imaging a sample according to a further embodiment of the present invention comprises the steps of

- providing a microscope 12, and
- displacing at least a part of the inner collar 14 in the axial direction Z of the objective 16 relative to the outer collar 18, and thereby changing a distance between the objective 16 and the sample 72.

Claims

1. An immersion bridge (10) for a microscope (12), comprising:
 - an inner collar (14) adapted to be mounted to an objective (16) of the microscope (12), and
 - an outer collar (18) surrounding at least a section of the inner collar (14) and being in contact with the inner collar (14) such that the inner collar (14) and the outer collar (18) form a reservoir (22) for an immersion fluid (23),
wherein
 - the inner collar (14) comprises a deformable part (15) which is adapted to be deformed such that a length of the inner collar (14) in an axial direction (Z) of the objective (16) is changed, and
 - the outer collar (18) extends in the axial direction (Z) beyond a distal end (24) of the inner collar (14).
2. The immersion bridge according to claim 1, wherein the inner collar (14) comprises
 - an objective contacting section (17) adapted to contact the objective (16), and
 - an outer collar contacting section (19) connected to the outer collar (18),
wherein the deformable part (15) is provided between the objective (16) contacting section (17) and the outer collar contacting section (19).
3. The immersion bridge according to one of the preceding claims, wherein the inner collar (14) is adapted to change a volume of the reservoir (22) when the deformable part (15) is deformed.
4. The immersion bridge according to one of the preceding claims, wherein the inner collar (14) comprises a bellows configured to be expanded or contracted in the axial direction (Z).
5. The immersion bridge according to one of the preceding claims,
wherein the deformable part (15) is substantially shaped like a shell of a truncated cone and/or
wherein a diameter of the deformable part (15) decreases towards a distal end of the deformable part (15).
6. The immersion bridge according to one of the preceding claims,

wherein the outer collar (18) is adapted to be mounted at a fixed distance in the axial direction (Z) from at least a part of a sample holder (70) of the microscope, and/or

wherein the outer collar (18) comprises a fixing device (54) configured for mounting the outer collar (18) to a holding part (56) provided in the proximity of the outer collar (18).

7. The immersion bridge according to one of the preceding claims, wherein the inner collar (14) is configured to contact the objective (16) such as to seal at least a part of the objective (16) against immersion fluid (23) present in the reservoir (22).

8. The immersion bridge according to one of the preceding claims, wherein the deformable part (15) is spaced apart from the outer collar (18).

9. The immersion bridge according to one of the preceding claims, further comprising

an overflow chamber (46) adapted to collect immersion fluid (23) escaping from the reservoir (22) when the deformable part (15) is deformed, and/or

a fluid flow generating device (62) having an inlet conduit (64), a pumping device (66) and a fluid source (68), wherein the inlet conduit (64) is connected to the fluid source (68) and the reservoir (22), and wherein the pumping device (66) is configured to cause the immersion fluid (23) to flow from the fluid source (68) through the inlet conduit (64) into the reservoir (22).

10. The immersion bridge according to one of the preceding claims, wherein the inner collar (14) and/or the outer collar (18) are/is made of an elastic material.

11. A microscope (12), comprising an immersion bridge (10) according to any one of the preceding claims, and an objective (16) to which the inner collar (14) is mounted.

12. The microscope according to claim 11, further comprising a sample holder (70),

wherein the inner collar (14) and the outer collar (18) are configured such that a distance in the axial direction (Z) between the outer collar (18) and the sample holder (70) is fixed when the deformable part (15) is deformed.

13. The microscope according to any one of claims 11 and 12, wherein the microscope (12) is an inverted microscope, wherein the microscope (12) is a multi-photon microscope, or wherein the microscope (12) is an inverted multi-photon microscope.
14. A method of microscopically imaging a sample, comprising the steps of providing a microscope (12) according to any one of claims 11 to 13, and deforming the deformable part (15) of the inner collar (14) such as to change the length of the inner collar (14) in the axial direction (Z) of the objective (16), and thereby changing a distance between the objective (16) and the sample (72).
15. The method of claim 14, further comprising displacing the sample (72), particularly a multi-well plate, held by the sample holder (70) relative to the objective (16) in a direction substantially perpendicular to the axial direction (Z) of the objective (16).

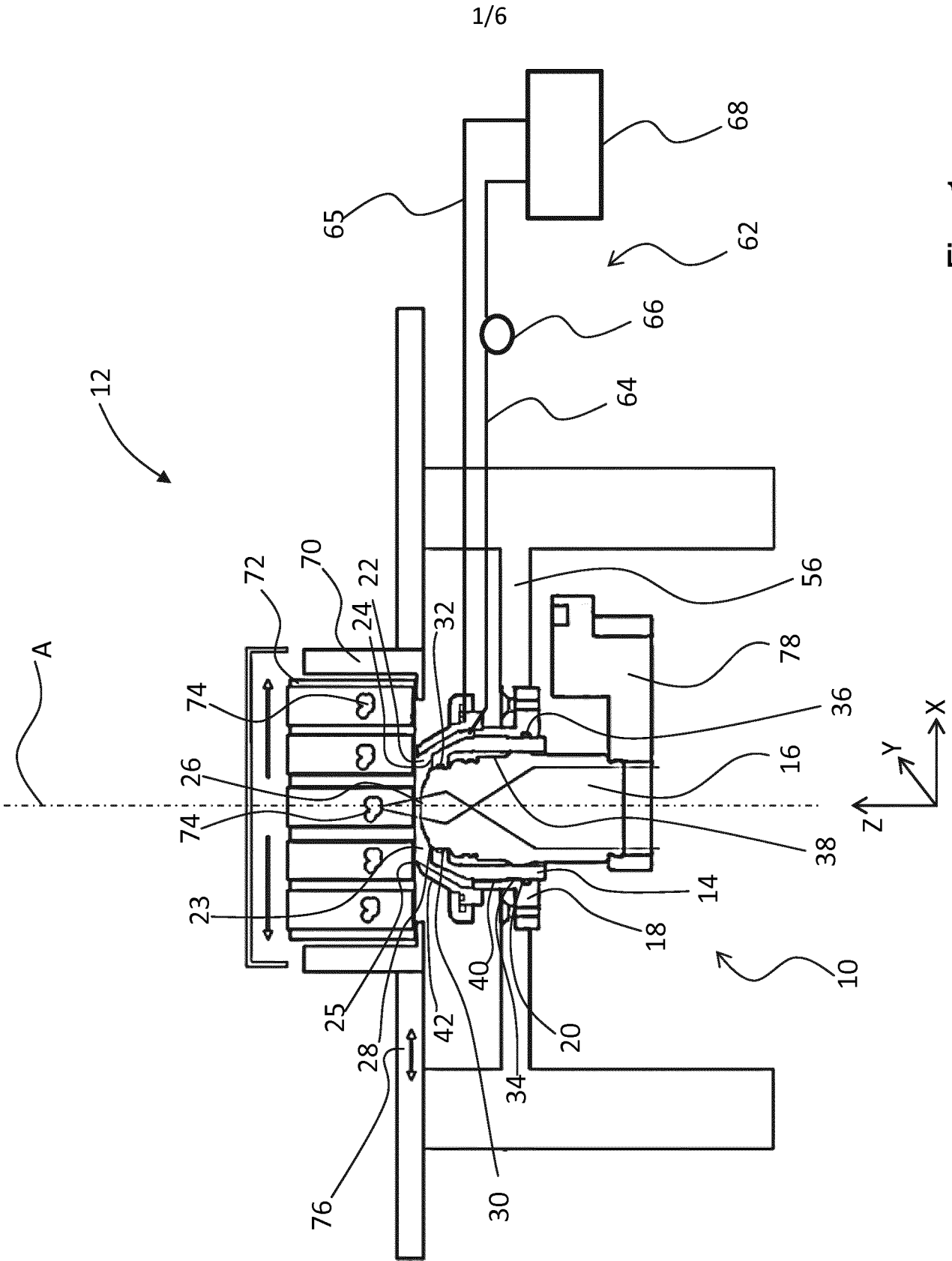

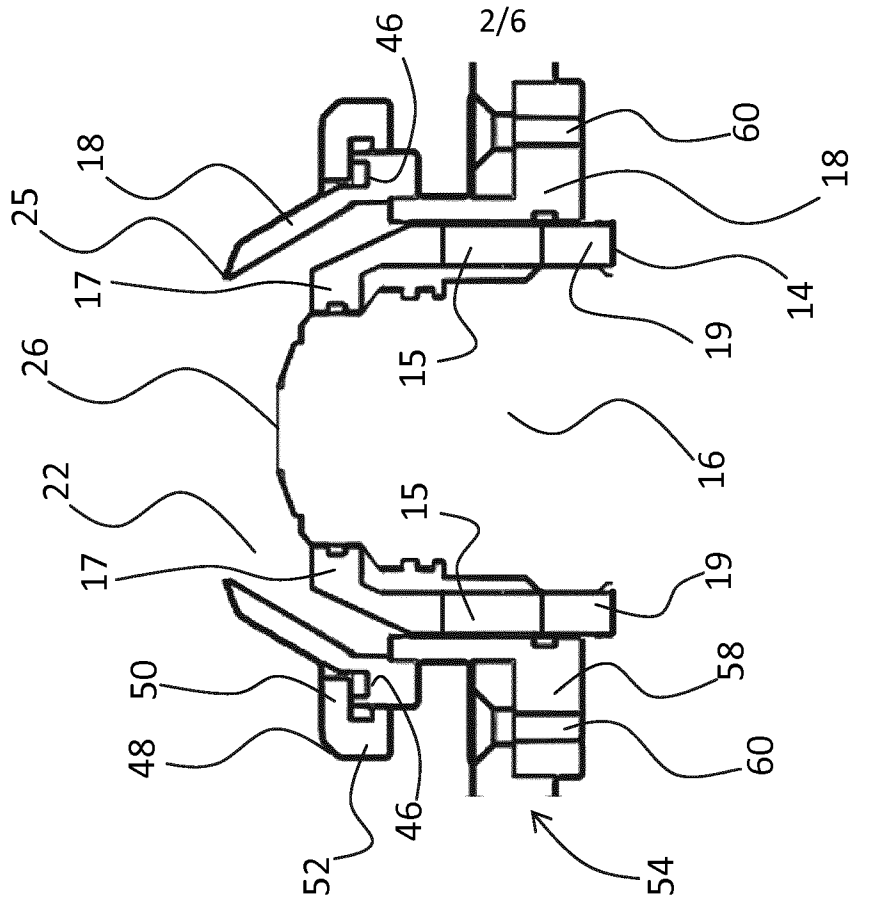

Fig. 3

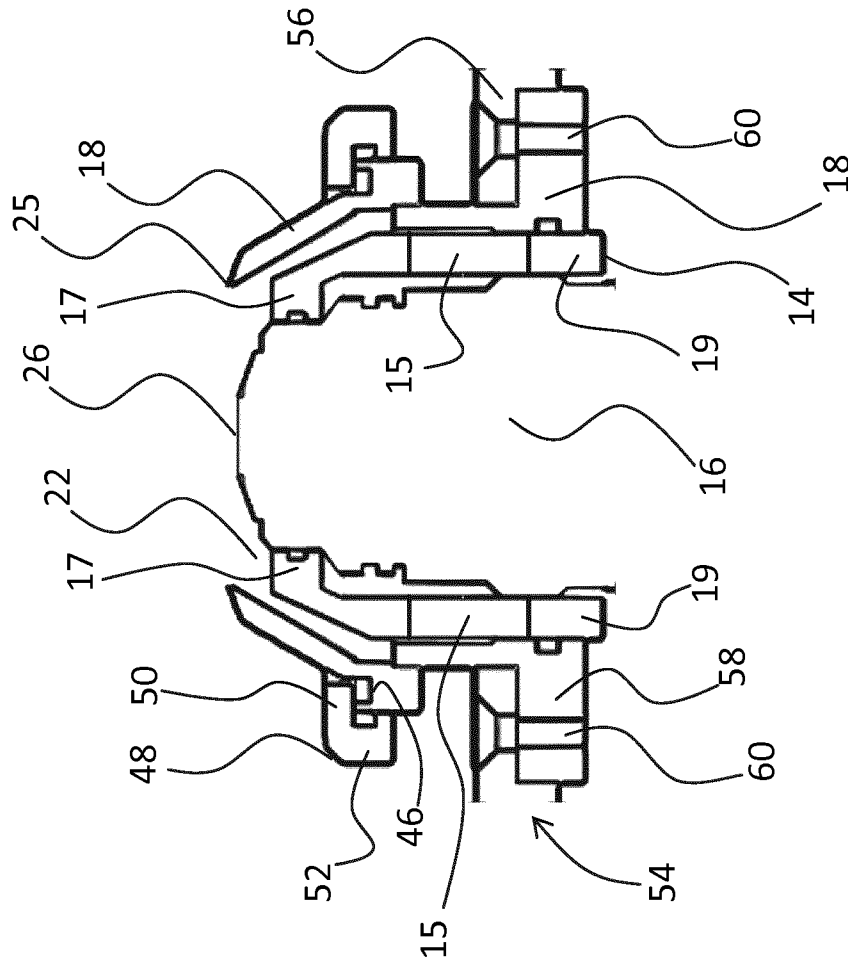

Fig. 2

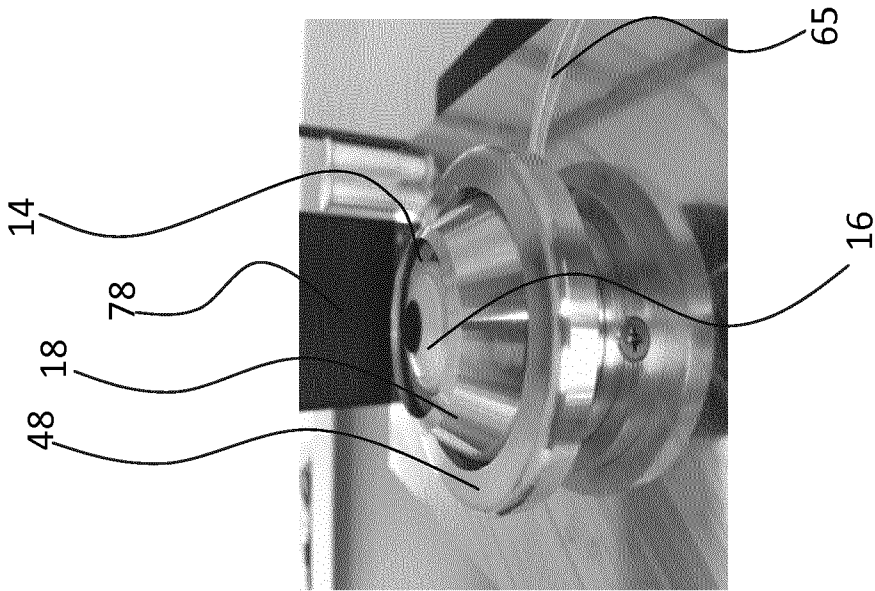

Fig. 4

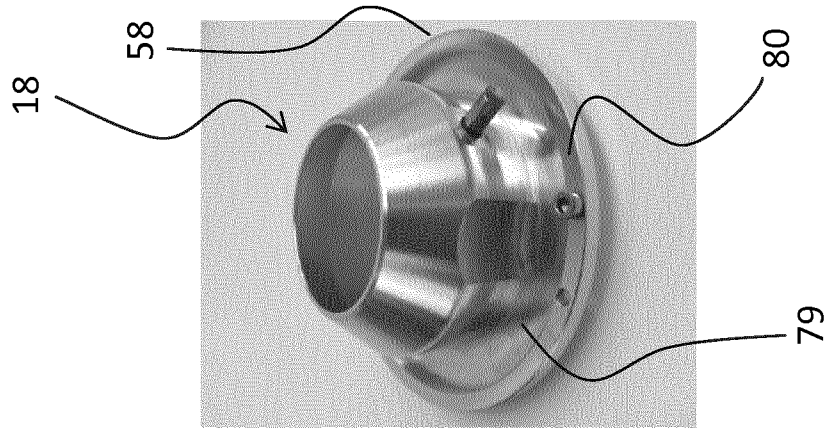

Fig. 5

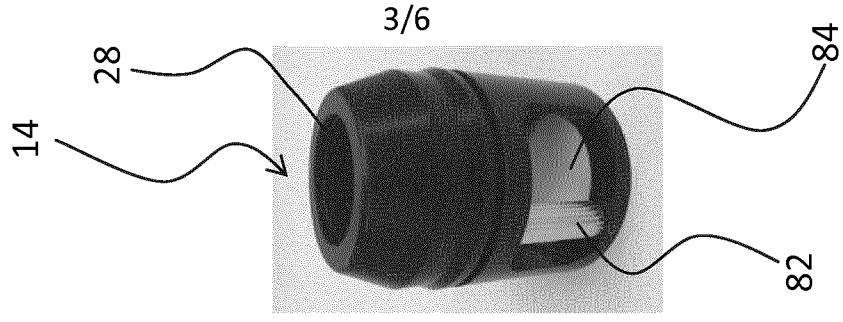

Fig. 6

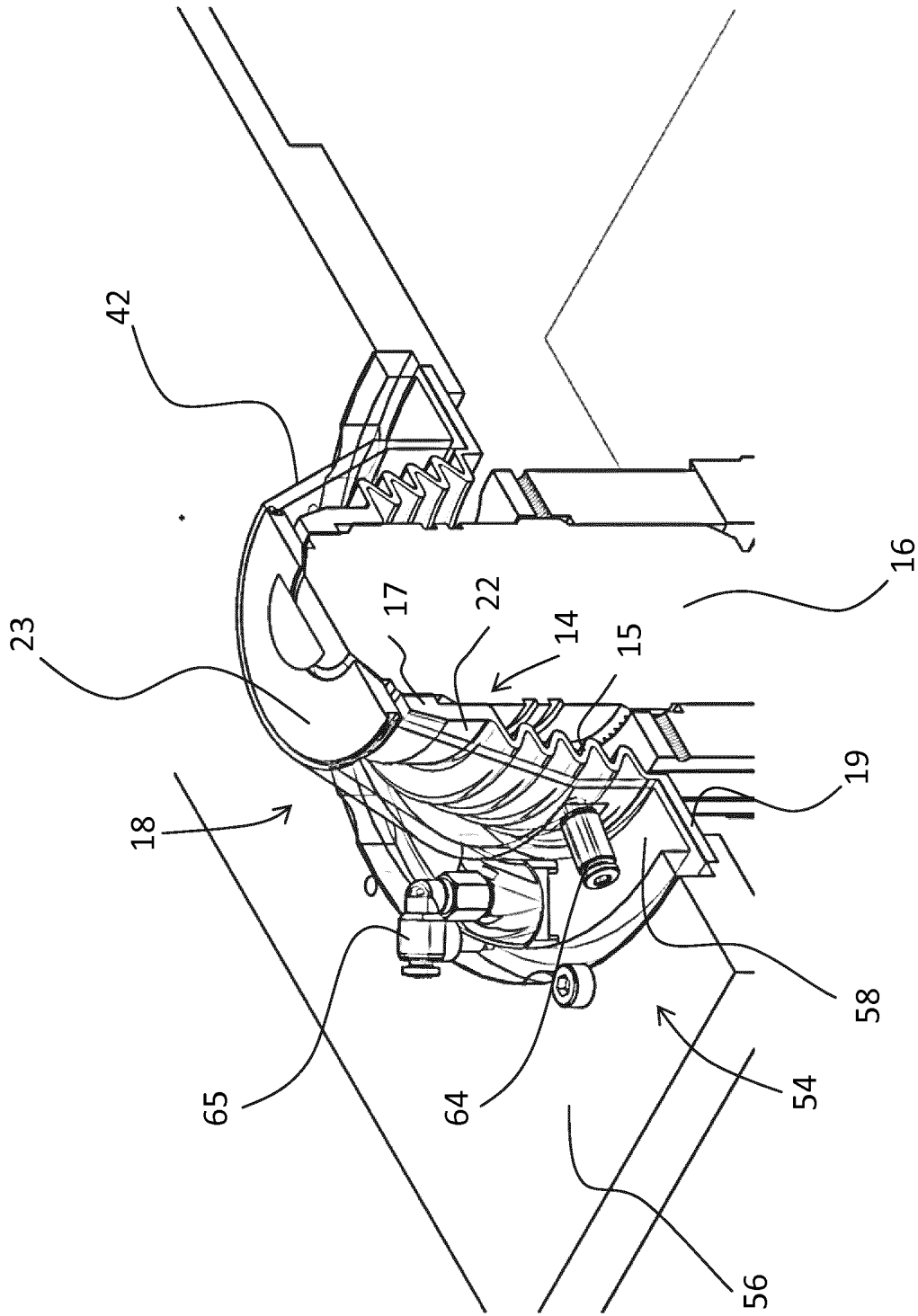

Fig. 7

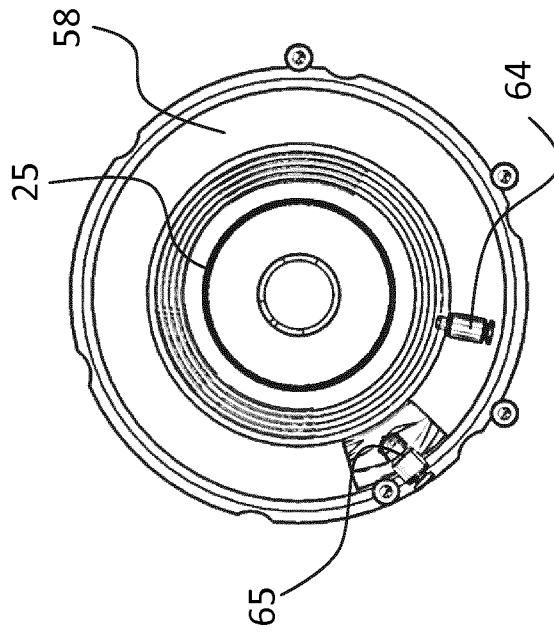

Fig. 9

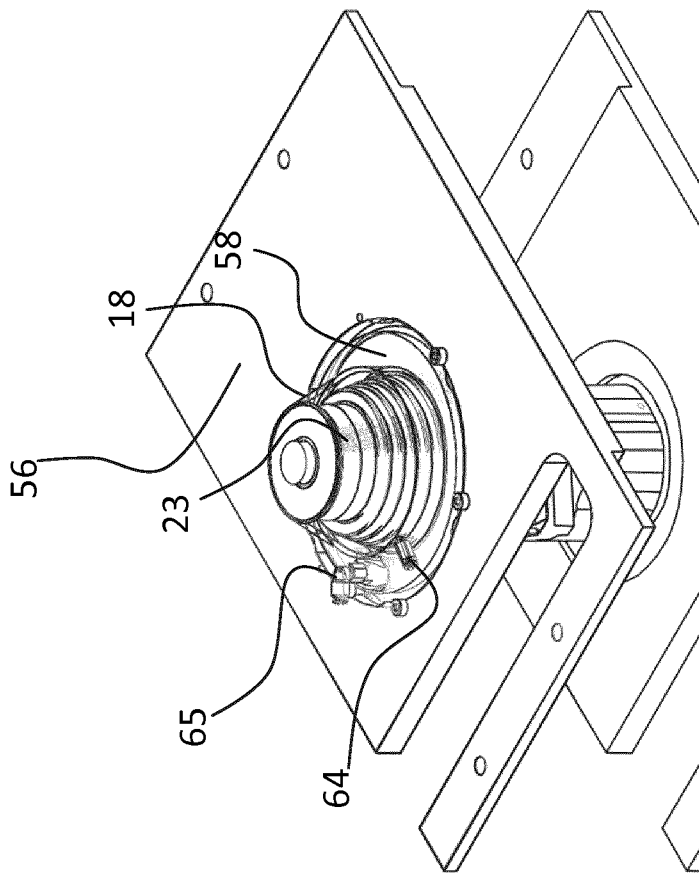

Fig. 8

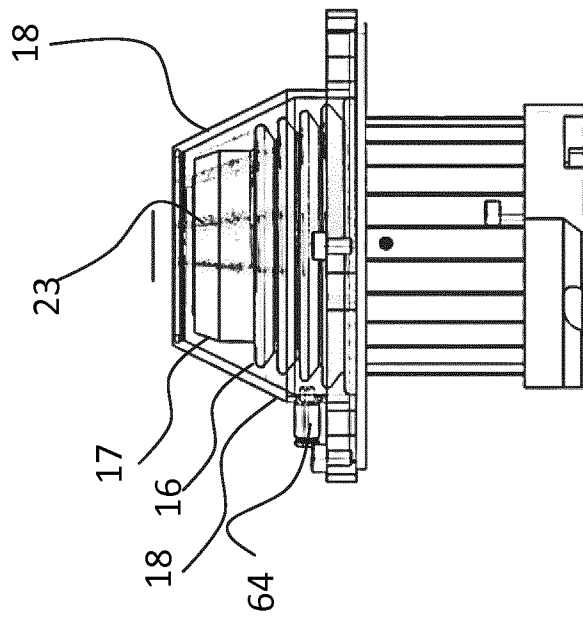

Fig. 10

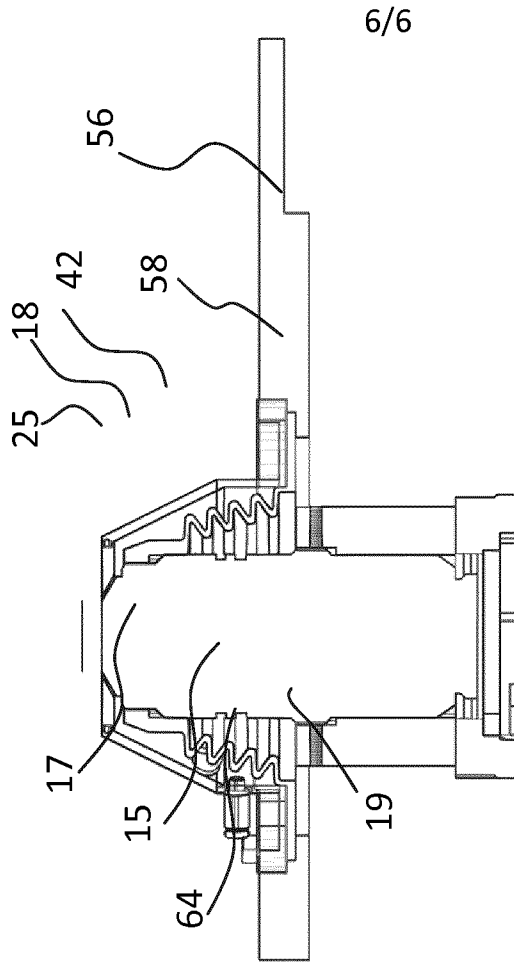

Fig. 11

INTERNATIONAL SEARCH REPORT

International application No
PCT/EP2018/068833

A. CLASSIFICATION OF SUBJECT MATTER
INV. G02B21/33
ADD. G02B21/02

According to International Patent Classification (IPC) or to both national classification and IPC

B. FIELDS SEARCHED

Minimum documentation searched (classification system followed by classification symbols)
G02B

Documentation searched other than minimum documentation to the extent that such documents are included in the fields searched

Electronic data base consulted during the international search (name of data base and, where practicable, search terms used)
EPO-Internal, WPI Data

C. DOCUMENTS CONSIDERED TO BE RELEVANT

Category*	Citation of document, with indication, where appropriate, of the relevant passages	Relevant to claim No.
X	US 2017/045726 A1 (FUJIOKA MICHIRU [JP] ET AL) 16 February 2017 (2017-02-16)	1,3,5-15
Y	figure 8	4
A	paragraph [0084] - paragraph [0097] paragraph [0034] paragraph [0098]; figure 9	2
Y	DE 202 05 080 U1 (LEICA MICROSYSTEMS [DE]) 13 June 2002 (2002-06-13) figure 1 page 4, line 26 - page 5, line 6	4
X	US 7 910 355 B2 (OLYMPUS CORP [JP]) 22 March 2011 (2011-03-22) figures 2,3 column 6, line 63 - column 8, line 33	1,2
	----- -/--	

Further documents are listed in the continuation of Box C.

See patent family annex.

* Special categories of cited documents :

- "A" document defining the general state of the art which is not considered to be of particular relevance
- "E" earlier application or patent but published on or after the international filing date
- "L" document which may throw doubts on priority claim(s) or which is cited to establish the publication date of another citation or other special reason (as specified)
- "O" document referring to an oral disclosure, use, exhibition or other means
- "P" document published prior to the international filing date but later than the priority date claimed

- "T" later document published after the international filing date or priority date and not in conflict with the application but cited to understand the principle or theory underlying the invention
- "X" document of particular relevance; the claimed invention cannot be considered novel or cannot be considered to involve an inventive step when the document is taken alone
- "Y" document of particular relevance; the claimed invention cannot be considered to involve an inventive step when the document is combined with one or more other such documents, such combination being obvious to a person skilled in the art
- "&" document member of the same patent family

Date of the actual completion of the international search 6 September 2018	Date of mailing of the international search report 17/09/2018
Name and mailing address of the ISA/ European Patent Office, P.B. 5818 Patentlaan 2 NL - 2280 HV Rijswijk Tel. (+31-70) 340-2040, Fax: (+31-70) 340-3016	Authorized officer Dedman, Emma

INTERNATIONAL SEARCH REPORT

International application No
PCT/EP2018/068833

C(Continuation). DOCUMENTS CONSIDERED TO BE RELEVANT		
Category*	Citation of document, with indication, where appropriate, of the relevant passages	Relevant to claim No.
A	US 2006/274424 A1 (OKAZAKI KENYA [JP] ET AL) 7 December 2006 (2006-12-07) figures 8,9 paragraph [0055] - paragraph [0063] -----	1-15
A	JP 3 203698 B2 (NIPPON KOGAKU KK) 27 August 2001 (2001-08-27) figure 1 paragraph [0010] - paragraph [0012] -----	1,14
A	WO 2007/135762 A1 (TOKAI HIT CO LTD [JP]; TSUCHIYA HIDEHARU [JP]) 29 November 2007 (2007-11-29) figure 1 -----	1,14
A	WO 2014/043526 A2 (UNIV BRANDEIS [US]; INGERSOLL CHARLES G [US]) 20 March 2014 (2014-03-20) paragraph [0081] - paragraph [0082]; figures 5,6 -----	4
A	US 2015/015943 A1 (SCHEPS ALEXANDER [DE] ET AL) 15 January 2015 (2015-01-15) figures 1-3 -----	1,14
A	US 2010/315705 A1 (HARADA MITSUO [JP] ET AL) 16 December 2010 (2010-12-16) paragraph [0042] - paragraph [0046]; figures 3,4 -----	1,9,14

INTERNATIONAL SEARCH REPORT

Information on patent family members

International application No
PCT/EP2018/068833

Patent document cited in search report	Publication date	Patent family member(s)	Publication date	
US 2017045726	A1	16-02-2017	CN 106489092 A	08-03-2017
			DE 112015001461 T5	15-12-2016
			GB 2541308 A	15-02-2017
			JP 6144419 B2	07-06-2017
			JP W02015182213 A1	20-04-2017
			US 2017045726 A1	16-02-2017
			WO 2015182213 A1	03-12-2015

DE 20205080	U1	13-06-2002	NONE	

US 7910355	B2	22-03-2011	DE 602005004749 T2	12-02-2009
			EP 1677136 A1	05-07-2006
			JP 4668609 B2	13-04-2011
			JP 2006187204 A	20-07-2006
			US 2006141613 A1	29-06-2006

US 2006274424	A1	07-12-2006	EP 1703311 A1	20-09-2006
			JP 4253592 B2	15-04-2009
			JP 2005195792 A	21-07-2005
			US 2006274424 A1	07-12-2006
			WO 2005066682 A1	21-07-2005

JP 3203698	B2	27-08-2001	JP 3203698 B2	27-08-2001
			JP H0560981 A	12-03-1993

WO 2007135762	A1	29-11-2007	NONE	

WO 2014043526	A2	20-03-2014	EP 2895909 A2	22-07-2015
			JP 2015529858 A	08-10-2015
			US 2015248002 A1	03-09-2015
			US 2017248779 A1	31-08-2017
			WO 2014043526 A2	20-03-2014

US 2015015943	A1	15-01-2015	DE 102013011544 A1	15-01-2015
			EP 2824497 A1	14-01-2015
			JP 2015018237 A	29-01-2015
			US 2015015943 A1	15-01-2015

US 2010315705	A1	16-12-2010	AT 543117 T	15-02-2012
			EP 1717628 A1	02-11-2006
			EP 2256535 A1	01-12-2010
			JP 4587960 B2	24-11-2010
			JP 5107398 B2	26-12-2012
			JP 2010217930 A	30-09-2010
			JP 2010262306 A	18-11-2010
			JP W02005078503 A1	18-10-2007
			US 2006275918 A1	07-12-2006
			US 2010315705 A1	16-12-2010
			WO 2005078503 A1	25-08-2005
