



INTERNATIONAL APPLICATION PUBLISHED UNDER THE PATENT COOPERATION TREATY (PCT)

<p>(51) International Patent Classification ⁷ : A61C 17/36</p>	<p>A1</p>	<p>(11) International Publication Number: WO 00/41645 (43) International Publication Date: 20 July 2000 (20.07.00)</p>
<p>(21) International Application Number: PCT/US00/00435 (22) International Filing Date: 7 January 2000 (07.01.00) (30) Priority Data: 09/229,979 13 January 1999 (13.01.99) US 09/404,972 24 September 1999 (24.09.99) US (71) Applicant: OPTIVA CORPORATION [US/US]; 35301 South-east Center Street, Snoqualmie, WA 98065 (US). (72) Inventors: HALL, Scott, E.; 14445 124th Avenue Northeast #E-28, Kirkland, WA 98034 (US). LARIMER, James, N.; 7414 91st Avenue Southeast, Mercer Island, WA 98040 (US). MILLER, Kevin; 16627 Southeast 40th Place, Bellevue, WA 98008 (US). TAYLOR, Richard; P.O. Box 1146, Fall City, WA 98024 (US). (74) Agent: PUNTIGAM, Clark, A.; 2033 6th Avenue #1020, Seattle, WA 98121 (US).</p>		<p>(81) Designated States: AE, AL, AM, AT, AU, AZ, BA, BB, BG, BR, BY, CA, CH, CN, CU, CZ, DE, DK, EE, ES, FI, GB, GD, GE, GH, GM, HR, HU, ID, IL, IN, IS, JP, KE, KG, KP, KR, KZ, LC, LK, LR, LS, LT, LU, LV, MD, MG, MK, MN, MW, MX, NO, NZ, PL, PT, RO, RU, SD, SE, SG, SI, SK, SL, TJ, TM, TR, TT, UA, UG, UZ, VN, YU, ZA, ZW, ARIPO patent (GH, GM, KE, LS, MW, SD, SL, SZ, TZ, UG, ZW), Eurasian patent (AM, AZ, BY, KG, KZ, MD, RU, TJ, TM), European patent (AT, BE, CH, CY, DE, DK, ES, FI, FR, GB, GR, IE, IT, LU, MC, NL, PT, SE), OAPI patent (BF, BJ, CF, CG, CI, CM, GA, GN, GW, ML, MR, NE, SN, TD, TG).</p> <p>Published <i>With international search report. Before the expiration of the time limit for amending the claims and to be republished in the event of the receipt of amendments.</i></p>

(54) Title: FLUID-DISPENSING AND REFILLING SYSTEM FOR A POWER TOOTHBRUSH

(57) Abstract

The fluid delivery/refilling system includes a unit-of-use fluid reservoir for dentifrice or medication within a head portion of a power toothbrush, which is removable from the remainder thereof. A pump element is located in the brushhead and is configured so that the back and forth movement of the brushhead in operation results in fluid moving from the reservoir to a dispensing valve located in the brushhead. The dispensing valve has an end portion which is normally closed, opening under pressure of fluid from the pump. The refilling assembly is separated from the toothbrush and is configured to fit over the top of the toothbrush. A pump used in a power toothbrush for fluid delivery to the bristles. The pump includes a pump chamber with a piston ball located therein. The pump includes a fluid exit channel which connects the discharge end of the pump chamber with an opening in the brushhead in which the dispensing valve is located.

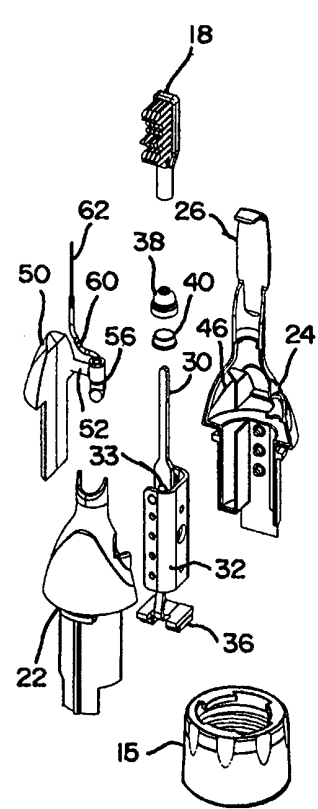

FOR THE PURPOSES OF INFORMATION ONLY

Codes used to identify States party to the PCT on the front pages of pamphlets publishing international applications under the PCT.

AL	Albania	ES	Spain	LS	Lesotho	SI	Slovenia
AM	Armenia	FI	Finland	LT	Lithuania	SK	Slovakia
AT	Austria	FR	France	LU	Luxembourg	SN	Senegal
AU	Australia	GA	Gabon	LV	Latvia	SZ	Swaziland
AZ	Azerbaijan	GB	United Kingdom	MC	Monaco	TD	Chad
BA	Bosnia and Herzegovina	GE	Georgia	MD	Republic of Moldova	TG	Togo
BB	Barbados	GH	Ghana	MG	Madagascar	TJ	Tajikistan
BE	Belgium	GN	Guinea	MK	The former Yugoslav Republic of Macedonia	TM	Turkmenistan
BF	Burkina Faso	GR	Greece	ML	Mali	TR	Turkey
BG	Bulgaria	HU	Hungary	MN	Mongolia	TT	Trinidad and Tobago
BJ	Benin	IE	Ireland	MR	Mauritania	UA	Ukraine
BR	Brazil	IL	Israel	MW	Malawi	UG	Uganda
BY	Belarus	IS	Iceland	MX	Mexico	US	United States of America
CA	Canada	IT	Italy	NE	Niger	UZ	Uzbekistan
CF	Central African Republic	JP	Japan	NL	Netherlands	VN	Viet Nam
CG	Congo	KE	Kenya	NO	Norway	YU	Yugoslavia
CH	Switzerland	KG	Kyrgyzstan	NZ	New Zealand	ZW	Zimbabwe
CI	Côte d'Ivoire	KP	Democratic People's Republic of Korea	PL	Poland		
CM	Cameroon	KR	Republic of Korea	PT	Portugal		
CN	China	KZ	Kazakstan	RO	Romania		
CU	Cuba	LC	Saint Lucia	RU	Russian Federation		
CZ	Czech Republic	LI	Liechtenstein	SD	Sudan		
DE	Germany	LK	Sri Lanka	SE	Sweden		
DK	Denmark	LR	Liberia	SG	Singapore		
EE	Estonia						

5,309,590 to Giuliani *et al.* Some representative examples of fluid-dispensing systems for manual and power toothbrushes include U.S. Patents No. 3,547,110 to Balamuth; 5,066,155 to English *et al.*; 5,208,933 to Lustig and 5,062,728 to Kuo.

5 The reservoir for the dentifrice is typically located either in the handle portion of the toothbrush, such as shown in the '590 patent, or in a separate device, such as shown in the '110 patent. In some cases, the reservoir is disposable, so that when the fluid in the reservoir is depleted, the reservoir
10 itself is discarded and a replacement reservoir is inserted. Such a system is shown in the '370 patent. In other systems, the reservoir is refillable. Typically, the reservoir contains sufficient fluid for a substantial number of individual uses of the fluid dentifrice or medication.

15 Various systems for dispensing the fluid from the brushhead are also known. In some cases, the fluid is dispensed from a plurality of openings in the brushhead itself, such as shown in the '492 patent, while in other cases, the fluid is dispensed through the bristles themselves, such as shown in U.S.
20 Patent No. 4,039,261 to Evans.

 Fluid-dispensing systems in general, however, have often been difficult to operate, unreliable and expensive. Many such systems are too complex for reliable operation and/or are incapable of working properly, while other systems fail due to
25 clogging of the fluid lines or exit openings, or poor pumping action, among other reasons. Also, it is difficult to design a system with a pump small enough to fit within a typical toothbrush structure. External pumps are often used, which are bulky and expensive. The pump element, whether on-board or
30 external, is typically too complex for sustained, reliable operation, or too expensive to be practical. For all of these reasons, fluid-dispensing systems for both manual and power toothbrushes have not been particularly successful.

 Because of the potential benefits, it is desirable to
35 have a fluid-dispensing system in a power toothbrush which is

reliable and yet sufficiently simple in design that it is practical to manufacture and maintain.

Disclosure of the Invention

5 Accordingly, the present invention includes a fluid delivery system for a power toothbrush, comprising: a reservoir which is located within a toothbrush head portion of a power toothbrush, wherein the head portion is removable from the handle portion of the toothbrush; a pump member and associated
10 fluid line for moving fluid from the reservoir to a brushhead part of the head portion of the toothbrush; and a dispensing member located in the brushhead, connected to the fluid line, for receiving fluid from the pump member and permitting exit of fluid therefrom to the vicinity of the bristles, under pressure
15 provided by the pump member.

 The invention also includes a pump for use in the fluid delivery system for a power toothbrush, comprising: a pump member for moving fluid from a reservoir to a dispensing member located in a brushhead portion of a toothbrush, wherein
20 the pump member includes a chamber and a ball which moves within the chamber in response to movement of the brushhead during operation of the toothbrush, wherein movement of the ball in the chamber results in fluid moving from the reservoir into the pump member and then out of the pump member with sufficient pressure
25 to move the fluid to the dispensing member and then outwardly therefrom.

 The invention also includes a refilling system for a power toothbrush for use with a power toothbrush having an internal reservoir located therein from which fluid in operation
30 is moved to the bristles in the brushhead, the internal reservoir having a small volume, at least one unit of use, the refilling system comprising: an external refilling assembly which is separate from the power toothbrush, the refilling assembly having a fluid reservoir which contains a substantial
35 volume of fluid, at least a plurality of unit-of-use volumes of fluid; means associated with the refilling assembly and the

power toothbrush for producing a fluid path from the refilling assembly to the power toothbrush; and means for moving fluid from the refilling assembly to the internal reservoir in the power toothbrush.

5

Brief Description of the Drawings

Figure 1 is a schematic view showing a toothbrush which incorporates the fluid-dispensing system of the present invention.

10 Figure 2 is a partially exploded view of the head portion of the toothbrush of Figure 1.

Figure 3 is a schematic view showing a portion of the fluid-dispensing system of the present invention.

15 Figures 4A and 4B are cross-sectional views of a refill valve of the fluid-dispensing system of the present invention, with and without a refilling needle therein.

Figure 5 is a partially exploded view showing the pump member and the brushhead.

20 Figures 6 and 7 are cross-sectional views showing the movement of fluid between the reservoir and the brushhead, including the pump element which moves the fluid.

Figure 8 is a cross-sectional view showing the dispensing valve of the fluid delivery system.

25 Figures 9 through 13 are diagrams showing the refilling assembly of the present invention and the process of refilling the on-board reservoir of the toothbrush of Figure 1.

Figure 14 is a top plan view of the refilling assembly.

30 Figure 15 is a partially exploded view of an alternative embodiment of the pump member of Figures 5-8.

Figure 16 is a cross-sectional view of the pump member of Figure 15.

Figure 17 is another cross-sectional view of the pump member of Figure 15.

35 Figure 18 is a cross-sectional view of the pump chamber portion of the pump member of Figure 15.

Figure 19 is a schematic view of a top portion of the pump member of Figure 15.

Figure 20 is another cross-sectional view showing the pump chamber portion of the pump member of Figure 15.

5

Best Mode for Carrying Out the Invention

Figure 1 shows a typical power toothbrush in which the fluid-dispensing and refilling system of the present invention is used. It should be emphasized, however, that the present invention is not limited to the particular power toothbrush shown and described or a particular brushhead movement. Rather, the principles of the present invention can be used with a variety of power toothbrush configurations and structural arrangements, with some aspects of the invention even being usable in a manual toothbrush.

The power toothbrush of Figure 1, shown generally at 10, comprises a handle portion 12 and a removable head portion 14. In the handle portion is a power unit, including an electromagnetic driver and a battery for moving a brushhead 18, which is mounted on a pivoting arm, in a side-to-side manner, as discussed in more detail below. Toothbrush 10 is controlled by a pushbutton on/off switch 19.

Figure 2 is an exploded view showing the principal parts of the head portion 14 of the toothbrush of Figure 1. The head portion includes two mating body parts 22 and 24, which are fitted together about a support member 32. Body part 24 includes an extended shield 26 for brushhead 18. Brushhead 18 is mounted on a pivot arm 30, which in turn is mounted for pivoting action about a torsion pin pivot member 33, which extends between opposing sides of support member 32. Pivot arm 30 is driven by an electromagnetic driver (not shown) in handle portion 12 of the toothbrush, operating on magnetic elements 36 at the end of pivot arm 30. The structure and operation of such a toothbrush is described in more detail in U.S. Patent No. 5,378,153 to Giuliani et al, owned by the same assignee as the present invention.

Rubber seal 38 and plastic ring 40 seal arm 30 to the body parts 22 and 24, preventing moisture from moving back into head portion 14. A nut portion 15 connects head portion 14 to handle portion 12 through a threaded connection. Positioned in an internal cavity 46 formed by the two mated body portions 22 and 24 is an on-board reservoir 50. On-board reservoir 50 is generally arrow-shaped in configuration, approximately 2 inches long, having front and rear similar flexible plastic panels joined together along the peripheral edges thereof. On-board reservoir 50 in the embodiment shown typically holds sufficient fluid for one brushing use, i.e. one "unit of use". This relatively small on-board reservoir volume is significant, in that it permits a fluid reservoir to be positioned in the removable head portion 14 of the toothbrush structure of Figure 1. This arrangement has a number of advantages, including a relatively short fluid travel path and an overall simplicity of structure. Accordingly, when head portion 14 is replaced, such as when the bristles of brushhead 18 are worn, reservoir 50 as well as the associated fluid delivery system is part of the replacement unit.

Referring to Figures 2 and 3, extending from reservoir 50 is a short tube section 52 which fits into a lower end of a refilling valve 56, which is explained in more detail below. Extending from the side of refilling valve 56, above the entry point of tube section 52, is a flexible fluid line 60 which in the embodiment shown is flexible plastic material approximately 0.10 inches in diameter and approximately 1 inch long. Fluid line 60 connects to a fluid inlet tube 62, which has a diameter of approximately 0.05 inches, and extends into brushhead 18 at a proximal end 64 thereof.

Figures 5-8 show the fluid delivery structure within brushhead 18, including a fluid pump 66, a fluid-delivery cavity 68 which extends from pump 66 in a base element 76, and a fluid-dispensing valve 70 which extends upwardly from delivery cavity 68, through brushhead 18 above surface 71 of the brushhead, into the bristle region 72 of the toothbrush.

Fluid inlet tube 62 extends into brushhead 18 to where it contacts the entry region 83 (Figure 7) of fluid pump 66. Fluid pump 66 is an irregular block of material having a cylindrical opening 75 which extends laterally thereof. Fluid pump 66 is positioned at one end of the elongated base element 76. Elongated base element 76 is approximately 0.03 inches thick and has a cutout or cavity portion 68 which extends from pump 66 to approximately the other end 80 of base element 76. Cavity portion 68 in the embodiment shown is approximately 0.015 inches deep.

As shown in Figure 5, fluid pump 66 and base element 76 in the embodiment shown form a unitary member, which fits into a matching cavity 77 in the lower surface of the brushhead. Cavity 77 is configured to provide a solid seal for the ends of cylindrical opening 75 in pump 66 when the unitary member is correctly positioned in cavity 77. Fluid delivery cavity 68 connects exit portion 85 of pump 66 and the lower end of dispensing valve 70. A lip 84 surrounding cavity 68 in base element 76 contacts a mating surface 87 in the brushhead when the unitary pump and base element are in place, providing a fluid-tight seal around cavity 68. Cavity 68 thus serves as a fluid-delivery means connecting pump 66 with dispensing valve 70.

Pump 66 is configured with opposing corners being relieved, the relieved portions extending, respectively, from the opposing open ends of cylindrical opening 75, around adjacent corners of the block, to a point approximately half-way along the adjacent side of the pump 66. This configuration is shown most clearly in Figures 6 and 7. A spherical ball 63, which functions as a piston, rides in cylindrical opening 75. Entry region 83 overlaps one end of opening 75, while exit region 85 overlaps the other end of opening 75. Exit region 85 connects to fluid delivery cavity 68 in the base element. Hence, there is a complete fluid path from tube 62 to cavity 68. The ball 63 moves within cylindrical opening 75, producing a

pumping action for the fluid which enters opening 75, as the brushhead moves from side to side in operation.

5 Proper clearance between ball 63 and the interior surface of cylindrical opening 75 is important for correct pumping operation, with adequate fluid pressure to valve 70. In the embodiment shown, the clearance is approximately 0.0015 inches.

10 In operation, during the outlet stroke, as the ball moves toward the exit or outlet region 85 for opening 75, fluid is moved both toward the outlet region and also around the piston toward the inlet region 83 for opening 75. On the return stroke of the piston (toward the inlet region 83), the closed dispensing valve forces fluid to pass around the ball toward the outlet region, in preparation for the next outlet stroke. The
15 flow rate is partially dependent on the amplitude of the brushhead movement and hence is a function of the loading of the toothbrush. When the brushhead system is a resonant system, such as described in the '153 patent, the flow rate increases when the bristles are in contact with the teeth. The pumping
20 action will occur with or without a dispensing valve at the end of the fluid path and is self-priming in operation, i.e. it can pump air.

The action of the piston ball 63 moving back and forth in the opening due to the back and forth action of the
25 brushhead forces fluid out of the outlet region 85 of the pump and allows fluid to enter inlet region 83 from fluid tube 62. In the outlet region 85, fluid moves around the corner of the pump block and along the adjacent side, bound by the walls of the brushhead cavity into which the pump and base element fits.
30 The fluid moves into cavity 68 in base element 76, around a small diverting member 92 near the end of cavity 68 into internal opening 94 of base portion 96 of the dispensing valve 70.

The dispensing valve 70 is shown in Figure 8.
35 Internal opening 94 is approximately 0.07 inches in diameter. Valve 70 in the embodiment shown is 0.34 inches high. Valve 70

is known as a "duck bill" valve because it has two converging lip portions 98 and 100 at the free end 101 thereof. The two lip portions 98 and 100 are normally closed, i.e. pressed together, to prevent leakage and/or backflow of fluid. Fluid is moved by the back and forth action of the brushhead and the action of the pump, into valve 70, with sufficient pressure to force apart the two lips 98 and 100, dispensing the fluid into the area of the bristles in spurts on each "outlet" stroke of the piston. The valve shown not only prevents backflow of fluid, which is a potential source of contamination, but also assists in making the pump self-priming as well as determining the output flow speed and velocity.

The "duck bill" valve 70 is conventional, made out of a flexible plastic material to facilitate opening and closure of the lip portions 98 and 100. In the embodiment shown, the free end of valve 70 extends above the base of the brushhead approximately 0.18 inches. It is located approximately in the middle of the bristles both longitudinally and laterally, although this is not necessary to proper operation of the system.

In operation, as brushhead 18 moves from side to side, such that piston ball 63 moves back and forth between the inlet and outlet ends of the cylindrical opening 75, small volumes (approximately 0.00013 cc) of fluid will be successively moved from the reservoir through the pump 66 and then to the dispensing valve 70. The lips 98, 100 of valve 70 part slightly with each small surge of fluid, but close again after the surge has passed. The successive amounts of fluid are forced out into the bristle area and are delivered to the desired region of the teeth by the action of the moving bristles.

Hence, there is a continuous (in small successive spurts) delivery of fluid to the area of the bristles during bristle action. This system has several advantages over existing systems. First, the continuous (in the form of successive spurts or pulses) nature of the fluid delivery prevents the effect of the fluid from becoming diluted over the

brushing time, which is the case when the fluid, be it conventional dentifrice or oral medication, is administered at the start of brushing. Second, the effect of the fluid is enhanced with the present invention because the fluid can be provided directly to the area of bristle action.

In the case of the particular action of the toothbrush shown, in the manner and with the operating characteristics, including frequency and amplitude, set forth in the '590 patent, the effect of the fluid, dentifrice or medication, is frequently enhanced due to the cavitation and other action of the fluid created by the bristle action. This is in addition to the precise delivery of the fluid to specific regions of interest in the mouth, including the gingival areas in the gum line and between the teeth.

Hence, the fluid-dispensing system of the present invention is not only practical and reliable, but it has a significant therapeutic effect when used under selected operating conditions, such as those produced by the action of the toothbrush in the '590 patent.

As indicated above, reservoir 50 in the embodiment shown has a unit-of-use volume, i.e. the volume is sufficient for one brushing of typical length, i.e. two minutes or so. The system of the present invention also includes a refilling system for the unit-of-use reservoir. The refilling system is shown in Figures 9-14.

Figure 9 shows the refiller apparatus 102 in general, for use with the toothbrush of Figure 1. To refill the unit-of-use reservoir 50 in the head portion of the toothbrush, the refiller apparatus 102 fits down over the top of the toothbrush, with the head portion and the brushhead portion of the toothbrush extending up into the interior of the refiller apparatus 102. The refiller apparatus includes a housing 104, with a viewing window 106 which shows a portion of the interior of the refiller apparatus so that the user can ascertain proper insertion of the toothbrush.

Figure 10 shows the various portions of the refiller apparatus. It includes housing 104 and an interior core element 110. Core element 110 includes a lower portion 112 which is configured to receive and mate with an upper part of the head portion of the toothbrush. Brushhead 18 extends upwardly through an opening 114 in core element 110. Core element 110 has opposing side tracks 116 and 118 which extend from a lower edge 117 of the core element upwardly thereof, on the exterior surface 119 thereof. Tracks 116 and 118 mate with corresponding mating channels (not shown) on interior surface 120 of housing 104.

This arrangement permits the core element 110 to move up and down a selected distance within housing 104 in a reliable fashion, without rotation or side-to-side movement. Extending upwardly from the top of lower portion 112 of core element 110 is a narrow extending member 122, with a horizontal lip 124 at the upper end thereof and two spaced wing elements 126 and 128 at the base thereof, adjacent the top of the lower portion. Lower portion 112 of core element 110 also includes a flat surface portion 130 at the upper end thereof, adjacent wing element 128. Extending through this flat surface portion 130 is a small opening 132. Opening 132 conveniently and readily accommodates a refilling needle from the refilling apparatus.

Positioned above core element 110 is a pump assembly 140, which includes therein a refilling reservoir 111. Positioned within pump assembly 140 is a fill needle 142, which is oriented vertically with a base portion 141 of the needle mounted to a seal assembly 144, which fits into a pump chamber portion 145 of the pump assembly 140 in a sealing relationship to the interior peripheral surface of the pump chamber. In the top of the pump assembly 140 is an opening 150 which connects with refilling reservoir 111 within the pump assembly. A top element 154 snaps onto an upper lip 156 of pump assembly 140. At the center of top element 154 is a cavity-like portion 158, at the bottom of which is an opening 160 (shown partially in Figure 10), which can be either in or out of registry with

opening 150 in the pump assembly, depending upon the rotational position of the top element. The refiller reservoir 111 may be filled through these two openings 160 and 150 when the top element is in the correct position such that the two openings
5 are in registry.

Figures 11-13 are cross-sectional diagrams showing the sequence of steps in the refilling process for the unit-of-use reservoir 50 in the toothbrush. In Figure 11, the toothbrush has been just positioned within the refiller apparatus, with the core element 110 being at its lowermost
10 position. In this position, lip 124 of extending member 122 remains in a receiving slot 170 within the refiller apparatus, as is the case when there is no toothbrush within the refiller. In this position, the lower end 164 of fill needle 142 just
15 penetrates through opening 132 in surface 130 of the core element. The needle base 141 and seal assembly 144 are in their lowermost position within pump chamber 145. A spring 174 within pump chamber 145 tends to maintain the needle base and seal assembly in their lowermost position. Chamber inlet valve 176
20 at the lower end of pump chamber 144 is in its closed (lowered) position, as shown. The body of needle 142 is sealed to the lower edge member 149 of chamber 145 by seal 178.

As the toothbrush is inserted further into core element 110 by a user, the particularly configured curved
25 shoulders of the head portion of the toothbrush push against the wing elements 126, 128 at the base of extending member 122 (Figure 10). This action forces the extending member 122 backwardly sufficiently that lip 124 at the top of the extending member moves out of receiving slot 170, allowing the core member
30 to move further up within the refiller apparatus. Further upward pressure on the toothbrush by the user results in further upward movement of the core element 110, with fill needle 142 penetrating further through opening 132 in the core element and into refiller valve 56 of the head portion 14 of the toothbrush
35 (shown in Figure 2).

Figure 12 shows a mid-position of the movement of the core element where the upper surface of the core element 110 abuts a shoulder portion 180 of fill needle 142. To achieve this mid-position, the core element has moved upwardly within the refilling apparatus, but neither the needle itself nor the seal assembly 144 to which base 141 of fill needle 142 is attached has moved within pump chamber 145. Inlet valve 176 remains closed.

Referring now to Figure 13, further upward movement of the toothbrush will result in further upward movement of core element 110 within the refilling assembly, the core element pushing upwardly against the shoulder portion 180 of fill needle 142. The needle 142, its base section 141 and the seal assembly 144 move upwardly within pump chamber 145, against the action of spring 174, producing a volume 187 between the needle base 141 and the lower end of pump chamber 145. Fluid from the refilling reservoir is drawn into volume 187 by vacuum action through inlet valve 176, which moves upwardly. Volume 187 fills with fluid as needle base 141 and seal assembly 144 move upwardly against the action of spring 174 in pump chamber 145.

Fill needle 142 has spaced openings around its periphery where it joins base portion 141. More particularly, needle 142 joins base portion 141 through a "cross-hair" structure, with the space between the adjacent portions of the cross-hair structure being open to the hollow interior of the needle. When the core element reaches its highest position within the refiller assembly, volume 187 has a capacity of approximately 4 ml, and is completely filled with fluid from the refilling reservoir 111.

At this point, the brushhead is withdrawn slightly. When the brush is withdrawn, the action of spring 174 forces the seal assembly 144, the base portion 141 of the needle and the fill needle 142 itself downwardly with pump chamber 145, decreasing the volume 187. The fluid in volume 187 is forced through the cross-hair openings at the base of the fill needle

down into and through the hollow interior of fill needle 142 and out opening 188 at the lower end of the needle.

Opening 188 in needle 142 at this point is within the refilling valve in the toothbrush, as explained above. Referring to Figures 4A and 4B, needle 142 extends down through a top seal element 189 in the valve 56 to approximately the lower end 190 thereof. The valve 56 seals around the needle 142 in region 193, preventing any backflow of fluid from the needle through outlet port 194, which connects with fluid line 60. Fluid coming out opening 188 in the needle moves through port 192 into fluid line 52 (Figure 3), which leads to the on-board reservoir 50.

The amount of fluid moved from the refilling apparatus into reservoir 50 is approximately 4 milliliters in the embodiment shown, which is the amount of fluid appropriate for one unit-of-use. Other amounts, however, could be dispensed to the on-board reservoir, if desired, depending on the capacity of the reservoir. When the toothbrush is sufficiently withdrawn from the refilling assembly, the needle, its base portion and the seal assembly are back to their original position in the refilling apparatus, as shown in Figure 12. The toothbrush is then removed from the refiller apparatus, ready for a single use of fluid, i.e. a single brushing event. The refilling of the on-board reservoir 50 occurs prior to each brushing.

While the embodiment shown includes a single unit-of-use reservoir, with the reservoir being filled for each brushing, it is possible to modify the reservoir so as to have fluid for more than one use. The external refilling assembly, however, will still be useful for convenient refilling of the reservoir, permitting use of a relatively small fluid reservoir on board the toothbrush, thus saving space and pumping requirements.

Hence, a new fluid-dispensing and refilling system for power toothbrushes has been described. The system includes a small unit-of-use reservoir in a removable head portion of the toothbrush. A fluid line extends from the reservoir to a small

pump element located in the brushhead. The pump element, with the back and forth action of the brushhead, provides movement of the fluid from the reservoir to a dispensing valve in the head of the toothbrush, through which fluid moves to the bristles.

5 The on-board reservoir is refilled before each use by a separate refilling apparatus, into which the toothbrush is inserted. Movement of the brushhead relative to the refilling apparatus in a particular sequence results in fluid in the refiller reservoir moving through a fill needle and refiller
10 valve in the head portion of the toothbrush into the on-board unit-of-use reservoir.

 An alternative embodiment to the pump structure of Figures 5-8 is shown in Figures 15-20. The complete pump, referred to generally at 202, is partially formed within base
15 portion 203 of brushhead 204. A cover member 214 is also part of the complete pump 202. Fluid, such as a dentifrice, is provided to pump 202 through an inlet tube 206. A part of the portion of pump 202 formed in base 203 is a cylindrical pump
20 bore 208. Movable within pump bore 208 is a spherical piston element 210, also referred to as a piston ball.

 Positioned at a discharge end 226 of pump bore 208 is a plug element 212, which has a particular configuration within pump bore 208. A shallow fluid exit section 215 extends from
25 the discharge end 226 of pump bore 208 to a check valve 216, which directs fluid to the bristles. The alternative embodiment of Figures 15-20 is generally more efficient and produces higher pressure than the embodiment previously described.

 Referring now in particular to Figures 15-18, inlet tube 206 provides fluid, such as a dentifrice, through the
30 proximal end 219 of brushhead 204 to a short channel 220 which is molded into the brushhead (Figure 16) and which connects distal end 222 of tube 206 to an inlet connection 224 to pump bore 208 at an inlet end 227. In the embodiment shown, inlet connection 224 is located at the top of pump bore 208.

35 Pump bore 208 in the embodiment shown has a diameter slightly greater than the diameter of the spherical piston

element 210, which in the embodiment shown is 2 mm. It is desirable to have the diameter of the pump bore only slightly greater than the diameter of the piston element 210 so as to maintain pressure within the pump bore and to have very little leakage of fluid past the piston element when the piston element moves within the bore to discharge fluid from the pump bore. In the embodiment shown, the pump bore has a diameter of approximately 2.1 mm and is approximately 4.5 mm long.

Positioned at discharge end 226 of pump bore 208 is plug 212. Plug 212 has an interior surface 232 (facing the pump bore), which is concavely curved, i.e. disc-shaped, as shown most clearly in Figure 20. In the embodiment shown, the curve is slightly greater than the curvature of the spherical piston element. In the embodiment shown, the plug is made from elastomeric material.

In its movement within pump bore 208, the spherical piston element contacts surface 232 at the end of the fluid discharge stroke, during which fluid is pushed from the inlet end of the pump bore to the discharge end by the action of the piston element. In the embodiment shown, the piston element is made from tungsten carbide material. The increased density of tungsten carbide appears to increase the pressure and performance of the pump relative to steel, for instance.

The pump variables affecting performance include the diameter of the spherical piston element, the cross-section area of the spherical piston and the mass of the spherical piston. The clearance between the piston element and the bore also affects performance. The fluid in the pump bore is discharged through outlet 234, located at the top of the discharge end of the pump bore (Figure 20).

Fluid discharged from pump bore 208 moves directly into fluid exit section 215, which in the embodiment shown is approximately 0.25 inches long by 0.10 inches wide and 0.02 inches high, defined in the brushhead and the lower surface 214a of cover element 214. Cover element 214 extends from a point at

the start of channel 220 at tube 206 to a point past end 229 of the fluid exit channel 215.

Referring now to Figure 19, the portion of the fluid exit section defined by the lower surface 214a of cover 214 includes two wing extensions 236 and 238 which extend from the longitudinal side edges of the fluid exit channel toward each other, narrowing the exit channel at that point. The two extensions 236 and 238 are generally triangular in shape and narrow the channel from a width of approximately 0.10 inches to a width of approximately 0.04 inches over a distance of approximately 0.08 inches. The two extensions 236 and 238 in channeling the fluid discharged from the pump bore 208 toward the exit opening in the brushhead act as a fluid diode, providing less resistance to fluid flow in the discharge direction than in the opposing direction. Beyond extensions 236 and 238 is a small element 240 which is located centrally between the two sides of the exit channel and which depends down into the exit channel from the lower surface 214a of the cover. The exit channel terminates with the sides thereof angling inwardly and then meeting in a curved portion.

Molded into base portion 203 of the brushhead directly beneath element 240 is a circular opening 244, which in the embodiment shown is approximately 0.10 inches in diameter. Opening 244 extends through the brushhead, opening onto the surface from which the bristles extend. Positioned in the opening 244 such that it extends away from the brushhead surface, among the bristles, is the exit check valve 216. In the embodiment shown, check valve 216 is wedge-shaped in configuration, as opposed to the duck-bill configuration of Figures 5-8. Overall, as indicated above, the pump embodiment of Figures 15-20 is generally more efficient and produces better pressure than the pump previously disclosed.

Although a preferred embodiment of the invention has been disclosed herein for illustration, it should be understood that various changes, modifications and substitutions may be incorporated in such embodiment without departing from the

spirit of the invention, which is defined by the claims as follows.

What is claimed is:

Claims

1. A fluid delivery system for a power toothbrush, comprising:

reservoir means located within a toothbrush head portion of a power toothbrush, the head portion being removable from a handle portion thereof;

a pump member and associated fluid line for moving fluid from said reservoir means to a brushhead part of the head portion of the toothbrush; and

a dispensing member located in the brushhead, connected to said fluid line, permitting exit of fluid to the vicinity of the bristles, under pressure provided by the pump member.

2. A system of claim 1, including a refilling valve member located externally to said reservoir means, wherein the fluid line connects the reservoir means, the refilling valve, the pump member and the dispensing member.

3. A system of claim 1, wherein the pump member is located in the brushhead part.

4. A system of claim 3, wherein the pump member includes a chamber and a ball which moves within the chamber in response to the movement of the brushhead in operation of the toothbrush, wherein movement of the ball results in fluid moving from the reservoir means into the pump member and then from the pump member to the dispensing member in the brushhead.

5. A system of claim 4, wherein the chamber is cylindrical and extends laterally of the brushhead, and wherein the movement of the brushhead is from side to side.

6. A system of claim 1, wherein the dispensing member is a valve which is positioned in the brushhead such that a free end portion of said valve extends to a point which is above a base

surface of the brushhead, in the midst of bristle portions of the brushhead.

7. A system of claim 6, wherein the free end portion of the valve includes a pair of flexible, normally closed lips which open to permit exit of fluid therefrom when fluid pressure is applied thereto by action of the pump member.

8. A system of claim 1, wherein the pump member is positioned on a base element which includes a channel therein which connects an outlet of the pump member to the dispensing member.

9. A system of claim 1, wherein the reservoir means has a capacity of approximately one unit-of-use of fluid.

10. A system of claim 1, wherein the fluid is a dentifrice.

11. A system of claim 1, wherein the fluid is a selected medication for treatment of an oral medical condition.

12. A system of claim 2, wherein the refilling valve member includes means for receiving a needle from a refilling apparatus and a port connecting to the reservoir means, wherein fluid is moved into the reservoir means from an external source thereof through the needle.

13. A system of claim 12, wherein the refilling valve includes a sealing portion which prevents backflow of fluid from the needle through the refilling valve.

14. A fluid delivery system for a power toothbrush, comprising:

reservoir means located within a toothbrush, the reservoir having a capacity of approximately one unit-of-use of fluid;

a pump member and associated fluid line for moving fluid from said reservoir means to a brushhead part of the toothbrush; and
a dispensing member located in the brushhead, connected to said fluid line, permitting exit of fluid to the vicinity of the bristles, under pressure provided by the pump means.

15. A system of claim 14, wherein the pump member is located in the brushhead.

16. A system of claim 14, wherein the pump member includes a chamber and a ball which moves within the chamber in response to the movement of the brushhead in operation of the toothbrush, wherein movement of the ball results in fluid moving from the reservoir means into the pump member and then from the pump member to the dispensing member in the brushhead.

17. A system of claim 14, wherein the dispensing member is a valve which is positioned in the brushhead such that a free end portion of said valve extends to a point which is above a base surface of the brushhead, in the midst of bristle portions of the brushhead.

18. A pump for use in a fluid delivery system for a power toothbrush, comprising:

a pump member for moving fluid from a reservoir of fluid to a dispensing member located in a brushhead portion of the toothbrush, wherein the pump member includes a chamber and a ball which moves within the chamber in response to movement of the brushhead during operation of the toothbrush, wherein movement of the ball in the chamber results in fluid moving from the reservoir into the pump member and then out of the pump member with sufficient pressure to move the fluid to the dispensing member and then out of the dispensing member.

19. A system of claim 18, wherein the chamber is cylindrical and extends laterally of the brushhead, and wherein the movement of the brushhead is from side to side.

20. A refilling system for a power toothbrush for use with a power toothbrush having an internal reservoir located therein from which fluid in operation is moved to the bristles in the brushhead, the internal reservoir having a small volume, at least one unit-of-use, the refilling system comprising:

an external refilling assembly separate from the power toothbrush, having a fluid reservoir which contains a substantial volume of fluid, at least a plurality of unit-of-use volumes;

means associated with the refilling assembly and the power toothbrush for establishing a fluid path from the refilling assembly to the power toothbrush; and

means for moving fluid through the fluid path from the refilling assembly to the internal reservoir in the power toothbrush.

21. A system of claim 20, including a refilling valve member in the power toothbrush, the valve member including a first connection leading to the reservoir in the toothbrush and a second connection leading to a pump member in the toothbrush.

22. A system of claim 20, wherein the refilling assembly is configured to permit insertion of the toothbrush thereinto in a cooperating relationship, such that when the toothbrush is in a selected relationship within the refilling assembly, said fluid path is established from the refilling assembly to the power toothbrush.

23. A system of claim 21, wherein the refilling assembly includes a refilling needle having an opening at one end thereof for exit of fluid through the refilling valve to the internal reservoir in the power toothbrush and an opening at the other end for receiving fluid from the reservoir in the refilling assembly, and wherein the toothbrush is adapted to fit into the refilling assembly

such that the needle penetrates into the refilling valve when the refilling valve and the toothbrush are in a particular physical relationship.

24. A system of claim 20, wherein the refilling system includes a top member which is movable between two positions, wherein in one position an opening in the top member comes into approximate registry with an opening in a top surface of the remainder of the refilling system, leading to the reservoir therein, so that the reservoir in the refilling system can be conveniently refilled, and wherein in the other position, the opening in the top member is completely out of registry with the opening in the top surface of the remainder of the refilling system.

25. A system of claim 21, wherein the refilling assembly includes a core member which is movable within the refilling assembly, the core member being configured to receive an upper portion of the toothbrush, including the brushhead, such that when pressure is applied to the toothbrush against the core element, the core element moves, resulting first in a hollow needle element in the refilling assembly penetrating into the refilling valve in the toothbrush, and wherein further movement of the brushhead against the core element results in a further movement of the needle within the refilling assembly, the needle having a base portion and a sealing member positioned in a pump chamber portion of the refilling apparatus, wherein fluid moves into the pump chamber and then into the hollow needle as the toothbrush is moved to its highest point into the refilling assembly and then down again, the fluid moving through the needle, the refilling valve and into the toothbrush reservoir.

26. A pump for use in a fluid delivery system for a power toothbrush, comprising:

a pump member for moving fluid provided thereto to a dispensing member, the pump member being adapted so as to be located in a brushhead portion of the toothbrush, wherein the pump member

includes a pump bore chamber and a piston member which moves within the chamber in response to movement of the brushhead during operation of the toothbrush, wherein fluid entering the pump bore chamber moves therealong under the action of the piston member and out a discharge end thereof, the pump member further including a fluid exit channel portion in the brushhead which extends away from the pump bore at the discharge end thereof, the exit channel portion including an opening in the brushhead portion which connects to said dispensing member.

27. An article of claim 26, wherein the pump bore chamber includes a concave surface at the discharge end thereof, the concave surface having approximately the same curvature as that of the piston member, which is ball shaped, wherein the piston member in operation comes into contact with the concave surface at the end of a discharge part of a pumping cycle.

28. An article of claim 27, wherein the concave surface is part of a plug which forms the discharge end of the pump bore.

29. An article of claim 26, including two projections which extend inwardly of the fluid exit channel from opposing longitudinal sides thereof, resulting in a narrowing of the width of the fluid exit channel, located between the discharge end of the pump bore and said opening in the brushhead portion.

30. An article of claim 29, wherein the projections are tapered so that the width of the fluid exit channel decreases gradually over the length of the projections.

31. An article of claim 30, wherein the greatest width of the fluid exit channel is approximately 0.10 inches, and wherein the channel narrows to approximately 0.04 inches between the spaced projections.

32. An article of claim 26, wherein the pump is formed within the brushhead and by a mating cover member.

33. An article of claim 26, wherein the piston element is made from tungsten carbide.

34. A pump for use in a fluid delivery system for an oral care device, comprising:

a pump member for moving fluid provided thereto to a dispensing member, the pump member being adapted so as to be located in a moving end portion of the oral care device, wherein the pump member includes a pump bore chamber and a piston member which moves within the chamber in response to movement of the end portion during operation of the oral care device, wherein fluid entering the pump bore chamber moves therealong under the action of the piston member and out a discharge end thereof, the pump member further including a fluid exit channel portion in the end portion which extends away from the pump bore at the discharge end thereof, the exit channel portion including an opening in the end portion which connects to said dispensing member.

35. An article of claim 34, wherein the pump bore chamber includes a concave surface at the discharge end thereof, the concave surface having approximately the same curvature as that of the piston member, which is ball shaped, wherein the piston member in operation comes into contact with the concave surface at the end of a discharge part of a pumping cycle.

36. An article of claim 35, wherein the concave surface is part of a plug which forms the discharge end of the pump bore.

37. An article of claim 34, including two projections which extend inwardly of the fluid exit channel from opposing longitudinal sides thereof, resulting in a narrowing of the width of the fluid exit channel, located between the discharge end of the pump bore and said opening in the end portion.

38. An article of claim 37, wherein the projections are tapered so that the width of the fluid exit channel decreases gradually over the length of the projections.

39. An article of claim 38, wherein the greatest width of the fluid exit channel is approximately 0.10 inches, and wherein the channel narrows to approximately 0.04 inches between the spaced projections.

40. An article of claim 34, wherein the pump is formed within the end portion and by a mating cover member.

41. An article of claim 34, wherein the piston element is made from tungsten carbide.

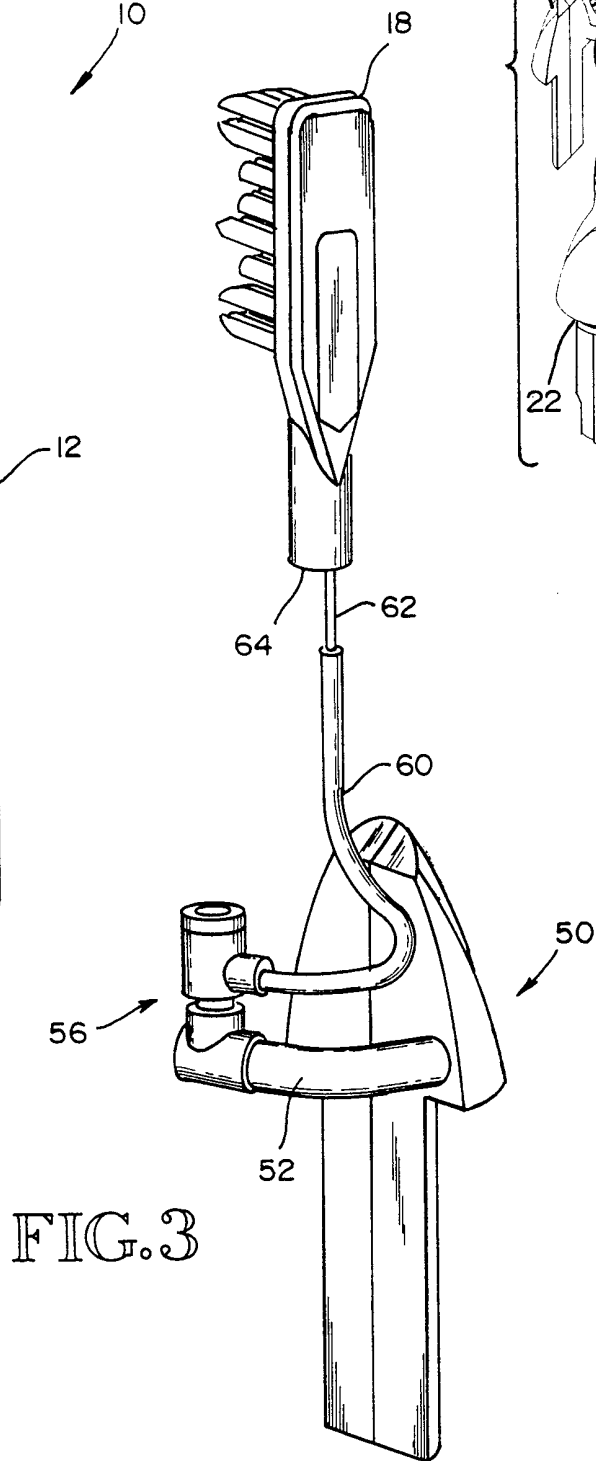
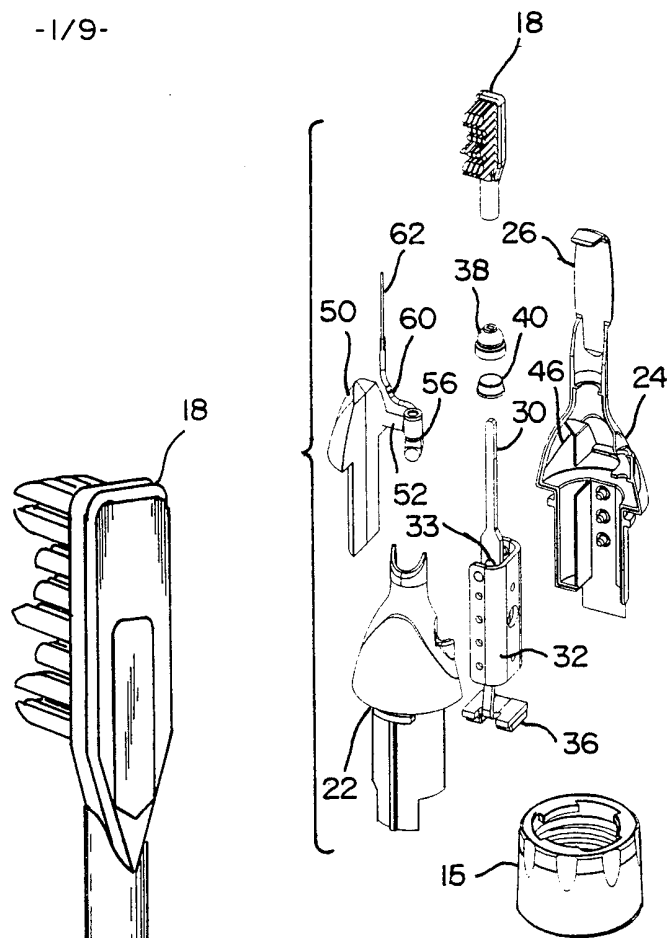
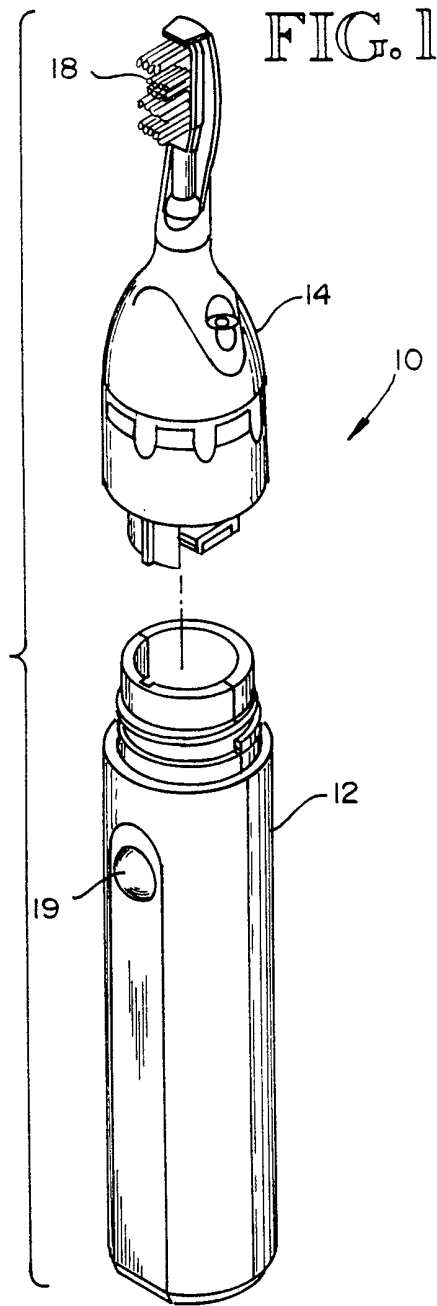

FIG. 4A

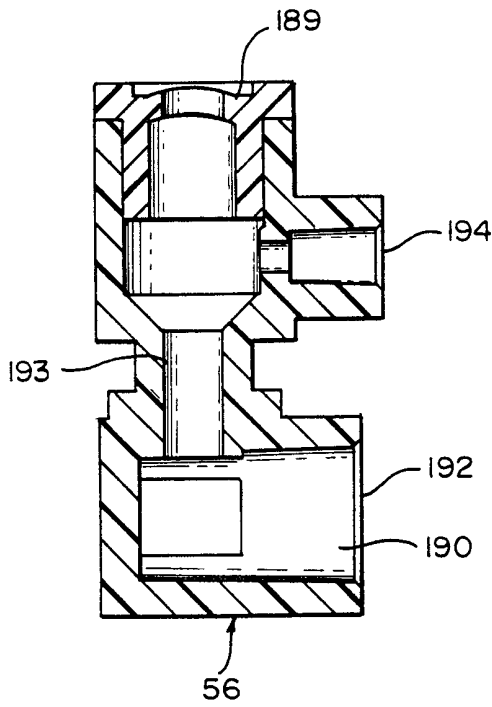

FIG. 4B

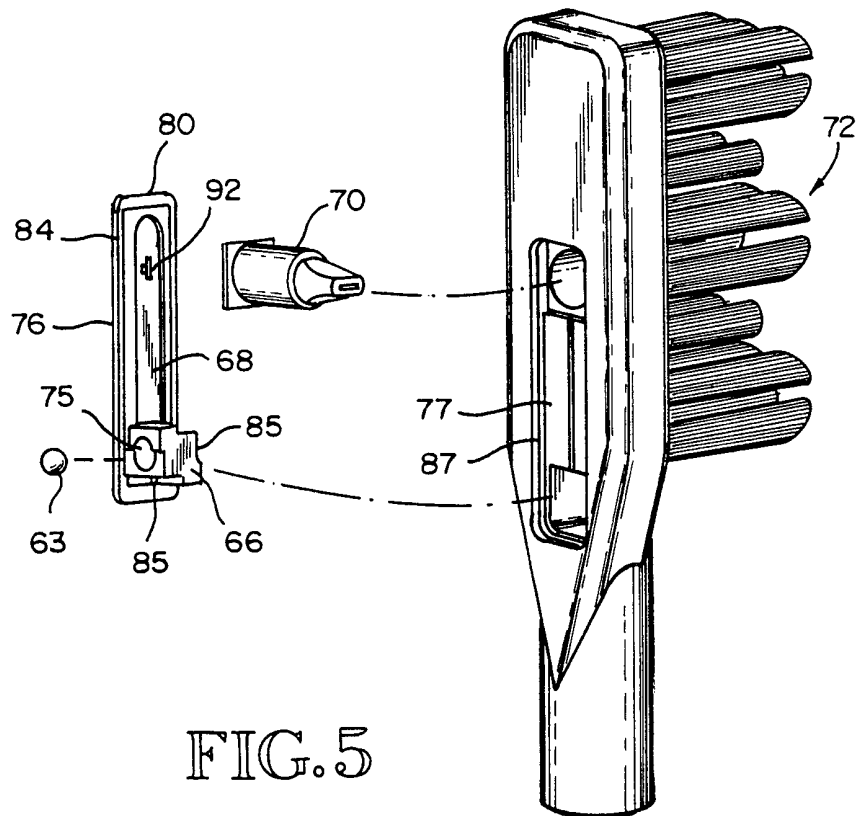
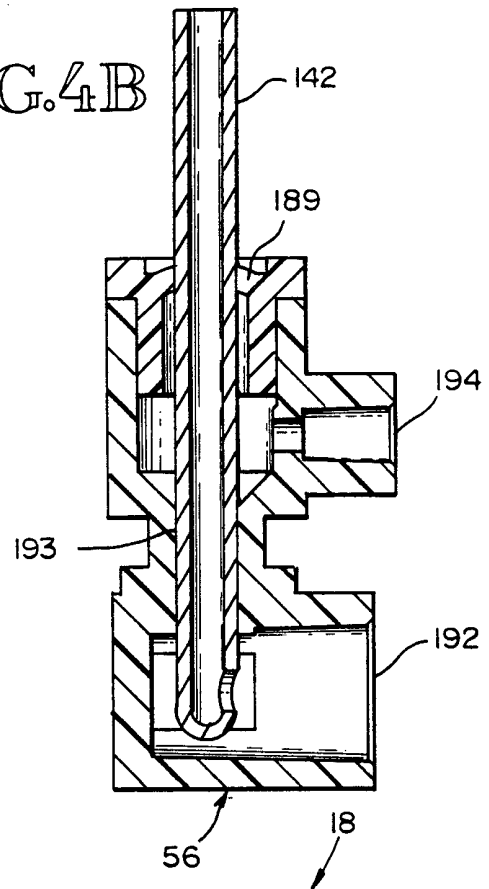
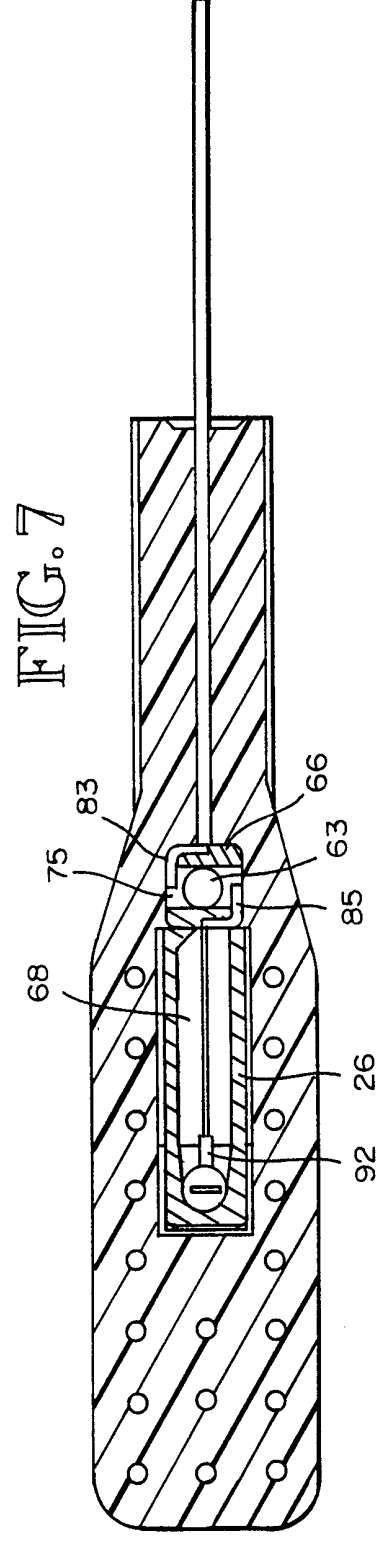
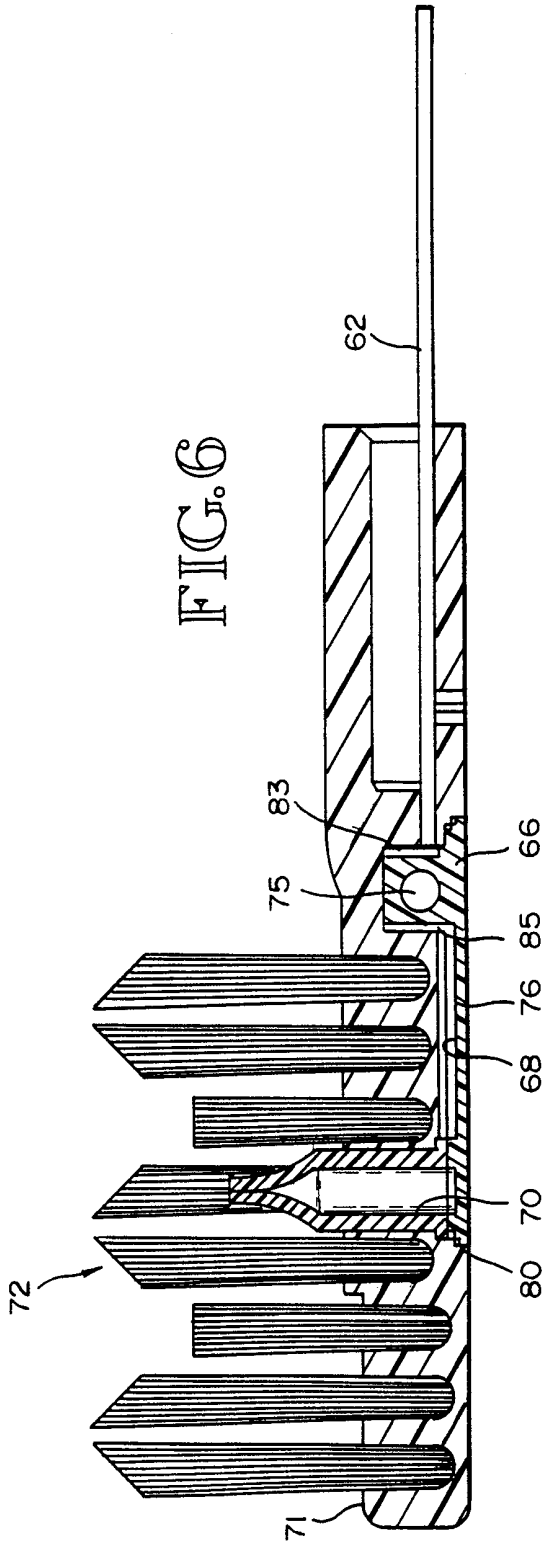
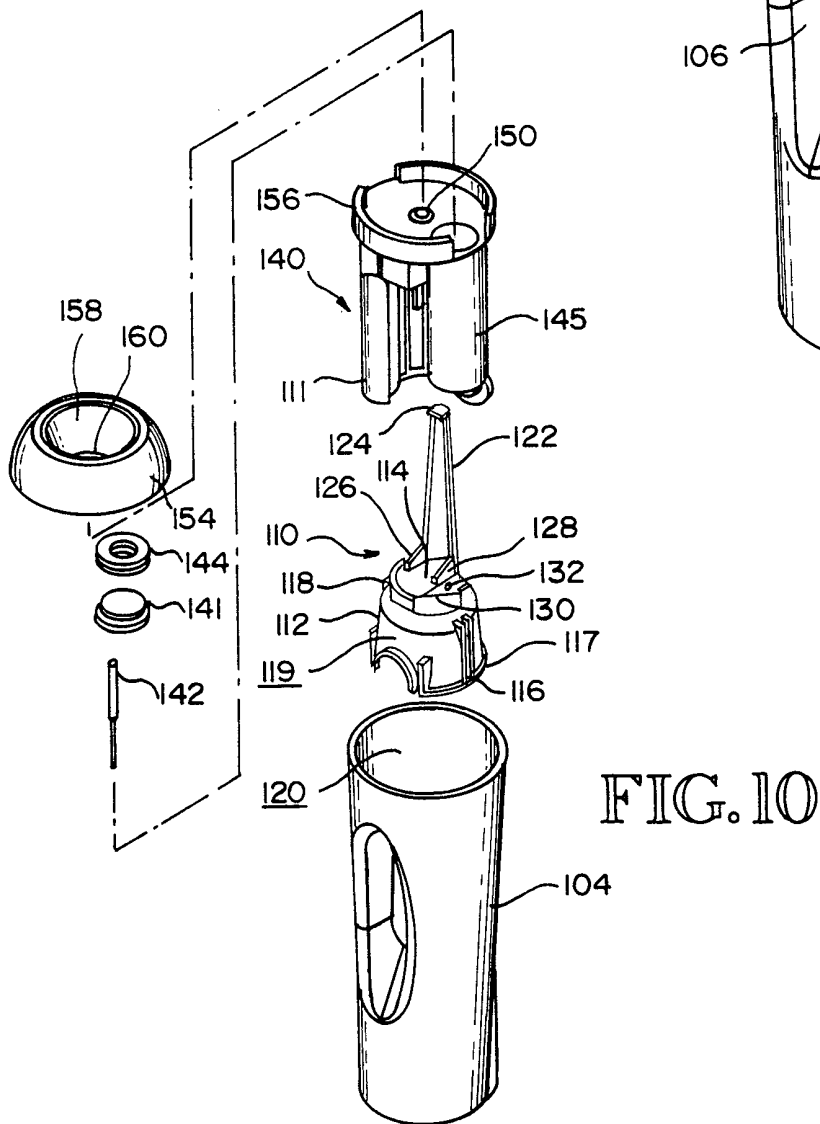
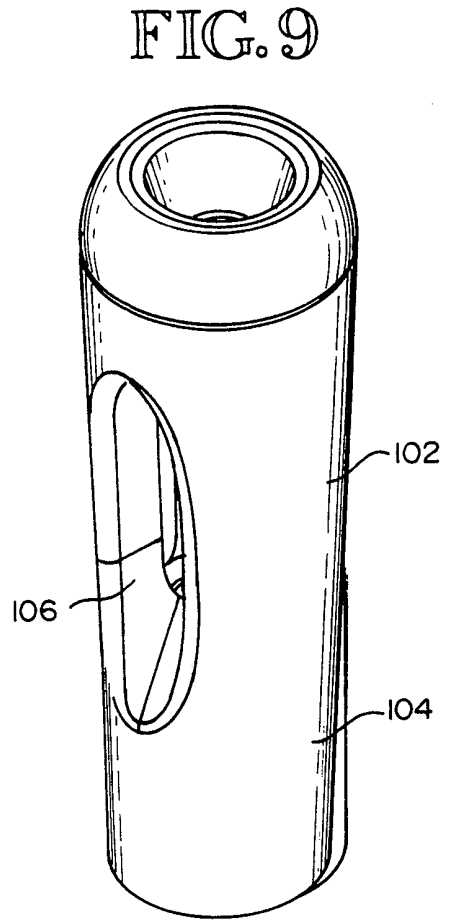
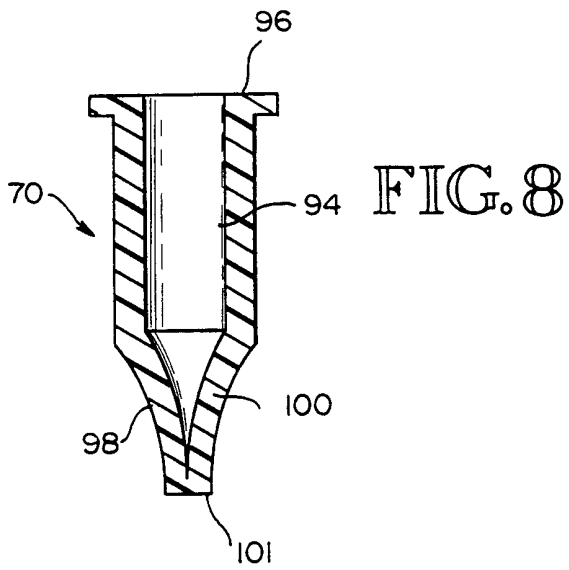

FIG. 5





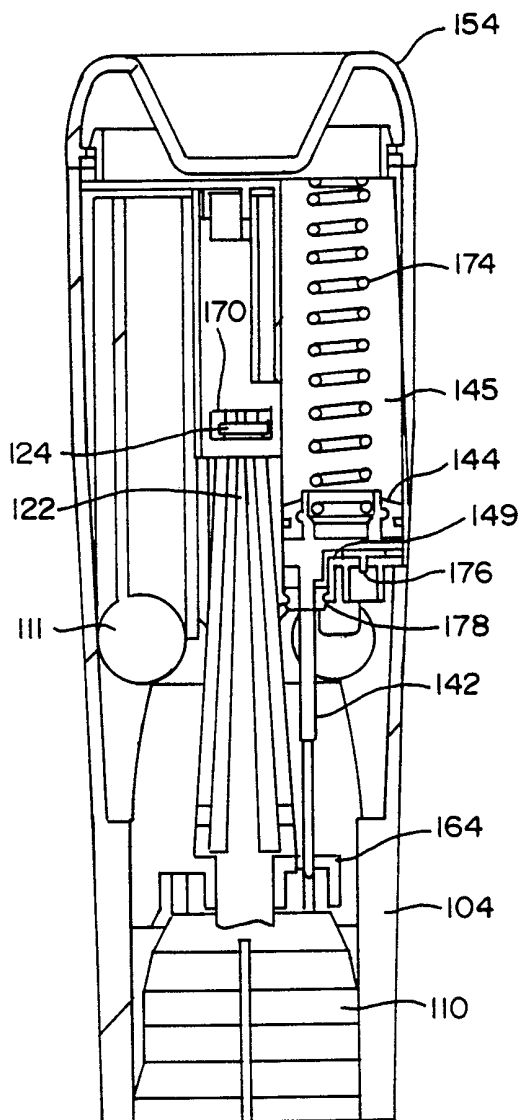

FIG. 11

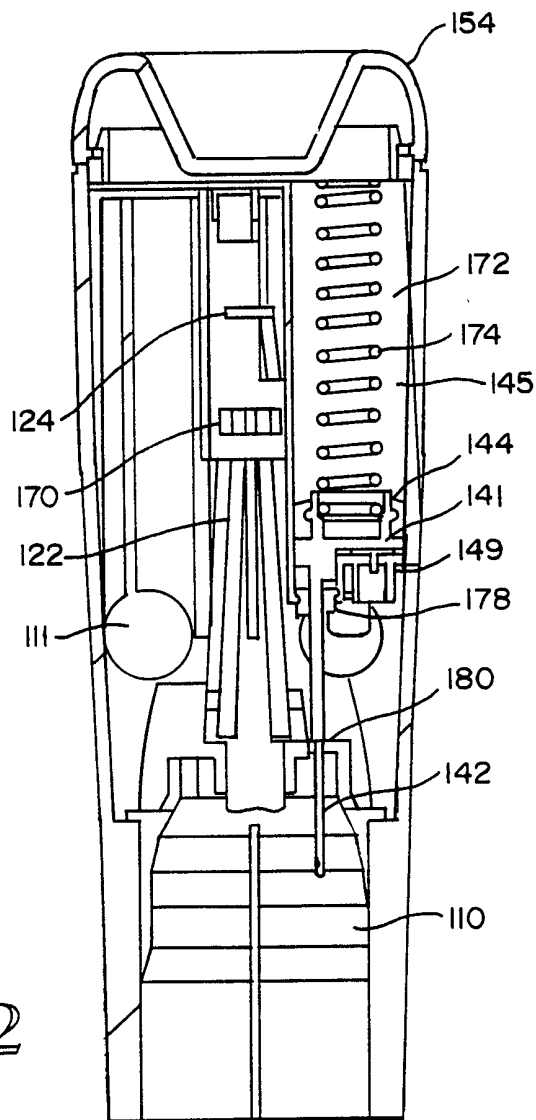

FIG. 12

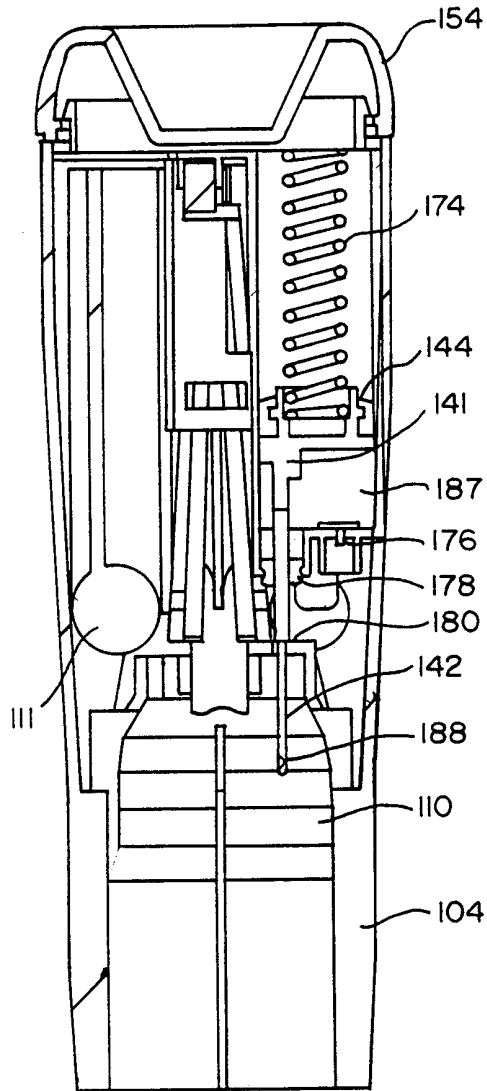
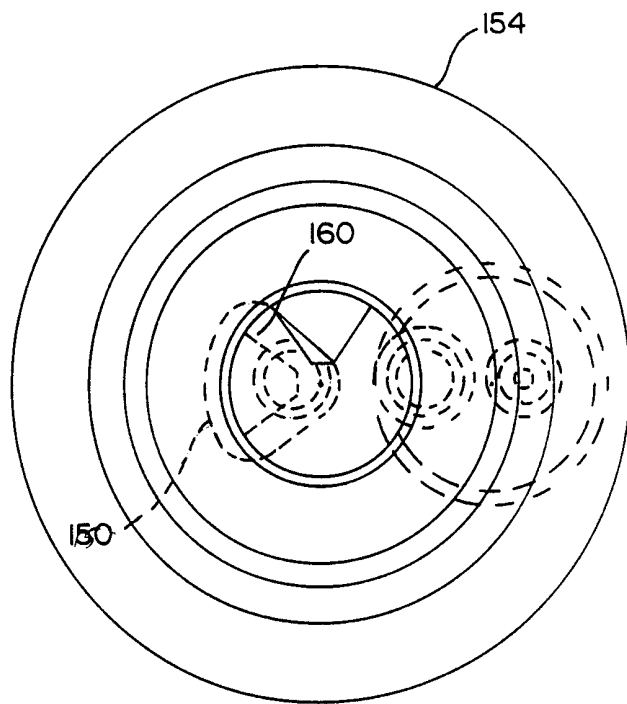
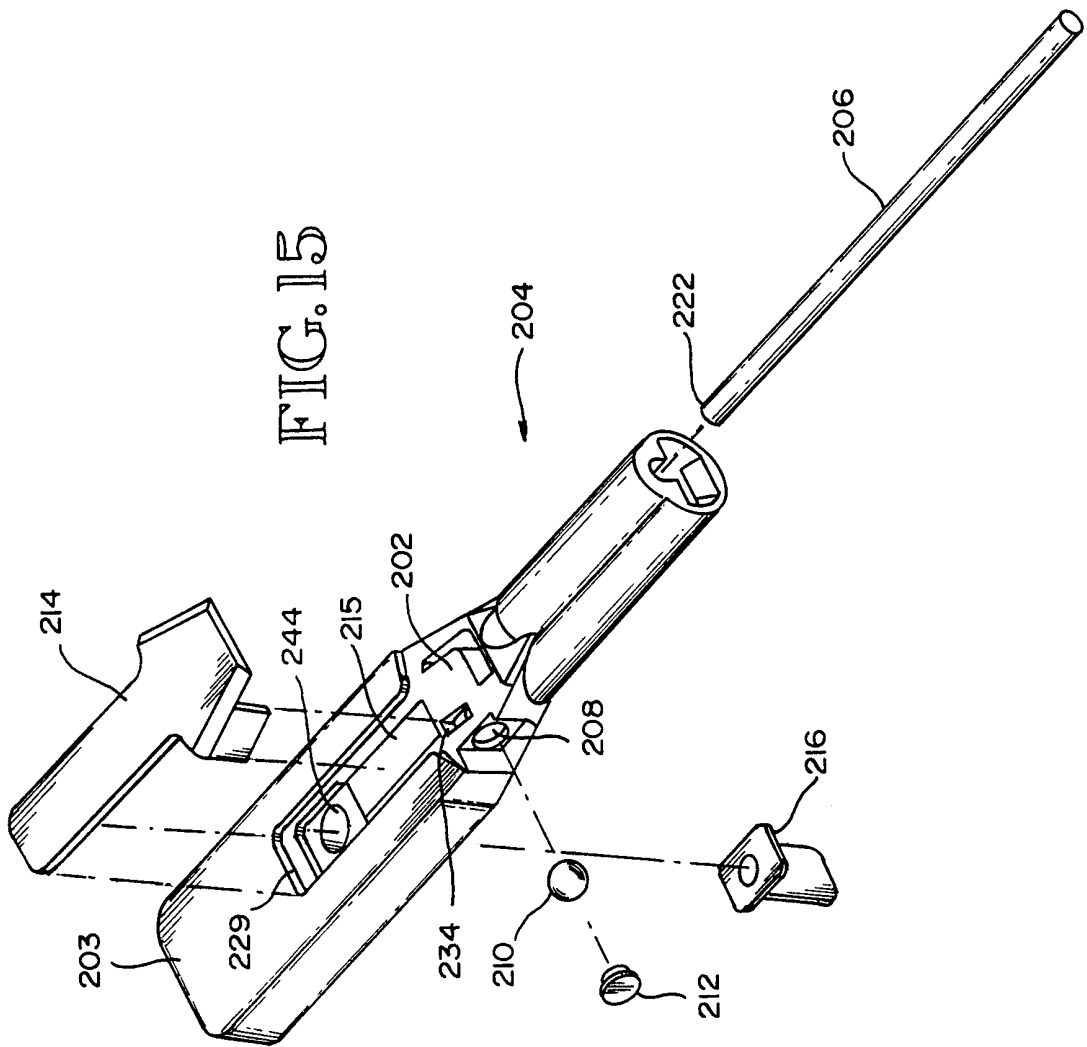

FIG. 13

FIG. 14





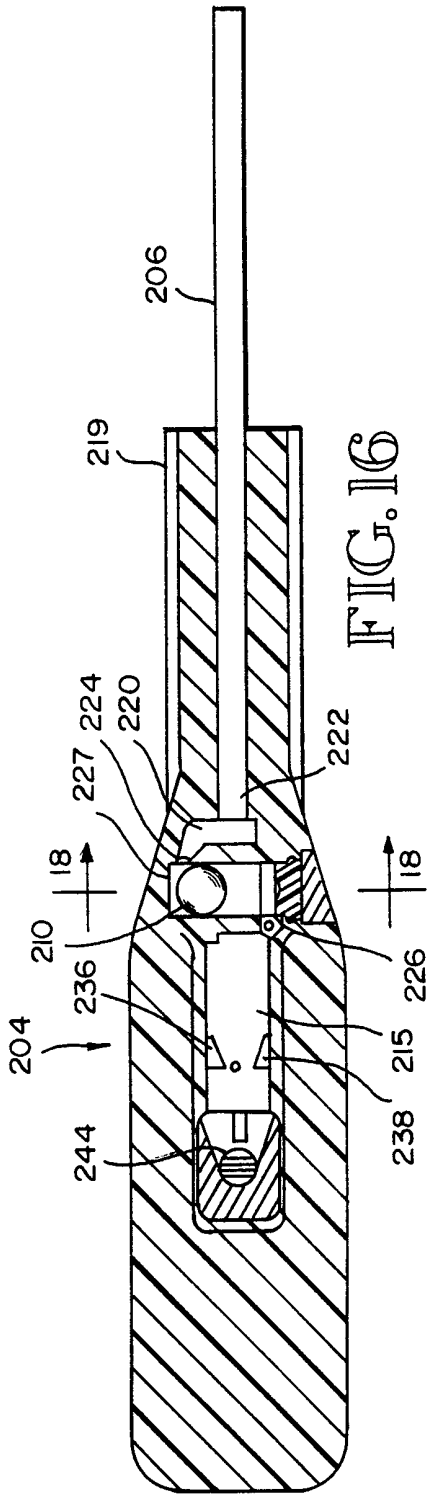

FIG. 16

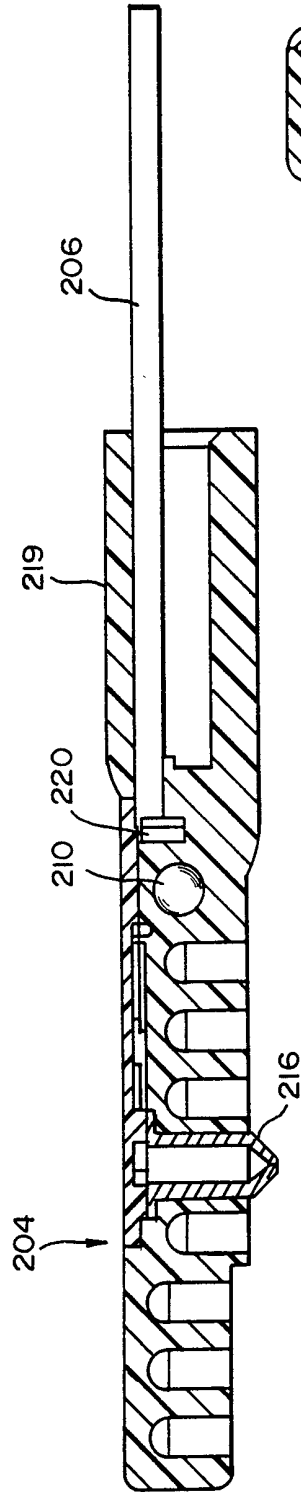

FIG. 17

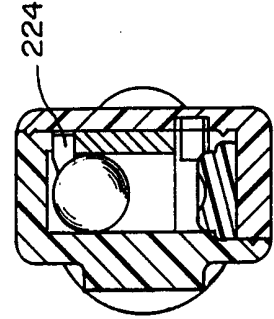
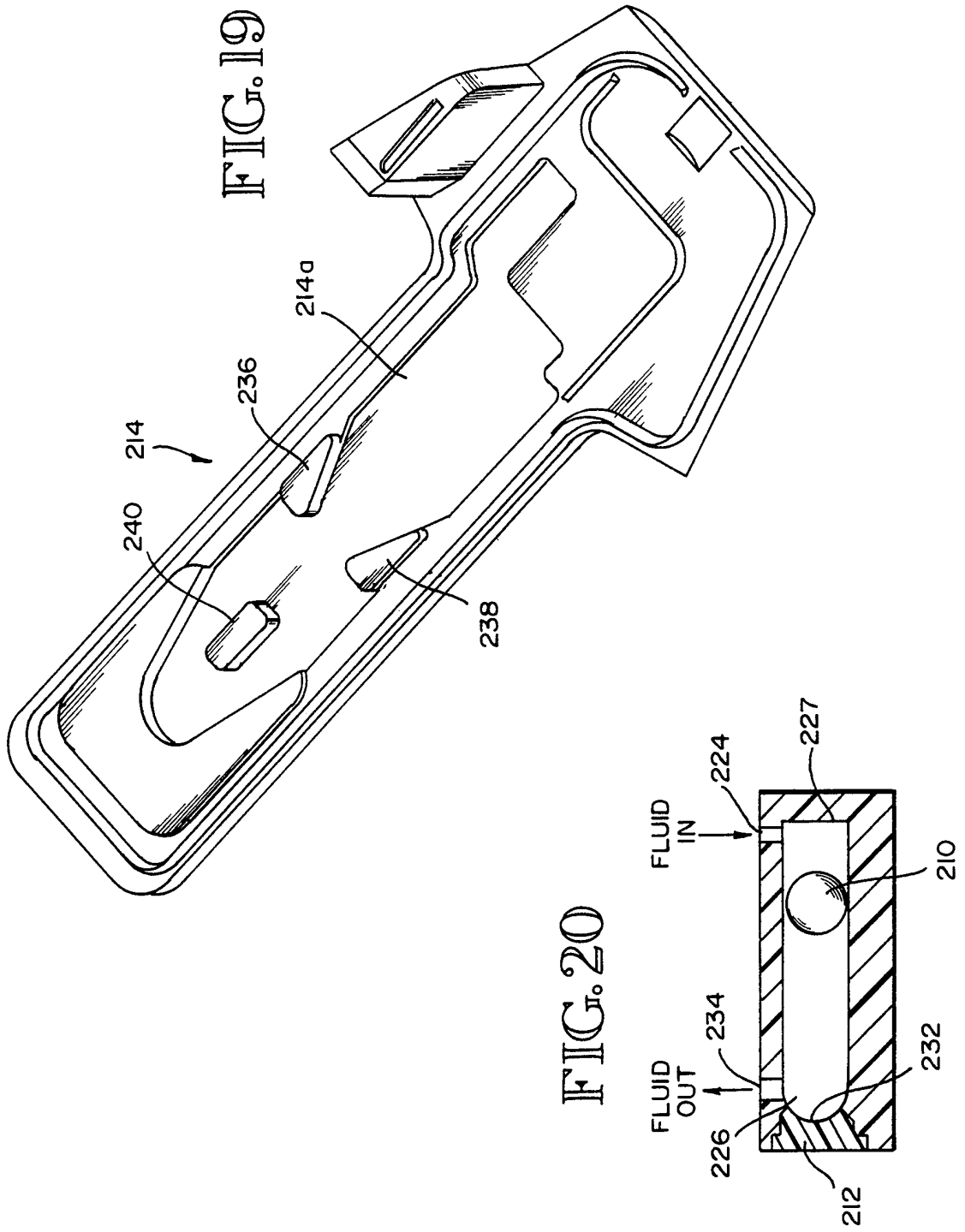

FIG. 18



INTERNATIONAL SEARCH REPORT

International Application No PCT/US 00/00435

A. CLASSIFICATION OF SUBJECT MATTER
 IPC 7 A61C17/36

According to International Patent Classification (IPC) or to both national classification and IPC

B. FIELDS SEARCHED

Minimum documentation searched (classification system followed by classification symbols)
 IPC 7 A61C

Documentation searched other than minimum documentation to the extent that such documents are included in the fields searched

Electronic data base consulted during the international search (name of data base and, where practical, search terms used)

C. DOCUMENTS CONSIDERED TO BE RELEVANT

Category °	Citation of document, with indication, where appropriate, of the relevant passages	Relevant to claim No.
X A	US 3 178 754 A (CLEVERDON) 20 April 1965 (1965-04-20) the whole document	14 1, 6-8, 18, 26, 34
X A	DE 16 32 384 A (BRAUN) 24 June 1971 (1971-06-24) the whole document	14 1, 18, 20, 26, 34
A	GB 2 201 887 A (GOOLD) 14 September 1988 (1988-09-14) the whole document	1, 14, 20
A	US 5 309 590 A (GIULIANI) 10 May 1994 (1994-05-10) cited in the application the whole document	1, 14, 18, 20, 26, 34

Further documents are listed in the continuation of box C. Patent family members are listed in annex.

° Special categories of cited documents :

A document defining the general state of the art which is not considered to be of particular relevance *E* earlier document but published on or after the international filing date *L* document which may throw doubts on priority claim(s) or which is cited to establish the publication date of another citation or other special reason (as specified) *O* document referring to an oral disclosure, use, exhibition or other means *P* document published prior to the international filing date but later than the priority date claimed	*T* later document published after the international filing date or priority date and not in conflict with the application but cited to understand the principle or theory underlying the invention *X* document of particular relevance; the claimed invention cannot be considered novel or cannot be considered to involve an inventive step when the document is taken alone *Y* document of particular relevance; the claimed invention cannot be considered to involve an inventive step when the document is combined with one or more other such documents, such combination being obvious to a person skilled in the art. *&* document member of the same patent family
---------------------------------------------------------------------------------------------------------------------------------------------------------------------------------------------------------------------------------------------------------------------------------------------------------------------------------------------------------------------------------------------------------------------------------------------------------------------------------------------------------------------------------------------------------------	-------------------------------------------------------------------------------------------------------------------------------------------------------------------------------------------------------------------------------------------------------------------------------------------------------------------------------------------------------------------------------------------------------------------------------------------------------------------------------------------------------------------------------------------------------------------------------------------------------------------------------------------------------------------------------------------

Date of the actual completion of the international search 2 June 2000	Date of mailing of the international search report 13/06/2000
-------------------------------------------------------------------------------------	-----------------------------------------------------------------------------

Name and mailing address of the ISA European Patent Office, P.B. 5818 Patentlaan 2 NL - 2280 HV Rijswijk Tel. (+31-70) 340-2040, Tx. 31 651 epo nl, Fax: (+31-70) 340-3016	Authorized officer Vanrunxt, J
----------------------------------------------------------------------------------------------------------------------------------------------------------------------------------------	----------------------------------------------

INTERNATIONAL SEARCH REPORT

Information on patent family members

International Application No

PCT/US 00/00435

Patent document cited in search report	Publication date	Patent family member(s)	Publication date
US 3178754 A	20-04-1965	NONE	
DE 1632384 A	24-06-1971	NONE	
GB 2201887 A	14-09-1988	NONE	
US 5309590 A	10-05-1994	US 5476384 A AT 164993 T AU 660640 B AU 9158591 A CA 2097505 A DE 69129273 D DE 69129273 T EP 0565598 A ES 2114557 T JP 6504924 T WO 9210146 A	19-12-1995 15-05-1998 06-07-1995 08-07-1992 14-06-1992 20-05-1998 17-09-1998 20-10-1993 01-06-1998 09-06-1994 25-06-1992