

(19)



Europäisches Patentamt  
European Patent Office  
Office européen des brevets



(11)

**EP 1 426 505 A2**

(12)

**EUROPEAN PATENT APPLICATION**

(43) Date of publication:  
**09.06.2004 Bulletin 2004/24**

(51) Int Cl.7: **E03D 9/03**

(21) Application number: **03027768.5**

(22) Date of filing: **03.12.2003**

(84) Designated Contracting States:  
**AT BE BG CH CY CZ DE DK EE ES FI FR GB GR  
HU IE IT LI LU MC NL PT RO SE SI SK TR**  
Designated Extension States:  
**AL LT LV MK**

(72) Inventor: **Anselmo, Davide**  
**41051 Castelnuovo Rangone (Prov. Mod.) (IT)**

(74) Representative: **Modiano, Guido, Dr.-Ing. et al**  
**Modiano Gardi Patents,**  
**Via Meravigli, 16**  
**20123 Milano (IT)**

(30) Priority: **05.12.2002 IT mo20020346**

(71) Applicant: **I.G. Incerti Plast S.R.L.**  
**41051 Castelnuovo Rangone,**  
**(Prov. of Modena) (IT)**

(54) **Universal dispenser of sanitizing liquid for containers of water or the like, particularly flushing cisterns for toilets**

(57) A universal dispenser (1) of sanitizing liquid for containers of water or the like, particularly flushing cisterns for toilets, comprising a tank (2) of sanitizing liquid that is associable with a container of water or the like and is provided with an outlet (4) for discharging the liquid into the container, and means (8) for opening and closing the outlet (4), which comprise a flow control element (9) that is associated so that it can move externally with respect to the tank (2) at the outlet and an actuation assembly (10) that is adapted to actuate the flow control element (9) alternately between a closed configuration and an open configuration of the discharge outlet, depending on the level of the water that is present inside the container.

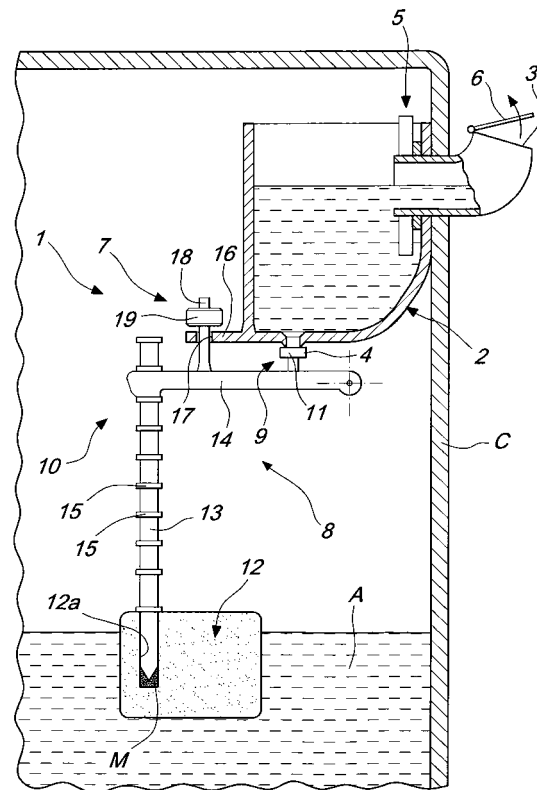

*Fig. 1*

**EP 1 426 505 A2**

## Description

**[0001]** The present invention relates to a universal dispenser of sanitizing liquid for containers of water or the like, particularly flushing cisterns for toilets.

**[0002]** It is known that the need to ensure a good level of hygiene of sanitary facilities both in domestic environments and even more so in public places, such as offices, schools and hospitals, is now rather widespread.

**[0003]** The public has in fact developed particular attention to the cleanliness and healthiness of sanitary facilities, particularly within public buildings, in which the frequent traffic of many users can cause unpleasant situations.

**[0004]** Various systems for sanitizing toilet bowls and for deodorizing their environment are currently used.

**[0005]** For example, tablets are known which contain sanitizing substances that are released upon contact with water.

**[0006]** These tablets, for example, can be inserted directly in the flushing cistern connected to the bowl, so that at each flush the sanitizing substances released upon contact with the water contained in the bowl reach the inside of the bowl.

**[0007]** However, inserting the tablets in the cisterns can be very awkward and complicated, particularly if the cisterns are recessed in a wall or have lids that are fixed by interlocking, by way of threaded elements or other means that have to be removed every time.

**[0008]** Moreover, these tablets have a rather limited duration and need to be replaced frequently.

**[0009]** Finally, the amount of sanitizing substances that a tablet releases into the water of the cistern depends on the time elapsed between one flush and the next, and therefore it is not always constant and adapted to perform a correct sanitizing and deodorizing action.

**[0010]** As an alternative, cages are known which contain the tablets and are applied at the upper rim of the bowl.

**[0011]** However, the placement and replacement of the cages are scarcely hygienic, since the operator is forced to act manually in a region located inside the bowl.

**[0012]** Moreover, rather often the cage falls accidentally into the drainpipe, clogging it and requiring the intervention of an operator to retrieve the cage.

**[0013]** Further, the sanitizing action is limited to the portion of the bowl that lies below the region where the cages are arranged.

**[0014]** Finally, such tablets tend to stain the bowl and their prolonged use can cause an unpleasant colored ring at the level of the water on the bottom of said bowl.

**[0015]** In order to obviate these drawbacks, automatic dispensers for flushing cisterns are also known which are substantially constituted by a tank of sanitizing liquid that is provided with an outlet for said liquid, a discharge tube provided with an upper end that is connected to the outlet and a lower end that is arranged inside a flushing

cistern, a valve for adjusting the flow of sanitizing liquid that exits from the lower end, and an element for closing and opening the lower end that is actuated by the level of the water inside the cistern.

**[0016]** These dispensers are not free from drawbacks, including the fact that during assembly it is necessary to adapt the length and shape of the discharge tube to the dimensions and type of the flushing cistern to which the dispenser is to be applied.

**[0017]** This process entails an increase in the work time required to perform assembly and entails a waste of material, and can be performed only by expert operators.

**[0018]** The aim of the present invention is to eliminate the above-mentioned drawbacks of known dispensers, by providing a universal dispenser of sanitizing liquid for containers of water or the like, particularly flushing cisterns for toilets, that allows to provide faster and simpler assembly operations, to increase the operating flexibility of the dispenser, and to achieve an optimum and prolonged sanitizing action.

**[0019]** Within this aim, an object of the present invention is to provide a universal dispenser of sanitizing liquid for containers of water or the like, particularly flushing cisterns for toilets, that is simple, easy to provide in practice, safe in use, effective in operation, and has a low cost.

**[0020]** This aim and this and other objects that will become better apparent hereinafter are achieved by the present universal dispenser of sanitizing liquid for containers of water or the like, particularly flushing cisterns for toilets, which comprises a tank of sanitizing liquid that is associable with a container of water or the like and is provided with an outlet for discharging said liquid into said container, and means for opening and closing said outlet, characterized in that said opening and closure means comprise a flow control element that is associated so that it can move externally with respect to said tank at said outlet and an actuation assembly that is suitable to actuate said flow control element alternately between a closed configuration and an open configuration of the discharge outlet, depending on the level of the water that is present inside the container.

**[0021]** Further characteristics and advantages of the present invention will become better apparent from the following detailed description of a preferred but not exclusive embodiment of a universal dispenser of sanitizing liquid for containers of water or the like, particularly flushing cisterns for toilets, illustrated by way of nonlimiting example in the accompanying drawings, wherein:

Figure 1 is a partially sectional schematic view of a universal dispenser of sanitizing liquid for containers of water or the like, particularly flushing cisterns for toilets, according to the invention, in the closed configuration;

Figure 2 is a partially sectional schematic view of the dispenser of Figure 1 in the open configuration.

**[0022]** With reference to the figures, the reference numeral 1 generally designates a universal dispenser of sanitizing liquid for containers of water or the like, particularly flushing cisterns for toilets.

**[0023]** In the figures, the dispenser 1 is shown applied to a conventional flushing cistern C, of the type used in conventional sanitary facilities to wash and sanitize toilet bowls.

**[0024]** As an alternative, it is possible to apply the dispenser 1 to any kind of container of water or the like.

**[0025]** The dispenser 1 comprises a tank 2 of sanitizing liquid L that is provided with an intake 3 and with an outlet 4 for discharging the liquid L, which is provided on the bottom of the tank.

**[0026]** The outlet 4 is arranged inside the cistern C, but alternative embodiments of the dispenser 1 in which the outlet 4 is adapted to be placed outside the tank 2 and is connected to the inside of said tank by way of an auxiliary duct or the like, not shown, are not excluded.

**[0027]** In the particular embodiment shown, the tank 2 is advantageously applied inside the cistern C by way of fixing means 5, which are not shown in detail because they are of a conventional type.

**[0028]** In an alternative embodiment of the invention, it is possible to arrange the tank 2 outside the cistern C.

**[0029]** The intake 3 is arranged outside the cistern C and is provided with removable closure means that are constituted for example by a flap 6 that is hinged so as to allow easily to top up the liquid L.

**[0030]** As an alternative, it is possible in any case to provide the intake 3 inside the cistern C.

**[0031]** The dispenser 1 further comprises means 7 for adjusting the quantity of liquid L that exits from the outlet 4 and means 8 for opening and closing said outlet which are accommodated inside the cistern C.

**[0032]** The opening and closure means 8 comprise a flow control element 9, which is movably associated below the tank 2 at the outlet 4, and an actuation assembly 10, which is adapted to actuate the flow control element alternately between a closed configuration and an open configuration of the outlet 4, depending on the level of the water A inside the cistern C.

**[0033]** Advantageously, the height of the actuation assembly 10 can be adjusted so as to adapt to the geometry and dimensions of the cistern C and therefore of the level of water A contained therein.

**[0034]** It is noted in fact that the dispenser 1 can be fitted easily to any type of cistern C currently commercially available, such as conventional models with 6- or 9-liter capacity.

**[0035]** Every time the cistern C flushes, the flow control element 9, moved by way of the actuation assembly 10, passes from the closed configuration to the open configuration and then returns to the closed configuration when the level of the water A inside the cistern C has returned to the initial level.

**[0036]** Figure 1 illustrates the dispenser 1 in the closed configuration; Figure 2 illustrates the dispenser

1 in the open configuration.

The flow control element 9 comprises a sealing gasket 11 that prevents losses of liquid L from the tank 2 in the closed configuration.

**[0037]** The actuation assembly 10 comprises a floating body 12, an actuation rod 13 that is monolithically associated with said body, and an arm 14 for supporting the flow control element 9 that has a first end that is articulated below the tank 2 and a second end that protrudes with respect to the tank and is associated with the rod 13.

**[0038]** The body 12 is designed to be immersed at least partially in the water A contained within the cistern C.

**[0039]** In the closed configuration, the rod 13 is arranged substantially vertically and the arm 14 is arranged substantially horizontally.

**[0040]** Advantageously, the rod 13 is provided with a plurality of annular abutments 15, which are distributed with a constant spacing along its length.

**[0041]** The rod 13 has a lower end that is contoured and accommodated in a corresponding hole 12a formed in the body 12; however, alternative embodiments of the fixing of the rod 13 to the body 12 are not excluded.

**[0042]** During assembly, it is possible to introduce on the bottom of the hole 12a adhesive material M that facilitates the bonding between the body 12 and the rod 13.

**[0043]** The second end of the arm 14 is shaped so as to form a sort of C-shaped portion and can engage by snap action the rod 13 between two consecutive abutments 15.

**[0044]** It is noted that the rod 13 can be used regardless of the dimensions of the cistern C, of the level of the water A inside it, and of the level at which the tank 2 is arranged with respect to said level.

**[0045]** During assembly, it is in fact sufficient to determine, as a function of the geometric and manufacturing factors cited above, at which abutments 15 the rod 13 and the arm 14 are to be assembled, so that the body 12 is immersed in the water A up to the upper surface at the closed configuration.

**[0046]** The adjustment means 7 comprise a bracket-like tab 16, which is formed monolithically with the tank 2 or as an alternative is fixed thereto and is arranged above the arm 14 and provided with a through slot 17.

**[0047]** The adjustment means 7 further comprise a threaded pivot 18 that in the particular embodiment shown is formed monolithically with the arm 14 and is arranged at right angles to said arm; as an alternative, the pivot 18 can be fixed to the arm 14, for example by way of mechanical means, welding or other methods.

**[0048]** The pivot 18 is inserted with play in the slot 17 and has a portion that protrudes upward with respect to the tab 16.

**[0049]** Finally, the adjustment means 7 comprise a threaded ring 19, which is associated with the protruding portion of the pivot 18 and is adapted to abut in an upper

region against the tab 16 in the open configuration.

**[0050]** In the closed configuration, the flow control element 9 seals the outlet 4 by way of the action of the hydrostatic thrust that the body 12 transmits to the flow control element by way of the rod 13 and the arm 14.

**[0051]** In the open configuration, i.e., when the level of the water A decreases inside the cistern C, the body 12 descends for a first extent, entraining the rod 13 and the arm 14 with it, the arm rotating with respect to the tank 2, until the ring 19 abuts against the tab 16.

**[0052]** Conveniently, by varying the level of the ring 19 with respect to the arm 14 it is possible to perform fine adjustment of the quantity of liquid L that exits from the tank 2, adapting the delivery to the different viscosities of the various types of liquid L contained in the tank 2. This adjustment can be performed easily and quickly even after fitting the dispenser 1 to the cistern C.

**[0053]** In an alternative embodiment of the invention, not shown in the figures, it is possible to provide adjustment means 7 that are constituted by a slot formed in the arm 14, a pivot that is monolithically associated with the bottom of the tank 2, is inserted with play in said slot and is provided with a portion that protrudes downward with respect to the arm 14 and a ring that is associated with the protruding portion of said pivot and is adapted to abut below the arm 14 in the open configuration.

**[0054]** In this case also, the ring and the pivot might be threaded in order to facilitate the actions for adjusting the quantity of liquid L that exits from the tank 2.

**[0055]** In practice it has been found that the described invention achieves the intended aim and objects.

**[0056]** In particular, it is noted that the application of the dispenser according to the invention to flushing cisterns ensures complete sanitization of the bowls; moreover, the stream of water and sanitizing liquid that strikes the inside walls of said bowls allows to achieve a significant slowing in the forming of deposits and scale.

**[0057]** The invention thus conceived is susceptible of numerous modifications and variations, all of which are within the scope of the appended claims.

**[0058]** All the details may further be replaced with other technically equivalent ones.

**[0059]** In practice, the materials used, as well as the shapes and the dimensions, may be any according to requirements without thereby abandoning the scope of the protection of the appended claims.

**[0060]** The disclosures in Italian Patent Application No. M02002A000346 from which this application claims priority are incorporated herein by reference.

**[0061]** Where technical features mentioned in any claim are followed by reference signs, those reference signs have been included for the sole purpose of increasing the intelligibility of the claims and accordingly, such reference signs do not have any limiting effect on the interpretation of each element identified by way of example by such reference signs.

## Claims

1. A universal dispenser of sanitizing liquid for containers of water or the like, particularly flushing cisterns for toilets, comprising a tank of sanitizing liquid that is associable with a container of water or the like and is provided with an outlet for discharging said liquid into said container, and means for opening and closing said outlet, **characterized in that** said opening and closure means comprise a flow control element that is associated so that it can move externally with respect to said tank at said outlet and an actuation assembly that is adapted to actuate said flow control element alternately between a closed configuration and an open configuration of said discharge outlet, depending on the level of water that is present inside said container.
2. The dispenser according to claim 1, **characterized in that** it comprises means for adjusting the amount of liquid that exits from said outlet.
3. The dispenser according to one or more of the preceding claims, **characterized in that** said actuation assembly comprises a floating body, an actuation rod that is associable with said floating body, and an arm for supporting said flow control element that is articulated to said tank and is associable with said rod.
4. The dispenser according to one or more of the preceding claims, **characterized in that** said rod comprises a plurality of abutments distributed along its length.
5. The dispenser according to one or more of the preceding claims, **characterized in that** said abutments are substantially annular.
6. The dispenser according to one or more of the preceding claims, **characterized in that** said rod comprises an end that can be fixed in a corresponding hole formed in said floating body.
7. The dispenser according to one or more of the preceding claims, **characterized in that** said arm comprises a contoured portion that can engage by snap action on said rod between two consecutive said abutments.
8. The dispenser according to one or more of the preceding claims, **characterized in that** said outlet is formed on the bottom of said tank and said arm is arranged below said bottom or lies outside said tank.
9. The dispenser according to one or more of the preceding claims, **characterized in that** said adjust-

ment means comprise a bracket-like tab that is associated with said tank at said arm and is provided with a through slot, a pivot that is associated monolithically with said arm, is inserted with play in said slot and has a portion that protrudes above said tab, and a ring that is associated with the protruding portion of said pivot and is adapted to abut in an upper region with respect to said tab in said open configuration.

5

10

10. The dispenser according to one or more of claims 1 to 8, **characterized in that** said adjustment means comprise a through slot formed in said arm, a pivot that is associated monolithically with said tank, is inserted with play in said slot and has a portion that protrudes below said arm, and a ring that is associated with the protruding portion of said pivot and is adapted to abut in a lower region with respect to said arm in said open configuration.

15

20

11. The dispenser according to one or more of the preceding claims, **characterized in that** said pivot and said ring are threaded.

12. The dispenser according to one or more of the preceding claims, **characterized in that** said flow control element comprises at least one sealing gasket.

25

13. The dispenser according to one or more of the preceding claims, **characterized in that** said tank can be accommodated inside said container.

30

14. The dispenser according to one or more of claims 1 to 12, **characterized in that** said tank can be accommodated outside said container.

35

15. The dispenser according to one or more of the preceding claims, **characterized in that** said tank comprises an intake provided with removable closure means.

40

16. The dispenser according to one or more of the preceding claims, **characterized in that** said intake can be arranged outside said container.

45

17. The dispenser according to one or more of claims 1 to 15, **characterized in that** said intake is arranged inside said container.

18. The dispenser according to one or more of the preceding claims, **characterized in that** said rod is adapted to allow the correct positioning of said floating body regardless of the dimensions and geometry of said container and regardless of the level of water that is present in said container.

50

55

19. The dispenser according to one or more of the preceding claims, **characterized in that** said adjust-

ment means are adapted to allow correct dispensing of liquid in output from said tank independently of the degree of viscosity of said liquid.

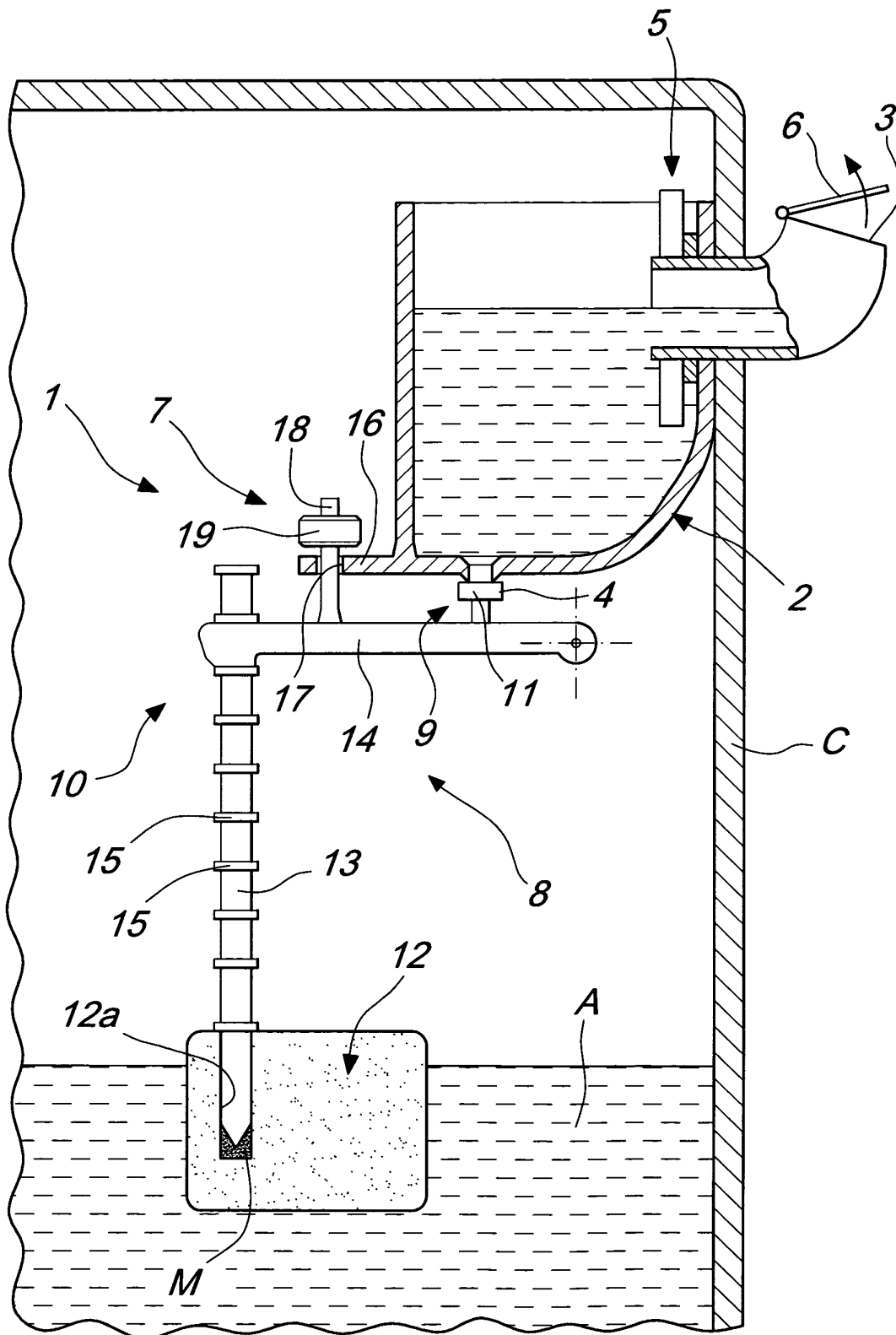

Fig. 1

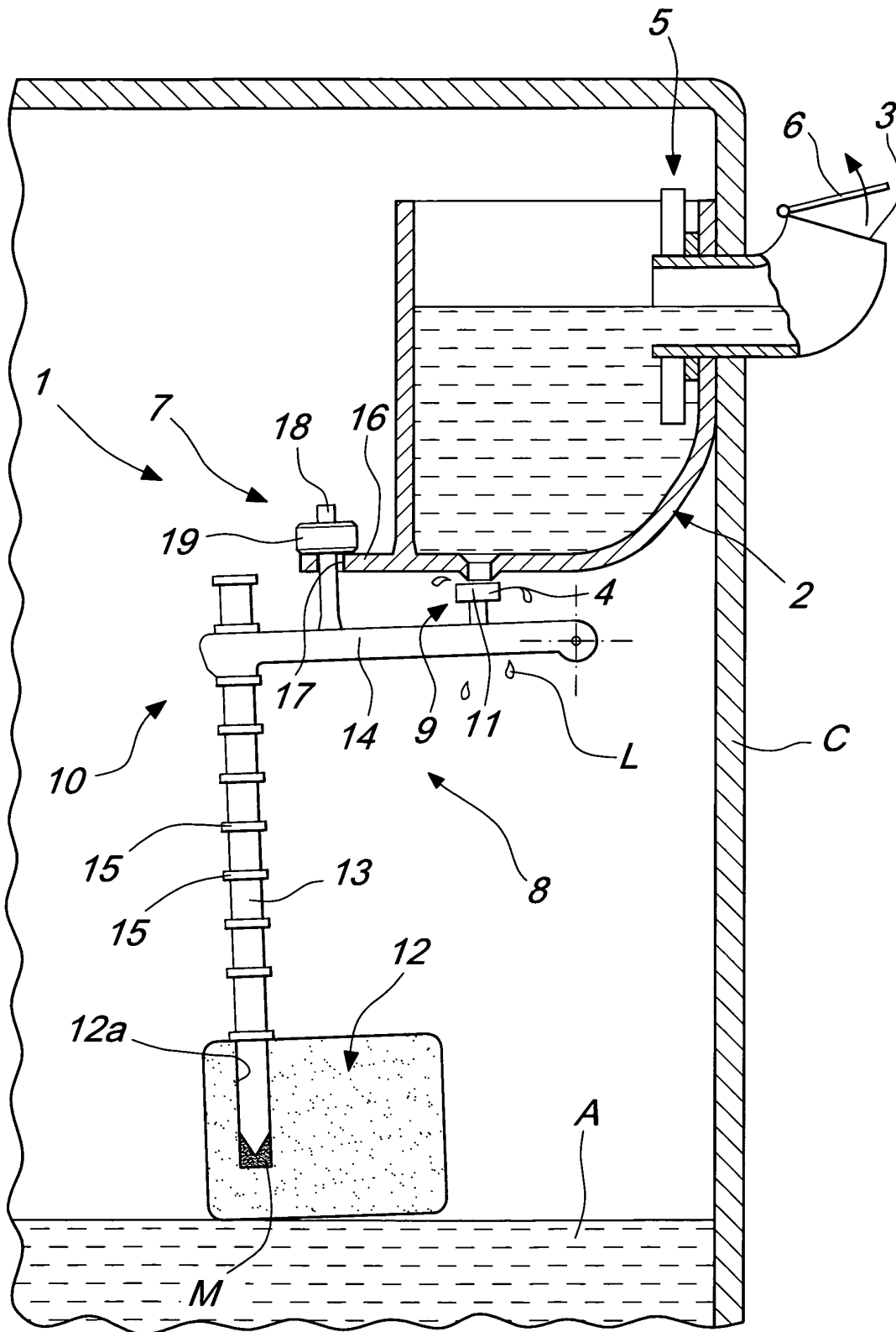

Fig. 2