

A. E. VANCE & O. C. MORTRUDE.
 COPY HOLDER AND DISPLAY APPARATUS.
 APPLICATION FILED MAR. 27, 1913.

1,166,869.

Patented Jan. 4, 1916.

2 SHEETS—SHEET 1.

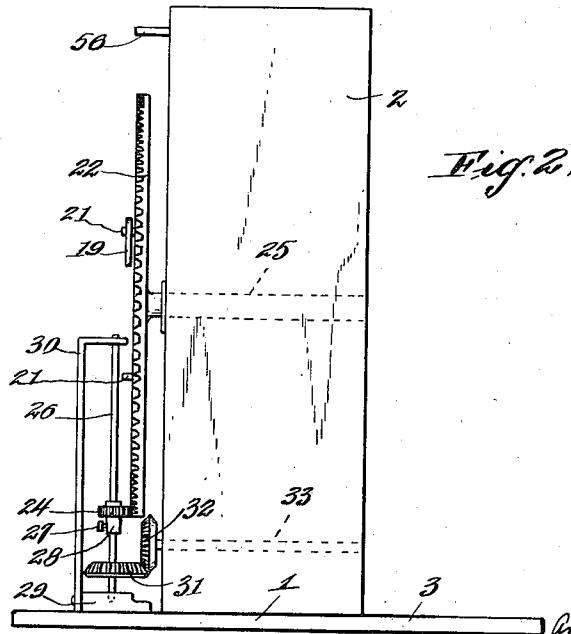
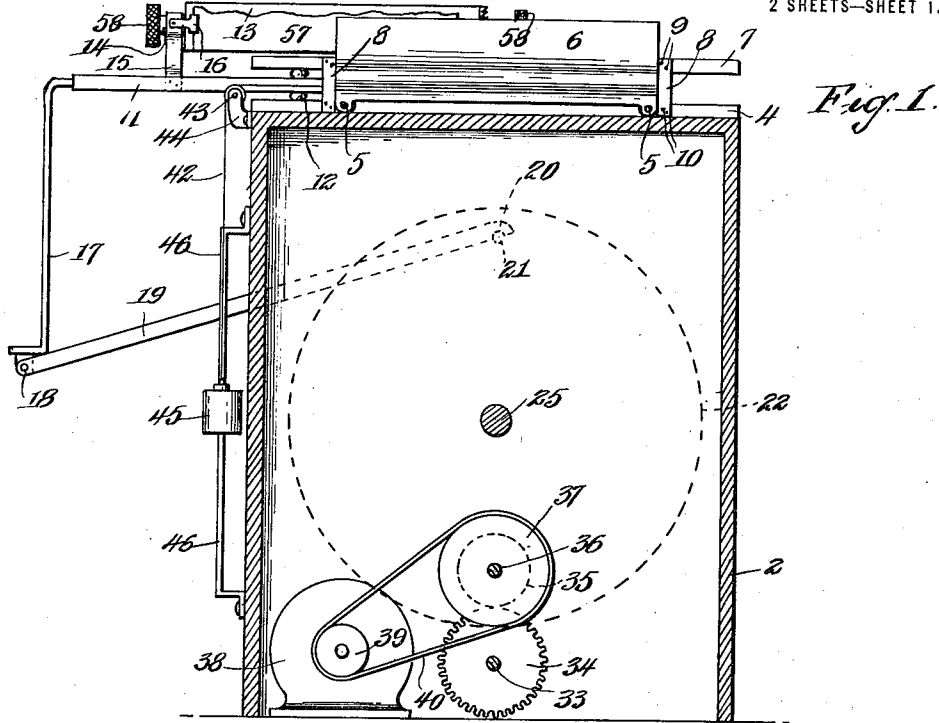

WITNESSES
Wm. E. Walker
M. C. Jones

INVENTORS
Arthur C. Vance
Olive C. Mortrude
 By *John* Attorney

A. E. VANCE & O. C. MORTRUDE.
 COPY HOLDER AND DISPLAY APPARATUS.
 APPLICATION FILED MAR. 27, 1913.

1,166,869.

Patented Jan. 4, 1916.

2 SHEETS—SHEET 2.

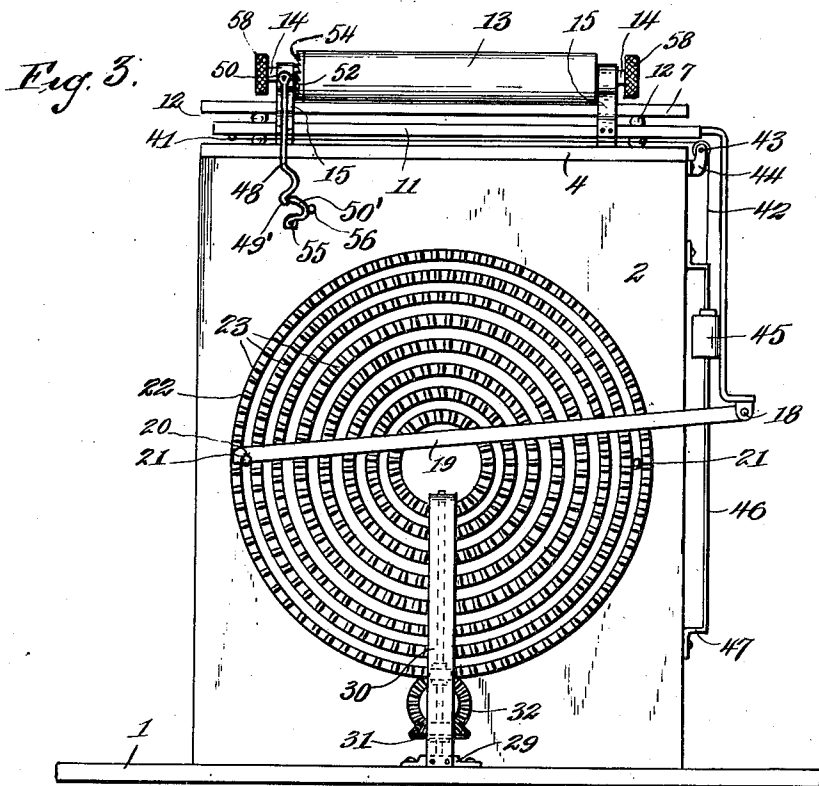

Fig. 4.

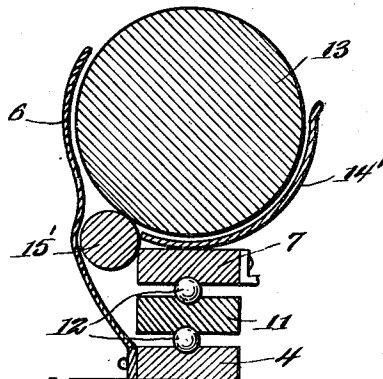

Fig. 5.

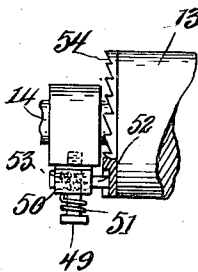
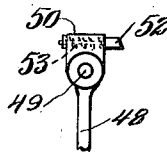

Fig. 6.



WITNESSES

Wm. E. Vack, Jr.
Wm. E. Vack, Jr.

INVENTOR

Andrew E. Vance,
Olivier C. Mortrude,
 By their Attorney
Richard D. Owen.

UNITED STATES PATENT OFFICE.

ANDREW E. VANCE AND OLIVER C. MORTRUDE, OF SIOUX CITY, IOWA.

COPY HOLDER AND DISPLAY APPARATUS.

1,166,869.

Specification of Letters Patent.

Patented Jan. 4, 1916.

Application filed March 27, 1913. Serial No. 757,205.

To all whom it may concern:

Be it known that we, ANDREW E. VANCE and OLIVER C. MORTRUDE, citizens of the United States, residing at Sioux City, in the county of Woodbury and State of Iowa, have invented certain new and useful Improvements in Copy Holders and Display Apparatus, of which the following is a specification.

Our invention relates to a copy-holder and display apparatus, and especially to a device of this kind used in the teaching of the art of typewriting or in the acquiring of greater speed in operating the keys of the typewriting machine.

We have found that the art of typewriting can be taught to better advantage by the use of copy means that move or travel while the student or typist is operating the typewriting machine; and to still better advantage when a shield as set forth hereinafter, is employed in connection with the movable copy means.

Various advantages are gained through the use of the copy-holder employing movable copy means as referred to. A device employing such means forms the basis of this application, and the various advantages and functions will be set forth at length hereinafter.

One object of the invention is to provide in a copy-holder, means whereby the copy being duplicated or copied, may be positively moved or will travel while the typist is operating the typewriting machine.

Another object of the invention is to provide a shield in connection with the said copy-holder means.

Still another object of the invention is to provide means whereby the speed at which the holder means travels, may be regulated or gaged according to the speed at which the operator or typist is operating the typewriting machine.

A further object of the invention is to provide the holder means in the form of a slidable carriage and means to positively slide or shift the carriage.

A still further object of the invention is to provide suitable escapement means for the platen or roller employed on the carriage which will be operated by suitable parts during the travel or sliding movement of the carriage.

Various other objects will appear hereinafter from the description following taken

in connection with the accompanying drawings.

In said drawings:—Figure 1 is a view mostly in front elevation, but showing the casing or housing broken away to expose the driving mechanism thereof; Fig. 2 is a side elevation of the housing and gearing mechanism attached thereto; Fig. 3 is a rear elevation; Fig. 4 is an enlarged detail view through the carriage parts, and shield employed in connection therewith; Fig. 5 is a detail plan view illustrating the escapement mechanism; and Fig. 6 is a detail view of part of the escapement lever specifically showing the mounting of the pawl thereon.

Throughout the views of the drawings, like reference characters designate like or similar parts.

Referring specifically to the drawings, 1 designates a base and 2 designates a casing or housing supported thereon. The base member, it will be seen by reference to Fig. 2, projects beyond the front of the housing as at 3 to provide a portion upon which a typewriting machine may rest or be supported. This base 1 also projects rearwardly beyond the casing in order to support gearing, as will be hereinafter described.

Upon the top of the casing 2 is rigidly fastened a grooved plate or bearing member 4 to which is rigidly fastened as by set screws at 5, a suitably shaped and sized shield designated 6, and which it will be noted rises from the bearing member.

Directly over and distanced from the grooved bearing plate member 4 is a similar grooved bearing plate member 7 which may be supported in proper position in any suitable manner, and as shown is supported by the brackets 8 which are suitably fastened as at 9 and 10 respectively to the several bearing members. Intermediate the bearing members 4 and 7 is slidably mounted a grooved bearing member or bar 11. Balls or other anti-friction members 12 are preferably mounted in the grooves of the bearings 4—7 and 11 in order to reduce friction between these parts. This bearing member 11 forms part of a carriage adapted to move a copy and whose principal part is a turnable roller or platen 13. The shaft or shafts 14 of the platen or roller are mounted in bearing members 15 rising from and fastened to the bar 11. In connection with the platen or roller, a guide shield 14' may be employed, and also a guide and feed

roller 15' may be employed. This shield and roller are seen in Fig. 4. In connection with the platen, guide fingers or members of any suitable type as suggested at 16, are preferably desirable.

To the bar or bearing member 11 is rigidly fastened an arm 17 to which is pivoted as at 18, a pitman or arm 19 whose inner end is provided with a notch or formed into a hook as at 20. This notch or hook at different times is adapted to engage projections or pins 21 which are mounted upon a drive disk 22 on opposite sides of the axis thereof and in diametric alinement. This drive disk is provided with a plurality of annular racks 23 each having teeth as shown. The rack teeth are adapted to mesh with the teeth of a slidable pinion designated 24. The several racks, it will be noted, are arranged concentric with the axis of the disk and of course are of different diameters; hence the speed at which the disk is driven can be regulated by shifting the pinion 24 into engagement with the teeth of any of the racks desired. The disk 22 is mounted in any suitable manner as by means of a shaft 25 having bearing in the casing 2.

The pinion 24 is slidable on a rotatable shaft 26 and may be secured at any suitable location thereon through the adjustment of a set screw 27 extending through a screw threaded opening in a collar 28 of the pinion. Shaft 26 has rotatable bearing in a block 29 and a bracket 30. A bevel gear wheel 31 is keyed to the shaft 26 and meshes with the bevel gear wheel 32 keyed on a shaft 33. Shaft 33 extends through the casing 2 and has keyed thereon a pinion 34 which meshes with the pinion 35 mounted on a shaft 36 on which is also mounted a pulley 37. Driving means which may consist of a motor such as an electric motor 38, is mounted within the casing 2 and on the main shaft thereof is provided a pulley 39. A belt 40 passes over the pulleys 37 and 39.

Suitable means is employed to restore the carriage to position preparatory to moving across the machine and may be as follows. To the bearing member 11 is fastened as at 41, a flexible cord member 42 which passes over a guide pulley 43 supported from the casing by means of a bracket 44. The outer end of the cord member 42 has connected thereto a weight 45 which is slidable vertically on a rod 46 of a suitable bracket 47 supported from the casing 2.

Suitable escapement means is employed for rotating the platen or roller 13 a suitable extent after the end of a line on the copy has been reached, so that the succeeding line will be properly presented. Of such means as shown, 48 designates a shifting lever which is pivoted on a pin or short shaft 49 fastened to one of the brackets 15. A housing or box 50 is carried by the lever 48 be-

yond the pin and to this housing 50 and pin 49 is fastened opposite ends of a return spring 51. Projecting from the housing is a slidable pawl or tooth 52 which is normally pressed exteriorly of the housing, as shown best in Figs. 5 and 6, by means of a spring 53 located within the housing. On the end of the platen adjacent the shifting lever, is provided a band or the like having a plurality of serrations or teeth 54 thereon, as best seen in Figs. 3 and 5. The pawl 52 is adapted to engage the teeth 54 and by shifting thereof, partially rotate the platen 13.

It is desirable of shifting the lever 48 automatically during movement of the carriage and specifically while it is adjacent its innermost position. To this end lever 48 at its lower end is formed into a hook 49'. With this hook 49' is adapted to cooperate, a hook 50', suitably fastened to the housing 2 as at 55. This hook 50' is made of resilient or spring metal so that the lever 48 can move across the same in one direction without being shifted. After passing the spring hook 50' in said direction, the same springs upwardly so that it will engage the hook 49' on its return movement and cause the same to tilt before passing the same. In order to hold the spring hook rigid for this latter movement, a brace pin 56 is provided as shown in Fig. 3.

The shield 6, it will be noted, extends upwardly and over the platen 13, as best seen in Fig. 1, so that the same will shield the proper portion of the platen desired. The copy is shown in Fig. 1 as emerging or moving from behind the shield 6, and is designated 57. The usual hand gripping knobs for the platen are provided on the shafts or shaft 14 and designated 58.

In using the device, the typewriting machine preferably rests upon the portion 3 and accordingly, the copy carried by the platen 13 is so arranged that it is in or above the plane of the eyes. Motor 38 is started, which drives the belt 40 and accordingly pulley 37, shaft 36, pinions 35 and 34, and shaft 33. Shaft 33 through the medium of bevel gears 31 and 32, drives vertical shaft 26 and accordingly the pinion 24 and disk 22; the pinion 24 having previously been moved into mesh with the teeth of the rack desired. As the disk 22 revolves, one of the pins 21 engages the notch of pitman 19, which through its connection with the carriage, shifts or draws the carriage across the casing and accordingly draws or moves the copy 57 carried by the platen or the carriage. It will be seen that prior to the starting of the shifting movement of the carriage, that the same can be arranged so that the copy will be completely obscured by the shield 6 and that as the carriage moves laterally rela-

tively to the stationary shield, that the matter to be copied is gradually displayed, a letter at a time. As the carriage moves laterally, due to the connection of cord 42 thereto, the weight 45 is raised. When the carriage has been moved its limit, the pin 21 not engaged by the notch 20 of the pitman, strikes or abuts against the pitman and accordingly raises the same so as to disengage the other pin. Thereupon weight 45 descends on the guide rod 46 and moves with it the carriage, thereby restoring the same to starting position. When the carriage nearly reaches the end of its movement, shift lever 48 rides over and beyond the yieldable hook 50', depressing the same by such movement in order to permit the hook to pass it. As the weight 45 descends as just described, hook 49' engages the yieldable hook 50' which is now braced by the brace pin 56, causing lever 48 to be tilted and accordingly the pawl 52 to act against the adjacent or engaged tooth 54, thereby turning the platen the proper extent to bring the next line to be copied into proper position. The return spring 51 restores the parts to proper position after the shifting of the platen is effected.

In connection with the use of the copy-holder and display apparatus, it will be stated that the copy is at all times in or above the plane of the eyes of the operator of the typewriting machine, so that in order to follow the copy, the eyes cannot be lowered whereby a proper gage of the location of the keys and skill or ability to strike or operate the proper keys, is necessary to operate a typewriting machine. Such a device as the one of the present application is especially desirable in teaching the "touch system" of typewriting, with which system of course, the eyes at all times are trained upon the copy and do not have recourse to the keys, thus effecting considerable saving of time and enabling the operator of the typewriting machine to acquire greater speed in the operation of the keys.

The present invention is especially useful for testing purposes. When thus used, a copy is followed having a known number of words, the number being determined according to the length of time required for the test and the speed at which the machine operates. If the student or other operator of the typewriting machine cannot follow the pace set by the apparatus or moving copy, he must necessarily fall behind in his work and fail. The shield obscuring or shielding the copy as it does, prohibits the operator commencing the duplicate of the copy on the typewriting machine, until the motor is started, and also enables an even degree of speed to be maintained upon the typewriting machine inasmuch as the copy is displayed, a letter at a time. This is a

very desirable feature for speed tests, especially where there are a number of students, as it enables the copies for the various students to be displayed and started simultaneously. As the foregoing advantage and use explains the function of the device, other advantages and uses will suggest themselves to persons skilled in this art, and hence need not be set forth here.

The apparatus disclosed is of course, subject to mechanical refinements and to the employment of attachments and other desirable additions which have been omitted in the drawings for the sake of clearness, and as it is necessary to disclose only the salient features. Such refinements and changes in the construction of the apparatus described as fall within the spirit and scope of the appended claims, are reserved.

Having thus described our said invention, what we claim as new and desire to secure by Letters Patent is:

1. In a copy-holder, a carriage, a drive member, projections on said member arranged on opposite sides of the axis thereof, a pitman connected to said carriage alternately engaging one of said projections and tripped by the other of said projections, and return means for said carriage.

2. In a copy-holder a casing, a driving disk carried by said casing, a carriage member mounted upon said casing, an arm connected with said carriage, a pitman pivotally connected with said arm and releasably connected with said driving disk, means carried by said disk for disconnecting said pitman from said disk when said carriage reaches the extremity of its movement in one direction, means for returning said carriage to its original position when said pitman is released from said disk, and means for rotating said disk.

3. In a copy-holder a casing, a carriage slidably connected with said casing, a roller rotatably supported by said carriage, an escapement for turning said roller including an operating lever, means carried by said casing for engaging said lever to move said lever and rotate said roller when said carriage reaches the extremity of its movement in one direction, driving mechanism carried by said casing, means releasably connecting said carriage with said driving mechanism, and means for returning said carriage to its normal position when said first-mentioned means is released from said driving mechanism.

4. In a copy holder a movably mounted carriage, a rotary drive member, a pitman connected with said carriage, means for yieldably holding said carriage in a normal position, means carried by said rotary drive member for engaging said pitman to move said carriage out of its normal position, and means carried by said rotary drive member

for moving said pitman out of engagement with the engaging means carried by said rotary drive member.

5 5. In a copy holder a movably mounted carriage, means for yieldably holding said carriage in a normal position, a rotary drive member, means for automatically connecting said carriage with said drive member to permit said drive member to move said carriage out of its normal position, and 10 means for releasing said carriage from said drive member to permit said first mentioned means to return said carriage to its normal position.

5 6. In a copy holder a movably mounted carriage, means for yieldably holding said carriage in a normal position, a rotary driv-

ing element, an arm extending from said carriage for releasably engaging said driving element to move said carriage in one direction, and means carried by said driving element for releasing said arm when said carriage reaches the extremity of its movement and permitting said first mentioned means to return said carriage to its normal position. 20 25

In testimony whereof we affix our signatures in presence of two witnesses.

ANDREW E. VANCE.
OLIVER C. MORTRUDE.

Witnesses:

H. B. CARTER,
H. W. BRACKNEY.