

T. Hill,

Cut Off Valve.

No. 108137.

Patented Oct. 11. 1870.

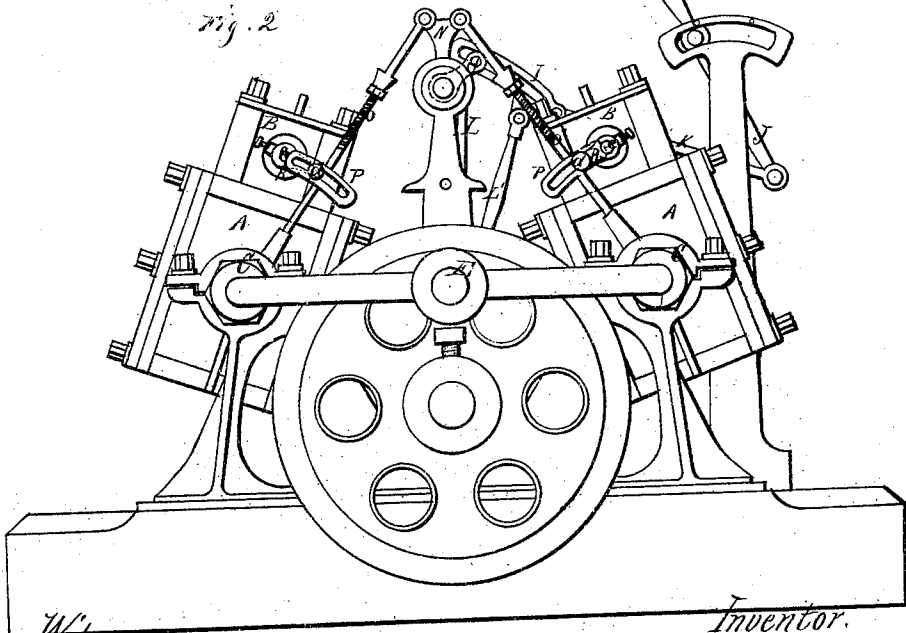
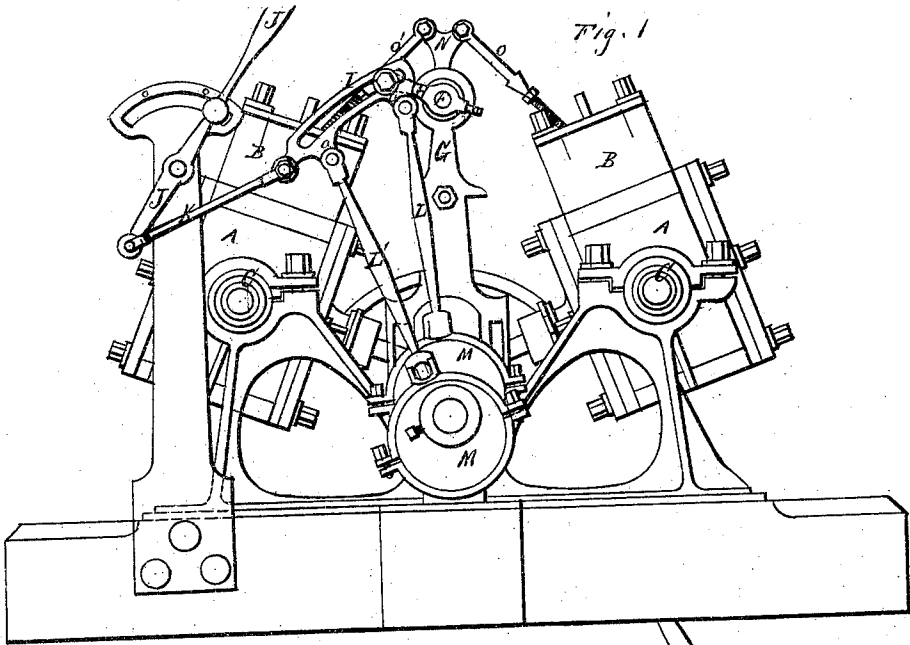

Witnesses
 Geo. H. Strong
 Wm. P. Boone

Inventor.
 Thomas Hill

T. Hill,

Cut Off Valve.

No. 108,137.

Patented Oct. 11. 1870.

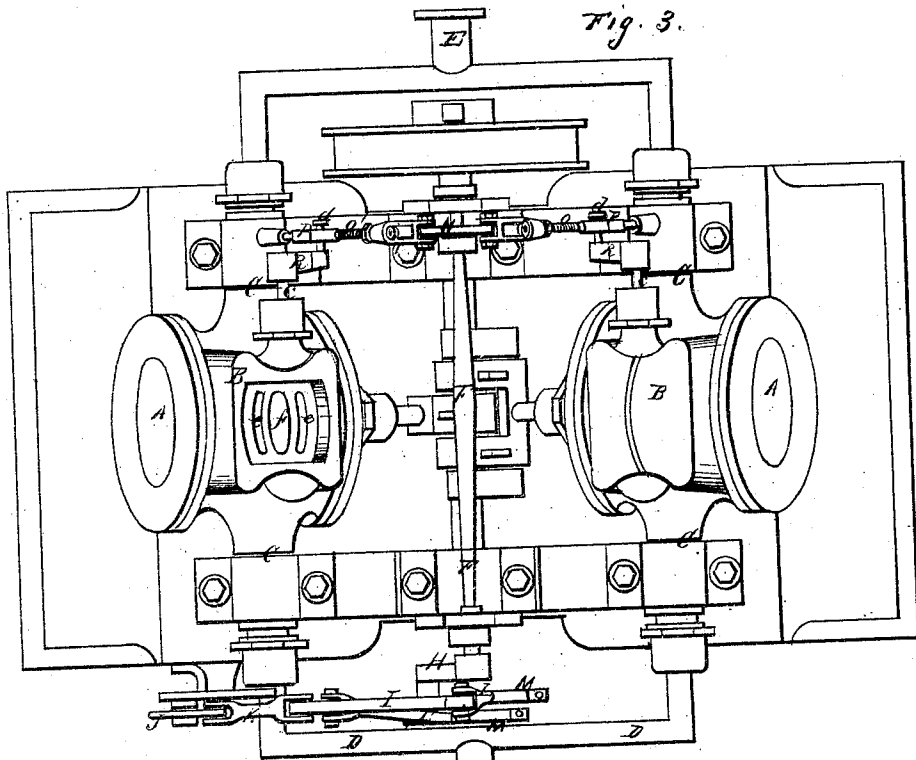

Fig. 3.

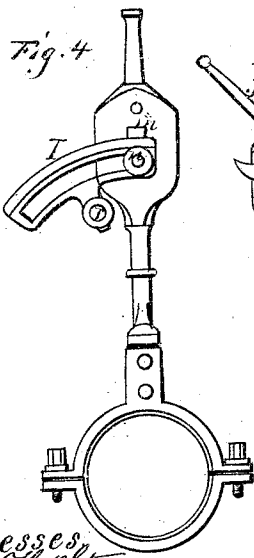

Fig. 4.

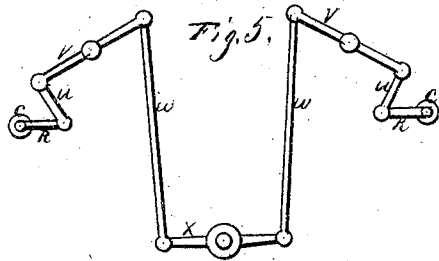
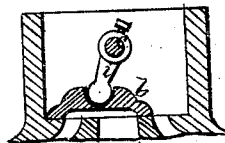
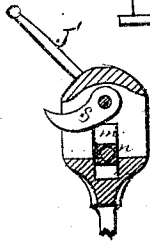

Fig. 5.

Witnesses:
 Geo. H. Strong,
 Wm. R. Boone

Inventor.
 Thomas Hill

United States Patent Office.

THOMAS HILL, OF VALLEJO, CALIFORNIA.

Letters Patent No. 108,137, dated October 11, 1870.

IMPROVEMENT IN VALVE-GEAR FOR STEAM-ENGINES.

The Schedule referred to in these Letters Patent and making part of the same.

To all whom it may concern:

Be it known that I, THOMAS HILL, of Vallejo, county of Solano, State of California, have invented an Improved Valve-Gear for Steam-Engines; and I do hereby declare the following description and accompanying drawing are sufficient to enable any person skilled in the art or science to which it most nearly appertains to make and use my said invention or improvements without further invention or experiment.

The object of my invention is to provide certain improvements in the valve-gear of steam-engines, by the use of which I am enabled to dispense with a portion of the mechanism hitherto found indispensable.

My invention has been more especially developed to apply to double oscillating marine-engines, and, by its use only one link and two eccentrics are necessary, in order to reverse both engines, and run them in either direction, and by a slight modification only one eccentric will be needed.

Besides marine-engines, my invention can be applied to other forms, and especially locomotives.

Referring to the accompanying-drawing for a more complete explanation of my invention—

A A are two cylinders of an oscillating engine, to which, in the present case, I have applied my invention.

B B are the steam-chests and valve-chambers.

The cylinders are mounted so as to oscillate upon trunnions at C, receiving steam through the branch-pipes D D and exhausting at E.

A rock-shaft, F, extends across, between, and above the cylinders, being supported upon the frame G.

At one end of this shaft is fastened a rocker-arm, H, a pin in its outer end entering the slot in the link I, and upon this the link travels when the engine is reversed.

This is effected by the reverse-lever J and connecting-rod K, which is pinned to the end of the link.

Two eccentric-rods L L' are pinned to the lugs a a, on the inside of the link, and through these the eccentrics M actuate the link.

At the opposite end of the shaft F from the link arises another rocker-arm, N, so formed as to have two points of attachment for the connecting-rods o o', by which the valves of the two engines are actuated.

At the lower end of each of these rods is secured a link, P, at right angles to the rod, and having a slot with a reverse curve.

A short crank or arm, R, is keyed to each valve-stem c, and its pin d enters the slot in the link, and by this it receives motion.

The valve b is a slide-valve, made proportionately rather large, and with rounded ends.

The steam-ports e e have a similar curve, and this gives the opportunity to make larger ports with a given steam-chest.

The exhaust-port f is made as shown, its sides forming a curve from each other, thus allowing the steam to escape freely.

In order to communicate motion from the valve-spindle, a short arm, i, is keyed to it, and projects downward into an opening in the top of the valve, so as to have a sort of rolling motion, resembling that of the ball-and-socket joint.

The operation of my engine is as follows:

The link being moved or set by the reverse lever, so as to bring the pin of the rocker-arm H under the influence of either of the eccentrics M, the shaft F will be turned a little way, so that the valves will, through their connections, receive a different set from that given by the other eccentric, and the motion of the engine will be reversed.

One eccentric might be employed, by constructing the upper end of the eccentric-rod as shown in Figure 4, a slot being made at m, so that as the pin n is thrown from one side to the other of the link it can travel up and down this slot.

This is rendered necessary from the fact that the link I is, in this case, keyed to the shaft F at the point r, and thus communicates motion to it.

The pin n is secured, after it arrives at either end of the link, by a cam, s, operated by the lever J'.

It is also possible to operate the valves by the oscillations of the engine alone.

For this purpose the valve-stem c has, in addition to the crank-arm R, a short arm, u, which connects it with the vibratory arm V.

This arm is connected, by a rod, w, to the arm X, which is pinned to the frame, as shown at Figure 5.

The arm X is stationary, except when reversing the engine, when its movements change the set of the valves.

By means of the arms R u v w the valves are operated by the simple oscillations of the engine.

Having thus described my invention,

What I claim, and desire to secure by Letters Patent, is—

1. The device for operating both valves from one rock-shaft, consisting of the double arm N, the rods O O', with their transverse links P and the arms R on the valve stem, substantially as herein described.

2. The link I, and either one or more eccentrics and rod or rods L, in conjunction with mechanism, as described, for operating the valve-gear of connected engines, substantially as set forth.

In witness that the above-described invention is claimed by me, I have hereunto set my hand and seal.

THOMAS HILL. [L. S.]

Witnesses:

GEO. H. STRONG,
WM. R. BOONE.