



- (51) International Patent Classification:
H04B 1/20 (2006.01)
- (21) International Application Number:
PCT/US2012/040559
- (22) International Filing Date:
1 June 2012 (01.06.2012)
- (25) Filing Language:
English
- (26) Publication Language:
English
- (30) Priority Data:
61/493,194 3 June 2011 (03.06.2011) US
13/485,764 31 May 2012 (31.05.2012) US
13/485,779 31 May 2012 (31.05.2012) US
13/485,800 31 May 2012 (31.05.2012) US
13/485,806 31 May 2012 (31.05.2012) US
13/485,819 31 May 2012 (31.05.2012) US

(US). **BROWN, Cordell** [US/US]; 1140 Carbon Junction #13, Durango, Colorado 81301 (US).

(74) **Agents: MADDEN, Robert B.** et al.; Schwegman, Lundberg & Woessner, P.A., P.O. Box 2938, Minneapolis, Minnesota 55402 (US).

(81) **Designated States** (unless otherwise indicated, for every kind of national protection available): AE, AG, AL, AM, AO, AT, AU, AZ, BA, BB, BG, BH, BR, BW, BY, BZ, CA, CH, CL, CN, CO, CR, CU, CZ, DE, DK, DM, DO, DZ, EC, EE, EG, ES, FI, GB, GD, GE, GH, GM, GT, HN, HR, HU, ID, IL, IN, IS, JP, KE, KG, KM, KN, KP, KR, KZ, LA, LC, LK, LR, LS, LT, LU, LY, MA, MD, ME, MG, MK, MN, MW, MX, MY, MZ, NA, NG, NI, NO, NZ, OM, PE, PG, PH, PL, PT, QA, RO, RS, RU, RW, SC, SD, SE, SG, SK, SL, SM, ST, SV, SY, TH, TJ, TM, TN, TR, TT, TZ, UA, UG, US, UZ, VC, VN, ZA, ZM, ZW.

(71) **Applicant** (for all designated States except US): **AIRBORNE MEDIA GROUP** [US/US]; 975 Main Avenue, Durango, Colorado 81301 (US).

(84) **Designated States** (unless otherwise indicated, for every kind of regional protection available): ARIPO (BW, GH, GM, KE, LR, LS, MW, MZ, NA, RW, SD, SL, SZ, TZ, UG, ZM, ZW), Eurasian (AM, AZ, BY, KG, KZ, RU, TJ, TM), European (AL, AT, BE, BG, CH, CY, CZ, DE, DK, EE, ES, FI, FR, GB, GR, HR, HU, IE, IS, IT, LT, LU, LV, MC, MK, MT, NL, NO, PL, PT, RO, RS, SE, SI, SK, SM, TR), OAPI (BF, BJ, CF, CG, CI, CM, GA, GN, GQ, GW, ML, MR, NE, SN, TD, TG).

(72) **Inventors; and**
(75) **Inventors/Applicants** (for US only): **GINN, Justin** [US/US]; 1030 East 3rd Avenue, Durango, Colorado 81301 (US). **DANFORD, Ryan** [US/US]; 715 East 4th Avenue, Durango, Colorado 81301 (US). **LILE, Chip** [US/US]; 16 Sage Hill Ct., Durango, Colorado 81301

[Continued on next page]

(54) **Title:** SYSTEMS AND METHODS FOR PROVIDING MULTIPLE AUDIO STREAMS IN A VENUE

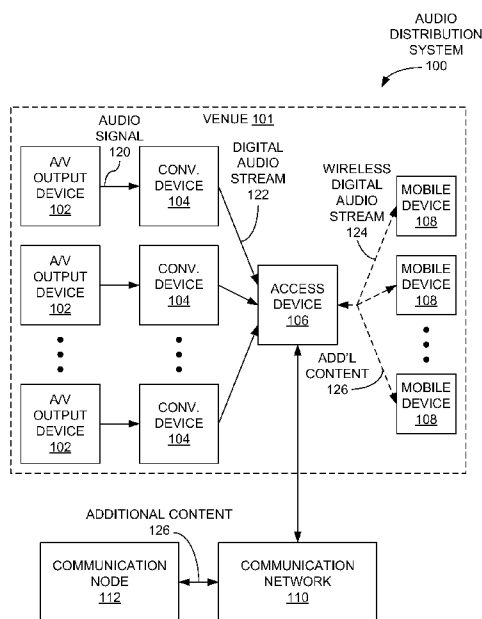

FIG. 1

(57) **Abstract:** Methods and systems for providing multiple audio streams, such as, for example, those audio streams that may be available in a public venue, are presented. An example system may include a plurality of audio relay devices and an access device. Each of the audio relay devices may receive an audio signal corresponding to video content being presented by a video presentation device, and transmit a digital audio stream representing the audio signal to the access device. The access device may receive each of the transmitted digital audio streams from the plurality of audio relay devices and transmit wirelessly the received digital audio streams to a mobile communication device.

WO 2012/167157 A1

Published:

— *with international search report (Art. 21(3))*

SYSTEMS AND METHODS FOR PROVIDING MULTIPLE AUDIO
STREAMS IN A VENUE

5

RELATED APPLICATIONS

[0001] This application claims the benefit of U.S. Patent Application No. 13/485,764, titled "SYSTEMS AND METHODS FOR PROVIDING MULTIPLE AUDIO STREAMS IN A VENUE," filed May 31, 2012; U.S. Patent Application No. 13/485,779, titled "VENUE-ORIENTED COMMERCE VIA MOBILE COMMUNICATION DEVICE," filed May 31, 2012; U.S. Patent Application No. 13/485,800, titled "VENUE-ORIENTED SOCIAL FUNCTIONALITY VIA A MOBILE COMMUNICATION DEVICE," filed May 31, 2012; U.S. Patent Application No. 13/485,806, titled "MOBILE DEVICE FOR VENUE-ORIENTED COMMUNICATIONS," filed May 31, 2012, and U.S. Patent Application No. 13/485,819, titled "COMMUNICATION NODE FOR VENUE-ORIENTED COMMUNICATIONS," filed May 31, 2012. Each of the above applications claims benefit to U.S. Provisional Application No. 61/493,194, titled "SYSTEMS AND METHODS FOR PROVIDING MULTIPLE AUDIO STREAMS IN A VENUE," filed June 3, 2011. Each of the aforementioned applications is hereby incorporated herein by reference in its entirety.

TECHNICAL FIELD

[0002] This application relates generally to venue-oriented communications and, more specifically, to systems and methods for providing one or more venue-oriented services, such as, for example, the distribution of multiple audio streams.

30 BACKGROUND

[0003] On both satellite and cable television distribution systems, numerous sports programs and events, as well as other audio/video content of interest, may be transmitted and presented simultaneously over different broadcast channels. Given the varying interest of potential patrons, some public

establishments, such as bars, sports books, and the like, may provide multiple televisions, video monitors, projection systems, and similar audio/video devices to provide many different such programs concurrently for the enjoyment of their clientele. Ordinarily, these devices are placed in relatively close proximity to
5 each other, or are placed in the same large room, so any patron of the establishment may view any of multiple video devices without changing locations within the establishment.

[0004] However, given such an arrangement of the audio/video devices within the establishment, allowing each of the audio/video devices, or some
10 related devices, to produce the audio for each program being displayed is impractical due to the confusing, and likely unintelligible, sounds that would result. To prevent such confusion, in some situations the audio associated with a single one of the programs being shown may be produced, such as the sound associated with the most popular program or event being presented in the
15 establishment at the time. Additionally, in some cases, one or more of the audio/video devices may be placed in a “closed captioning mode,” in which text reflecting the words spoken by sports announcers or others associated with the program is displayed on the screen to provide at least some reflection of the program audio to the patrons viewing that program.

20

BRIEF DESCRIPTION OF THE DRAWINGS

[0005] Some embodiments are illustrated by way of example and not limitation in the figures of the accompanying drawings in which:

[0006] FIG. 1 is a block diagram illustrating an example audio
25 distribution system including a plurality of converter devices and an access device;

[0007] FIG. 2 is a block diagram illustrating an example converter device implementable in the audio distribution system of FIG. 1;

[0008] FIG. 3 is a flow diagram illustrating an example method of
30 operating the example converter device of FIG. 2;

[0009] FIG. 4 is a block diagram illustrating an example access device implementable in the audio distribution system of FIG. 1;

[0010] FIG. 5 is a flow diagram illustrating an example method of operating the example access device of FIG. 4;

[0011] FIG. 6 is a block diagram illustrating an example mobile communication device implementable in the audio distribution system of FIG. 1;

[0012] FIG. 7 is a block diagram illustrating example modules implementable as control logic for the example mobile communication device of
5 FIG. 6;

[0013] FIG. 8 is a flow diagram illustrating an example method of operating the example mobile communication device of FIG. 6 to establish a communication connection between the mobile communication device and a wireless access device;

10 [0014] FIG. 9 is a flow diagram illustrating an example method of operating the example mobile communication device of FIG. 6 to provide a selected digital audio stream to a user;

[0015] FIG. 10 is a graphical representation of example information provided on a display of an example mobile communication device;

15 [0016] FIG. 11 is a block diagram illustrating at least one example audio distribution system facilitating an example chat communication between at least two mobile communication devices;

[0017] FIG. 12 is a flow diagram illustrating an example method of facilitating the connection of a mobile communication device with a chat room;

20 [0018] FIG. 13 is a flow diagram illustrating an example method of providing an example service to a mobile communication via an example access device;

[0019] FIG. 14 is a block diagram illustrating example modules of an example communication node portrayed in FIG. 1; and

25 [0020] FIG. 15 is a diagrammatic representation of a machine in the example form of a computer system within which a set of instructions for causing the machine to perform any one or more of the methodologies discussed herein may be executed.

30 DETAILED DESCRIPTION

[0021] Example methods and systems for distribution of multiple audio signals are discussed. In the following description, for purposes of explanation, numerous specific details are set forth in order to provide a thorough understanding of example embodiments. It will be evident, however, to one

skilled in the art that the present subject matter may be practiced without these specific details. It will also be evident that the venues and environments described herein in which audio signal distribution may occur are not limited to the examples provided and may include other scenarios not specifically
5 discussed.

[0022] In accordance with an example embodiment, FIG. 1 illustrates an audio distribution system 100. Generally, the audio distribution system 100 is configured to provide multiple streams of audio content to at least one mobile device 108. In an example, the audio distribution system 100 may be located at
10 a particular venue. In some implementations, the venue 101 may be a public venue, such as a restaurant, a drinking establishment, or a race and sports “book.” In such a venue, each of multiple audio/video output devices 102, such as televisions, video monitors, video projectors, and the like, may present one of a number of sporting events or other audio/video programs to customers or
15 viewers located at the venue. To allow the patrons of the venue to receive the audio portion being received by one of the output devices 102, the audio distribution system 100 makes available the audio from the output devices 102 to one or more mobile communication devices 108 held or possessed by patrons of the establishment. Examples of the mobile communication devices 108 include,
20 but are not limited to, cellular “smart” phones, personal digital assistants (PDAs), laptop computers, and tablet computers. In some implementations, each of the mobile communication devices 108 may be owned and operated by its respective user, or may be loaned or rented by operators of the venue 101 to the users.

[0023] In an example of the audio distribution system 100, each of the audio/video output devices 102 generating an audio signal that is desired to be distributed to users located at the venue 101 may be communicatively coupled with a converter device 104 (or, alternatively, an audio relay device 104), which may convert or otherwise transfer or relay the audio signal from its
25 corresponding output device 102 to a digital audio stream 122. Each converter device 104 may transmit its converted digital audio stream 122 to one or more access devices 106. The access device 106 distributes the received digital audio streams as one or more wireless digital audio streams 124 to the mobile communication devices 108. In one example, one or more of the converter
30

devices 104 may be integrated with each other, and/or with one or more of the access devices 106.

[0024] A user of each mobile communication device 108 may then select one of the digital audio streams 122 represented in the wireless digital audio stream 124 for reception and presentation at the mobile communication device 108 of the user. The user may then listen to the selected audio stream or channel, such as by way of a speaker incorporated into the mobile communication device 108, an earphone or headset connected to the mobile communication device 108, a Bluetooth®-enabled audio device communicatively coupled with the mobile communication device 108, or the like. As a result, each user possessing one of the mobile communication devices 108 may select and enjoy the audio portion of the audio/video content presented by way of one of the output devices 102.

[0025] In some examples, as is discussed in greater detail below, the audio distribution system 100 may also be employed as a communication conduit for offering one or more services associated with the venue 101, the audio/video content being presented via the output devices 102, or some other entity. These services may include, but are not limited to, chat rooms involving users of other mobile devices 108, advertising and sales associated with the venue 101 or other entities, customer loyalty programs associated with the venue 101 or another entity, social networking services involving other users of other mobile devices 108, and gaming or wagering services associated with the venue 101 or another entity. Such services may be organized and provided across the entire system 100, or according to some subdivision of the system 100, such as according to venue 101 or access device 106. In some examples, this functionality may be provided directly by the access device 106 or in conjunction with a communication node 112, such as an information server, communicatively coupled with the access device 106 by way of a communication network 110. Examples of the communication network 110 may include, but are not limited to, a wide-area network (WAN), such as an Intranet, the Internet, or some portion thereof, a local-area network (LAN), and an IEEE 802.11x (WiFi) network. Also, while the communication node 112 and the communication network 110 are shown as being located external to the venue

101, the communication node 112 and the network 110 may be located completely or partially within the venue 101 in other examples.

[0026] FIG. 2 is a block diagram of an example converter device 200 implementable as one of the converter devices 104 of FIG. 1. The converter device 200 may include an analog audio receiver 202, a conversion module 204, and a digital audio transmitter 206, although other components not explicitly depicted in FIG. 2 may also be included in the converter device 200 in other implementations.

[0027] The analog audio receiver 202 may be configured to receive an analog audio signal 102 from one of the audio/video output devices 102. In one example, the analog audio signal 102 is carried by way of a wire, cable, optical fiber, or other wired means from a standard analog “audio out” connector of the corresponding output device 102 to the converter device 200. In another implementation, the analog out connector may be attached to a wireless transmitter to carry the analog audio stream as an analog or digital wireless signal to the converter device 200. Other methods and apparatus for carrying the audio stream 120 to the converter device 200 may be employed in other embodiments. In yet further examples, the audio stream 120 generated by the audio/video output device 102 may be digital in nature, in which case the converter device 200 may or may not be required in order to present a corresponding digital audio stream 122 to the access device 106 of FIG. 1.

[0028] In some implementations, the converter device 202 may include multiple analog audio receivers 202 to receive audio content from multiple audio/video output devices 102 simultaneously. Such multiple analog audio signals may be converted and then combined into a single digital audio stream 122 or multiple digital audio streams 122 for transmission to the access device 106 of FIG. 1.

[0029] Presuming the audio stream 120 is an analog audio signal, the analog audio receiver 202 receives the audio signal 120 and provides the signal 120 to the conversion module 204. In one example, the analog audio receiver 202 includes an automatic gain control (AGC) function to adjust the gain of an amplifier of the analog audio receiver 202 to provide a somewhat consistent signal level for the input to the conversion module 204. In some instances, the

analog audio receiver 202 may incorporate other functionality, such as lag reduction and network optimization logic.

[0030] The conversion module 204 may then convert the received analog audio signal to a digital audio signal. In one example, the conversion module
5 204 includes at least one analog-to-digital conversion (ADC) circuit that samples the analog audio stream at a sufficiently high rate to generate a digital audio stream of acceptable quality for presentation on at least one of the mobile communication devices 108. In one implementation, the conversion module 204 may also include audio compression logic or circuitry that compresses the digital
10 audio data before transmission of the data to the access device 106. As a result, the resulting digital audio data may be in a compressed format (such as Motion Picture Experts Group-1, Audio Layer III (MP3) or Ogg) or an uncompressed format, depending on the particular embodiment.

[0031] The digital audio stream generated by the conversion module is
15 then forwarded to the digital audio transmitter 206 for transmission to the access device 106 of FIG. 1 as the digital audio stream 122. In one example, the digital audio stream 122 is transmitted over a wire, cable, optical fiber, or the like to the access device 106. In one example, the digital audio stream is transmitted via an Ethernet connection or network to the access device 106. More specifically, the
20 converter device 200 may be attached to an Ethernet network as a network appliance, along with other converter devices 200, for communicative coupling with the access device 106. Thus, the digital audio transmitter 206 may serve as an Ethernet transceiver that may possess a number of network configuration capabilities, including, but not limited to, dynamic and/or static Internet Protocol
25 (IP) addressing, Transmission Control Protocol/Internet Protocol (TCP/IP) functionality, User Datagram Protocol (UDP) functionality (possibly including a checksum calculated by the user of a UDP pseudo-header), and/or the like.

[0032] In another implementation, the digital audio stream 122 is transmitted wirelessly, such as by way of a WiFi or Bluetooth® protocol. If the
30 converter device 200 is instead incorporated within its respective access device 106, the digital audio transmitter 206 may be omitted from the converter device 200.

[0033] FIG. 3 is a flow diagram of an example method 300 of operating the converter device 200 of FIG. 2. In the method 300, the converter 200

receives an analog audio signal from an audio/video output device (operation 302). The converter device 200 converts the received analog audio signal to a digital audio stream (operation 304). As discussed above, the conversion process may also include generating a compressed digital audio stream. The resulting digital audio stream is then transmitted to an access device (operation 5 306).

[0034] FIG. 4 is a block diagram of an example access device 400 implementable as the access device 106 of FIG. 1. The example access device 400 may include one or more digital audio receivers 402, a wireless transceiver 10 406, a communication network interface 408, and control logic 404. In other examples, other components not explicitly shown in FIG. 4 may also be incorporated into the access device 400.

[0035] In the example of FIG. 4, each digital audio stream 122 generated by a converter device 104 may be received at a digital audio receiver 402 of the access device 400. In some implementations, such as the use of an Ethernet network to transmit and receive the digital audio streams 122, the digital audio receivers 402 may be embodied as a single Ethernet receiver or transceiver with multiple connectors, with each connector receiving a digital audio stream 122 from one of the converter devices 104. The Ethernet receiver may also act as a transceiver to provide the signals necessary to implement the Ethernet protocol, as controlled by the control logic 404. In other examples, a separate digital audio receiver 402 is used for each digital audio stream 122 to be received, as depicted in FIG. 4. 20

[0036] The control logic 404 may provide each of the received digital audio streams 122 to the wireless transceiver 406 for transmission as one or more wireless digital audio streams 124 to the mobile communication devices 108 of FIG. 1. In one example, the wireless transceiver 406, in conjunction with the control logic 404, operates as a transceiver operating under IEEE 802.11x (WiFi) protocols. In addition, the access device 400 may serve as a wireless router for transfer of additional content 126 between the various mobile communication devices 108. The access device 400 may, in some examples, operate as a router for transfer of information associated with the converter devices 200, including configuration information. 30

[0037] The communication network interface 408 is configured to facilitate communications between the access device 400 and the communication node 112 of FIG. 1 via the communication network 110. In one example, the communication network interface 408 employs an Ethernet connection for communication with a gateway device, such as a cable or digital subscriber line (DSL) modem in communication with the Internet or other communication network 110. In another example, the communication network interface 408 may incorporate the functionality of such a gateway device.

[0038] In some implementations, the control logic 404 may provide functionality, possibly under the guidance of a system administrator or other personnel, to support a number of functions related to the operation of the audio distribution system 100. These functions may include, but are not limited to, configuration and operation of the audio distribution functions, network management and administration of the mobile communication devices 108 as nodes of a LAN, and network routing functions for the LAN. The control logic 404 may also provide web-related functions, such as a captive portal and redirection functions similar to those associated with a “walled garden,” thus giving the proprietor of the venue 101 or other entity control over web content accessible by the mobile communication devices 108 via the access device 400. Further, in one example, the control logic 404 prevents mobile communication devices 108 that are not executing a specific application that may be required to communicate with the access device 400 from discovering a network access password needed to engage in communications with the access device 400.

[0039] The control logic 404, possibly in conjunction with the communication node 112 of FIG. 1, may also facilitate one or more of the services described above, such as chatting, gaming, point-of-sale transactions, customer loyalty programs, and the like. Examples regarding these various programs are discussed in greater detail below.

[0040] The control logic 404 may include electronic hardware, software, or some combination thereof, such as one or more processors configured to execute instructions that cause the processor to perform the various operations described herein that are attributed to the access device 400.

[0041] FIG. 5 illustrates an example method 500 of operating the access device 400 of FIG. 4. In the method 500, the access device 400 receives

multiple digital audio streams (operation 502), possibly from one or more converter devices, such as the converter device 200 of FIG. 2. The access device 400 transmits the multiple digital audio streams as one or more wireless digital audio streams to at least one mobile communication device (operation 504). The
5 access device 400 may also communicate additional content with the at least one mobile communication device and/or a communication node (operation 506), as noted above.

[0042] FIG. 6 is a block diagram illustrating an example mobile communication device 600 implementable as one or more of the mobile
10 communication devices 108 of FIG. 1. Examples of the mobile communication device 600 include, but are not limited to, “smart” phones, PDAs, laptop computers, and tablet computers. The mobile communication device 600 includes a wireless transceiver 602, a user interface 604, geographic location circuitry 606, and control logic 608. Other components not explicitly depicted in
15 FIG. 6 may be incorporated into the mobile communication device 600 in other embodiments.

[0043] The wireless transceiver 602 receives the one or more wireless digital audio streams 124 transmitted from an access device 106, as well as transmits and/or receives the additional content 126 mentioned above. In one
20 example, the wireless transceiver 602, under the operation of the control logic 608, communicates with the access device 106 using WiFi protocols. In some examples, the wireless transceiver 602 may also communicate with another communication network, such as a cellular telephone network employing CDMA (Code Division Multiple Access), GSM (Global System for Mobil
25 Communications), and/or other communication protocols.

[0044] In one embodiment, the wireless transceiver 602 may receive the one or more wireless digital audio streams 124 from a source other than the access device 106. For example, a centralized audio stream server (which may not be associated with, or located near, the venue 101 at which the mobile
30 communication device 600 is positioned) may provide at least some digital audio streams by way of the Internet or another communication network to the mobile communication device 600. Use of a centralized audio stream server may be appropriate in situations in which, for example, converter devices 104 are not

available at the venue 101, or business constraints, such as licensing restrictions, exist.

[0045] The user interface 604 allows a user of the mobile communication device 600 to interact with the mobile communication device 600. Such
5 interaction may include, for example, user selection of a wireless digital audio stream 124 received at the mobile communication device 600, user listening of the selected wireless digital audio stream 124, and user involvement with services provided via the access device 106 by way of the additional content 126 communicated between the mobile communication device 600 and the access
10 device 106. Components that may be incorporated as part of the user interface 604 may include, but are not limited to, a visual display (possibly integrated with a touch display or touchscreen), a keypad, an audio speaker and/or audio connector, a Bluetooth® interface for an audio speaker or earphone, a microphone, a camera, and an accelerometer.

[0046] The mobile communication device 600 may also include the geographic location circuitry 606, an example of which may be circuitry for receiving satellite signals from the Global Positioning System (GPS) that may be employed by the control logic 608 to determine the geographic location of the mobile communication device 600. As is described more fully below, the
20 control logic 608 may employ the location information to determine if a nearby access device 106 is available to the mobile device 600 for communication purposes.

[0047] The control logic 608 may control any and/or all of the other components of the mobile communications device 600, such as the wireless
25 transceiver 602, the user interface 604, and the geographic location circuitry 606. The control logic 404 may include electronic hardware, software, or some combination thereof, such as one or more processors configured to execute instructions that cause the processor to perform the various operations described herein that are attributed to the mobile communication device 600.

[0048] FIG. 7 is a block diagram of example modules incorporated as part of the control logic 608 of the mobile communications device 600 of FIG. 6. Each of the modules shown in FIG. 7 may include hardware, software, or some combination thereof. The example modules may include a communication
30 connection module 702, a channel selection module 704, a geographic location

module 706, a chat service module 708, an advertising/sales service module 710, a gaming service module 712, a customer loyalty service module 714, a user settings module 716, and a social network access module 718. Other modules not explicitly depicted in FIG. 7 may also be included in the control logic 5 608. In one example, one or more of the modules 702-714 may be included or represented in an application, or “app,” that may be loaded into, and executed by, the control logic 608 to provide the various functions described in greater detail provided by the mobile communication device 600.

[0049] In one example, the communication connection module 702 10 facilitates the creation of a communication connection between the mobile communication device 600 and the access device 106 to allow the reception of the one or more wireless digital audio streams 124, as well as the transmission and reception of the additional content 126. The communication connection module 702 may also assist in creating a secure connection between the mobile 15 communication device 600 and the access device 106 for various services described more fully below. In one example, the communication connection module 702 also facilitates creating a communication connection between the mobile communication device 600 and the communication node 112 of FIG. 1 and other nodes by way of an alternative communication network, such as a 20 cellular telephone network.

[0050] The channel selection module 704, in one example, presents identities of a set of audio channels to the user via the user interface 604 as carried in the one or more wireless digital audio streams 124, receives a user selection of one of the channels, and presents the selected channel to the user, 25 such as by way of an audio speaker or other audio output interface. In an example, the channel selection module 704 may present the identity of an audio channel associated with an identity of its corresponding audio/video output device 102 so that the user may discern which audio channel to select for the video content he is currently viewing.

[0051] In one example, the geographic location module 706, by utilizing the geographic location circuitry 606, may determine the current location of the mobile communication device 600 to decide which of multiple access devices 106 currently available are providing acceptable communication signals or signal strengths to the mobile communication device 600, and thus are the access

devices 106 most likely to provide audio content of interest to the user of the mobile communication device 600.

[0052] In another example, the current location of the mobile communication device 600 may be used to recommend other locations or venues that possess at least one access device 106 for the provision of the services described herein, especially in cases in which no access devices 106 are immediately available at the current location. This functionality is described in greater detail below.

[0053] In other situations, technologies other than the geographical location circuitry 606 may be utilized to determine with greater specificity a location of the mobile communication device 600. In just one example, the geographic location module 706 may be configured to decipher quick response (QR) codes placed at various locations in a venue 101 to determine the location of the mobile communication device 600 within the venue 101. Such information may then be made available to the communication node 112 to refine or otherwise direct the services provided to the mobile communication device 600, such as the delivery of food to a specific table equipped with the QR code. Other technologies, such as radio-frequency identification (RFID) technology, may be used to similar effect.

[0054] Generally, the chat service module 708, the advertising/sales service module 710, the gaming service module 712, and the customer loyalty service module 714 may facilitate communication in the form of the additional content 126 between the mobile communication device 600 and the access device 106 (and possibly the communication node 112) to provide the user of the mobile communication device 600 access to each of these services. Other examples of the mobile communication device 600, in conjunction with the access device 106, may provide to the user other services of interest that are not explicitly described herein.

[0055] The chat service module 708, discussed more fully below, may facilitate communications between the user of the mobile communication device 600 and the users of other connected mobile communication devices 600 via chat rooms. In some examples, such communications may be carried on between mobile communication devices 600 communicatively coupled to the

same access device 106, or to different access devices 106, whether located at the same venue or different venues.

[0056] The advertising/sales service module 710 may receive advertising from the access device 106 and present the received advertising to the user of the mobile communication device 600. In some examples, the advertising may be sourced by the venue 101, an advertiser associated with the audio channel selected by the user for reception, or another entity, such as a regional or national product or service provider. The advertising/sales service module 710 may also facilitate point-of-sale transactions and related processing and information transfer between the access device 106 and the mobile communication device 600. For example, the user may order food items, merchandise, or the like offered by the venue 101, and pay for the ordered items by way of a credit card or other account. Prior to such communications, the advertising/sales module 710 may invoke the communication connection module 702 to create a secure connection between the access device 106 and the mobile communication device 600 to protect the transmitted information associated with the transaction.

[0057] Similarly, the gaming service module 712 may facilitate the transfer of information relating to gaming and/or wagering between the mobile communication device 600 and the access device 106. For example, if the venue 101 is a gambling casino, the mobile communication device 600 may present offers regarding available wagers to be made on a particular outcome of an upcoming sporting event. In response, the user of the mobile communication device 600 may place a wager on a particular outcome of the event via the device 600 and transmit the wager via a secure connection with the access device 106. The results of the wager may then be presented to the user via the mobile communication device 600. In other examples, instead of a wager, the user may provide an answer to a trivia question posed by the venue 101, such as a sports bar.

[0058] To facilitate a customer loyalty program associated with the venue 101 or another entity, the customer loyalty service module 714 may receive information regarding available registration for a loyalty program (such as a program associated with the venue at which the user is located, for example), the current number of “points” or other indication regarding the

standing of the user within the loyalty program, information as to how the user may earn more points, information as to what the user may receive for redeeming a quantity of the earned points, and other related information, and present that information to the user. The user, in response, may register for the
5 loyalty program, earn more points, redeem previously earned points, or perform some other action regarding the customer loyalty program by providing response information via the mobile communication device 600 to the access device 106.

[0059] The user settings module 716 may allow a user to alter or change various settings or parameters that control the operation of the mobile
10 communication device 600 or the access device 106. Examples of such settings include, but are not limited to, details regarding how the mobile communication device 600 presents information to the user, information associated with the user (such as a chat “handle” or identifier for the user), selection of a LAN for communication with an access device 106, user visibility/anonymity settings,
15 and user preferences regarding reception of personalized offers or loyalty program subscriptions.

[0060] The social network access module 718 may allow a user to access social functions within the system 100, such as invitations, friend identification and location, business social marketing features, and interconnection with the
20 features of other social networks, such as Facebook®. In one example, a user may broadcast the location and current status of the user to friends or the entire system 100 upon the user initiating an application allowing access to the audio distribution system 100, or upon initiating a connection with an access device 106. In another implementation, the user may initiate the broadcast operation
25 via a selection “button” or other data entry mechanism provided by an application executing on the mobile communication device 600. In some examples, these and other social network functions are provided within the system 100 via API (Application Programming Interface) support from other social networks, such as Facebook®.

[0061] FIG. 8 is a flow diagram of an example method 800 for
30 establishing a communication connection between the mobile communication device 600 and an access device 106. In the method 800, the mobile communication device 600 determines any wireless access nodes or devices available to the mobile communication device 600 (operation 802), and transmits

a first list indicating the available wireless access devices to a communication node (operation 804), such as the communication node 112 of FIG. 1. This communication may occur, for example, over a cellular network connection with the Internet or another WAN coupled with the communication node. This first

5 list may be generated via a polling of information indicating signal strengths of nearby wireless access devices from the mobile communication device 600, such as by way of an API provided by the operating system of the device 600. The mobile communication device 600 may also transmit an indication of the geographic location of the device 600 to the communication node 112, as

10 supplied by the geographic location module 706. In response, the mobile communication device 600 may receive a second list indicating those wireless access devices of the first list that are available for providing the various services described herein (operation 806). If the second list is empty (in other words, no wireless access devices are listed) (operation 808), at least some functions

15 related to the services to be provided may be disabled (operation 810). Also, information may be presented to the user regarding the location of nearby out-of-range wireless access devices that may provide such services. Otherwise, if the second list is not empty, the mobile communication device 600 may receive an access password for each of the wireless access devices of the second list

20 (operation 812). The mobile communication device 600 may then present the second list to the user (operation 814). In response, the mobile communication device 600 may receive from the user a selection of the wireless access device to be used from the second list (operation 816). Based on the selection, the mobile communication device 600 may then establish a communication connection

25 between the mobile communication device 600 and the selected access device 106 using the access password for the selected wireless access device 106 (operation 818). In one example, the user is prevented from seeing the access passwords, thus keeping the identity of the passwords hidden. In another implementation, the mobile communication device 600 may automatically select

30 one of the available access devices 106 on behalf of the user. For example, the mobile communication device 600 may select, and establish a connection with, an access device 106 based on the detected signal strength of the access device 106.

[0062] FIG. 9 is a flow diagram of an example method 900 of receiving audio data into the mobile communication device 600 after a communication connection with the access device 106 has been established. In the method 900, the mobile communication device 600 receives a plurality of digital audio streams via the established communication connection (operation 902). Each of the streams may represent the audio content from a particular audio/video output device 102 in one implementation. In one example, the plurality of digital audio streams may be combined into fewer signal data streams, wherein the digital audio streams are multiplexed in some fashion. The mobile communication device 600 also receives information identifying the plurality of digital audio streams via the communication connection (operation 904). The information may include, in one implementation, an identification of the audio/video output device 102 that is sourcing the audio of each digital audio stream. After the mobile communication device 600 presents the identifying information to the user (operation 906), the mobile communication device 600 receives a selection of one of the digital audio streams from the user (operation 908). In response to the user selection, the mobile communication device 600 presents the selected digital audio stream to the user for listening (operation 910). In some implementations, the mobile communication device 600 may also transmit the user selection to the wireless access device 106 and/or the communication node 112 (operation 912), as the identification may allow presentation of additional content 126 (such as product or service advertising) that is related to the audio/video content being consumed by the user.

[0063] FIG. 10 is a graphical representation of an example mobile device display 1000 of the mobile communication device 600 presenting the identity of several digital audio data streams available for reception. More specifically, the display 1000 presents the identity of several different audio/video channels along with an identity of the particular audio/video output device 102 associated with the digital audio stream and a short description of the audio/video content. In one example, presuming the display 1000 is a touchscreen, the user need only touch one of the available audio channels, and the mobile communication device 600 begins presenting the audio for the selected channel in response. Also shown in the display 1000 may be an advertisement presented by the establishment or venue 101 in which the mobile communication device 600 is

located. Given the potential real-time nature of the information being presented to the user, the advertisement may incorporate a time-critical element, such as an expiration time.

[0064] In one example, upon the user selecting one of the available audio
5 channels, a second display associated with the selected audio channel may be presented to the user. This display may present information, such as the broadcast channel and the particular program or event involved, which is specifically associated with the selected audio channel. In some examples, the channel-specific display may include advertising, such as advertising
10 corresponding to the broadcast channel or the venue.

[0065] FIG. 11 is a block diagram of a system in which communications may be established between two or more mobile communication devices 600 via one or more chat rooms. In an example, an access device 106A located at a first venue 1101 may be employed to transmit chat content between a first mobile
15 communication device 600A and a second mobile communication device 600B located at the first venue 1101. In another example, one or both of the mobile devices 600A, 600B may engage in communications with a third mobile communication device 600C located at a second venue 1102 via the first access device 106A of the first venue 1101 and a second access device 106B located at
20 the second venue 1102. In this second example, the communication network 110 may take part in transferring the chat content 1110 between the various mobile communication devices 600. In one implementation, the communication node 112 provides assistance in one or more aspects of the chat rooms, such as the identification of the chat rooms that are currently available for users of the
25 system 100.

[0066] FIG. 12 is a flow diagram of an example method 1200 of establishing communications between two or more mobile communication devices 600 via a chat room. In the method 1200, the mobile communication device 600 transmits user identification regarding a user of the mobile
30 communication device 600 (operation 1202). In one example, this information may be transmitted to the access device 106 before or after a communication connection has been established with the access device 106. The mobile communication device 600 then receives an indication that at least one chat room is available for communication with other users (operation 1204). The

mobile communication device 600 may then present the indication to the user (operation 1206). The mobile communication device 600 may then receive a request from the user to join one of the chat rooms indicated (operation 1208). In response to the request, the mobile communication device 600 may then
5 establish a connection between the first user and the chat room to engage in communications with other users that have joined the same room (operation 1210). In some examples, a communication node 112 may initiate the process by transmitting to the mobile communication device 600 an invitation to join a chat room. More generally, the communication node 112 may also transmit an
10 invitation to a user to appear at a particular venue 101 or location.

[0067] FIG. 13 is a flow diagram illustrating an example method 1300 of a mobile communication device 600 providing to a user one of a number of services (for example, sales, gaming, social networking, and/or customer loyalty program services, as described above) supplied by the audio distribution system
15 100. In the method 1300, the mobile communication device 600 may receive information regarding a service from the communication node 112 via a previously established communication connection with an access device 106 (operation 1302). The mobile communication device 600 may then present the information to the user (operation 1304). Such information may include, for
20 example, possible wagers for the user to place, products or services for sale, and so on. A mobile communication device 600 may then receive a reply to the information from the user (operation 1306). Examples of such a reply may be, for example, a wager or a purchase request. In response to the reply, the mobile communication device 600 may then establish a secure connection, such as a
25 connection for transmitting encrypted data, using the established connection between the mobile communication device 600 and the communication node 112 via the access device 106 (operation 1308). The mobile communication device 600 may then facilitate communication between the mobile communication device 600 and the communication node 112 via the access device 106 over the
30 secure connection to provide the specific service to the user (operation 1310).

[0068] The communication node 112 of FIG. 1, in one example, may facilitate access by the mobile communication devices 108 to the various services described above, as well as to provide configuration and membership functionality related to the audio distribution systems discussed above. In some

implementations, the communication node 112 may be referred to as a server providing these various functions. Thus, the communication node 112 may include at least one computer processor executing instructions associated with a number of software modules to perform the various functions discussed below.

5 In some examples, a module may include software, electronic hardware, or some combination thereof.

[0069] FIG. 14 is a block diagram of example modules included in a communication node 1400, which may be representative of the communication node 112 of FIG. 1. The communication node 1400 includes an access device configuration module 1402, a venue subscription module 1404, a user administration module 1406, a user analytics module 1408, a user session profile module 1410, an advertising subscription module 1412, an advertising content module 1414, an advertising audience report module 1416, a social network service module 1418, a customer loyalty service module 1420, a gaming service module 1422, and one or more other service modules 1424. The communication node 1400 or server may include additional modules, or include fewer modules, than that shown in FIG. 14 in other implementations.

[0070] The access device configuration module 1402 may cause the communication node 1400 to communicate with an access device 106 by way of the communication network 110 to configure the access device 106, including, for example, network and communication parameters to be used by the access device 106, and information to be stored on the access device 106 for transfer to one or more mobile communication devices 108. In one example, the access device configuration module 1402 may also provide configuration information for one or more converter devices 104 in communication with the access device 106 via the access device 106. In some implementations, the access device configuration module 1402 may also control configurations of one or more of the mobile communication devices 108 by way of information transmitted via the access device 106.

30 [0071] The venue subscription module 1404 may perform operations associated with initiating and maintaining a subscription to one or more services available via the communication node 1400 by an entity associated with the venue 101 hosting the access device 106. In one example, such an entity may subscribe over some period of time, such as a year or a month, to provide any or

all of a number of services, including, but not limited to, an audio distribution service, a chat service, a gaming service, a customer loyalty service, and a point-of-sale service. Such a subscription, in one example, may allow the entity to provide one or more of the services to patrons or customers of the entity free of charge. The entity may also subscribe to an advertising service, as is described in greater detail below.

5 [0072] The user administration module 1406 may facilitate the registration of users of mobile communication devices 108 with the system 100. Such registration may, for example, allow the communication node 112 to store
10 identification data (such as a chat handle), credit card information, personal preferences, “friend” identifications of other users, and other data associated with the user. The maintenance of such information at the communication node 112 may allow the communication node 112 to recognize the user quickly and allow the user to employ the information regardless of the particular access
15 device 106 or venue 101 currently hosting the user. In some cases, the user administration module 1406 may also control access to the system 100 on a user-by-user basis, depending on previous activities of the user, the current number of users coupled to the system 100, and/or other factors.

[0073] The user analytics module 1408 may allow the communication
20 node 112 to track each connection or session to the system 100 by a user of a particular mobile communication device 108 via an access device 106, including, but not limited to, the types of services utilized by the user, and the particular audio content requested by the user. Such information may be beneficial for directing particular types of advertising to the user, offering
25 specific services to the user, and the like. In some examples, the communication node 112 may also employ the information to determine how the user employs the access device 106 and other portions of the system 100. In one example, by aggregating this information for each of the users, the communication node 112 may determine proper configurations for access devices 106 to make the system
30 100 more efficient, determine future equipment needs for the system 100, and so on. Thus, the metrics and related information provided via the user analytics module 1408 may be advantageous for both administrators of the system 100 and paid subscribers to the system 100.

[0074] The user session profile module 1410 may maintain a database of session profiles for each user (such as end users, entities associated with particular venues 101, system administrators, and the like) so that the communication node 112 may control user access to the system 100. Each of the session profiles may include, for example, a domain name, user name or log-in, password, and the like. A profile may also allow a user to access the system 100 by way of an access device 106, over the Internet, through a cellular phone network, or via some other communication path. In some examples, a session profile may also include information specific to the mobile communication device 108 employed by the user, such as the type and model of the device 108, the functional and performance capabilities of the device 108, and the like.

[0075] The advertising subscription module 1412 may facilitate the initiation and maintenance of advertising subscriptions by various entities, such as those associated with specific venues 101. In one example, an advertising subscription may allow an entity associated with a venue 101 to provide advertising to one or more mobile communication devices 108 coupled with an access device 106 located at the venue 101, as discussed above. Other entities, such as national or regional providers of goods or services that are not associated with a particular venue 101, may also subscribe to the advertising services provided by the system 100.

[0076] The advertising content module 1414 may provide means by which advertising subscribers may upload advertising content to the communication node 112 for subsequent transmission to mobile communication devices 108 by way of the system 100. In some examples, subscriber entities associated with a particular venue 101 may have their advertising delivered to mobile communication devices 108 communicatively coupled with an access device 106 located at the venue 101. Advertising supplied by national or regional subscribers may be transmitted to mobile communication devices 108 located at multiple venues 101.

[0077] In some implementations, the advertising supplied to a mobile communication device 108 may initiate other actions within the mobile communication device 108. For example, in response to a user touching or otherwise activating a displayed advertisement, the mobile communication device 108 may open a web browser and direct the browser to an associated web

page, such as a web page for the subscriber providing the advertisement. In another example, the mobile communication device 108 may initiate some activity, such as a game, a registration process in a loyalty program, a purchase, or a wager.

5 [0078] The advertising audience report module 1416 may generate and provide to advertising subscribers reports regarding users of the mobile communication devices 108 that receive, or are capable of receiving, the advertising provided by the advertising subscriber. Such information may include, for example, demographic information, personal interest information,
10 survey response information, point-of-sale transaction information, a number of advertisement impressions, a number of advertisements with user interaction, and the like, that the advertising subscriber may find useful in directing current and future advertising efforts.

[0079] The social network service module 1418, the customer loyalty
15 service module 1420, and the gaming service module 1422 facilitate the provision of the corresponding services discussed above with respect to the social network access module 718, the gaming service module 712, and the customer loyalty service module 714 of the mobile communication device 600, respectively. Each of these services is described in greater detail above. Each of
20 these modules 1418, 1420, 1422 may facilitate the services for each user at each venue associated with the system 100. Further, each service may be organized by venue, across the entire system 100, by corporate entity, by specific product brand, and/or by any other type of organizational structure applicable to social networks, gaming services, and customer loyalty programs.

25 [0080] One or more other service-specific modules 1424 may also be incorporated in the communication node 112 to facilitate one or more services, such as, for example, point-of-sale or mobile commerce (mCommerce) transactions. In one implementation, the communication node 112 provides the service-related information (offer of products, for example) to a user of a mobile
30 communication device 108 by way of the communication network 110 and the access device 106 that is communicatively coupled with the mobile communication device 108. The communication node 112 may also receive any responses to the service-related information (for example, product purchases) from the user via the same path, and process those responses in order to provide

the desired services. In other examples, point-of-sale transaction and other services may be provided to subscribers other than those entities associated with a particular venue 101.

5 [0081] While much of the above discussion focuses on certain public venues, such as restaurants, bars, and sports books, as likely locations for implementation of the systems and methods described herein, other venues, both public and private, such as airport terminals or gate areas, corporate reception lobbies, doctor's office waiting areas, and so on, may also benefit from application of the various concepts described herein.

10

MODULES, COMPONENTS, AND LOGIC

[0082] Certain embodiments, such as the converter devices 104, 200, the access devices 106, 400, the mobile communication devices 108, 600, and the communication nodes 112, 1400 discussed above, are described herein as including logic or a number of components, modules, or mechanisms. Modules may constitute either software modules (e.g., code embodied on a machine-readable medium or in a transmission signal) or hardware modules. A hardware module is a tangible unit capable of performing certain operations and may be configured or arranged in a certain manner. In example embodiments, one or more computer systems (e.g., a standalone, client, or server computer system) or one or more hardware modules of a computer system (e.g., a processor or a group of processors) may be configured by software (e.g., an application or application portion) as a hardware module that operates to perform certain operations as described herein.

25 [0083] In various embodiments, a hardware module may be implemented mechanically or electronically. For example, a hardware module may comprise dedicated circuitry or logic that is permanently configured (e.g., as a special-purpose processor, such as a field programmable gate array (FPGA) or an application-specific integrated circuit (ASIC)) to perform certain operations. A hardware module may also comprise programmable logic or circuitry (e.g., as encompassed within a general-purpose processor or other programmable processor) that is temporarily configured by software to perform certain operations. It will be appreciated that the decision to implement a hardware module mechanically, in dedicated and permanently configured circuitry, or in

temporarily configured circuitry (e.g., configured by software) may be driven by cost and time considerations.

[0084] Accordingly, the term "hardware module" should be understood to encompass a tangible entity, be that an entity that is physically constructed, 5 permanently configured (e.g., hardwired) or temporarily configured (e.g., programmed) to operate in a certain manner and/or to perform certain operations described herein. Considering embodiments in which hardware modules are temporarily configured (e.g., programmed), each of the hardware modules need not be configured or instantiated at any one instance in time. For example, 10 where the hardware modules comprise a general-purpose processor configured using software, the general-purpose processor may be configured as respective different hardware modules at different times. Software may accordingly configure a processor, for example, to constitute a particular hardware module at one instance of time and to constitute a different hardware module at a different 15 instance of time.

[0085] Hardware modules can provide information to, and receive information from, other hardware modules. Accordingly, the described hardware modules may be regarded as being communicatively coupled. Where 20 multiple such hardware modules exist contemporaneously, communications may be achieved through signal transmission (e.g., over appropriate circuits and buses) that connect the hardware modules. In embodiments in which multiple hardware modules are configured or instantiated at different times, communications between such hardware modules may be achieved, for example, through the storage and retrieval of information in memory structures to which 25 the multiple hardware modules have access. For example, one hardware module may perform an operation and store the output of that operation in a memory device to which it is communicatively coupled. A further hardware module may then, at a later time, access the memory device to retrieve and process the stored output. Hardware modules may also initiate communications with input or 30 output devices, and can operate on a resource (e.g., a collection of information).

[0086] The various operations of example methods described herein may be performed, at least partially, by one or more processors that are temporarily configured (e.g., by software) or permanently configured to perform the relevant operations. Whether temporarily or permanently configured, such processors

may constitute processor-implemented modules that operate to perform one or more operations or functions. The modules referred to herein may, in some example embodiments, comprise processor-implemented modules.

[0087] Similarly, the methods described herein may be at least partially
5 processor-implemented. For example, at least some of the operations of a method may be performed by one or more processors or processor-implemented modules. The performance of certain of the operations may be distributed among the one or more processors, not only residing within a single machine, but deployed across a number of machines. In some example embodiments, the
10 processor or processors may be located in a single location (e.g., within a home environment, an office environment, or as a server farm), while in other embodiments the processors may be distributed across a number of locations.

[0088] The one or more processors may also operate to support performance of the relevant operations in a "cloud computing" environment or as
15 a "software as a service" (SaaS). For example, at least some of the operations may be performed by a group of computers (as examples of machines including processors), these operations being accessible via a network (e.g., the Internet) and via one or more appropriate interfaces (e.g., APIs).

[0089] In one embodiment, a system may include an access device and a
20 plurality of audio relay devices, each audio relay device to receive from an audio/video presentation device an audio signal corresponding to video content being presented by the video presentation device and transmit a digital audio stream representing the audio signal to the access device. The access device is to receive each of the digital audio streams from the plurality of audio relay
25 devices, and transmit wirelessly the received digital audio streams to a mobile communication device.

[0090] In another embodiment, including all previous embodiments, the plurality of audio relay devices, the access device, and the mobile communication device are located within a single venue.

[0091] In another embodiment, including all previous embodiments, the
30 system further includes a communication node to transmit additional content to the access device, the access device to transmit the received additional content wirelessly to the mobile communication device.

[0092] In another embodiment, including all previous embodiments, the additional content is based on at least one of a venue or a geographic location in which the access device is located.

5 [0093] In another embodiment, including all previous embodiments, the additional content is based on one of the digital audio streams transmitted to the mobile communication device that is selected by a user of the mobile communication device for reception.

10 [0094] In another embodiment, including all previous embodiments, the additional content is based on profile information of a user of the mobile communication device.

[0095] In another embodiment, including all previous embodiments, the additional content includes information for at least one of point-of-sale transactions, mobile commerce transactions, a gaming service, a customer loyalty service, and a social networking service.

15 [0096] In another embodiment, including all previous embodiments, the system includes a communication node to receive additional content from the access device, the access device to receive the additional content wirelessly from the mobile communication device.

20 [0097] In another embodiment, including all previous embodiments, each of the plurality of audio relay devices operate as an appliance of a communication network, the plurality of audio relay devices to transmit the digital audio streams to the access device via the communication network.

25 [0098] In one embodiment, an access device includes at least one receiver to receive a plurality of digital audio streams, with each of the digital audio streams representing an audio signal corresponding to video content being presented by a video presentation device, and a wireless transceiver to transmit, to at least one mobile communication device for presentation to a user, a plurality of wireless digital audio streams, each of the wireless digital audio streams corresponding to one of the received digital audio streams.

30 [0099] In another embodiment, including all previous embodiments, the at least one receiver includes a plurality of digital audio receivers, each of the digital audio receivers to receive one of the digital audio streams.

[00100] In another embodiment, including all previous embodiments, the at least one receiver includes a receiver for a local area network, the receiver to receive each of the plurality of digital audio receivers via the local area network.

5 [00101] In another embodiment, including all previous embodiments, the access device further includes a communication network interface to facilitate communication with a communication node via a wide area network.

[00102] In another embodiment, including all previous embodiments, the communication network interface includes one of a cable modem and a digital subscriber line modem.

10 [00103] In another embodiment, including all previous embodiments, the wireless transceiver is to transmit and receive additional content between the communication network interface and the at least one mobile communication device.

[00104] In another embodiment, including all previous embodiments, the access device further includes control logic to transmit identifying information for the video presentation device associated with each of the plurality of wireless digital audio streams via the wireless transceiver to the at least one mobile communication device.

20 [00105] In one embodiment, an audio relay device includes an audio receiver to receive an audio signal from a video presentation device, the audio signal corresponding to video content being presented by the video presentation device; and a digital audio transmitter to transmit a digital audio stream based on the received audio signal to an access device for distribution to at least one mobile communication device for presentation to a user.

25 [00106] In another embodiment, including all previous embodiments, the received audio signal includes an analog audio signal, the audio relay device further including a conversion module to convert the analog audio signal to the digital audio stream transmitted by the digital audio transmitter.

[00107] In another embodiment, including all previous embodiments, the conversion module is to compress the digital audio stream prior to the digital audio transmitter transmitting the digital audio stream.

30 [00108] In another embodiment, including all previous embodiments, the audio receiver is physically coupled to an audio output of the video presentation device to receive the audio signal.

[00109] In another embodiment, including all previous embodiments, the digital audio transmitter is to transmit the digital audio stream over a wired connection to the access device.

5 [00110] In another embodiment, including all previous embodiments, the digital audio transmitter is to transmit the digital audio stream wirelessly to the access device.

[00111] In another embodiment, including all previous embodiments, the digital audio transmitter includes a transceiver for a local area network.

10 [00112] In one embodiment, a method includes establishing a wireless communication connection over a local area network between an access device and a mobile communication device; receiving at the access device a plurality of digital audio streams, each of the digital audio streams corresponding to video content being presented by a video presentation device to a user of the mobile communication device; and transmitting the received digital audio streams from
15 the access device to the mobile communication device using the wireless communication connection.

[00113] In another embodiment, including all previous embodiments, the method further includes receiving a password at the access device from the mobile communication device, the password being associated with the access
20 device, and the establishing of the wireless communication connection being in response to the receiving of the password.

[00114] In another embodiment, including all previous embodiments, the method further includes transmitting from the access device to the mobile communication device information identifying each of the plurality of digital
25 audio streams.

[00115] In another embodiment, including all previous embodiments, the method further includes transmitting from the access device to the mobile communication device information identifying the video presentation device associated with each of the plurality of digital audio streams.

30 [00116] In another embodiment, including all previous embodiments, the method further includes relaying information at the access device between a communication node and the mobile communication device to provide a customer service to the user of the mobile communication device.

[00117] In another embodiment, including all previous embodiments, the customer service includes a service corresponding to a venue in which the access device is located.

5 [00118] In another embodiment, including all previous embodiments, the customer service includes at least one of a sales service, a gaming service, a social networking service, and a customer loyalty program service.

[00119] In one embodiment, a system includes an access device located at a commercial venue, the access device being communicatively coupled via a local area network with a mobile communication device located at the commercial venue; and a communication node communicatively coupled to the access device via a wide area network, the communication node to provide a commercial service related to the commercial venue to a user of the mobile communication device; and the access device to exchange information between the communication node and the mobile communication device, the information relating to the commercial service.

15 [00120] In another embodiment, including all previous embodiments, the communication node includes a venue subscription module to maintain a subscription for a commercial entity associated with the commercial venue, the subscription allowing the commercial entity to provide the commercial service to the user of the mobile communication device.

[00121] In another embodiment, including all previous embodiments, the communication node includes a user administration module to register the user of the mobile communication device with the communication node, the registering of the user including storing information identifying the user.

25 [00122] In another embodiment, including all previous embodiments, the user administration module is to recognize the user of the mobile communication device while the mobile communication device is coupled to a second access device located at a second commercial venue communicatively coupled with the communication node based on the information identifying the user.

30 [00123] In another embodiment, including all previous embodiments, the communication node includes a user analytics module to monitor connections of the mobile communication device to the access device.

[00124] In another embodiment, including all previous embodiments, the user analytics module is to determine a type of commercial service provided to

the user of the mobile communication device based on the monitoring of the connections of the mobile communication device to the access device.

[00125] In another embodiment, including all previous embodiments, the user analytics module is to cause advertising to be directed to the mobile
5 communication device based on the type of commercial service provided to the user.

[00126] In another embodiment, including all previous embodiments, the user analytics module is to configure the access device based on the monitoring of the connections of the mobile communication device to the access device.

10 [00127] In another embodiment, including all previous embodiments, the communication node includes an advertising subscription module to maintain a subscription of an advertiser with the communication node, the advertising subscription allowing the advertiser to provide advertising to the mobile communication device via the communication node and the access node.

15 [00128] In another embodiment, including all previous embodiments, the advertiser is a commercial entity associated with the commercial venue.

[00129] In another embodiment, including all previous embodiments, the advertiser is a regional or national commercial entity not associated with the commercial venue.

20 [00130] In another embodiment, including all previous embodiments, the communication node includes an advertising content module to receive advertising content from an advertising subscriber of the communication node, to store the advertising content, and to transmit the advertising content to the mobile communication device via the access device.

25 [00131] In another embodiment, including all previous embodiments, the advertising subscriber includes a commercial entity associated with the commercial venue.

[00132] In another embodiment, including all previous embodiments, the advertising content includes an instruction to open a web page representing the
30 advertising subscriber in response to the user of the mobile communication device activating the advertising content on the mobile communication device.

[00133] In another embodiment, including all previous embodiments, the communication node includes an advertising audience report module to generate a report including information describing the user of the mobile communication

device, and to provide the report to an advertiser subscribed to the communication node.

5 [00134] In another embodiment, including all previous embodiments, the report includes information including at least one of demographic information, personal interest information, survey response information, and point-of-sale transaction information.

10 [00135] In another embodiment, including all previous embodiments, the communication node includes a point-of-sale module to offer a product available at the commercial venue to the user of the mobile communication device via the access device.

[00136] In another embodiment, including all previous embodiments, the communication node includes a mobile commerce module to offer a product to the user of the mobile communication device via the access device.

15 [00137] In another embodiment, including all previous embodiments, the communication node includes a customer loyalty service module to provide the user of the mobile communication device access to a customer loyalty program maintained by a commercial entity associated with the commercial venue.

20 [00138] In another embodiment, including all previous embodiments, the access node is to provide a point-of-sale transaction at the commercial venue for the user via the mobile communication device.

[00139] In another embodiment, including all previous embodiments, the access node is to provide access to the user via the mobile communication device of a customer loyalty program for the commercial entity associated with the commercial venue.

25 [00140] In another embodiment, including all previous embodiments, the access node is to receive a plurality of digital audio streams, each of the digital audio streams corresponding to video content being presented by a video presentation device at the commercial venue to the user, and to transmit wirelessly the received digital audio streams to the mobile communication device.

30 [00141] In one embodiment, an access device includes at least one receiver to receive a plurality of digital audio streams, each of the digital audio streams corresponding to video content being presented by a video presentation device; a wireless transceiver to transmit to a mobile communication device for

presentation to a user a plurality of wireless digital audio streams, each of the wireless digital audio streams corresponding to one of the received digital audio streams; and control logic to exchange information with the mobile communication device via the wireless transceiver to provide a commercial
5 service to the user of the mobile communication device.

[00142] In another embodiment, including all previous embodiments, the at least one receiver is to receive each of the digital audio streams from an audio relay device coupled to the video presentation device presenting the video content corresponding to the digital audio stream.

10 **[00143]** In another embodiment, including all previous embodiments, the access device further includes a communication network interface to receive at least one of the digital audio streams from a communication node communicatively coupled with the communication network interface.

[00144] In one embodiment, a method includes receiving a plurality of
15 digital audio streams, each of the digital audio streams corresponding to video content presented to a user via a video presentation device located at a commercial venue; transmitting wirelessly the plurality of digital audio streams to a mobile communication device of the user; and providing at least one commercial service related to the commercial venue to the user via the mobile
20 communication device.

[00145] In another embodiment, including all previous embodiments, the at least one commercial service includes a point-of-sale service for facilitating a purchase by the user, the point-of-sale service being related to the commercial venue.

25 **[00146]** In another embodiment, including all previous embodiments, the at least one commercial service includes a customer loyalty service related to the commercial venue.

[00147] In one embodiment, a system includes an access device located at a commercial venue, the access device being communicatively coupled via a
30 local area network with a mobile communication device located at the commercial venue; and a communication node communicatively coupled to the access device via a wide area network, the communication node to provide a social networking service related to the commercial venue to a user of the mobile communication device; the access device to exchange information between the

communication node and the mobile communication device, the information relating to the social networking service.

[00148] In another embodiment, including all previous embodiments, the social networking service includes a chat service, the access node to receive
5 from the mobile communication device an identification of the user, the access node to transmit an indication of chat rooms available for the user to join, the access node to receive a request from the mobile communication device for the user to join an indicated one of the chat rooms, the access node to facilitate establishment of a communication connection between the mobile
10 communication device and the chat room in response to the request.

[00149] In another embodiment, including all previous embodiments, the communication node is to transmit the indication of the chat rooms available for the user to join to the access device.

[00150] In another embodiment, including all previous embodiments, the
15 communication node is to transmit an invitation for the user to join one of the chat rooms via the access node to the mobile communication device.

[00151] In another embodiment, including all previous embodiments, the social networking service includes a chat service, the access device to transmit chat content of a chat room between the mobile communication device and a
20 second mobile communication device located at the commercial venue.

[00152] In another embodiment, including all previous embodiments, the social networking service includes a chat service, the access device to transmit chat content of a chat room between the mobile communication device and a second access device located at a second commercial venue via the wide area
25 network.

[00153] In another embodiment, including all previous embodiments, the social networking service includes a social network to facilitate at least one of a friend invitation, a friend identification, and a friend location between the mobile communication device and a second mobile communication device located at the
30 commercial venue.

[00154] In another embodiment, including all previous embodiments, the social networking service includes interconnection between the mobile communication device and an external social network, the communication node

providing the interconnection via an application programming interface provided by the external social network.

5 [00155] In another embodiment, including all previous embodiments, the social networking service includes access to a social network, the communication node to receive at least one of a location and a current status of the user from the mobile communication device via the access device, the communication node to forward the at least one of the location and the current status of the user to other mobile communication devices located at the commercial venue via the access device.

10 [00156] In another embodiment, including all previous embodiments, the communication node is to receive the at least one of the location and the current status of the user in response to a communication connection being established between the mobile communication device and the access node.

15 [00157] In another embodiment, including all previous embodiments, the social networking service includes a gaming service, the commercial venue including a gambling establishment, the access device to receive a wager to be placed with the gambling establishment from the mobile communication device over a secure communication connection, the access device to transmit a result of the wager to the mobile communication over the secure communication
20 connection.

[00158] In another embodiment, including all previous embodiments, the social networking service includes a gaming service, the access device to receive an answer to a question posed to the user at the commercial venue.

25 [00159] In another embodiment, including all previous embodiments, the access node is to receive a plurality of digital audio streams, each of the digital audio streams corresponding to video content being presented by a video presentation device at the commercial venue to the user, and to transmit wirelessly the received digital audio streams to the mobile communication device.

30 [00160] In another embodiment, including all previous embodiments, the system further includes at least one audio relay device to transmit each of the digital audio streams to the access node, each of the digital audio streams being based on an audio signal received at the at least one audio relay device from the video presentation device.

[00161] In one embodiment, an access device includes at least one receiver to receive a plurality of digital audio streams, each of the digital audio streams corresponding to video content being presented by a video presentation device; a wireless transceiver to transmit to a mobile communication device for presentation to a user a plurality of wireless digital audio streams, each of the wireless digital audio streams corresponding to one of the received digital audio streams; and control logic to exchange information with the mobile communication device via the wireless transceiver to provide a social networking service to the user of the mobile communication device.

5
10 [00162] In another embodiment, including all previous embodiments, the at least one receiver is to receive each of the digital audio streams from an audio relay device coupled to the video presentation device presenting the video content corresponding to the digital audio stream.

[00163] In another embodiment, including all previous embodiments, the access device further includes a communication network interface to receive at least one of the digital audio streams from a communication node communicatively coupled with the communication network interface.

15
20 [00164] In one embodiment, a method includes receiving a plurality of digital audio streams, each of the digital audio streams corresponding to video content presented to a user via a video presentation device located at a commercial venue; transmitting wirelessly the plurality of digital audio streams to a mobile communication device of the user; and providing at least one social networking service related to the commercial venue to the user via the mobile communication device.

25 [00165] In another embodiment, including all previous embodiments, the at least one social networking service includes a chat service for use between the mobile communication device and a second mobile communication device.

[00166] In another embodiment, including all previous embodiments, the second mobile communication device is located at the commercial venue and communicatively coupled with the access device.

30 [00167] In another embodiment, including all previous embodiments, the second mobile communication device is located at a separate commercial venue and communicatively coupled with the access device via a wide area network and a second access device located at the separate commercial venue.

- [00168] In another embodiment, including all previous embodiments, the at least one social networking service includes a social network.
- [00169] In another embodiment, including all previous embodiments, the at least one social networking service includes a gaming service.
- 5 [00170] In one embodiment, a mobile communication device includes a wireless transceiver to receive a plurality of digital audio streams from an access device located at a venue; a user interface to receive a selection of one of the digital audio streams from a user of the mobile communication device; and control logic comprising a channel selection module to generate an audio signal
- 10 representing the selected one of the digital audio streams; the user interface to provide the generated audio signal for presentation to the user.
- [00171] In another embodiment, including all previous embodiments, the user interface is to present an identity of each of the plurality of digital audio streams to the user prior to receiving the selection of the one of the digital audio
- 15 streams.
- [00172] In another embodiment, including all previous embodiments, each of the plurality of digital audio streams corresponds to video content presented to the user via at least one of a plurality of video presentation devices located at the venue.
- 20 [00173] In another embodiment, including all previous embodiments, the user interface is to present to the user an identity of at least one of the plurality of video presentation devices for each corresponding one of the plurality of digital audio streams prior to receiving the selection of the one of the digital audio streams.
- 25 [00174] In another embodiment, including all previous embodiments, the control logic includes a communication connection module to facilitate creation of a communication connection between the mobile communication device and the access device prior to receiving the plurality of digital audio streams from the access device.
- 30 [00175] In another embodiment, including all previous embodiments, the communication connection module is to facilitate creation of a second communication connection between the mobile communication device and a communication node communicatively coupled with the access device via a wide area network.

[00176] In another embodiment, including all previous embodiments, the control logic includes a geographic location module to determine a current location of the mobile communication device, the geographic location module to select the access device from a plurality of access devices, the control logic
5 further including a communication connection module to facilitate creation of a communication connection between the mobile communication device and the access device prior to receiving the plurality of digital audio streams from the access device.

[00177] In another embodiment, including all previous embodiments, the
10 mobile communication device further includes geographic location circuitry to generate an indication of the current location of the mobile communication device for the geographic location module.

[00178] In another embodiment, including all previous embodiments, the geographic location circuitry includes global positioning system circuitry.

15 [00179] In another embodiment, including all previous embodiments, the control logic includes a geographic location module to determine a current location of the mobile communication device within the venue, the control logic to provide a service delivered by the access device to the user based on the location.

20 [00180] In another embodiment, including all previous embodiments, the user interface is to capture an image of a graphical code located in the venue, the geographic location module to decipher the graphical code from the captured image, the geographic location module to determine the current location based on the deciphered graphical code.

25 [00181] In another embodiment, including all previous embodiments, the wireless transceiver is to read location information from a radio-frequency identifier circuit located in the venue, the geographic location module to determine the current location based on the location information.

[00182] In one embodiment, a method includes establishing a
30 communication connection with a wireless access device at a venue shared with the mobile communication device; receiving a plurality of digital audio streams from the wireless access device after establishing the communication connection; receiving information identifying the plurality of digital audio streams; presenting, using at least one processor of a machine, the information

identifying the plurality of digital audio streams to a user of the mobile communication device; receiving a selection of one of the plurality of digital audio streams from the user; and presenting the selected digital audio stream to the user.

5 [00183] In another embodiment, including all previous embodiments, each of the plurality of digital streams corresponds to video content being presented to the user by a video presentation device located at the venue.

[00184] In another embodiment, including all previous embodiments, the method further includes presenting information identifying the video
10 presentation device corresponding to each of the plurality of digital audio streams to the user of the mobile communication device.

[00185] In one embodiment, a non-transitory computer-readable storage medium includes instructions that, when executed on at least one processor of a mobile communication device, cause the mobile communication device to
15 establish a communication connection with a wireless access device; receive a plurality of digital audio streams from the wireless access device over the communication connection, each of the plurality of digital audio streams being generated at a venue shared with the mobile communication device; receive information identifying each of the plurality of digital audio streams; present the
20 information identifying the plurality of digital audio streams to a user of the mobile communication device; receive a selection of one of the plurality of digital audio streams from the user; and present the selected digital audio stream to the user.

[00186] In another embodiment, including all previous embodiments, the
25 instructions further cause the mobile communication device to transmit the selection of the one of the plurality of digital audio streams to the wireless access device.

[00187] In another embodiment, including all previous embodiments, the instructions further cause the mobile communication device to receive
30 advertising information from the wireless access device; and present the advertising information to the user.

[00188] In another embodiment, including all previous embodiments, the advertising information is associated with the venue.

[00189] In another embodiment, including all previous embodiments, the instructions further cause the mobile communication device to transmit the selection of the one of the plurality of digital audio streams to the wireless access device, the advertising information being based on the selected one of the
5 plurality of digital audio streams.

[00190] In another embodiment, including all previous embodiments, the advertising information is based on a demographic group associated with the user.

[00191] In another embodiment, including all previous embodiments, the
10 instructions further cause the mobile communication device to transmit user identification information associated with the user to at least one of the wireless access device and a communication node; in response to transmitting the user identification information, receive an indication from at least one of the wireless access device and the communication node that at least one chat room is
15 available for communication; present the indication to the user; receive from the user a request to establish a communication link with one of the at least one chat room; and establish the communication link between the user and the one of the at least one chat room via the wireless access device in response to the request.

[00192] In another embodiment, including all previous embodiments, the
20 instructions further cause the mobile communication device to determine a plurality of wireless access nodes available to the mobile communication device; transmit a list indicating the plurality of wireless access nodes to a communication node; transmit an indication of a geographic location of the mobile communication device to the communication node; and receive from the
25 communication node information identifying at least one wireless access node from the list, the at least one wireless access node being available to provide a service to the mobile communication device at the indicated geographic location, the at least one available wireless access node comprising the wireless access device; the establishing of the communication connection occurring in response
30 to receiving the identifying information.

[00193] In another embodiment, including all previous embodiments, the instructions further cause the mobile communication device to receive the indication of the geographic location of the mobile communication device from geographic location circuitry of the mobile communication device, the

geographic location circuitry being in communication with a global positioning system external to the mobile communication device.

5 [00194] In another embodiment, including all previous embodiments, the instructions further cause the mobile communication device to receive from the communication node an indication that none of the wireless access nodes from the list are available to provide the service, and an indication of at least one out-of-range wireless access node near the geographic location of the mobile communication device that is capable of providing the service.

10 [00195] In another embodiment, including all previous embodiments, the instructions further cause the mobile communication device to determine a location of the mobile communication device within the venue; transmit an indication of the location to a communication node; and communicate with the communication node with respect to a service provided via the wireless access device, the service being based on the indication of the location.

15 [00196] In another embodiment, including all previous embodiments, the instructions further cause the mobile communication device to receive information for a venue-oriented service from the wireless access device; present the information for the venue-oriented service to the user; establish a secure connection with the wireless access device; and transmit response information
20 for the venue-oriented service to the wireless access device via the secure connection.

[00197] In another embodiment, including all previous embodiments, the venue-oriented service includes at least one of a point-of-sales service, a mobile commerce service, and a customer loyalty service.

25 [00198] In another embodiment, including all previous embodiments, the venue-oriented service includes a gaming service.

[00199] In another embodiment, including all previous embodiments, the venue-oriented service includes a social networking service.

30 [00200] In one embodiment, a communication node includes a network interface to communicatively couple the communication node with a wireless access device, the wireless access device being in communication with a mobile communication device, the wireless access device and the mobile communication device located at a venue; at least one processor; and a memory storing modules including instructions for execution by the at least one

processor, at least one of the modules providing a venue-oriented service to the mobile communication device via the wireless access device.

5 [00201] In another embodiment, including all previous embodiments, the at least one of the modules include an audio distribution service module to distribute, via the wireless access device, a plurality of audio streams to a user of the mobile communication device, each of the plurality of audio streams corresponding to video content being presented to the user at the venue.

10 [00202] In another embodiment, including all previous embodiments, the at least one of the modules include a commerce module to offer, via the wireless access device, a product for purchase by a commercial entity related to the venue to a user of the mobile communication device.

[00203] In another embodiment, including all previous embodiments, the purchases include at least one of point-of-sale transactions and mobile commerce transactions.

15 [00204] In another embodiment, including all previous embodiments, the at least one of the modules include a customer loyalty service module to provide a user of the mobile communication device, via the wireless access device, access to a customer loyalty program maintained by a commercial entity associated with the venue.

20 [00205] In another embodiment, including all previous embodiments, the at least one of the modules include a social network service module to provide a user of the mobile communication device, via the wireless access device, access to an external social network via an application programming interface provided by the external social network.

25 [00206] In another embodiment, including all previous embodiments, the at least one of the modules include a social network service module to provide a user of the mobile communication device, via the wireless access device, access to a social network associated with the venue.

30 [00207] In another embodiment, including all previous embodiments, the communication node is to receive at least one of a location and a current status of the user from the mobile communication device via the wireless access device, the communication node to forward the at least one of the location and the current status of the user to other mobile communication devices located at the venue via the wireless access device.

[00208] In another embodiment, including all previous embodiments, the at least one of the modules include a social network service module to provide a user of the mobile communication device, via the wireless access device, access to chat rooms associated with the venue.

5 [00209] In another embodiment, including all previous embodiments, the at least one of the modules include a gaming service module to provide a user of the mobile communication device, via the wireless access device, access to a gaming service corresponding to a gaming establishment located at the venue.

[00210] In another embodiment, including all previous embodiments, the
10 at least one of the modules include a gaming service module to provide a user of the mobile communication device, via the wireless access device, access to a gaming service corresponding to a commercial entity located at the venue.

[00211] In another embodiment, including all previous embodiments, the
15 modules include a venue subscription module to maintain a subscription for a commercial entity associated with the venue, the subscription allowing the commercial entity to provide the venue-oriented service to the user of the mobile communication device.

[00212] In another embodiment, including all previous embodiments, the
20 modules further include a user administration module to register the user of the mobile communication device with the communication node, the registering of the user comprising storing information identifying the user.

[00213] In another embodiment, including all previous embodiments, the
25 user administration module is to recognize the user of the mobile communication device while the mobile communication device is coupled to a second wireless access device located at a second venue communicatively coupled with the communication node based on the information identifying the user.

[00214] In another embodiment, including all previous embodiments, the modules include a user analytics module to monitor connections of the mobile communication device to the wireless access device.

30 [00215] In another embodiment, including all previous embodiments, the user analytics module is to determine a type of the venue-oriented service provided to the user of the mobile communication device based on the monitoring of the connections of the mobile communication device to the wireless access device.

- [00216] In another embodiment, including all previous embodiments, the user analytics module is to cause advertising to be directed to the mobile communication device via the wireless access device based on the type of the venue-oriented service provided to the user.
- 5 [00217] In another embodiment, including all previous embodiments, the user analytics module is to configure the wireless access device based on the monitoring of the connections of the mobile communication device to the wireless access device.
- [00218] In another embodiment, including all previous embodiments, the modules include an advertising subscription module to maintain a subscription of an advertiser with the communication node, the advertising subscription allowing the advertiser to provide advertising to the mobile communication device via the communication node and the wireless access node.
- 10 [00219] In another embodiment, including all previous embodiments, the advertiser is a commercial entity associated with the venue.
- [00220] In another embodiment, including all previous embodiments, the advertiser is a regional or national commercial entity not associated with the venue.
- [00221] In another embodiment, including all previous embodiments, the modules include an advertising content module to receive advertising content from an advertising subscriber of the communication node, to store the advertising content, and to transmit the advertising content to the mobile communication device via wireless the access device.
- 20 [00222] In another embodiment, including all previous embodiments, the advertising subscriber includes a commercial entity associated with the venue.
- [00223] In another embodiment, including all previous embodiments, the advertising content includes an instruction to open a web page representing the advertising subscriber in response to the user of the mobile communication device activating the advertising content on the mobile communication device.
- 30 [00224] In another embodiment, including all previous embodiments, the modules include an advertising audience report module to generate a report including information describing the user of the mobile communication device, and to provide the report to an advertiser subscribed to the communication node.\

[00225] In another embodiment, including all previous embodiments, the report includes information including at least one of demographic information, personal interest information, survey response information, and point-of-sale transaction information.

5 [00226] In another embodiment, including all previous embodiments, the modules include a user session profile module to control access of the user to the wireless access device and the communication node.

[00227] In one embodiment, a method includes establishing a communication connection with a wireless access device located at a venue, the wireless access device in communication with a mobile communication device located at the venue; transmitting information describing a service related to the venue to the mobile communication device via the wireless access device; receiving a reply to the information from the wireless access device; establishing a secure connection with the mobile communication device using the communication connection in response to receiving the reply; and providing, using at least one processor of a machine, the service to the mobile communication device using the secure connection.

10

15

[00228] In another embodiment, including all previous embodiments, the service includes at least one of an audio-distribution service, a commercial service, and a social networking service.

20

[00229] In one embodiment, a non-transitory computer-readable storage medium includes instructions that, when executed by at least one process of a machine, cause the machine to perform operations including establishing a communication connection with a wireless access device located at a venue, the wireless access device in communication with a mobile communication device located at the venue; transmitting information describing a service related to the venue to the mobile communication device via the wireless access device; receiving a reply to the information from the wireless access device; establishing a secure connection with the mobile communication device using the communication connection in response to receiving the reply; and providing the service to the mobile communication device using the secure connection.

25

30

ELECTRONIC APPARATUS AND SYSTEM

[00230] Example embodiments may be implemented in digital electronic circuitry, or in computer hardware, firmware, or software, or in combinations thereof. Example embodiments may be implemented using a computer program
5 product (e.g., a computer program tangibly embodied in an information carrier in a machine-readable medium) for execution by, or to control the operation of, data processing apparatus (e.g., a programmable processor, a computer, or multiple computers).

[00231] A computer program can be written in any form of programming
10 language, including compiled or interpreted languages, and it can be deployed in any form, including as a stand-alone program or as a module, subroutine, or other unit suitable for use in a computing environment. A computer program can be deployed to be executed on one computer or on multiple computers at one site or distributed across multiple sites and interconnected by a communications
15 network.

[00232] In example embodiments, operations may be performed by one or more programmable processors executing a computer program to perform functions by operating on input data and generating output. Method operations can also be performed by, and apparatus of example embodiments may be
20 implemented as, special purpose logic circuitry (e.g., a field programmable gate array (FPGA) or an application-specific integrated circuit (ASIC)).

[00233] The computing system can include clients and servers. A client and server are generally remote from each other and typically interact through a communication network. The relationship of client and server arises by virtue of
25 computer programs running on their respective computers and having a client-server relationship to each other. In embodiments deploying a programmable computing system, it will be appreciated that both hardware and software architectures may be considered. Specifically, it will be appreciated that the choice of whether to implement certain functionality in permanently configured
30 hardware (e.g., an ASIC), in temporarily configured hardware (e.g., a combination of software and a programmable processor), or a combination of permanently and temporarily configured hardware may be a design choice. Below are set forth hardware (e.g., machine) and software architectures that may be deployed in various example embodiments.

EXAMPLE MACHINE ARCHITECTURE AND MACHINE-READABLE MEDIUM

[00234] FIG. 15 is a block diagram of a machine in the example form of a computer system 1500 within which instructions for causing the machine to perform any one or more of the methodologies discussed herein may be executed. In alternative embodiments, the machine operates as a standalone device or may be connected (e.g., networked) to other machines. In a networked deployment, the machine may operate in the capacity of a server or a client machine in a server-client network environment, or as a peer machine in a peer-to-peer (or distributed) network environment. The machine may be a personal computer (PC), a tablet PC, a set-top box (STB), a Personal Digital Assistant (PDA), a cellular telephone, a web appliance, a network router, switch or bridge, or any machine capable of executing instructions (sequential or otherwise) that specify actions to be taken by that machine. Further, while only a single machine is illustrated, the term “machine” shall also be taken to include any collection of machines that individually or jointly execute a set (or multiple sets) of instructions to perform any one or more of the methodologies discussed herein.

[00235] The example computer system 1500 includes a processor 1502 (e.g., a central processing unit (CPU), a graphics processing unit (GPU), or both), a main memory 1504, and a static memory 1506, which communicate with each other via a bus 1508. The computer system 1500 may further include a video display unit 1510 (e.g., a liquid crystal display (LCD) or a cathode ray tube (CRT)). The computer system 1500 also includes an alphanumeric input device 1512 (e.g., a keyboard), a user interface (UI) navigation device 1514 (e.g., a mouse), a disk drive unit 1516, a signal generation device 1518 (e.g., a speaker), and a network interface device 1520.

MACHINE-READABLE MEDIUM

[00236] The disk drive unit 1516 includes a machine-readable medium 1522 on which is stored one or more sets of data structures and instructions 1524 (e.g., software) 1524 embodying or utilized by any one or more of the methodologies or functions described herein. The instructions 1524 may also

reside, completely or at least partially, within the main memory 1504 and/or within the processor 1502 during execution thereof by the computer system 1500, the main memory 1504 and the processor 1502 also constituting machine-readable media.

5 [00237] While the machine-readable medium 1522 is shown in an example embodiment to be a single medium, the term "machine-readable medium" may include a single medium or multiple media (e.g., a centralized or distributed database, and/or associated caches and servers) that store the one or more instructions 1524 or data structures. The term "non-transitory machine-

10 readable medium" shall also be taken to include any tangible medium that is capable of storing, encoding, or carrying instructions for execution by the machine and that cause the machine to perform any one or more of the methodologies of the present subject matter, or that is capable of storing, encoding, or carrying data structures utilized by or associated with such

15 instructions. The term "non-transitory machine-readable medium" shall accordingly be taken to include, but not be limited to, solid-state memories, and optical and magnetic media. Specific examples of non-transitory machine-readable media include, but are not limited to, non-volatile memory, including by way of example, semiconductor memory devices (e.g., Erasable

20 Programmable Read-Only Memory (EPROM), Electrically Erasable Programmable Read-Only Memory (EEPROM), and flash memory devices), magnetic disks such as internal hard disks and removable disks, magneto-optical disks, and CD-ROM and DVD-ROM disks.

25 TRANSMISSION MEDIUM

[00238] The instructions 1524 may further be transmitted or received over a computer network 1550 using a transmission medium. The instructions 1524 may be transmitted using the network interface device 1520 and any one of a number of well-known transfer protocols (e.g., HTTP). Examples of

30 communication networks include a local area network (LAN), a wide area network (WAN), the Internet, mobile telephone networks, Plain Old Telephone Service (POTS) networks, and wireless data networks (e.g., WiFi and WiMAX networks). The term "transmission medium" shall be taken to include any intangible medium that is capable of storing, encoding, or carrying instructions

for execution by the machine, and includes digital or analog communications signals or other intangible media to facilitate communication of such software.

CONCLUSION

5 [00239] Thus, methods and systems to distribute one or more streams of audio data, as well as provide advertising and/or one or more customer-oriented services, have been described. Although the present subject matter has been described with reference to specific example embodiments, it will be evident that various modifications and changes may be made to these embodiments without departing from the broader scope of the subject matter. Accordingly, the specification and drawings are to be regarded in an illustrative rather than a restrictive sense. The accompanying drawings that form a part hereof, show by way of illustration, and not of limitation, specific embodiments in which the subject matter may be practiced. The embodiments illustrated are described in sufficient detail to enable those skilled in the art to practice the teachings disclosed herein. Other embodiments may be utilized and derived therefrom, such that structural and logical substitutions and changes may be made without departing from the scope of this disclosure. This Detailed Description, therefore, is not to be taken in a limiting sense, and the scope of various embodiments is defined only by the appended claims, along with the full range of equivalents to which such claims are entitled.

[00240] Such embodiments of the inventive subject matter may be referred to herein, individually and/or collectively, by the term “invention” merely for convenience and without intending to voluntarily limit the scope of this application to any single invention or inventive concept if more than one is in fact disclosed. Thus, although specific embodiments have been illustrated and described herein, it should be appreciated that any arrangement calculated to achieve the same purpose may be substituted for the specific embodiments shown. This disclosure is intended to cover any and all adaptations or variations of various embodiments. Combinations of the above embodiments, and other embodiments not specifically described herein, will be apparent to those of skill in the art upon reviewing the above description.

[00241] All publications, patents, and patent documents referred to in this document are incorporated by reference herein in their entirety, as though

individually incorporated by reference. In the event of inconsistent usages between this document and those documents so incorporated by reference, the usage in the incorporated reference(s) should be considered supplementary to that of this document; for irreconcilable inconsistencies, the usage in this
5 document controls.

[00242] In this document, the terms “a” or “an” are used, as is common in patent documents, to include one or more than one, independent of any other instances or usages of “at least one” or “one or more.” In this document, the term “or” is used to refer to a nonexclusive “or”, such that “A or B” includes “A
10 but not B,” “B but not A,” and “A and B,” unless otherwise indicated. In the appended claims, the terms “including” and “in which” are used as the plain-English equivalents of the respective terms “comprising” and “wherein.” Also, in the following claims, the terms “including” and “comprising” are open-ended; that is, a system, device, article, or process that includes elements in addition to
15 those listed after such a term in a claim are still deemed to fall within the scope of that claim. Moreover, in the following claims, the terms “first,” “second,” “third,” and so forth are used merely as labels and are not intended to impose numerical requirements on their objects.

[00243] The Abstract of the Disclosure is provided to comply with 37
20 C.F.R. § 1.72(b), requiring an abstract that will allow the reader to quickly ascertain the nature of the technical disclosure. The Abstract is submitted with the understanding that it will not be used to interpret or limit the scope or meaning of the claims. In addition, in the foregoing Detailed Description, it can be seen that various features are grouped together in a single embodiment for the
25 purpose of streamlining the disclosure. This method of disclosure is not to be interpreted as reflecting an intention that the claimed embodiments require more features than are expressly recited in each claim. Rather, as the following claims reflect, inventive subject matter lies in less than all features of a single disclosed embodiment. Thus the following claims are hereby incorporated into the
30 Detailed Description, with each claim standing on its own as a separate embodiment.

CLAIMS

What is claimed is:

1. A system comprising:
5 an access device; and
a plurality of audio relay devices, each audio relay device to:
receive from a video presentation device an audio signal
corresponding to video content being presented by the video presentation device;
and
10 transmit a digital audio stream representing the audio signal to the
access device;
the access device to:
receive each of the digital audio streams from the plurality of
audio relay devices; and
15 transmit wirelessly the received digital audio streams to a mobile
communication device.
2. The system of claim 1, the plurality of audio relay devices, the access
20 device, and the mobile communication device being located within a single
venue.
3. The system of claim 1, further comprising:
a communication node to transmit additional content to the access device,
the access device to transmit the received additional content wirelessly to the
25 mobile communication device.
4. The system of claim 3, the additional content being based on at least one
of a venue or a geographic location in which the access device is located.
- 30 5. The system of claim 3, the additional content being based on one of the
digital audio streams transmitted to the mobile communication device that is
selected by a user of the mobile communication device for reception.

6. The system of claim 3, the additional content being based on profile information of a user of the mobile communication device.
7. The system of claim 3, the additional content comprising information for
5 at least one of point-of-sale transactions, mobile commerce transactions, a gaming service, a customer loyalty service, and a social networking service.
8. The system of claim 1, further comprising a communication node to
10 receive additional content from the access device, the access device to receive the additional content wirelessly from the mobile communication device.
9. The system of claim 1, each of the plurality of audio relay devices to
15 operate as an appliance of a communication network, the plurality of audio relay devices to transmit the digital audio streams to the access device via the communication network.
10. An access device comprising:
at least one receiver to receive a plurality of digital audio streams, each
20 of the digital audio streams representing an audio signal corresponding to video content being presented by a video presentation device; and
a wireless transceiver to transmit, to at least one mobile communication
device for presentation to a user, a plurality of wireless digital audio streams,
each of the wireless digital audio streams corresponding to one of the received
25 digital audio streams.
11. The access device of claim 10, the at least one receiver comprising a
plurality of digital audio receivers, each of the digital audio receivers to receive
one of the digital audio streams.
- 30 12. The access device of claim 10, the at least one receiver comprising a receiver for a local area network, the receiver to receive each of the plurality of digital audio streams via the local area network.
13. The access device of claim 10, further comprising:

a communication network interface to facilitate communication with a communication node via a wide area network.

14. The access device of claim 13, the wireless transceiver to transmit and receive additional content between the communication network interface and the at least one mobile communication device.

15. The access device of claim 13, the communication network interface to receive at least one additional digital audio stream from the communication node, the at least one additional digital audio stream representing an audio signal corresponding to video content being presented by another video presentation device to the user, the wireless transceiver to transmit, to the at least one mobile communication device for presentation to the user, the at least one additional digital audio stream.

15

16. The access device of claim 10, further comprising control logic to transmit identifying information for the video presentation device associated with each of the plurality of wireless digital audio streams via the wireless transceiver to the at least one mobile communication device.

20

17. An audio relay device, comprising:

an audio receiver to receive an audio signal from a video presentation device, the audio signal corresponding to video content being presented by the video presentation device; and

a digital audio transmitter to transmit a digital audio stream based on the received audio signal to an access device for distribution to at least one mobile communication device for presentation to a user.

30

18. The audio relay device of claim 17, the received audio signal comprising an analog audio signal, the device further comprising a conversion module to convert the analog audio signal to the digital audio stream transmitted by the digital audio transmitter.

19. The audio relay device of claim 18, the conversion module to compress the digital audio stream prior to the digital audio transmitter transmitting the digital audio stream.

5

20. The audio relay device of claim 17, the audio receiver being physically coupled to an audio output of the video presentation device to receive the audio signal.

10 21. The audio relay device of claim 17, the digital audio transmitter comprising a transceiver for a local area network.

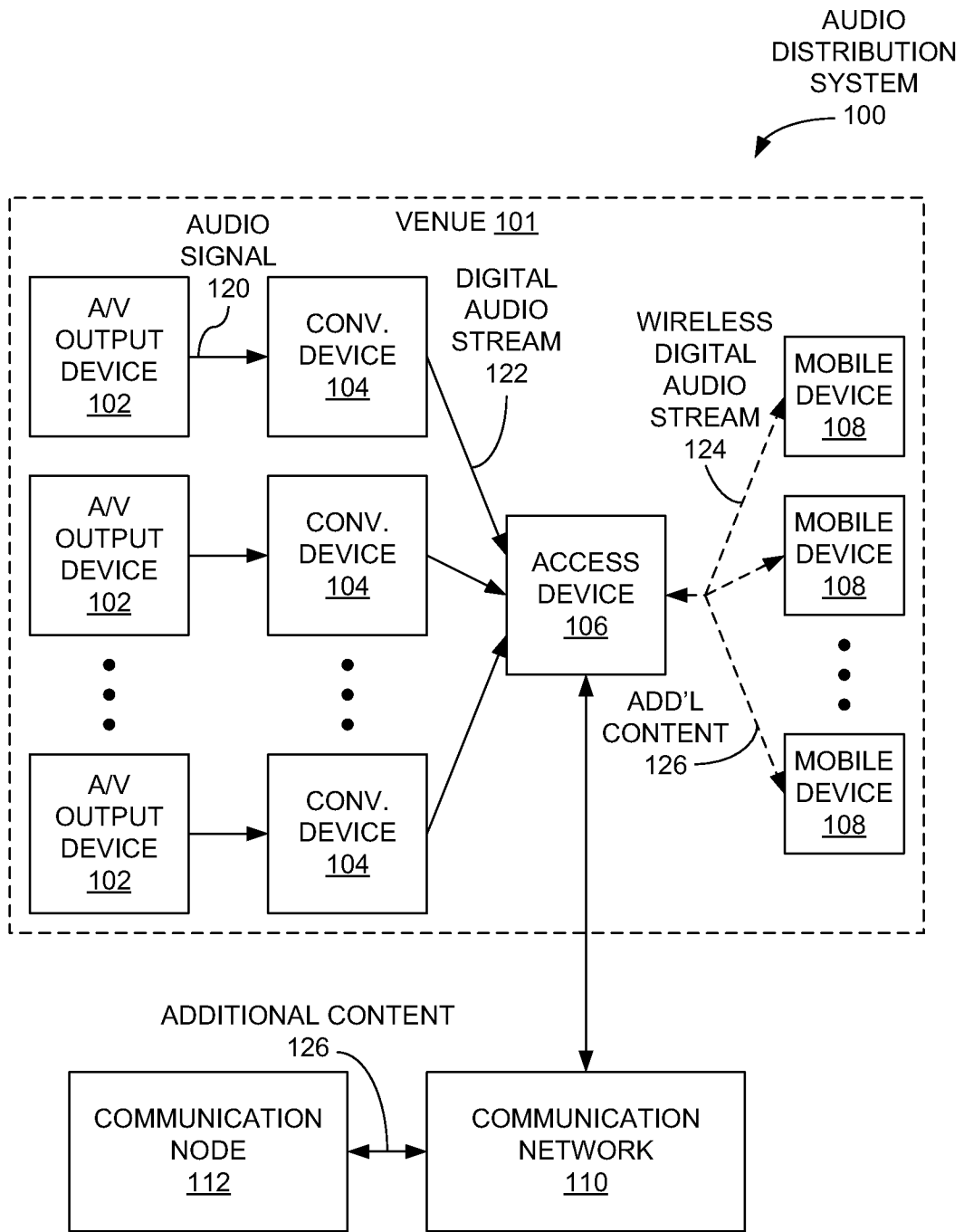

FIG. 1

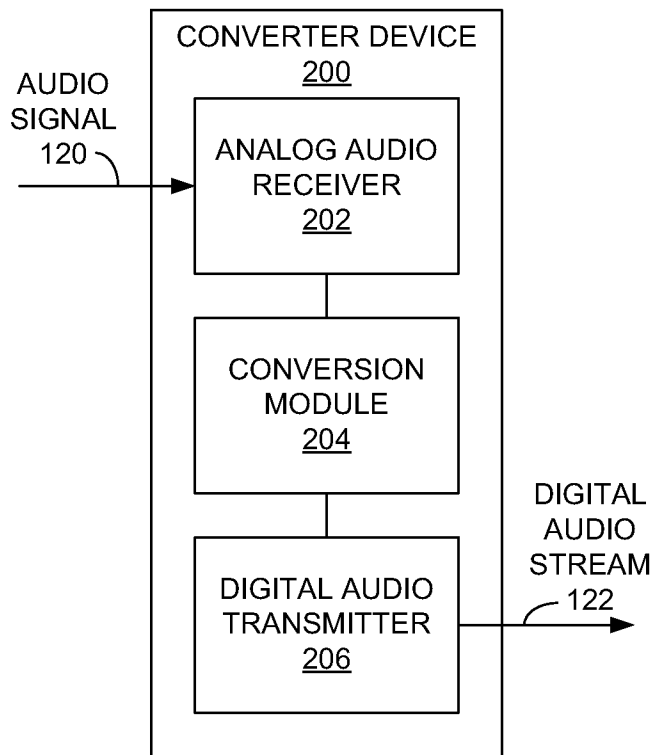

FIG. 2

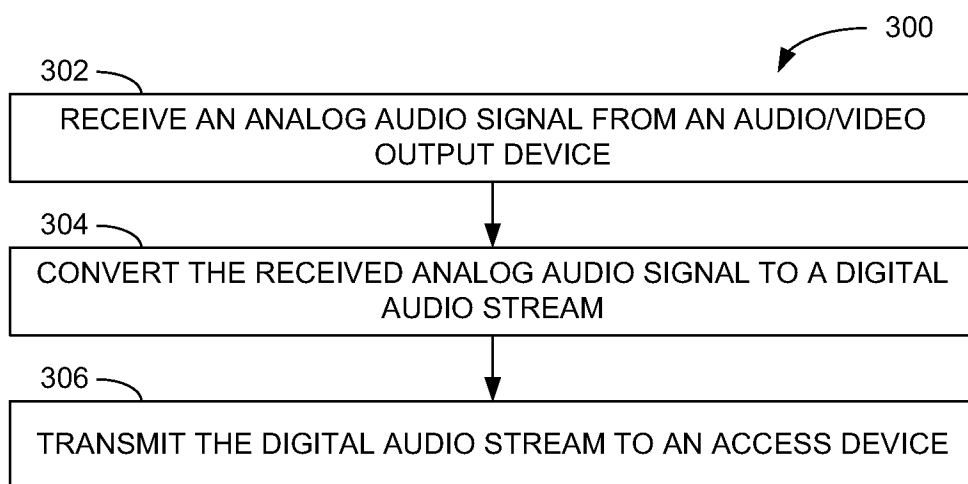

FIG. 3

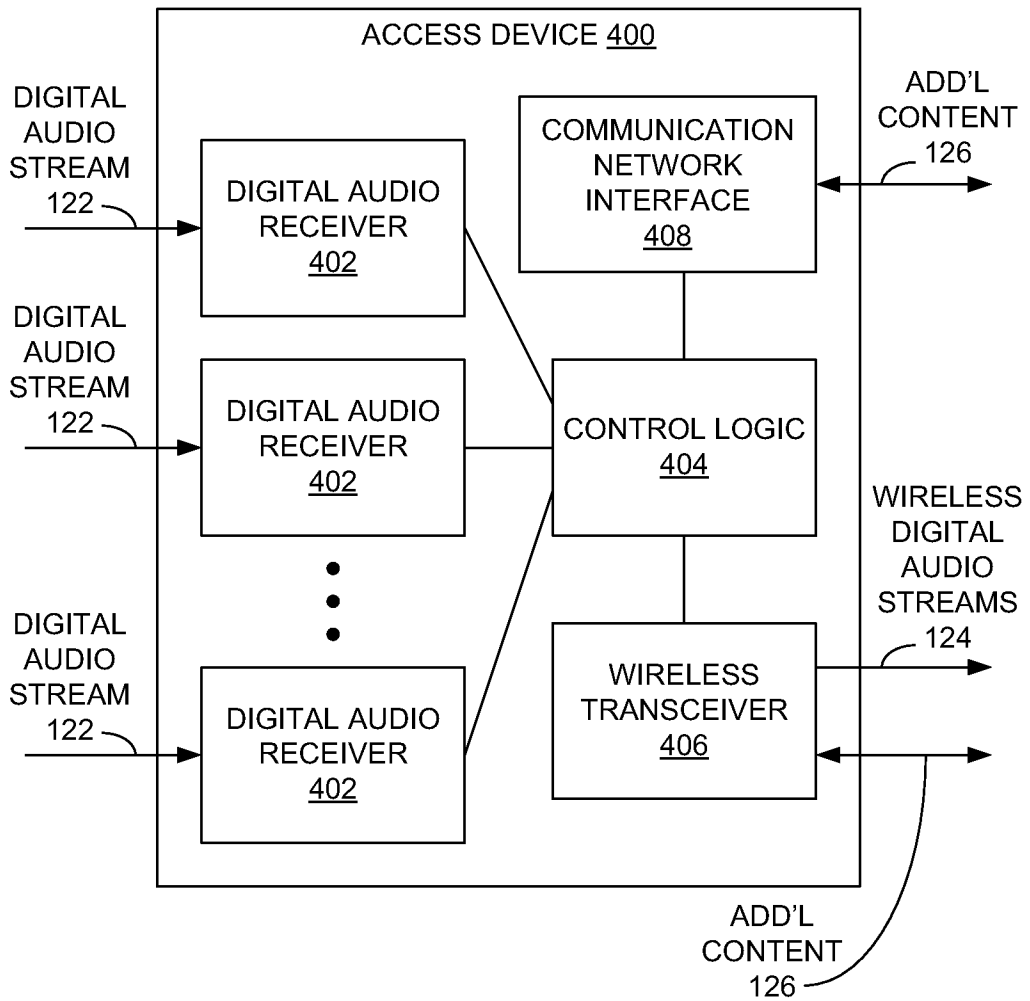

FIG. 4

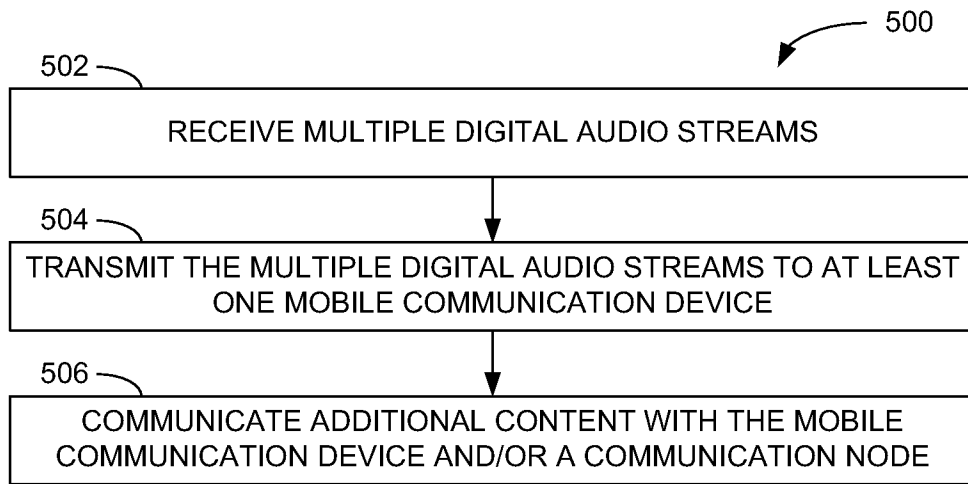

FIG. 5

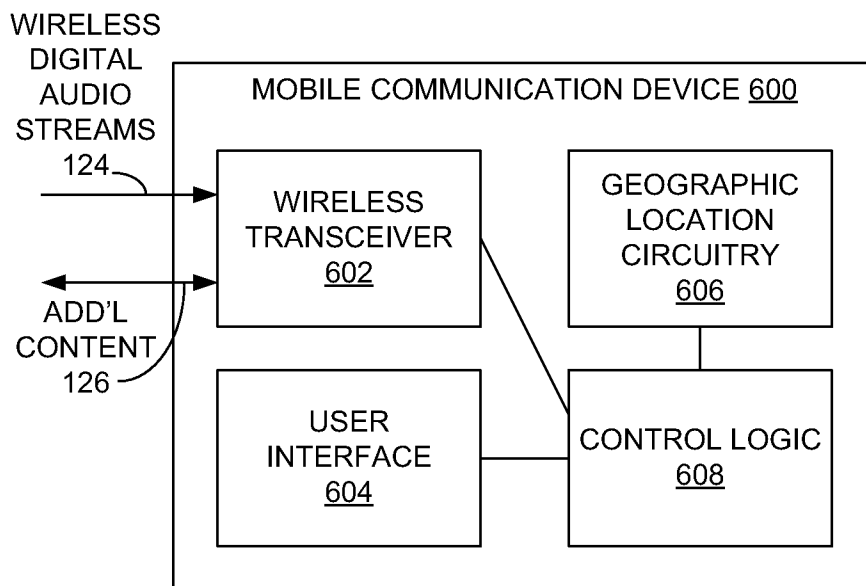

FIG. 6

7/15

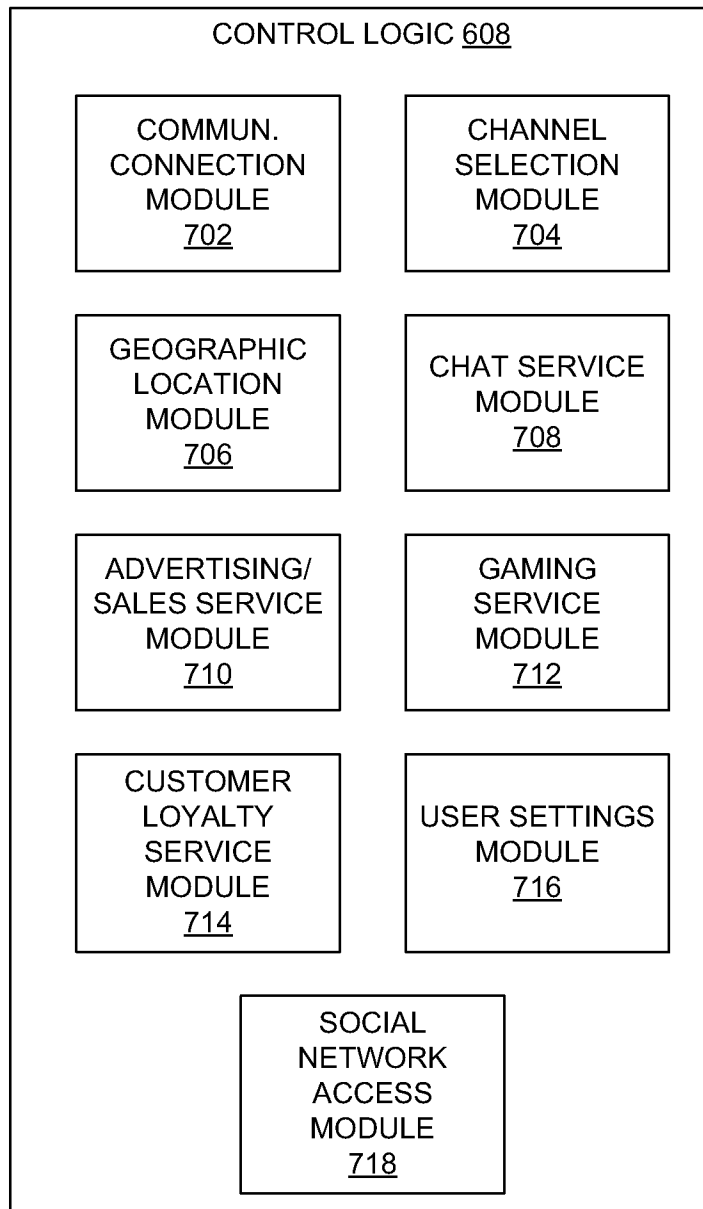

FIG. 7

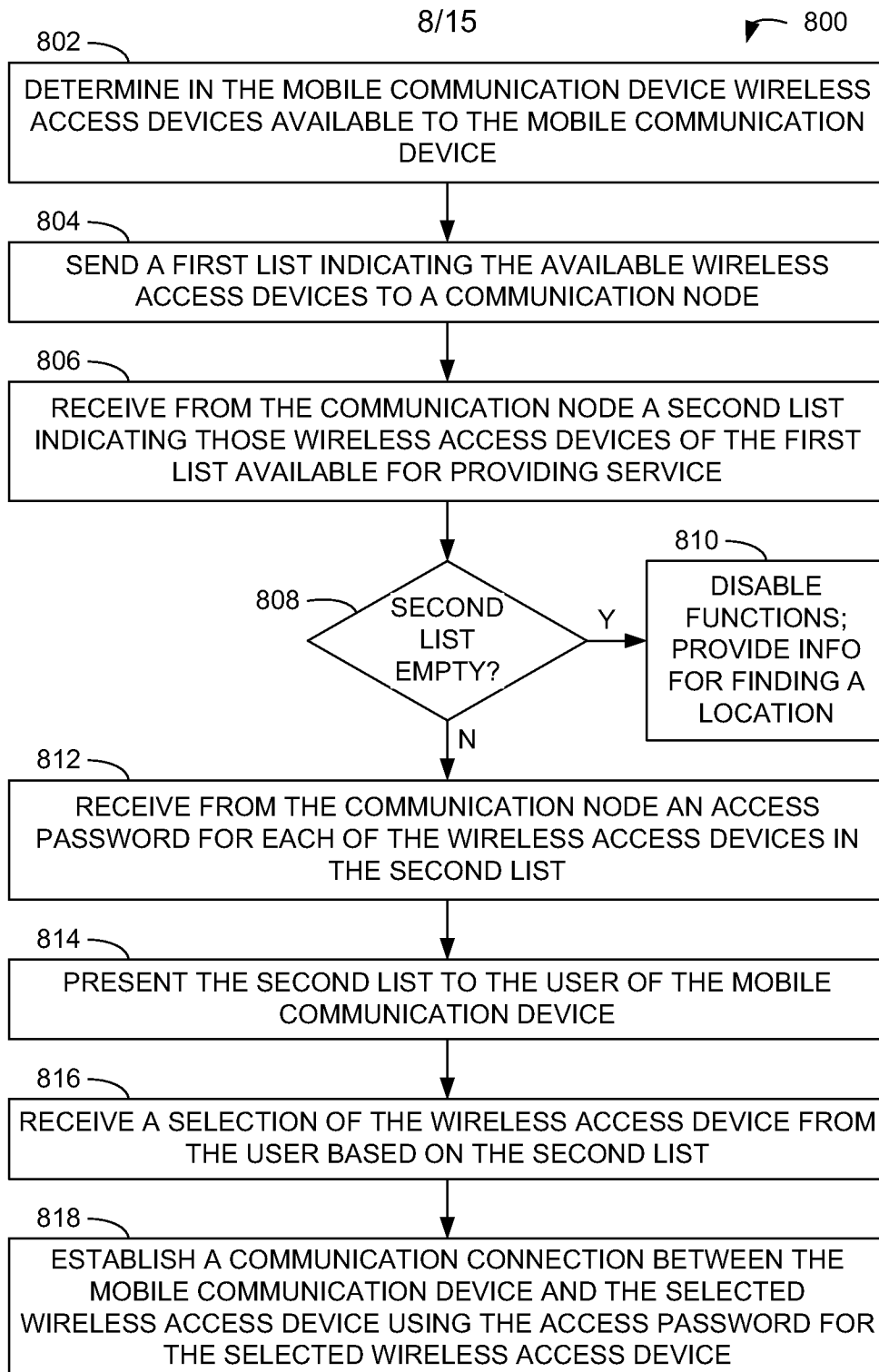
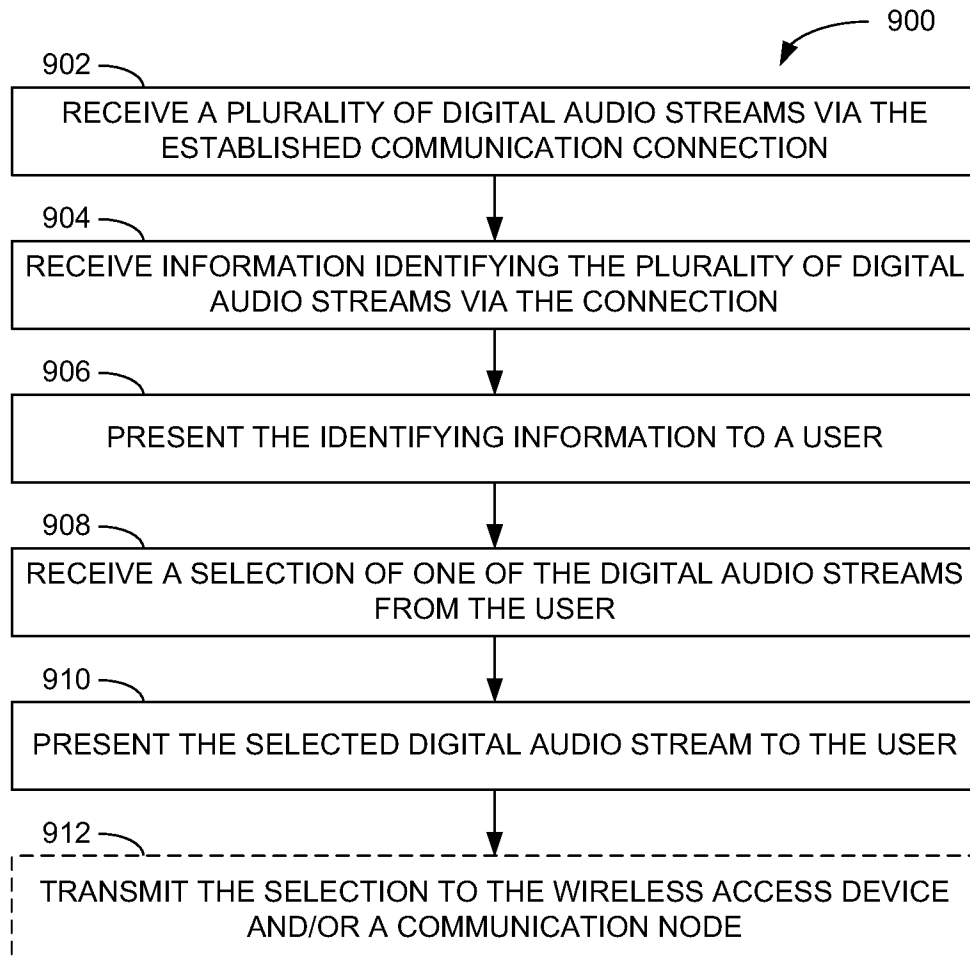

FIG. 8

9/15

**FIG. 9**

10/15

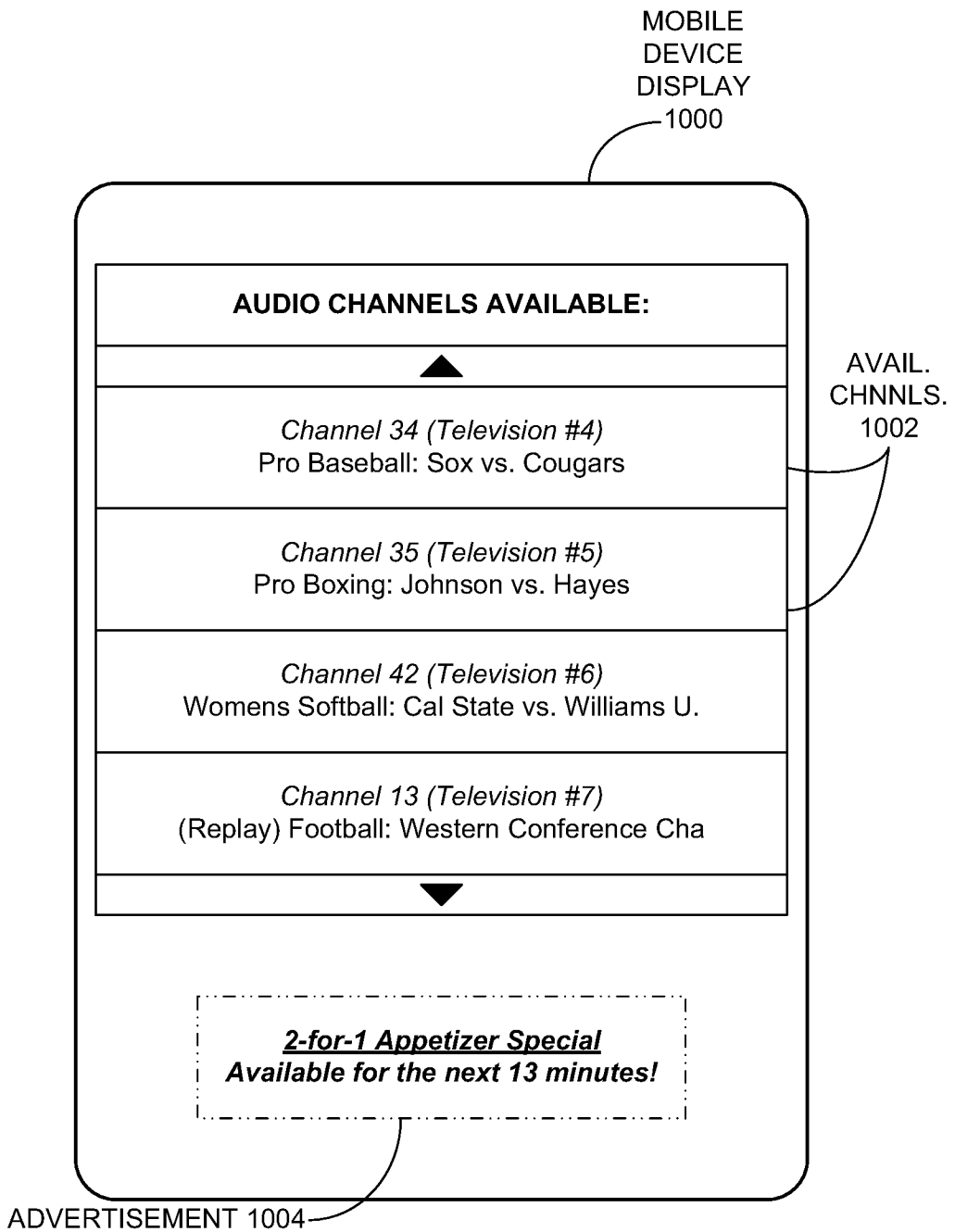

FIG. 10

11/15

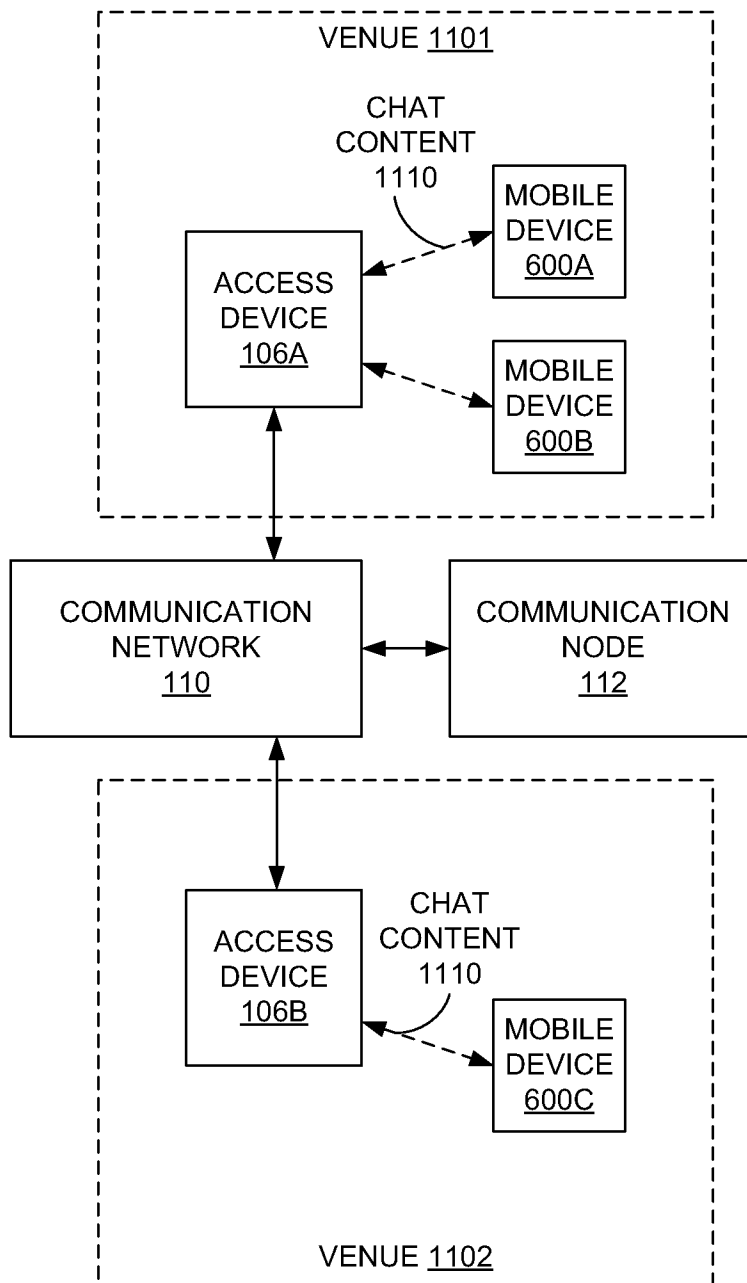

FIG. 11

12/15

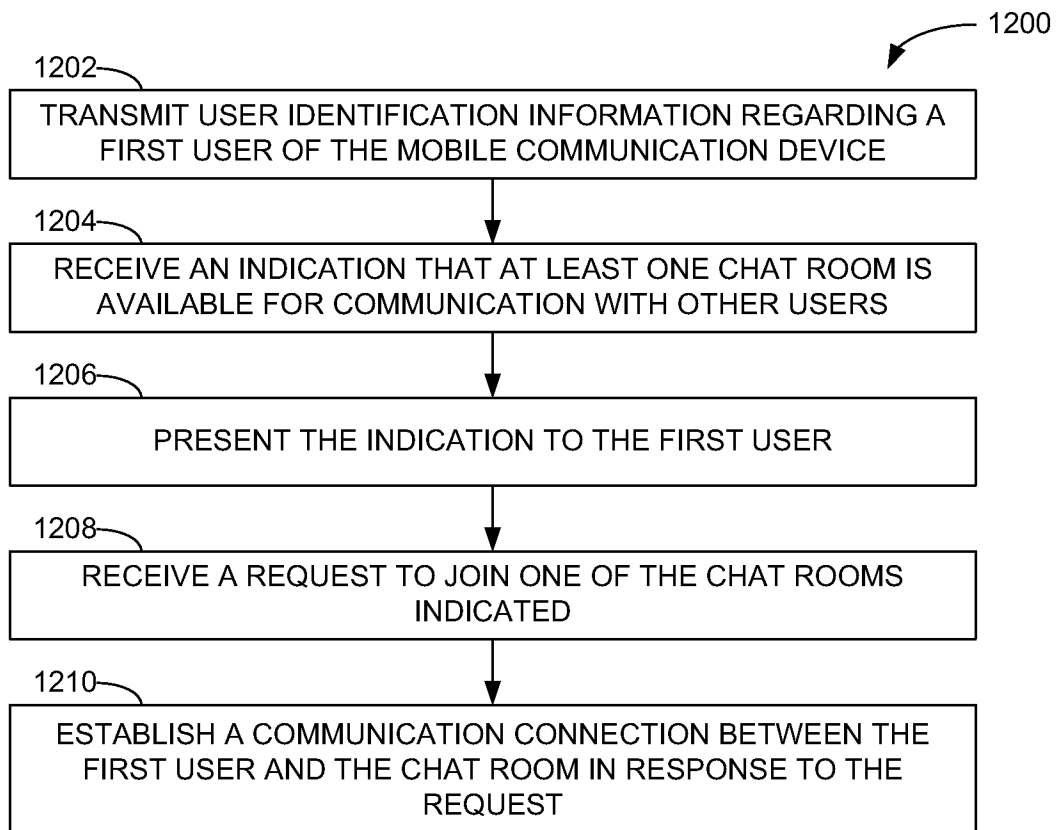
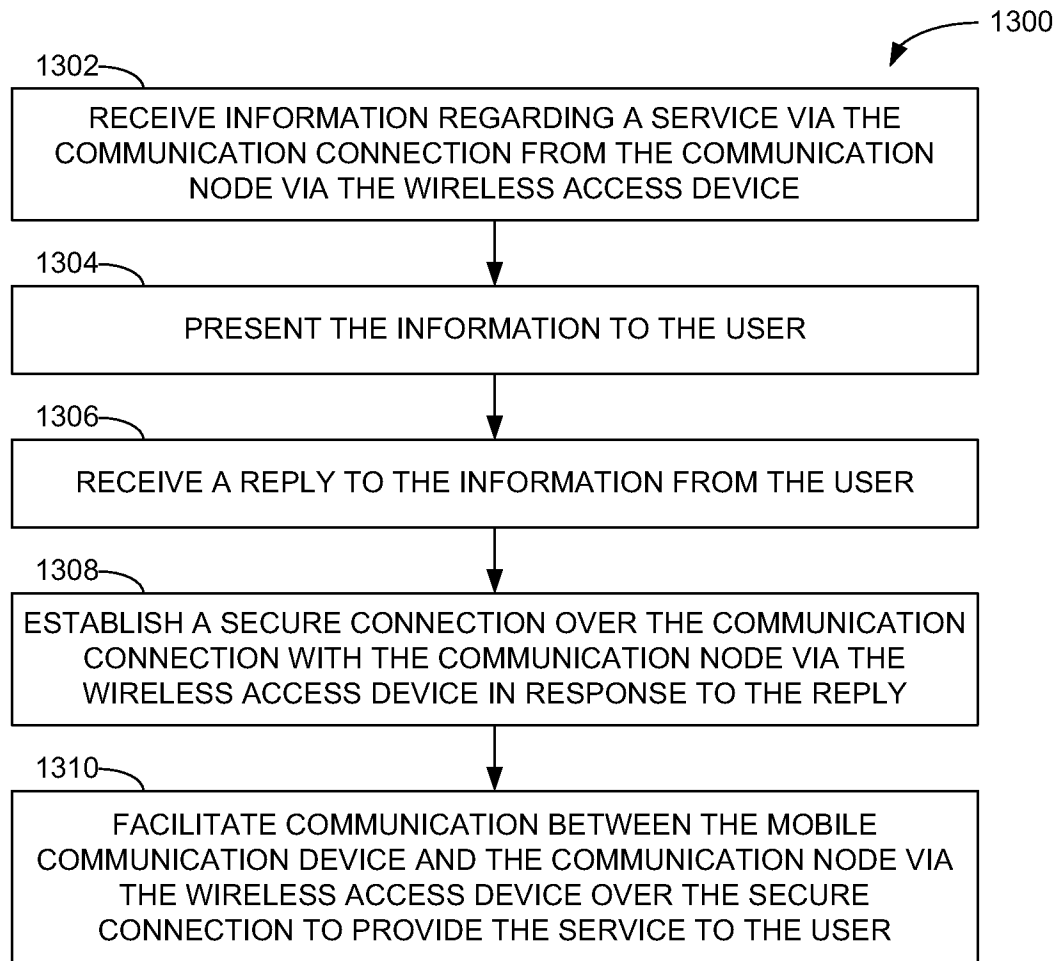

FIG. 12

13/15

**FIG. 13**

14/15

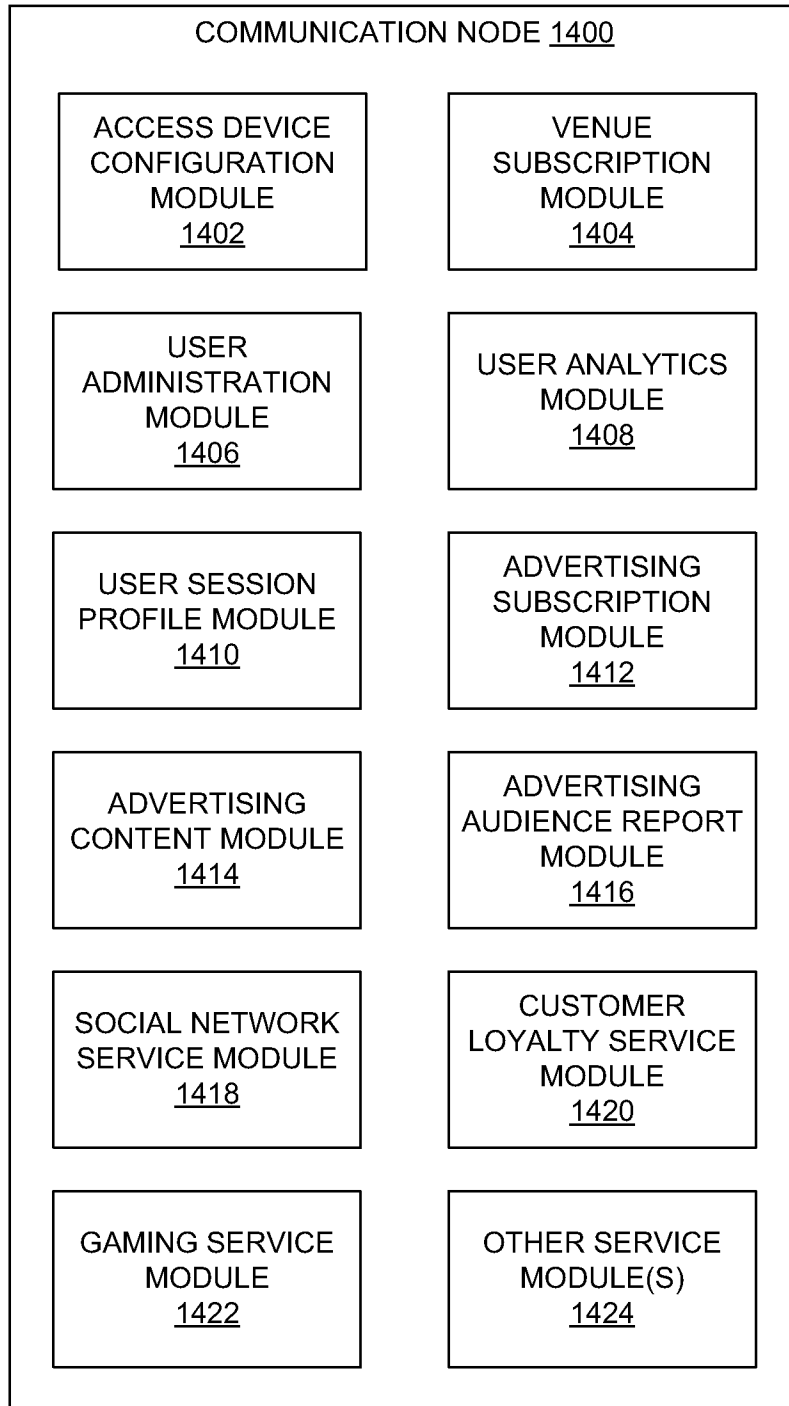

FIG. 14

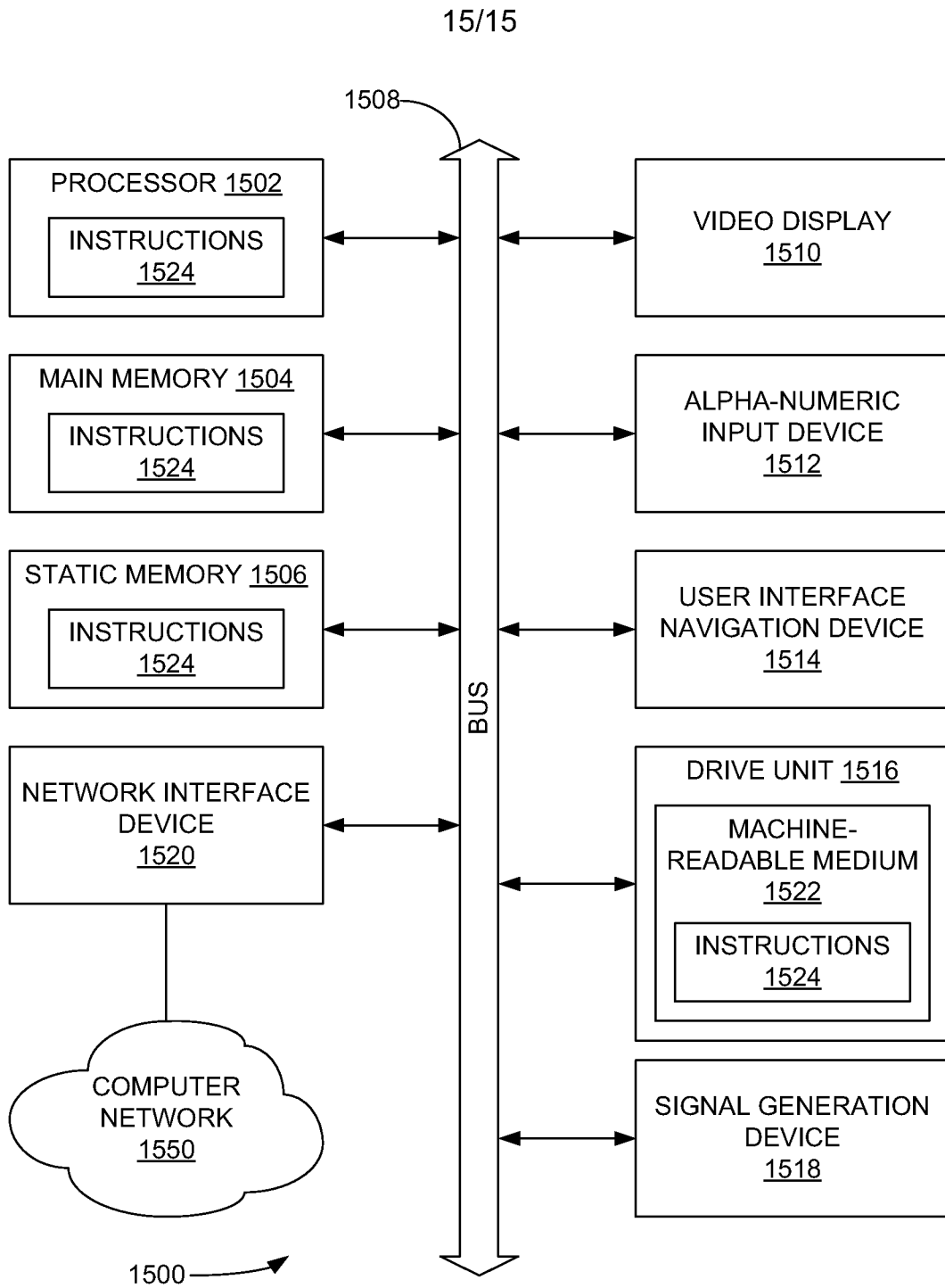

FIG. 15

INTERNATIONAL SEARCH REPORT

International application No.

PCT/US 12/40559

A. CLASSIFICATION OF SUBJECT MATTER
 IPC(8) - H04B 1/20 (2012.01)
 USPC - 340/4.42
 According to International Patent Classification (IPC) or to both national classification and IPC

B. FIELDS SEARCHED

Minimum documentation searched (classification system followed by classification symbols)
 USPC: 340/4.42; IPC(8): H04B 1/20 (2012.01)

Documentation searched other than minimum documentation to the extent that such documents are included in the fields searched
 USPC: 340/4.4 (see terms below)

Electronic data base consulted during the international search (name of data base and, where practicable, search terms used)
 PubWEST(PGPB,USPT,USOC,EPAB,JPAB), GOOGLE SCHOLAR
 terms: access, audio, sound, music, speech, voice, spoken, video, image, convert, relay, communication, venue, geographic, restaurant, drink, bar, pub, TV, television, sale, commerce, transaction, gaming, social, loyalty, local area network, LAN, Wi-Fi, mobile, cellular

C. DOCUMENTS CONSIDERED TO BE RELEVANT

Category*	Citation of document, with indication, where appropriate, of the relevant passages	Relevant to claim No.
X --- Y	US 2007/0058041 A1 (Arseneau et al.) 15 March 2007 (15.03.2007), fig. 1-2, para [0033], [0046]-[0059], [0073]-[0076], [0095]-[0098], [0110]-[0121], [0161], [0312], [0341]-[0344], [0398].	1-8, 10-11, 13-21 ----- 9, 12
Y	US 6,185,737 B1 (Northcutt et al.) 06 February 2001 (06.02.2001), fig. 1, col 2, ln 29-65, col 3, ln 29-44, col 5, ln 52-64, col 7, ln 44-60.	9, 12
A	US 6,300,880 B1 (Sitnik) 09 October 2001 (09.10.2001), entire document.	1-21

Further documents are listed in the continuation of Box C.

* Special categories of cited documents:
 "A" document defining the general state of the art which is not considered to be of particular relevance
 "E" earlier application or patent but published on or after the international filing date
 "L" document which may throw doubts on priority claim(s) or which is cited to establish the publication date of another citation or other special reason (as specified)
 "O" document referring to an oral disclosure, use, exhibition or other means
 "P" document published prior to the international filing date but later than the priority date claimed
 "T" later document published after the international filing date or priority date and not in conflict with the application but cited to understand the principle or theory underlying the invention
 "X" document of particular relevance; the claimed invention cannot be considered novel or cannot be considered to involve an inventive step when the document is taken alone
 "Y" document of particular relevance; the claimed invention cannot be considered to involve an inventive step when the document is combined with one or more other such documents, such combination being obvious to a person skilled in the art
 "&" document member of the same patent family

Date of the actual completion of the international search 12 August 2012 (12.08.2012)	Date of mailing of the international search report 04 SEP 2012
--	--

Name and mailing address of the ISA/US Mail Stop PCT, Attn: ISA/US, Commissioner for Patents P.O. Box 1450, Alexandria, Virginia 22313-1450 Facsimile No. 571-273-3201	Authorized officer: Lee W. Young PCT Helpdesk: 571-272-4300 PCT OSP: 571-272-7774
---	--