



- (51) International Patent Classification:
F25C 5/20 (2018.01) *F25D 17/08* (2006.01)
F25D 17/06 (2006.01)
- (21) International Application Number:
PCT/US2018/029004
- (22) International Filing Date:
24 April 2018 (24.04.2018)
- (25) Filing Language: English
- (26) Publication Language: English
- (30) Priority Data:
15/497,274 26 April 2017 (26.04.2017) US
- (71) Applicant: **ELECTROLUX HOME PRODUCTS, INC.**
[US/US]; 10200 David Taylor Drive, Charlotte, NC 28262 (US).
- (72) Inventors: **OLVERA, Jose Carlos Trejo**; 101 Masters Boulevard, Anderson, SC 29624 (US). **MCCOLLOUGH, Thomas**; 101 Masters Boulevard, Anderson, SC 29624 (US). **COMSA, Cornel**; 101 Masters Boulevard, Anderson, SC 29624 (US). **BERTOLINI, Nilton Carlos**; 101 Masters Boulevard, Anderson, SC 29624 (US).
- (74) Agent: **GALLO, Bryan M.** et al.; Pearne & Gordon, LLP, 1801 East Ninth Street, Suite 1200, Cleveland, OH 44114-3108 (US).
- (81) Designated States (*unless otherwise indicated, for every kind of national protection available*): AE, AG, AL, AM, AO, AT, AU, AZ, BA, BB, BG, BH, BN, BR, BW, BY, BZ, CA, CH, CL, CN, CO, CR, CU, CZ, DE, DJ, DK, DM, DO, DZ, EC, EE, EG, ES, FI, GB, GD, GE, GH, GM, GT, HN, HR, HU, ID, IL, IN, IR, IS, JO, JP, KE, KG, KH, KN, KP, KR, KW, KZ, LA, LC, LK, LR, LS, LU, LY, MA, MD, ME, MG, MK, MN, MW, MX, MY, MZ, NA, NG, NI, NO, NZ, OM, PA, PE, PG, PH, PL, PT, QA, RO, RS, RU, RW, SA, SC, SD, SE, SG, SK, SL, SM, ST, SV, SY, TH, TJ, TM, TN, TR, TT, TZ, UA, UG, US, UZ, VC, VN, ZA, ZM, ZW.
- (84) Designated States (*unless otherwise indicated, for every kind of regional protection available*): ARIPO (BW, GH, GM, KE, LR, LS, MW, MZ, NA, RW, SD, SL, ST, SZ, TZ, UG, ZM, ZW), Eurasian (AM, AZ, BY, KG, KZ, RU, TJ, TM), European (AL, AT, BE, BG, CH, CY, CZ, DE, DK, EE, ES, FI, FR, GB, GR, HR, HU, IE, IS, IT, LT, LU, LV, MC, MK, MT, NL, NO, PL, PT, RO, RS, SE, SI, SK, SM, TR), OAPI (BF, BJ, CF, CG, CI, CM, GA, GN, GQ, GW, KM, ML, MR, NE, SN, TD, TG).

(54) Title: REFRIGERATION APPLIANCE WITH A COLD AIR SUPPLY FOR AN ICE MAKER AND WITH AN ICE LEVEL SENSOR

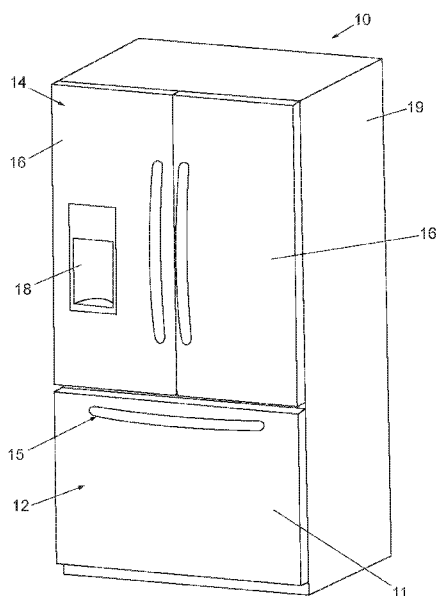

FIG. 1

(57) Abstract: A refrigeration appliance (10) includes an ice maker (50) disposed in a fresh food compartment (14). An air handler assembly (100) conveys cooling air through the ice maker (50). An insulated air duct (152) is disposed between an evaporator (186) and a fan (164) for preventing the migration of ice from the evaporator (186) to the fan (164). The insulated duct (152) has an opening extending from an end adjacent the evaporator (186) to an end adjacent the fan (164). A lower inner wall of the air duct (152) has a first ramped portion (156a) on the end adjacent the evaporator (186). In another example, the icemaker (350) includes a sensor assembly (370) positioned to detect a level of ice (352) in the ice bin (354). The sensor assembly (370) includes an emitter (372) for sending photons along a predetermined path, and a receiver (374) for detecting the photons when the photons are reflected off an object disposed in the predetermined path.

WO 2018/200433 A4

Published:

- *with international search report (Art. 21(3))*
- *with amended claims (Art. 19(1))*

Date of publication of the amended claims:

27 December 2018 (27.12.2018)

AMENDED CLAIMS

received by the International Bureau on 21 November 2018 (21.11.2018)

Listing of Claims:

1. A refrigeration appliance comprising:
 - a fresh food compartment for storing food items in a refrigerated environment having a target temperature above zero degrees Centigrade; and
 - an ice maker disposed within the fresh food compartment for producing and storing ice pieces, the ice maker comprising:
 - an ice tray for forming ice pieces,
 - an ice bin for receiving and storing ice pieces produced by the ice tray,
 - an evaporator for cooling air conveyed through the ice tray and the ice bin, and
 - an air handler assembly for conveying cooling air through the ice tray and the ice bin, the air handler assembly comprising:
 - a fan for conveying the cooled air, and
 - an air duct disposed between the evaporator and the fan for preventing migration of ice from the evaporator to the fan, the air duct having an opening extending from an end adjacent the evaporator to an end adjacent the fan and a lower inner wall of the air duct have a first downward ramped portion on the end adjacent the evaporator and a second downward ramped portion on the end adjacent the fan, wherein the second downward ramped portion is shorter than the first downward ramped portion.
2. (Canceled)
3. (Canceled)
4. The refrigeration appliance of claim 1, wherein a slope of the second downward ramped portion is greater than a slope of the first downward ramped portion.

5. The refrigeration appliance of claim 1, wherein at least one of the first downward ramped portion and the second downward ramped portion is curved.
6. The refrigeration appliance of claim 5, wherein the air duct is about 3 inches in length.
7. The refrigeration appliance of claim 1, wherein at least one of the first downward ramped portion and the second downward ramped portion is planar.
8. The refrigeration appliance of claim 1, wherein the air duct is made from an insulating material.
9. The refrigeration appliance of claim 1, wherein the air duct is between about 2 inches and about 5 inches in length.
10. The refrigeration appliance of claim 1, wherein an opening is formed between the air duct and the fan.
11. The refrigeration appliance of claim 10, wherein the opening is defined by a notch formed in a leading edge of the air duct.
12. An ice maker for freezing water into ice pieces, the ice maker comprising:
 - an ice tray for forming ice pieces,
 - an ice bin for receiving and storing ice pieces produced by the ice tray,
 - an evaporator for cooling air conveyed through the ice tray and the ice bin, and
 - an air handler assembly for conveying cooling air through the ice tray and the ice bin, the air handler assembly comprising:
 - a fan for conveying the cooled air, and
 - an air duct disposed between the evaporator and the fan for preventing migration of ice from the evaporator to the fan, the air duct having an opening extending from an end adjacent the evaporator to an end adjacent the fan and a lower inner wall of the air duct have a first

downward ramped portion on the end adjacent the evaporator and a second downward ramped portion on the end adjacent the fan, wherein the second downward ramped portion is shorter than the first downward ramped portion.

13. (Canceled)

14. (Canceled)

15. The ice maker of claim 12, wherein a slope of the second downward ramped portion is greater than a slope of the first downward ramped portion.

16. The ice maker of claim 12, wherein at least one of the first downward ramped portion and the second downward ramped portion is at least one of curved or planar.

17. The ice maker of claim 12, further comprising at least one of the following:
the evaporator including a metal housing defining a flow path through the evaporator, and
the air handler assembly including a housing having an open end and an over-molded gasket disposed around a periphery of the open end of the housing.

18. An ice maker for freezing water into ice pieces, the ice maker comprising:
an ice tray for forming ice pieces
an ice bin for receiving and storing ice pieces produced by the ice tray,
a sensor assembly positioned to detect a level of ice in the ice bin, the sensor assembly comprising:
an emitter for sending photons along a predetermined path, and
a receiver for detecting the photons when the photons are reflected off an object disposed in the predetermined path, and
a controller programmed to measure a duration of time between the emitter sending the photon along the predetermined path and the receiver

detecting the photon to determine at least one of a height of the ice pieces in the ice bin and a presence/absence of the ice bin in the ice maker based on input from the emitter and the receiver.

19. The ice maker of claim 18, further comprising a housing for the sensor assembly, wherein both of the emitter and the receiver are disposed in the housing.

20. The ice maker of claim 18, wherein the sensor assembly is positioned above the ice bin.