

(No Model.)

S. N. EISLER.
ROTARY PUMP.

No. 522,518.

Patented July 3, 1894.

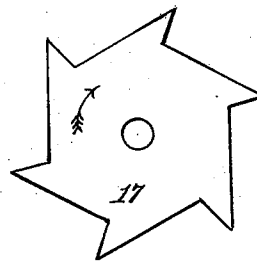
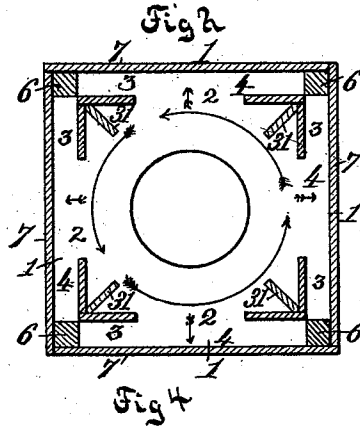
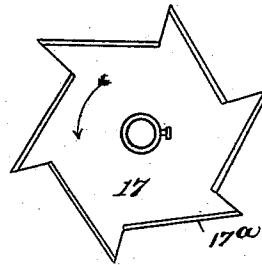
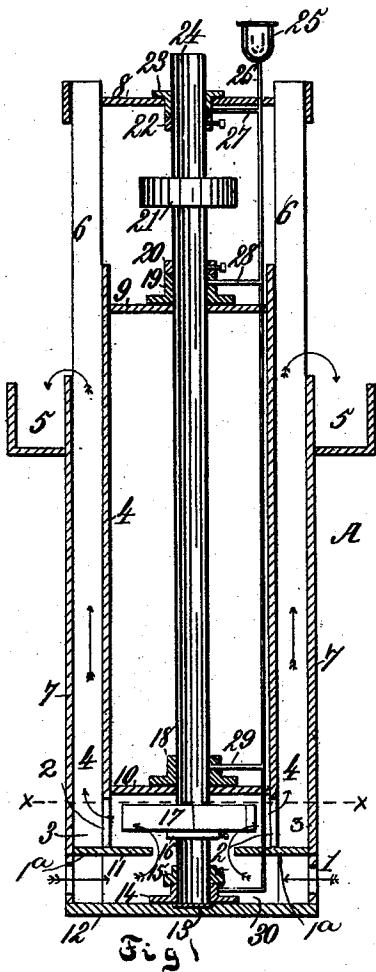

Witnesses
Robert E. Rice
Sidney G. Cook

Inventor.
Stephen Eisler

By *Walter H. Cook*
Attorney.

UNITED STATES PATENT OFFICE.

STEPHEN N. EISLER, OF NEW ORLEANS, LOUISIANA, ASSIGNOR OF ONE-HALF
TO JOHN D. BELTON AND SHAKESPEARE & SWOOP, OF SAME PLACE.

ROTARY PUMP.

SPECIFICATION forming part of Letters Patent No. 522,518, dated July 3, 1894.

Application filed June 15, 1893. Serial No. 477,745. (No model.)

To all whom it may concern:

Be it known that I, STEPHEN N. EISLER, a citizen of the United States, residing at New Orleans, in the parish of Orleans and State of Louisiana, have invented certain new and useful Improvements in Rotary Pumps; and I do hereby declare that the following is a full, clear, and exact description of the same, reference being had to the annexed drawings, making a part of this specification, and to the letters and figures of reference marked thereon.

My invention relates to certain improvements in rotary pumps, and has for its objects to provide a novel construction and combination of parts whereby the forcing of the water upward to the point of delivery is insured, and to provide novel means for oiling or lubricating the parts of the structure without dismemberment and while in operation.

To these ends my said invention consists in the novel construction and combination or arrangement of parts hereinafter described and claimed, reference being made to the accompanying drawings, in which—

Figure 1, is a vertical section of a pump constructed in accordance with my invention. Fig. 2, is a bottom plan view of the lift and force piston. Fig. 3, is a top plan view of the same, and Fig. 4, is a sectional view, taken on the line $x-x$, the piston being shown in dotted lines.

In the said drawings, the letter A, indicates the pump-casing or framing, which is composed of a bottom or base-piece 12, from the four corners of which rise standards or beams 6, secured to which are interior and exterior walls 4 and 7, which are separated from each other to provide water-passage-ways or conduits 3, of which four are shown in the drawings, (see Fig. 4.) The interior walls 4, extend upward beyond the exterior walls 7, as in Fig. 1, to prevent the water passing up the conduit 3 from overflowing into the interior of the casing or framing A.

Secured to the exterior walls 7, at or near their top edges is a trough 5, of which there may be four, one to receive the water flowing from each conduit or passage 3, or one continuous trough extending around the casing A may be provided. This trough or troughs receive the water from the conduits 3, and

may be suitably connected with means of conveyance, (not shown herein and forming no part of the invention,) for carrying the water to any desired point of use. 55

The numeral 24, designates a shaft vertically arranged within the pump-casing A. At its lower end, this shaft rests upon a steel plate 13, set into the base-piece 12, and revolves or rotates in a bearing 14. 60

A collar or cap 15 is secured by a set-crew to the shaft 24, and lies upon the top edge of the bearing 14, preventing the access of sand or other foreign matter to the bearing of the shaft. The shaft is supported and steadied laterally by floors or partitions 8, 9 and 10, arranged at suitable intervals vertically, and provided with openings through which the shaft 24 passes, and bearings 19 and 23, arranged in connection with the floors or partitions 8 and 9. In order to retain the shaft in proper vertical position for operation and prevent any vertical movement which might otherwise be induced by the work performed, I firmly secure collars 20 and 22, to the shaft by set screws said collars being arranged in contact with the bearings 19 and 23, as shown in the drawings, one of said collars being arranged above the bearing 19 and the other below the bearing 23; in this manner it will be seen that the shaft is prevented from any vertical displacement or movement. 75 80

In prior pumping-apparatus it has been difficult and inconvenient to lubricate the bearings of the propelling shaft, since it was essential that parts of the structure be removed for that purpose. By my invention, I avoid the inconvenience and provide a novel lubricating means by which the shaft-bearings can be lubricated automatically so long as the supply of oil lasts, and whereby oil can be supplied without dismemberment of the apparatus, said means consisting of a vertical pipe 26, arranged interiorly of the pump-casing as shown and communicating at its upper end with the outlet of an oil supply-cup 25. 85 90 95

Branch pipes 27 extend from the vertical pipe 26 and lead to the shaft-bearings 14, 18, 19 and 22, so that the oil or lubricant is automatically fed to said bearings. The oil supply-cup 25 is arranged so that oil can be 100

placed therein without taking apart the casing or any of the supports of the shaft.

A water-inlet opening 1, is provided at the bottom of the casing A, which extends on all sides of said casing, and extending inwardly in said casing immediately over said opening is an intercepting-plate 1^a, above which an opening 2, is provided in the inner wall 4, of the casing, leading to the passage or conduit 3.

The numeral 17, designates a combined lift and force piston which is secured to the shaft 24, so as to rotate therewith, by means of a set screw, or in any other suitable manner said piston being located in the compartment formed by the partition 10 and the intercepting plates 1^a, the form thereof being illustrated in Figs. 2 and 3, wherein it is shown as a solid piece of material, the periphery or edge being shaped or formed into a series of inclined pushing surfaces 17^a. The shaft 24 is rotated by means of a belt (not shown) running upon the pulley 21, and driven from any suitable source of power. When the shaft 24 is rotated, the piston 17 is also rotated in the direction shown by the arrows, Fig. 4, and by its action draws water in through the opening 1, lifts it up around the intercepting plates 1^a and by means of the inclined pushing faces 17^a forces it radially outward into the passage or conduit 3 through the opening 2, the water being guided into or compelled to enter the passage 3, by cut-offs 31, located at the four corners of the casing in the same horizontal plane with the openings 2. In the absence of these cut-offs the water would probably travel around with the wheel in a horizontal direction, but by their employment said water is compelled to

enter the passage or conduit 3, and the continued operation of the pan forcing water into said conduit causes the water to rise until it overflows into the trough 5, from whence it may be conveyed, if desired, to any other point for use.

The piston 17, is arranged in a compartment whose roof is formed by the partition 10, which prevents the passage of water up into the interior of the casing A, compelling the water to pass through the opening 2, into the passage or conduit 3.

Having thus described my invention, what I claim is—

In a rotary pump, the combination of a casing A, having inner walls 4 and outer walls 7, forming a water conduit 3, the walls 4 extending above the walls 7, the trough 5 arranged beneath the top of the walls 7, a rotatable shaft 24 supported vertically in said casing, a piston 17 carried by said rotatable shaft and having its lower edge formed into a series of inclined pushing or deflecting surfaces 17^a, a partition 10 located in said casing immediately above said piston, an intercepting plate 11 arranged beneath the piston and provided with inlet ports 2, a water inlet 1 formed in the outer wall 7 inlets 3 formed in the walls 4 opposite the periphery of the piston, and radially disposed cut-offs 31 arranged between the inlets 2, substantially as shown and described.

In testimony whereof I have hereunto subscribed my name in the presence of two witnesses.

STEPHEN N. EISLER.

Witnesses:

ROBT. E. RIES,
SIDNEY G. COOK.