

(19)



Europäisches Patentamt

European Patent Office

Office européen des brevets



(11)

EP 0 693 607 B1

(12)

EUROPEAN PATENT SPECIFICATION

(45) Date of publication and mention
of the grant of the patent:

24.03.1999 Bulletin 1999/12

(51) Int Cl.6: **E05D 11/10**

(21) Application number: **94810434.4**

(22) Date of filing: **21.07.1994**

(54) **Shutter which shifts vertically as a consequence of being rotated**

Laden, welcher infolge einer Schwenkung senkrecht verschoben wird

Volet qui se déplace verticalement par suite d'une rotation

(84) Designated Contracting States:
**AT BE CH DE DK ES FR GB GR IE IT LI LU MC NL
PT SE**

(43) Date of publication of application:
24.01.1996 Bulletin 1996/04

(73) Proprietor: **Coatbridge Limited
Douglas, Isle of Man (GB)**

(72) Inventor: **Ziegerlig, Max
CH-6598 Tenero (CH)**

(74) Representative: **Fiammenghi, Carlo et al
FIAMMENGHI-FIAMMENGHI,
Via San Gottardo 15
6900 Lugano (CH)**

(56) References cited:
EP-A- 0 386 342 GB-A- 1 404 765

EP 0 693 607 B1

Note: Within nine months from the publication of the mention of the grant of the European patent, any person may give notice to the European Patent Office of opposition to the European patent granted. Notice of opposition shall be filed in a written reasoned statement. It shall not be deemed to have been filed until the opposition fee has been paid. (Art. 99(1) European Patent Convention).

Description

[0001] The present invention is in the sphere of window and door frames, more specifically, the particular type of shutter or door that is suitable for separating rooms, such as shower compartments, which have liquids lying on the floor, so, when closed, they must exert a certain sealing pressure on elastic sealing elements which are placed in the floor at the point of contact with these to prevent these liquids from leaking out and spreading into the adjacent rooms.

[0002] The applicant considers that, in the current state of technology, no shutter exists that is in any way similar to the one to be described below. According to this invention, as in almost all cases, the shutter is supported by hinges formed by two members hinged with each other and placed one above the other, one resting on the other, with contact surfaces on the members themselves.

[0003] Currently it is very inconvenient to use such shutters in cases where, as mentioned, the intention is to exercise a sealing action on a seal below: the continual and repeated dragging of the lower part of the shutter on the elastic seals inevitably leads to their being worn and adversely affects their sealing capacity.

Furthermore, it is often rather difficult to open a shutter which has a seal exercising sealing pressure against it.

[0004] The aim of the inventor of the present idea has been to provide a shower compartment comprising a revolving shutter which lifts vertically to a sufficient extent to eliminate contact, and consequently wear, with the seal below, as soon as it begins to rotate, thus considerably prolonging the life of the seal and making it easier to open and close the shutter.

[0005] Patent EP-A-386 342 discloses a shutter whereby the lower hinge has a shape similar to that of the present invention, but that is aimed to solve a different problem, i.e. blocking the shutter at a wished position by lowering it at the end of its rotation, whereas the purpose of the present application is to disclose a hinge that causes a prefixed vertical lifting of the shutter during its rotation sufficient to eliminate contact with the seal below.

[0006] For this purpose the inventor has developed a shower compartment provided with a shutter which is fitted with a new type of hinge, which enables the shutter to lift as soon as the opening rotating begins, and to then reposition itself, exercising the desired pressure on the seal below, when its returning rotation is completed and it is closed.

[0007] The object of the invention is in fact a shower compartment as defined by the preamble of appended claim 1 characterized by the characterizing portion of this latter.

[0008] The advantages offered by the invention and a more detailed illustration of this will be clearer from the description which follows, in which reference will also be made to the enclosed drawing, which show:

in Fig. 1: the enlarged exploded perspective view of a hinge on a shutter, with the invention executed in the preferred manner;

in Fig. 2: the enlarged exploded perspective view of another type of hinge which may also be fitted with a shutter in accordance with the invention;

in Fig. 3: the perspective view of a shower box fitted with two shutters in accordance with the invention, of which one, slightly open, is raised;

in Fig. 4: the plan view of the shower box in Fig. 3.

[0009] It must first be pointed out that the shutters, is a shower compartment as in the invention, depending on their weight and the dimensions of the hinges, may be fitted with a single hinge or, in the most common case, with two or more hinges, with two of which positioned at the two extremities, upper and lower, as in fact usually occurs already with the revolving shutters and doors in use today.

[0010] In the execution in the preferred manner which will be described, the most typical case with two hinges is shown. Of these one (2) at least (see Fig. 1) has the characteristics making it possible to obtain the result already mentioned before, that is, to make shutter 1 lift vertically to a preset degree (see arrow A Figs. 1 and 3), as it revolves (see arrow B, Figures 1 and 4), moving away from seal 9.

[0011] This is obtained through the special shape given to the two members, 3 and 4, which comprise hinge 2, or rather, to their respective supporting surfaces 3a and 4a, which are in contact with each other. Of these, the supporting surface 4a of the lower member 4 has one or more appropriately shaped concave parts 4b (two in the example shown), while the supporting surface 3a of upper member 3 has the same number (one is not visible in the drawing) of shaped protruding parts 3b which substantially match those of 4b, and these concave 4b and protruding 3b parts are positioned in such a way that, with shutter 1 in closed position, each protruding part 3b is contained in one of the concave parts 4b.

[0012] It does not make any difference to the operation whether the concave parts are in the lower member (as shown) or on the upper member, and consequently the same obviously applies to the protruding parts.

[0013] By shaping said parts appropriately, for example, as shown in Fig. 1, in which the protruding parts 3b have a more or less semicircular "cam-shaped" profile and the concave parts 4b have a trapezoidal profile, and by appropriately connecting the various sections of the profile, a result is obtained in which, by rotating shutter 1 supported by a hinge 2 of this type, the cam-shaped protruding part 3b is raised along one of the sloping sides of the trapezoidal section of the concave part 4b coupled with it, thus sliding the shutter upwards (arrow A) to an extent equal to the "raise height", that is, to

height "h" of the protruding parts 3b.

[0014] As can be appreciated from the drawings, even a very limited angle of rotation of upper member 3 can raise shutter 1 sufficiently to release it from seal 9 below.

[0015] Once the lifting phase is completed, the protruding parts 3b then run on the remaining flat part of the supporting surface 4a of the lower member 4 without varying the position of shutter 1 vertically as the rotation continues. A particularly favourable ratio between the measurement of vertical lift of the shutter and the angle of rotation of this is 0.1 mm per 4° of rotation approximately, with a maximum lift of 0.7 mm per 30° of rotation approximately, but other scalings are possible without any particular repercussions on operating.

[0016] The example is shown in the drawings of an execution in the preferred manner in which, to allow an easier working of the parts and to permit easy replacement, the two aforementioned supporting surfaces 3a and 4a, rather than being directly or respectively on the two members 3 and 4 comprising hinge 2, are on two special organs 3' and 4', which are then fixed onto members 3 and 4; but it is clear that both the concave parts 4b and the protruding parts 3b can also be realized directly on the aforementioned members if there is some convenient reason for doing so.

[0017] Obviously, by rotating shutter 1 in the opposite closing direction, the protruding parts 3b will follow the same path in reverse and will fit again into the corresponding concave parts 4b of lower member 4 with shutter 1 closed. And it can also be immediately grasped that the closing or opening movement of the shutter may be carried out by making it revolve, depending on requirements and on its position, in either of the two directions of rotation, as the shutter itself, during the course of a 180° rotation, makes two distinct lifting and repositioning runs in geometrically specular positions.

[0018] The materials preferred for making the hinges, for instance in the case plastic or glass shutters for a shower box, are aluminium for the upper and lower members proper, and one of the numerous self-lubricating synthetic materials for the organs 3' and 4' of which the surfaces have the concave parts 4b and protruding parts 3b.

[0019] For the second hinge 6, which is usually situated at the highest part of shutter 1, the inventor proposes using a variety (Fig. 2) in which both the hinge pin 11 and other parts 12 have shapes and lengths suitable to enable member 8 joined to shutter 1 to shift vertically to an extent equal to the height "h" of maximum vertical lift of the shutter itself during the course of its rotation.

[0020] We do not deem it necessary to provide further details, as this type of hinge, the functioning of which in itself is known, will immediately be understood by a technician working in the field by simply observing Fig. 2.

[0021] The representation in the drawings and the description so far have only illustrated an execution in the preferred manner in the field of shutters for shower box-

es, but it is clear that different realizations of the shutter shown in the invention, for other uses too, are possible without going outside the scope of protection conferred by the enclosed claims, with respect to which the above execution in the preferred manner is neither limiting nor binding.

Claims

1. Shower compartment wherein a rotating shutter (1) is supported by at least one hinge (2) comprising two members (3, 4) which are hinged with each other and positioned one above the other, of which the lower one (4) is joined to a fixed structure (5) and the upper one (3), which rests upon this, is joined to the shutter (1) in rotation and the supporting surfaces (3a, 3b) of the two aforementioned members (3, 4), which are in contact with each other, have one or more concave parts (4b) respectively and the same amount of protruding parts (3b) which are substantially complementary to each other, the protruding parts (3b) of a member (3) being contained by the concave parts (4b) of the other member (4) when the shutter (1) is in closed position, wherein the height (h) of said protruding parts (3b) and concave parts (4b) is such that a relative rotation between the two aforementioned members (3, 4) causes a vertical shifting of the shutter (1), characterized in that the sealing between the lower part of the shutter and the compartment is accomplished by a flat seal atop a flat face of the compartment onto which seal the lower shutter edge exerts by weight a sealing pressure when closed.
2. Shower compartment in accordance with claim 1, wherein the rotating shutter is also fitted with one or more hinges (6) in which the two upper (7) and lower (8) members comprising the hinge are capable of shifting lengthwise during the rotation of the shutter (1) to an extent at least equal to the lift height (h) of the shutter (1) due to said protruding part(s) (3b) of the other hinges (2) connected to the shutter (1) itself.
3. Shower compartment in accordance with either of the previous claims, in which said supporting surfaces (3a, 4a) of the two aforementioned members (3, 4) in contact with each other, which have the aforementioned concave (4b) and protruding (3b) parts which are complementary to each other, are on two organs (3', 4') fixed to one of the two members (3, 4) respectively.
4. Shower compartment in accordance with claim 3, in which the two members (3, 4) comprising a hinge (2) are made of aluminium, and said organs (3', 4') are made of a self-lubricating synthetic material.

Patentansprüche

1. Duschkabine, bei welcher ein schwenkbarer Schließladen (1) durch mindestens ein Scharnier (2) gelagert ist, das zwei miteinander gelenkig verbundene sowie eines über dem anderen angeordnete Bauteile (3, 4) umfaßt, von denen das untere (4) mit einem ortsfesten Konstruktionselement (5) und das auf diesem ruhende obere (3) mit dem schwenkbaren Schließladen (1) verbunden ist, wobei die tragenden Flächen (3a, 4a) der zwei vorgenannten Bauteile (3, 4), welche miteinander in Berührung sind, jeweils ein Konkavteil oder mehrere Konkavteile (4b) und dieselbe Anzahl an vorragenden Teilen (3b), die im wesentlichen zueinander komplementär sind, besitzen, die vorragenden Teile (3b) des einen Bauteils (3) von den Konkavteilen (4b) des anderen Bauteils (4) aufgenommen werden, sobald sich der Schließladen (1) in der Schließposition befindet, und die Höhe (h) der vorragenden Teile (3b) sowie der Konkavteile (4b) derart ist, daß eine Relativedrehung zwischen den zwei vorgenannten Bauteilen (3, 4) eine vertikale Verschiebung des Schließladens (1) bewirkt, dadurch gekennzeichnet, daß die Abdichtung zwischen dem unteren Teil des Schließladens und der Kabine durch eine flache Dichtung oben auf einer ebenen Fläche der Kabine bewerkstelligt wird, auf welche Dichtung die untere Schließladenkante einen Abdichtdruck durch Masse zur Zeit des Schließens ausübt.
2. Duschkabine nach Anspruch 1, dadurch gekennzeichnet, daß der schwenkbare Schließladen ferner mit einem Scharnier oder mehreren Scharnieren (6) ausgestattet ist, von denen die zwei oberen (7) und unteren (8), das Scharnier bildenden Konstruktionsteile imstande sind, sich während einer Drehbewegung des Schließladens (1) in einem Ausmaß in Längsrichtung zu verschieben, das aufgrund des/der vorragenden Teils/Teile (3b) der anderen, mit dem Schließladen (1) selbst verbundenen Scharniere (2) mindestens der Hubhöhe (h) des Schließladens (1) gleich ist.
3. Duschkabine nach einem der vorherigen Ansprüche, dadurch gekennzeichnet, daß die erwähnten tragenden Flächen (3a, 4a) der zwei vorgenannten, miteinander in Berührung befindlichen Bauteile (3, 4), welche die vorerwähnten, zueinander komplementären konkaven (4b) und vorragenden Teile (3b) aufweisen, an zwei Bauelementen (3', 4') vorhanden sind, die jeweils an einem der zwei Bauteile (3, 4) befestigt sind.
4. Duschkabine nach Anspruch 3, dadurch gekennzeichnet, daß die zwei Bauteile (3, 4), die ein Scharnier (2) bilden, aus Aluminium gefertigt und die ge-

nannten Bauelemente (3', 4') aus einem selbstschmierenden synthetischen Material hergestellt sind.

Revendications

1. Compartiment de douche dans lequel un volet tournant (1) est supporté par au moins un gond (2) comprenant deux éléments (3,4) qui sont articulés ensemble et placés l'un au-dessus de l'autre, dont celui disposé le plus bas (4) et lié à une structure fixe (5) et celui le plus haut (3), qui repose sur celui-ci, est lié au volet (1) en rotation, et les surfaces de support (3a, 3b) des deux éléments mentionnés ci-dessus (3,4), qui sont en contact l'une avec l'autre, ont une ou plusieurs parties concaves (4b) respectivement et la même quantité de parties saillantes (3b) qui sont sensiblement complémentaires les unes des autres, les parties saillantes (3b) d'un élément (3) étant contenues dans les parties concaves (4b) de l'autre élément (4) quand le volet (1) est en position fermée, dans lequel la hauteur (h) des dites parties saillantes (3b) et des parties concaves (4b) est telle qu'une rotation relative entre les deux éléments mentionnés ci-dessus (3,4) provoque un déplacement vertical du volet (1), caractérisé en ce que l'étanchéité entre la partie inférieure du volet et le compartiment est accomplie par un joint plat placé sur une face plate du compartiment, le bord inférieur du volet exerçant par son poids une pression d'étanchéité sur ledit joint en position fermée.
2. Compartiment de douche selon la revendication 1, dans lequel le volet tournant est aussi équipé d'un ou plusieurs gonds (6) dans lesquels les deux éléments inférieurs (7) et supérieurs (8) constituant le gond sont capables de se déplacer en direction de la longueur pendant la rotation du volet (1) d'une quantité au moins égale à la hauteur de soulèvement (h) du volet (1) due aux dites parties saillantes (3b) des autres gonds (2) reliés au volet (1) lui-même.
3. Compartiment de douche selon l'une quelconque des revendications précédentes, dans lequel les dites surfaces de support (3a, 4a) des deux éléments (3,4) mentionnés ci-dessus en contact l'un avec l'autre, qui comportent les parties concaves (4b) et saillantes (3b) mentionnées ci-dessus qui sont complémentaires les unes des autres, sont sur deux organes (3', 4') fixés à l'un des deux éléments (3,4) respectivement.
4. Compartiment de douche selon la revendication 3, dans lequel les deux éléments (3,4) constituant un gond (2) sont en aluminium, et lesdits organes (3', 4') sont en un matériau synthétique auto-lubrifiant.

FIG. 2

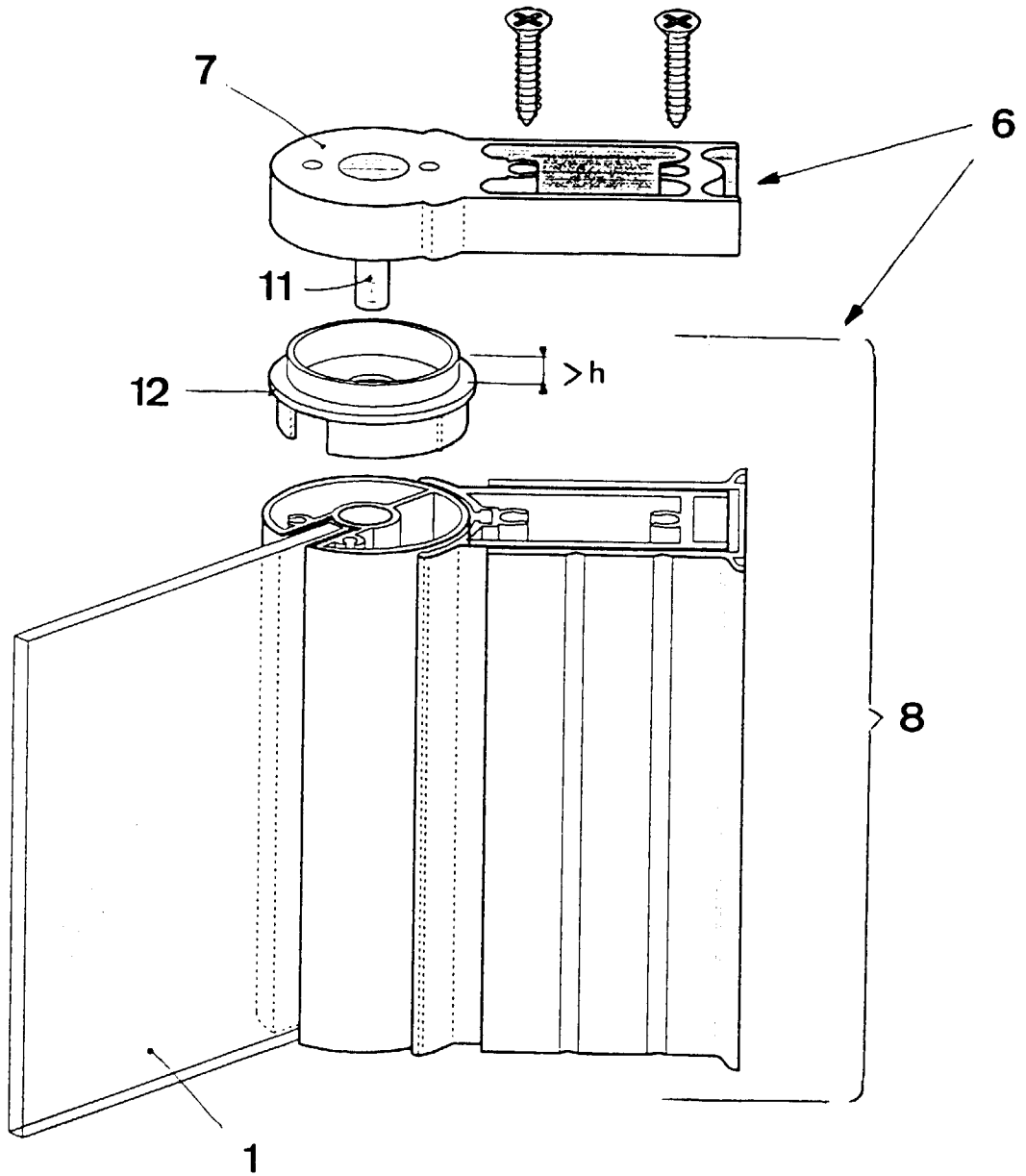

FIG. 3

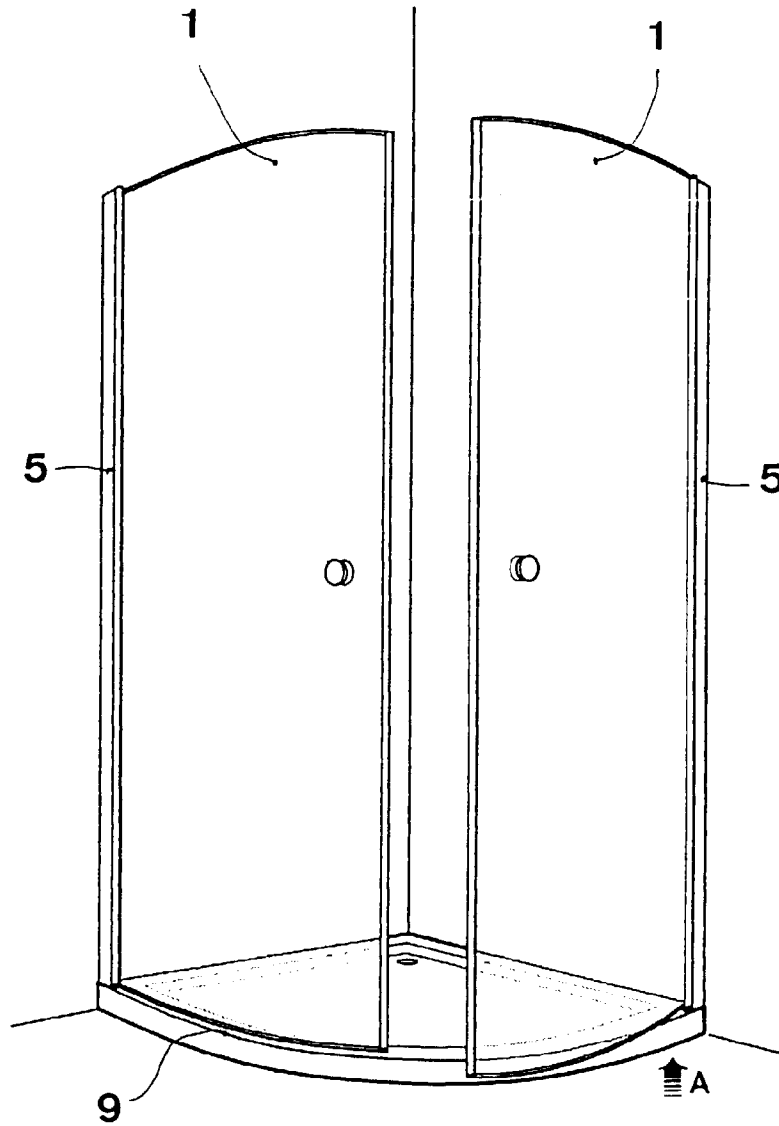

FIG. 4

