

(19) World Intellectual Property Organization  
International Bureau



(43) International Publication Date  
22 November 2001 (22.11.2001)

PCT

(10) International Publication Number  
**WO 01/87398 A2**

(51) International Patent Classification<sup>7</sup>: **A61M 25/00**

(21) International Application Number: PCT/US01/11260

(22) International Filing Date: 9 April 2001 (09.04.2001)

(25) Filing Language: English

(26) Publication Language: English

(30) Priority Data:  
09/573,035 17 May 2000 (17.05.2000) US

(71) Applicant: **SCIMED LIFE SYSTEMS, INC.** [US/US];  
One SciMed Place, Maple Grove, MN 55133-1566 (US).

(72) Inventors: **CARRILLO, Oscar, R., Jr.**; 393 Tiffany Street, Attleboro, MA 02703 (US). **HOLMES, John**; 12 Lakeview Circle, Chepachete, RI 02814 (US). **RICHARDSON, Kevin**; 19 Breakneck Hill Road, Hopkinton, MA 01748 (US).

(74) Agents: **ATKINSON, Robert, E.** et al.; Crompton, Seager & Tufte, LLC, Suite 895, 331 Second Avenue south, Minneapolis, MN 55401-2246 (US).

(81) Designated States (*national*): AE, AG, AL, AM, AT, AU, AZ, BA, BB, BG, BR, BY, BZ, CA, CH, CN, CR, CU, CZ, DE, DK, DM, DZ, EE, ES, FI, GB, GD, GE, GH, GM, HR, HU, ID, IL, IN, IS, JP, KE, KG, KP, KR, KZ, LC, LK, LR, LS, LT, LU, LV, MA, MD, MG, MK, MN, MW, MX, MZ, NO, NZ, PL, PT, RO, RU, SD, SE, SG, SI, SK, SL, TJ, TM, TR, TT, TZ, UA, UG, UZ, VN, YU, ZA, ZW.

(84) Designated States (*regional*): ARIPO patent (GH, GM, KE, LS, MW, MZ, SD, SL, SZ, TZ, UG, ZW), Eurasian patent (AM, AZ, BY, KG, KZ, MD, RU, TJ, TM), European patent (AT, BE, CH, CY, DE, DK, ES, FI, FR, GB, GR, IE, IT, LU, MC, NL, PT, SE, TR), OAPI patent (BF, BJ, CF, CG, CI, CM, GA, GN, GW, ML, MR, NE, SN, TD, TG).

**Published:**  
— *without international search report and to be republished upon receipt of that report*

*For two-letter codes and other abbreviations, refer to the "Guidance Notes on Codes and Abbreviations" appearing at the beginning of each regular issue of the PCT Gazette.*



**WO 01/87398 A2** (54) Title: FLUID SEAL FOR ENDOSCOPE

(57) **Abstract:** An endoscope seal that effectively inhibits the egress of fluids from the working channel of an endoscope when an elongate device having a non-circular shaft is disposed therein. The endoscope seal includes a body portion having a proximal end adapted for insertion of an elongate device such as a rapid exchange biliary catheter, a distal end adapted for connection to the proximal end of an endoscope, a lumen extending therethrough which is adapted to receive the elongate device and to provide access to the working channel of the endoscope, and a means for conforming to the non-circular shaft of the elongate device to inhibit the flow of fluid from the working channel of the endoscope. The conforming means may, for example, comprise one or more protrusions extending radially inward in the lumen of the body portion, a sealing material such as a surgical foam that is disposed in the lumen of the body portion, or a sealing mandrel. Whether a single protrusion, a plurality of protrusions, a sealing material or a sealing mandrel is utilized, the present invention provides endoscope seals that readily seal about elongate devices having either circular or non-circular profiles.

## FLUID SEAL FOR ENDOSCOPE

### Field of the Invention

The present invention general relates to endoscopic systems and procedures. More specifically, the present invention relates to seals for use in combination with an endoscope, sometimes referred to as endoscope seals or biopsy seals.

### Background of the Invention

Endoscopic procedures for treating abnormal pathologies within the alimentary canal system and biliary tree (including the biliary, hepatic, and pancreatic ducts) are increasing in number. The endoscope provides access to the general area of a desired duct using direct visualization. However, the duct itself must be navigated using a catheter in conjunction with a guidewire under fluoroscopy. A wide variety of catheters are known for treatment of such targeted anatomical regions. Examples of biliary catheters are disclosed in U.S. Patent Number 5,397,302 to Weaver et al., U.S. Patent Number 5,320,602 to Karpziel and U.S. Patent Number 5,921,971 to Argo et al., the disclosures of which are hereby incorporated by reference.

Argo et al. '971 discloses a catheter for use in biliary procedures, wherein the catheter includes a shaft having a proximal end and a distal end. A guidewire lumen extends through the shaft from a proximal guidewire port located proximal of the distal end of the shaft, to a distal guidewire port located at the distal end of the shaft. The shaft may also include a slot or channel extending from a proximal end of the shaft to the proximal guidewire port. By utilizing a slot or channel, the proximal shaft portion has a non-circular profile or cross-section as best seen in Figures 5A and 6A of Argo et al. '971. Catheters incorporating such a guidewire opening and channel are often referred to as rapid exchange or single operator exchange type biliary catheters. One drawback with such rapid exchange or single operator exchange biliary catheters is the inability or relative difficulty in sealing around the non-circular shaft, such that fluid (bile liquid and air) may leak out of the working channel of the endoscope around the non-circular shaft of the biliary catheter.

Conventional endoscope seals are adapted to seal about catheters having circular shafts, and generally do not effectively seal about catheters having non-circular shafts. Such conventional seals are commercially available from Olympus, Fuji and Pentax. An example of a prior art endoscope seal is disclosed in U.S. Patent Number 4,920,953 to McGown. The endoscope seals commercially available and the

endoscope seal disclosed in McGown '953 generally include a body portion having a proximal end adapted to receive an elongate device such as a biliary catheter, a distal end adapted for connection to the proximal end of the endoscope, a lumen extending through the body portion, and a membrane disposed in the lumen, wherein the  
5 membrane includes a small circular hole or aperture. The circular aperture is sized to closely fit the elongate device inserted therein such that fluids (bile and air) do not readily escape from the working channel of the endoscope.

However, it can be readily appreciated that when a biliary catheter or other elongate device having a shaft with a non-circular cross section is placed through the  
10 circular aperture, at least a portion of the aperture does not engage the non-circular shaft. Accordingly, such prior art endoscope seals do not effectively inhibit the egress of bile liquids and air exiting the working channel of the endoscope when an elongate device having a non-circular cross-section is utilized. Because rapid exchange catheters are becoming more prevalent, and because such rapid exchange catheters  
15 have a non-circular shaft cross-section, there is a significant demand for an endoscope seal that effectively seals or inhibits the egress of fluid from the working channel of an endoscope, when a device having a non-circular shaft cross-section is used therewith.

#### Summary of the Invention

20 The present invention satisfies this demand by providing an endoscope seal that effectively inhibits the egress of fluid from the working channel of an endoscope when an elongate device, such as a rapid exchange biliary catheter, having a non-circular shaft is disposed therein. The seal of the present invention is also suitable for other catheters having non-circular shafts such as rapid exchange vascular catheters.  
25 In addition, some embodiments of the present invention are perfectly suitable for sealing about elongate devices having shafts with a circular profile. Accordingly, the endoscope seals of the present invention are both versatile and functional, because they effectively inhibit, or at least reduce, the egress of fluids (bile and air) from the working channel of the endoscope when an elongate device having a circular or non-  
30 circular shaft is utilized.

The endoscope seals of the present invention include a body portion having a proximal end adapted for insertion of an elongate device such as a rapid exchange type catheter, a distal end adapted for connection to the proximal end of an

endoscope, a lumen extending therethrough which is adapted to receive the elongate device and to provide access to the working channel of the endoscope, and a means for conforming to the non-circular shaft of the elongate device to inhibit the flow of fluid from the working channel of the endoscope.

5           In a first embodiment, the conforming means may comprise a protrusion extending radially inward in the lumen of the body portion. The protrusion may comprise a geometry that mates with the non-circular shaft of the elongate device. In a second embodiment, the conforming means may comprise a plurality of protrusions extending radially inward in the lumen body portion. The plurality of protrusions  
10 may be uniformly spaced about the circumference of the lumen and may have sufficient flexibility to conform to a non-circular geometry. In a third embodiment, the conforming means may comprise a sealing material such as a surgical foam that is disposed in the lumen of the body portion or injected therein just prior to use. In a fourth embodiment, the conforming means may comprise a sealing mandrel that it is  
15 disposed in the lumen of the body portion. The sealing mandrel conforms to the non-circular geometry to define a collective circular geometry that is readily sealed by a conventional circular aperture in the body portion. Whether a single protrusion, a plurality of protrusions, a sealing material or a sealing mandrel, the present invention provides endoscope seals that readily seal about an elongate devices having either  
20 circular or non-circular profiles.

The present invention also provides a variable diameter main body portion and a compression mechanism. The variable diameter main body portion may incorporate a conventional membrane with a circular aperture or may incorporate any of the conforming means described above. The compression mechanism may be used to  
25 tighten the variable diameter body portion to compress the membrane therein around a non-circular shaft to establish a fluid seal.

#### Brief Description of the Drawings

Figure 1A is a side view of the endoscope seal of the present invention;

Figure 1B is a top view of the endoscope seal shown in Figure 1A;

30           Figure 2A is a top view of a body portion of an endoscope seal utilizing a plurality of protrusions;

Figure 2B is a cross-sectional view taken along line 2B-2B in Figure 2A;

Figure 3A is a top view of a body portion of an endoscope seal utilizing a single protrusion;

Figure 3B is a cross-sectional view taken along line 3B-3B in Figure 3A;

Figure 4A is top view of a body portion of an endoscope seal utilizing a sealing material;

Figure 4B is a cross-sectional view taken along line 4B-4B in Figure 4A;

Figure 5A is a top view of a body portion of an endoscope seal utilizing an injected sealing material;

Figure 5B is a cross-sectional view taken along line 5B-5B in Figure 5A (Figure 5B also illustrates an injection apparatus);

Figure 6A is an isometric view of a tightening ratchet for use in combination with a variable diameter valve;

Figure 6B is a top view of the tightening ratchet illustrated in Figure 6A;

Figure 6C is an isometric view of the tightening ratchet illustrated in Figure 6A disposed about a variable diameter main body portion;

Figure 6D is a cross-sectional view of the tightening ratchet disclosed about the variable diameter main body portion as illustrated in Figure 6C;

Figure 7A is a top view of a body portion of an endoscope seal utilizing a sealing mandrel;

Figure 7B is a cross-sectional view taken along line 7B-7B in Figure 7A; and

Figure 7C is a cross-sectional view of the sealing mandrel illustrated in Figures 7A and 7B.

#### Detailed Description of the Preferred Embodiments

The following detailed description should be read with reference to the drawings in which similar elements and different drawings are numbered the same. The drawings, which are not necessarily to scale, depict illustrative embodiments and are not intended to limit the scope of the invention.

Refer now to Figure 1A which illustrates a side view of an endoscope seal in accordance with the present invention. Endoscope seal 10 includes a main body portion 100, a plus portion 20 and an adapter ring portion 30. The details of main body portion 100 are discussed in more detail with reference to Figures 2A and 2B. Main body portions 200, 300, 400, and 500 as discussed in detail with reference

Figures 3A-3B, Figures 4A-4B, Figures 5A-5B, and Figure 6D, respectively, may be used in place of main body portion 100.

Main body portion 100 includes a body 112 having a proximal end and a distal end. An outwardly extending flange 114 is connected to the distal end of the body 112. An inwardly extending flange 116 is connected to the proximal end of the body 112. As best seen in Figure 1B, a central lumen 120 extends through body 112, and a seal 140 is disposed in the lumen 120. Central lumen 120 is sized to accommodate the shaft of elongate device such as a biliary catheter (not shown).

The plug portion 20 is connected to the main body portion 100 by a flexible arm 22. The plug portion 20 includes a cap 24, a middle portion 26, and a flange 28. The flexible arm 22 allows the plug portion 20 to be inserted into the proximal end of the main body portion 100 and seal the central lumen 120 in the absence of any devices inserted therein.

The adapter ring portion 30 is connected to the main body portion 100 by a flexible arm 32. The adapter ring portion 30 includes an inwardly extending top flange 36 and an inwardly extending bottom flange 38 which together define a recess 37 within the ring 30. Adapter ring portion 30 also defines a central lumen 34. The flexible arm 32 permits the adapter ring portion 30 to be placed around the flange 114 of the main body portion 100. The adapter ring portion 30 permits the endoscope seal 10 to be connected to an endoscope having a larger diameter proximal end as will be discussed in more detail hereinafter.

Refer now to Figures 2A and 2B which illustrate the features of main body portion 100 in greater detail. Central lumen 120 includes a proximal port 121, an upper cavity 122, a middle cavity 124, a lower cavity 126, and a distal port 127. The proximal port 121 has an inside diameter slightly less than the outside diameter of the flange 28 of the plug portion 20. The upper cavity 122 is sized to accommodate the flange 28 of the plug portion 20. With this arrangement, the flange 28 may be snapped through the proximal port 121 into the upper cavity 122 such that the plug portion 20 effectively seals the central lumen 120 when no devices are present therein.

Distal port 127 is sized to be slightly smaller than the diameter of the proximal end of the endoscope. The lower cavity 126 is sized to accommodate the flange of the proximal end of the endoscope (not shown). Within the arrangement, the proximal end of the endoscope may be snapped into the distal port 127 to connect the

endoscope seal 10 to the endoscope and to establish fluid communication between the central lumen 120 and the working channel of the endoscope.

If the proximal end of the endoscope is too large for the lower cavity 126 and distal port 127, the adapter ring portion 30 may be placed on the flange 114. Specifically, the lumen 34 of the adapter ring portion 30 has a diameter that is slightly less than the outside diameter of the flange 114. The recess 37 between the upper flange 36 and lower flange 38 of the adapter ring portion 30 is sized to accommodate the flange 114 leaving sufficient space to accommodate the proximal flange of the endoscope. With this arrangement, the adapter ring portion 30 may be snapped into place around the flange 114 and the proximal flange of the endoscope (not shown) may be snapped into the recess 37 of the adapter ring portion 30. Thus, the adapter ring portion 30 in combination with the flange 114 permits the endoscope seal 10 to fit endoscopes of different sizes.

With this arrangement, the distal end of the main body portion 100 may be connected to the proximal end of the endoscope (not shown). When the main body portion 100 is connected to the endoscope, the central lumen 120 is aligned with and in fluid communication with the working channel of the endoscope. The central lumen 120 is sized and adapted for insertion of an elongate device such as a biliary catheter. Thus, an elongate device may be inserted into the proximal end of the main body portion 100, through the lumen 120, and into the working channel of the endoscope.

The middle cavity 124 of the central lumen 120 is defined by the seal mechanism 140. Middle cavity 124 is conically shaped to facilitate easy insertion of an elongate device therein. The conically shaped cavity 124 tapers from a proximal aperture 142 to a distal aperture 144. A plurality of inwardly projecting protrusions 146 extend from the proximal aperture 142 to the distal aperture 144. Although eight protrusions 146 are illustrated, it is contemplated that virtually any number of protrusions 146 may be utilized. Protrusion 146 is uniformly spaced about the wall 148 defining the lumen 124. The protrusions 146 are sufficiently flexible to conform to a non-circular shaft of an elongate device inserted therein.

For example, if the non-circular shaft illustrated in Figures 5A and 6A of Argo et al. '971 was inserted into the seal mechanism 140, one or more of the protrusions 146 would be disposed in the non-circular portion (i.e., the C-shaped channel) of the

shaft, thereby effectively sealing about the non-circular shaft. Although the protrusions 146 may not provide a fluid-tight seal about a non-circular shaft, it is believed that any decrease in the amount of fluid (bile and air) escaping from the working channel of the endoscope is a significant improvement. Accordingly, as used  
5 herein, the term seal may refer to a fluid-tight seal or a seal which significantly inhibits the egress of fluid. The entire endoscope seal 10 may be made of conventional materials using conventional techniques. For example, the endoscope seal 10 may be formed by injection molding a flexible medical grade silicone. From the functional description provided herein, those skilled in the art will readily  
10 appreciate that the endoscope seal 10 may be formed from a wide variety of suitable flexible materials such as rubber, silicon or elastomer. In addition, the endoscope seal 10 may be made by a variety of different manufacturing methods, but injection molding is preferred.

The endoscope seal 10 may have an overall length on the order of 3.670  
15 inches. The flexible arms 22 and 32 may have a thickness on the order of 0.085 inches and a width on the order of 0.20 inches. The plug portion 20 may have a thickness of approximately 0.255 inches and an outside diameter of approximately 0.560 inches. The flange 28 of the plug 20 may have an outside diameter of approximately 0.400 inches and a thickness of approximately 0.085 inches. The  
20 middle portion 26 of the plug 20 may have a diameter of approximately 0.320 inches and a thickness of approximately 0.085 inches.

The adapter ring portion 30 may have an outside diameter portion of approximately 0.780 inches, an inside diameter of approximately 0.500 inches, and a thickness of approximately 0.260 inches. The top flange 36 and the bottom flange 38  
25 of the adaptor ring portion 30 may have a thickness of approximately 0.065 inches, and the recess 37 may be approximately 0.040 inches deep.

The main body portion 100 may have an overall height of approximately 0.550 inches. The body 112 may have a diameter of approximately 0.560 inches and a height of approximately 0.480 inches. The flange 114 may have an outside diameter  
30 of approximately 0.680 inches and a thickness of approximately 0.70 inches. The proximal port 121 may have an inside diameter tapering from approximately 0.400 inches to an approximately 0.320 inches. Similarly, the distal port 127 may have an inside diameter tapering from approximately 0.280 inches to approximately 0.200



inches. The upper cavity 122 may have a diameter of 0.400 inches and a height of approximately 0.110 inches. The lower cavity 126 may have a diameter of approximately 0.350 inches and a height of approximately 0.130 inches. The middle cavity 124 may have an inside diameter tapering from approximately 0.170 inches to approximately 0.040 inches. The individual protrusions 146 may be tapered from the proximal aperture 142 to the distal aperture 144, having a width of approximately 0.020 inches tapering to approximately 0.015 inches. The protrusions 146 may be separated by slots, each having a width tapering from approximately 0.023 inches to approximately 0.003 inches.

Those skilled in the art will recognize that the endoscope seal 10 may have dimensions different than the above dimensions, which are provided for purposes of illustration only.

Refer now Figures 3A and 3B which illustrate body portion 200 in accordance with an alternative embodiment of the present invention. As mentioned previously, body portion 200 may be used in place of body portion 100 as described with reference to Figures 1A, 1B, 2A, and 2B. Except as described hereinafter and except as shown in the drawings, body portion 200 is the same in design and function as body portion 100.

Main body portion 200 includes a seal mechanism 240. Seal mechanism 240 includes a single protrusion 246 extending radially inward. Protrusion 246 extends from a proximal aperture 242 to a distal aperture 244. Protrusion 246 may have a wide variety of geometries, but preferably has a geometry that mates with the non-circular portion of the shaft of the elongate device inserted into the central lumen 120. For example, if the non-circular shaft illustrated in Figures 5A and 6A of Argo et al '971 were disposed in the central lumen 120, the single protrusion 246 would preferably have a geometry conforming to the slot of the C-shaped channel. Those skilled in the art will recognize that other non-circular shafts may be utilized and that the protrusion 246 may be modified to mate with the non-circular portion thereof.

Because the single protrusions 246 will limit rotation of the elongate device inserted through the central lumen 120, it may desirable to permit rotation of the main body portion 200. This may be accomplished, for example, by providing a low-friction connection between the distal end of the main body portion 200 and the

proximal end of the endoscope. A low-friction connection may be accomplished by a variety of means, such as by utilizing low-friction materials and lubricants.

Refer now to Figures 4A and 4B which illustrate main body portion 300 in accordance with yet another embodiment of the present invention. As mentioned previously, main body portion 300 may be used in place of main body portion 100 described with reference to Figures 1A, 1B, 2A, and 2B. Except as described hereinafter and except illustrated in the drawings, main body portion 300 is the same in design and function as main body portion 100. In this particular embodiment, main body portion 300 utilizes includes a seal 140 comprising a material having characteristics of easy penetration high-fluid absorption, and tear resistance, such as a surgical foam to seal about the non-circular shaft. Sealing material 340 is disposed in the upper cavity 122, and to accommodate the sealing material 340, the height of the upper cavity 122 is increased at the expense of the height of the middle cavity 124. Although not shown, a liquid drainage line and reservoir may be connected to the upper cavity 122 to drain excess fluid (bile and air) therefrom.

The sealing material 340 may comprise virtually any suitable medical grade material that has easy penetration, high-fluid absorption, and tear resistance characteristics. Preferably, the sealing material comprises a closed-cell medium density surgical foam commercially available from Rynel of Maine. When a non-circular shaft of an elongate device is inserted through the sealing material 340, the sealing material 340 tends to create a passage conforming to the profile of the non-circular shaft, thereby effective sealing about the non-circular shaft.

The sealing material 340 may be relatively liquid or relatively solid. For example, the sealing material 340 may be relatively solid such that it is suitable for molding into a wide variety of desired shapes. The sealing material 340 may be molded to fit in the upper cavity 122 and to have a pilot hole extending therethrough. Whether the sealing material 340 is in the form of a liquid or solid, the plug portion 20 may be utilized to keep the sealing material 340 contained in the upper cavity 122 prior to use.

The sealing material may alternatively comprise fibrous materials that are very compliant and fluid absorbent such as cotton or synthetic fabrics. Alternatively, the sealing material 340 may comprise a gel-like material to develop a very lubricious and compliant seal. The sealing material 340 may be cold-molded or insert-molded

and a lubricant may be added to the sealing material to reduce friction and increase fluid absorption.

Refer now to Figures 5A and 5B, which illustrate main body portion 400 in accordance with yet another alternative embodiment of the present invention. Except as described hereinafter and except as illustrated in the drawings, main body portion 400 is the same in design and function as main body portion 300 described in reference to Figures 4A and 4B. Main body portion 400 includes an injectable sealing material 440 that may be injected into the upper cavity 122 just prior to use. To facilitate such injection, the body 112 may be provided with a thin-walled section 412. A suitable injection device such as a syringe 450 may be used to pierce the thin-walled portion 412 and inject the liquid sealing material 440. Sealing material 440 may be injected into the upper cavity 122 with the plug portion 20 inserted into the proximal end of the main body portion 400 to contain the sealing material 440 in the upper cavity 122 prior to use. Sealing material 440 has the same properties and performs the same function as sealing material 340 described with reference to Figures 4A and 4B, except sealing material 440 has a lower initial viscosity.

Refer now to Figures 6A, 6B, 6C, and 6D which illustrate a variable diameter main body portion 500 and tightening ratchet 600 for use therewith. Except as described herein and except as shown in the drawings, variable diameter body main portion 500 is the same in design and function as main body portion 100 described with reference to Figures 1A, 1B, 2A, and 2B. The body 512 includes a central waist portion 514 that facilitates compression of the lumen 124 at relatively low forces due to the reduced diameter of the waist 514. However, it is contemplated that the compressive forces of the tightening ratchet 600 may be used with or without the reduced diameter waist portion 514. In particular, the tightening ratchet 600 may be used with a constant diameter body 512. By actuating tightening ratchet 600 disposed about the variable diameter main body portion 500 as illustrated in Figures 6C and 6D, the central cavity 124 reduces in diameter and seals about the non-circular shaft of the elongate device extending therethrough.

Tightening ratchet 600 includes a hoop 610 that may vary in diameter by virtue of the sliding ends 612 and 614. Note that if a reduced diameter waist portion 514 is provided on the variable diameter main body portion 500, the hoop 610 may include a conforming geometry as illustrated in Figure 6D. Tightening ratchet 600

further includes a plurality of teeth 622 that engage a lever arm 630 to lock the moving ends 612 and 614 of the hoop 610 as the diameter of the hoop 610 is decreased. The teeth 622 are disposed on a flexible arm 620 that is normally biased against the lever arm 630 but may be deflected to permit the teeth 622 to disengage the lever arm 630, thereby permitting the ends 612 and 614 of the loop 610 to move and thereby increase the diameter of the hoop 610. Both the flexible arm 620 and the lever arm 630 may include gripping surfaces 624 and 632, respectively, to facilitate easy gripping of the tightening ratchet 600. Those skilled in the art will recognize that there are many alternative compression mechanisms to tightening ratchet 600, such as a screw-type compression clamp, a spring compression clamp, etc.

Refer now to Figures 7A, 7B and 7C which illustrate main body portion 700 in accordance with another embodiment of the present invention. Except as described herein and except as illustrated in the drawings, main body portion 700 is the same in design and function as main body portion 200 described with reference to Figures 3A and 3B. Main body portion 700 includes a seal mechanism 740. Seal mechanism 740 includes a sealing mandrel 746 extending through the central lumen 120. Sealing mandrel 746 may have a wide variety of cross-sectional geometries, but preferably has a geometry that mates with the non-circular portion of the shaft of the elongate device inserted into the central lumen 120. For example, if the non-circular shaft illustrated in Figure 5A and 6A or Argo et al. '971 were disclosed in the central lumen 120, the sealing mandrel 746 would preferably have a geometry conforming to the slot of this C-shaped channel, as best seen in Figure 7C. The entire length of the sealing mandrel 746 may have a conforming geometry or only the portion of the sealing mandrel 746 extending from the proximal aperture 742 to the distal aperture 744 may have a conforming geometry while the remainder of the sealing mandrel 746 has a different cross-sectional geometry, such as a circular cross-section. Those skilled in the art will recognize that other non-circular shafts may be utilized and that the sealing mandrel 746 may be modified to have a cross-sectional geometry that mates with the non-circular portion thereof. Thus, with the sealing mandrel 746 disposed in the slot of the biliary catheter (such as biliary catheter disclosed in Argo et al. '971), the collective cross-sectional profile is essentially circular such that the circular aperture 744 is able to establish a fluid tight seal.

Those skilled in the art will recognize that the present invention may be manifested in a variety of forms other than the specific embodiments described and contemplated herein. Accordingly, departures in form and detail may be made without departing from the scope and spirit of the present invention as described in

5 the appended claims.

What is claimed is:

1. A seal for use in combination with an elongate device and an endoscope, the elongate device having a shaft, the endoscope having a proximal end and a working channel extending therethrough, the seal comprising:

a body portion having a proximal end adapted for insertion of the elongate device, a distal end adapted for connection to the proximal end of the endoscope, and a wall defining a lumen extending therethrough adapted to receive the elongate device and to provide access to the working channel of the endoscope; and

at least one protrusion disposed in the lumen of the body portion, the protrusion extending radially inward from the wall to sealingly engage the shaft of the elongate device.

2. A seal as in claim 1, wherein a plurality of protrusions are utilized.

3. A seal as in claim 2, wherein the protrusions are uniformly spaced about the wall defining the lumen.

4. A seal as in claim 3, wherein the protrusions are sufficiently flexible to conform to a non-circular shaft.

5. A seal as in claim 4, wherein the non-circular shaft comprises a shaft of a rapid-exchange type catheter.

6. A seal as in claim 5, wherein the non-circular shaft includes a slot therein.

7. A seal as in claim 6, wherein the non-circular shaft includes a C-shaped channel therein.

8. A seal as in claim 4, further comprising;  
a plug adapted to seal the proximal end of the body portion; and  
a flexible arm extending from the body portion and connected to the plug.

9. A seal as in claim 8, further comprising;  
an adapter ring for connection to the distal end of the body portion; and  
a flexible arm extending from the body portion and connected to the adapter ring.
10. A seal for use in combination with an elongate device and an endoscope, the elongate device having a non-circular proximal shaft, the endoscope having a proximal end and a working channel extending therethrough, the seal comprising:  
a body portion having a proximal end adapted for insertion of the elongate device, a distal end adapted for connection to the proximal end of the endoscope, and a lumen extending therethrough adapted to receive the shaft of the elongate device and to provide access to the working channel of the endoscope; and  
a means for conforming to the non-circular shaft of the elongate device to inhibit the flow of fluid, the conforming means disposed in the lumen of the body portion.
11. A seal as in claim 10, wherein the conforming means comprises a protrusion extending radially inward in the lumen of the body portion.
12. A seal as in claim 11, wherein the protrusion comprises a geometry that mates with the non-circular shaft of the elongate device.
13. A seal as in claim 10, wherein the conforming means comprises a plurality of protrusions extending radially inward in the lumen of the body portion.
14. A seal as in claim 10, wherein the conforming means comprises a sealing material.
15. A seal as in claim 14, wherein the body portion includes a thin-walled portion for injection of the surgical foam.

16. A seal as in claim 13, further comprising;  
a plug adapted to seal the proximal end of the body portion; and  
a flexible arm extending from the body portion and connected to the plug.
17. A seal as in claim 16, further comprising;  
an adapter ring for connection to the distal end of the body portion; and  
a flexible arm extending from the body portion and connected to the  
adapter ring.
18. An endoscopic system comprising:  
an endoscope having a proximal end and a working channel extending  
therethrough;  
an elongate device having a non-circular proximal shaft disposed in the  
working channel of the endoscope; and  
a seal including a body portion having a proximal end, a distal end, a lumen  
extending therethrough, and a means, disposed in the lumen, for conforming to the  
non-circular shaft of the elongate device to inhibit the flow of fluid, wherein the distal  
end of the body is connected to the proximal end of the endoscope and the lumen  
receives the elongate device and provides access to the working channel of the  
endoscope.
19. An endoscopic system as in claim 18, wherein the conforming means  
comprises a protrusion extending radially inward in the lumen of the body portion.
20. An endoscopic system as in claim 19, wherein the protrusion  
comprises a geometry that mates with the non-circular shaft of the elongate device.
21. An endoscopic system as in claim 18, wherein the conforming means  
comprises a plurality of protrusions extending radially inward in the lumen of the  
body portion.
22. An endoscopic system as in claim 18, wherein the conforming means  
comprises a sealing material.



23. An endoscopic system as in claim 22, wherein the body portion includes a thin-walled portion for injection of the sealing material.

24. An endoscopic system as in claim 21, further comprising;  
a plug adapted to seal the proximal end of the body portion; and  
a flexible arm extending from the body portion and connected to the plug.

25. An endoscopic system as in claim 24, further comprising;  
an adapter ring for connection to the distal end of the body portion; and  
a flexible arm extending from the body portion and connected to the adapter ring.

26. A seal for use in combination with an elongate device, an endoscope, and a compression mechanism, the elongate device having a shaft, the endoscope having a proximal end and a working channel extending therethrough, the seal comprising:

a body portion having a proximal end adapted for insertion of the elongate device, a distal end adapted for connection to the proximal end of the endoscope, and a variable diameter wall defining a variable diameter lumen extending therethrough adapted to receive the elongate device and to provide access to the working channel of the endoscope wherein the compression mechanism is disposed about the body portion for compressing the variable diameter wall to thereby vary the diameter of the lumen extending therethrough and seal about the shaft.

27. A seal for use in combination with an elongate device and an endoscope, the elongate device having a shaft with a slot extending therethrough, the endoscope having a proximal end and a working channel extending therethrough, the seal comprising:

a body portion having a proximal end adapted for insertion of the elongate device, a distal end adapted for connection to the proximal end of the endoscope, and a membrane having an aperture adapted to receive the shaft of the elongate device; and

a mandrel having a geometry conforming to the slot in the shaft, the mandrel disposed in the slot and the aperture such that a fluid seal is established thereby.

28. A seal for use in combination with a primary device and a secondary device insertable in the primary device, the secondary device having a shaft, the primary device having a proximal end and a lumen extending therethrough, the seal comprising:

a body portion having a proximal end adapted for insertion of the secondary device, a distal end adapted for connection to the proximal end of the primary device, and a wall defining a lumen extending therethrough adapted to receive the secondary device and to provide access to the lumen of the primary device; and

at least one protrusion disposed in the lumen of the body portion, the protrusion extending radially inward from the wall to sealingly engage the shaft of the secondary device.

29. A seal as in claim 28, wherein a plurality of protrusions are utilized.

30. A seal as in claim 29, wherein the protrusions are uniformly spaced about the wall defining the lumen.

31. A seal as in claim 30, wherein the protrusions are sufficiently flexible to conform to a non-circular shaft.

32. A seal as in claim 4, wherein the non-circular shaft comprises a shaft of a rapid-exchange type catheter.

33. A seal as in claim 32, wherein the non-circular shaft includes a slot therein.

34. A seal as in claim 33, wherein the non-circular shaft includes a c-shaped channel therein.

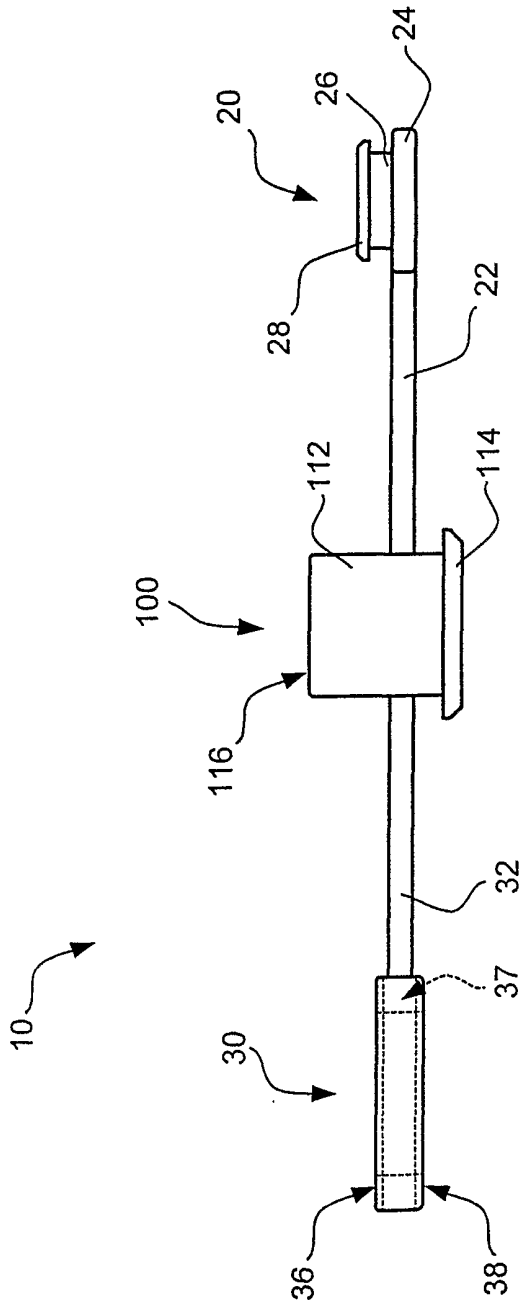

FIG. 1A

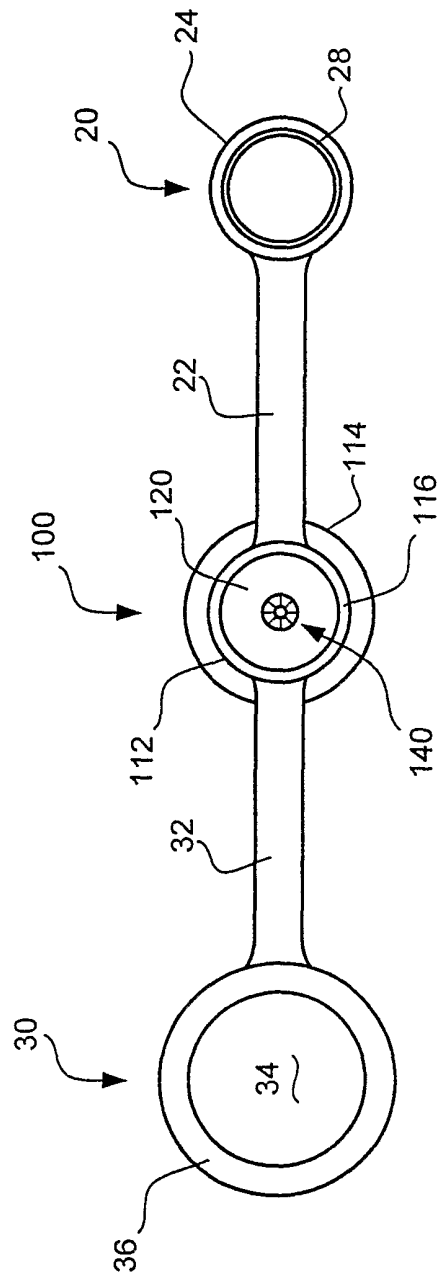

FIG. 1B

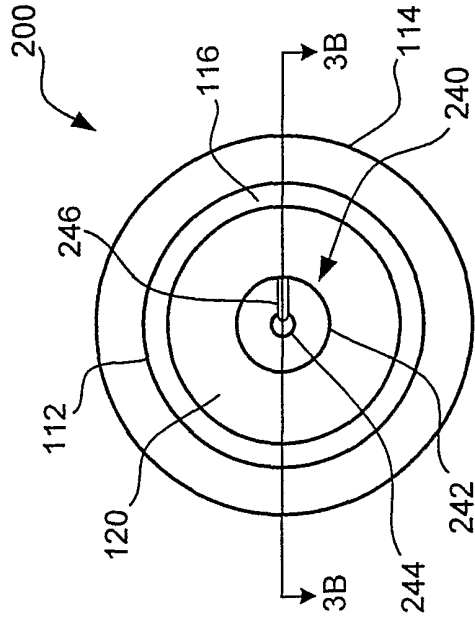

FIG. 3A

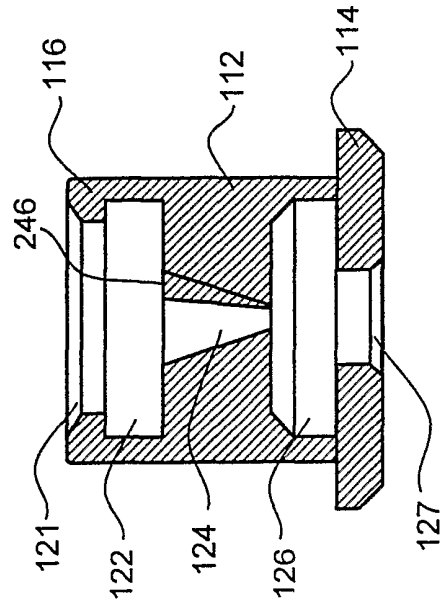

FIG. 3B

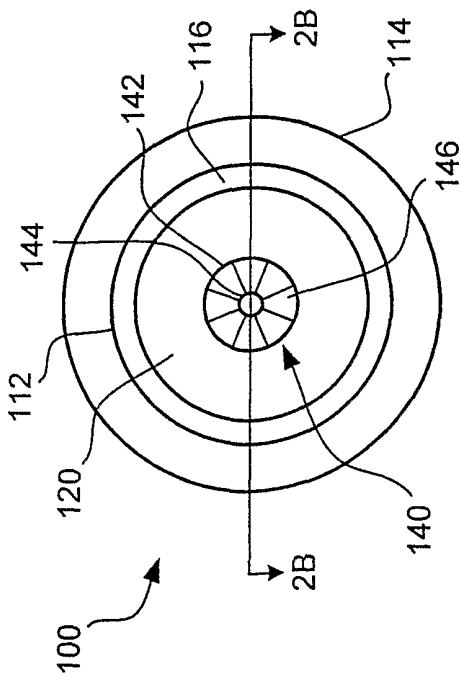

FIG. 2A

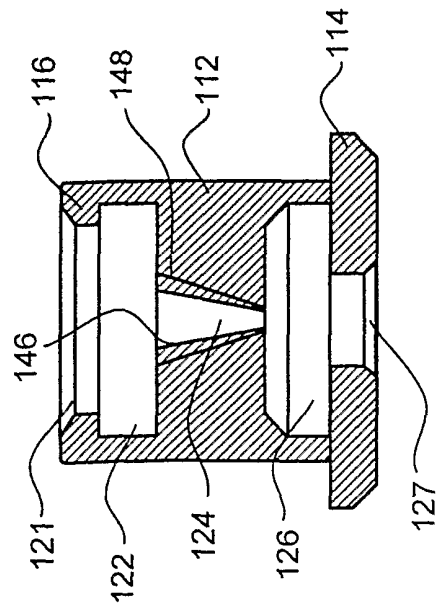

FIG. 2B

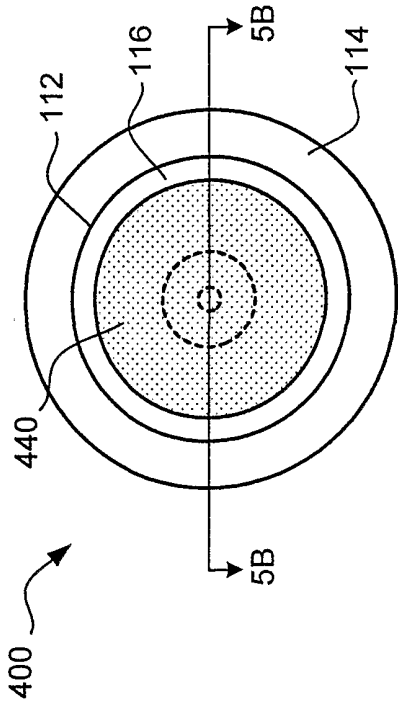

FIG. 4A

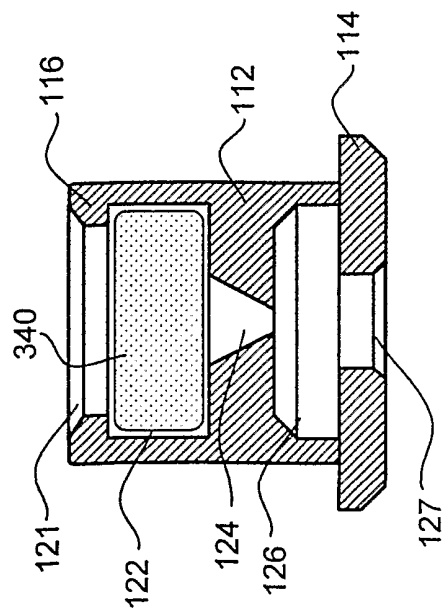
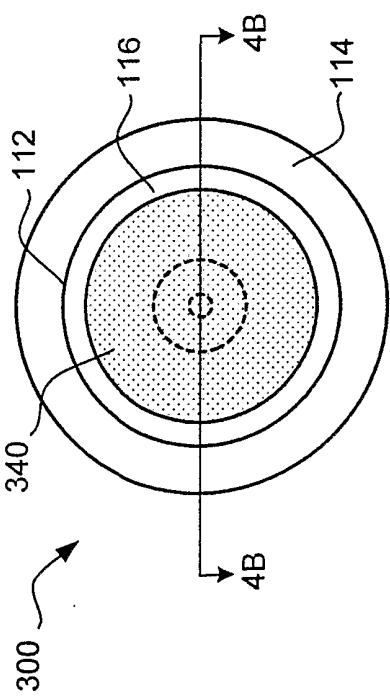

FIG. 4B

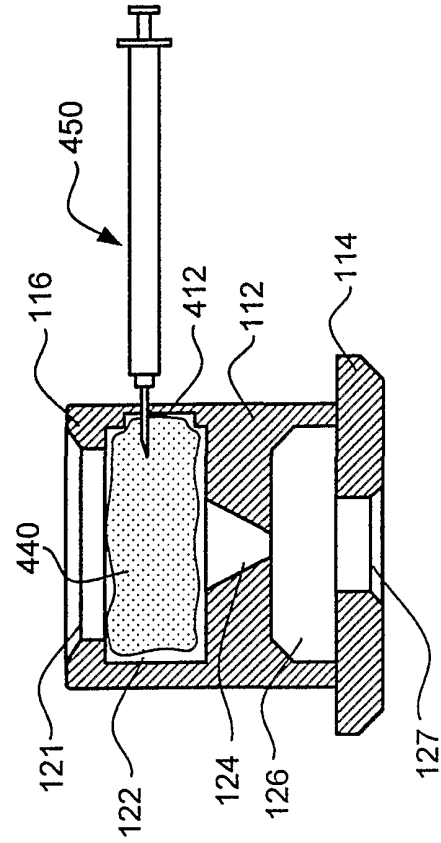

FIG. 5A

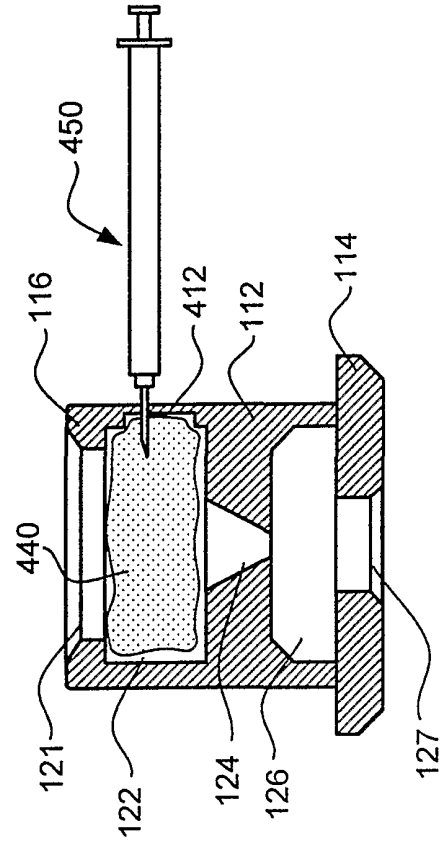
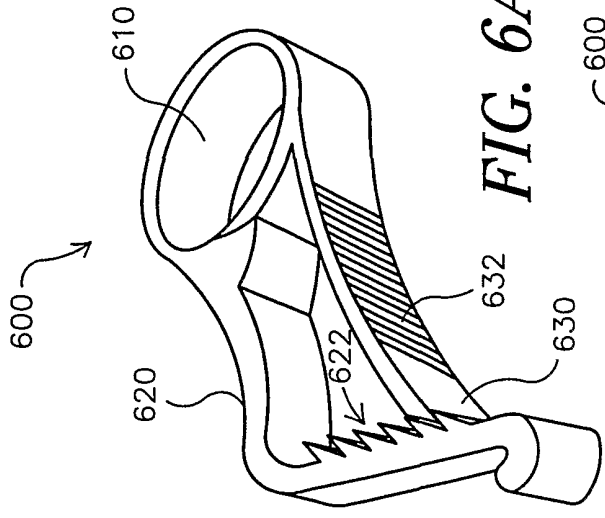
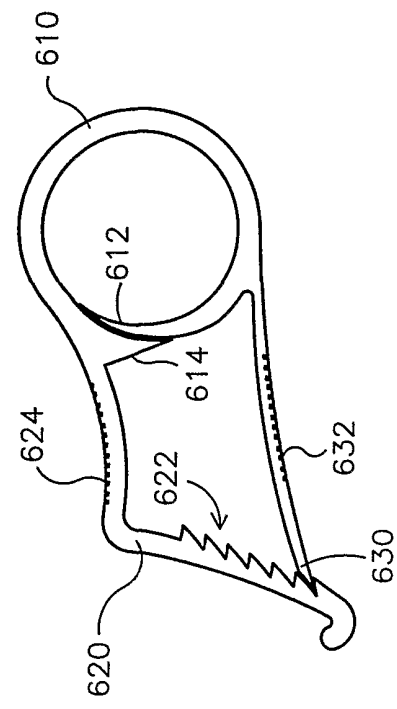

FIG. 5B



**FIG. 6A**



**FIG. 6B**

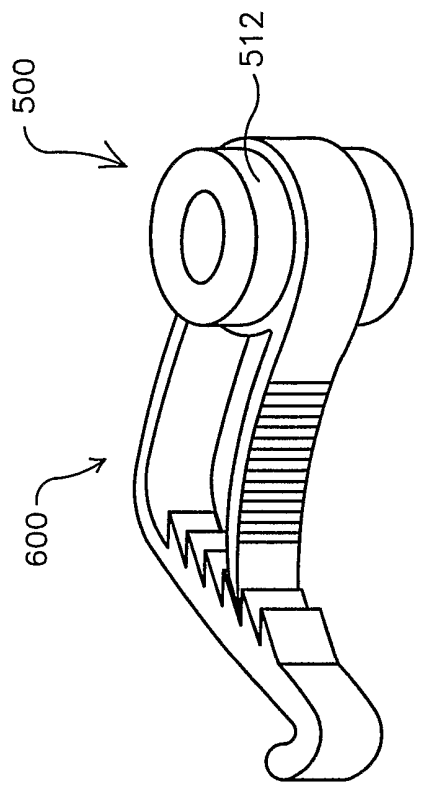

**FIG. 6C**

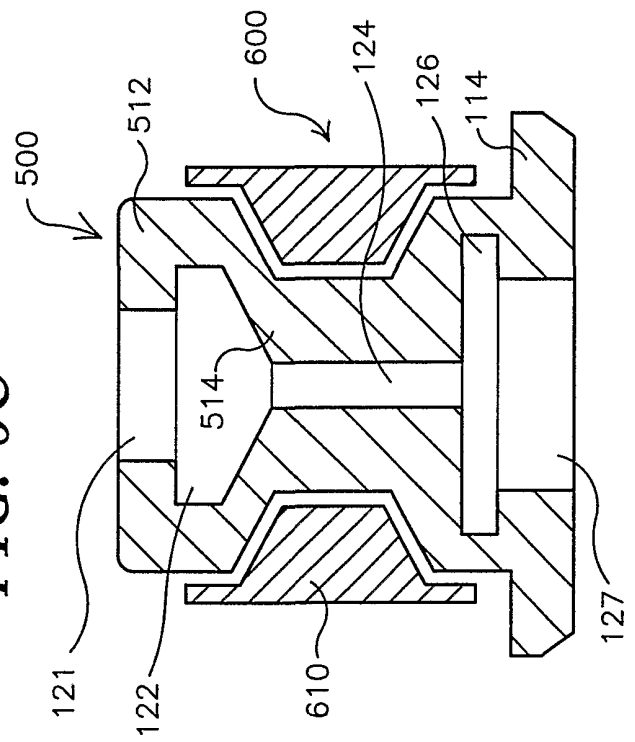

**FIG. 6D**

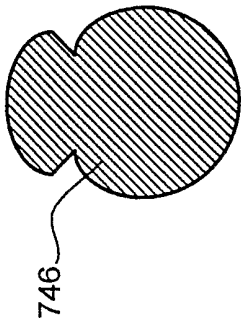

**FIG. 7C**

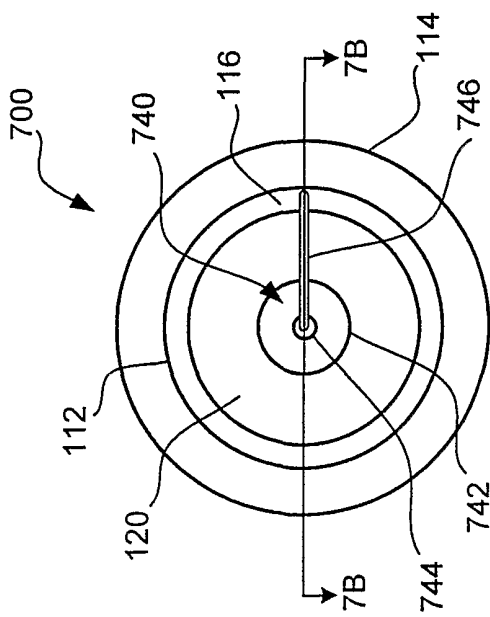

**FIG. 7A**

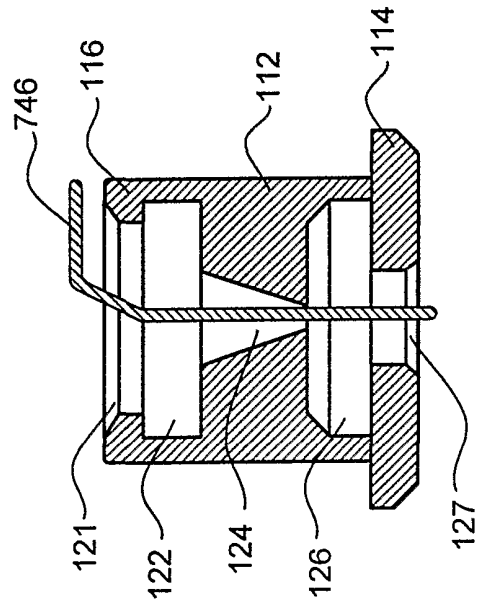

**FIG. 7B**