

J. H. McGowan,
Tobacco Press,
No 79,769, Patented July 7, 1868.

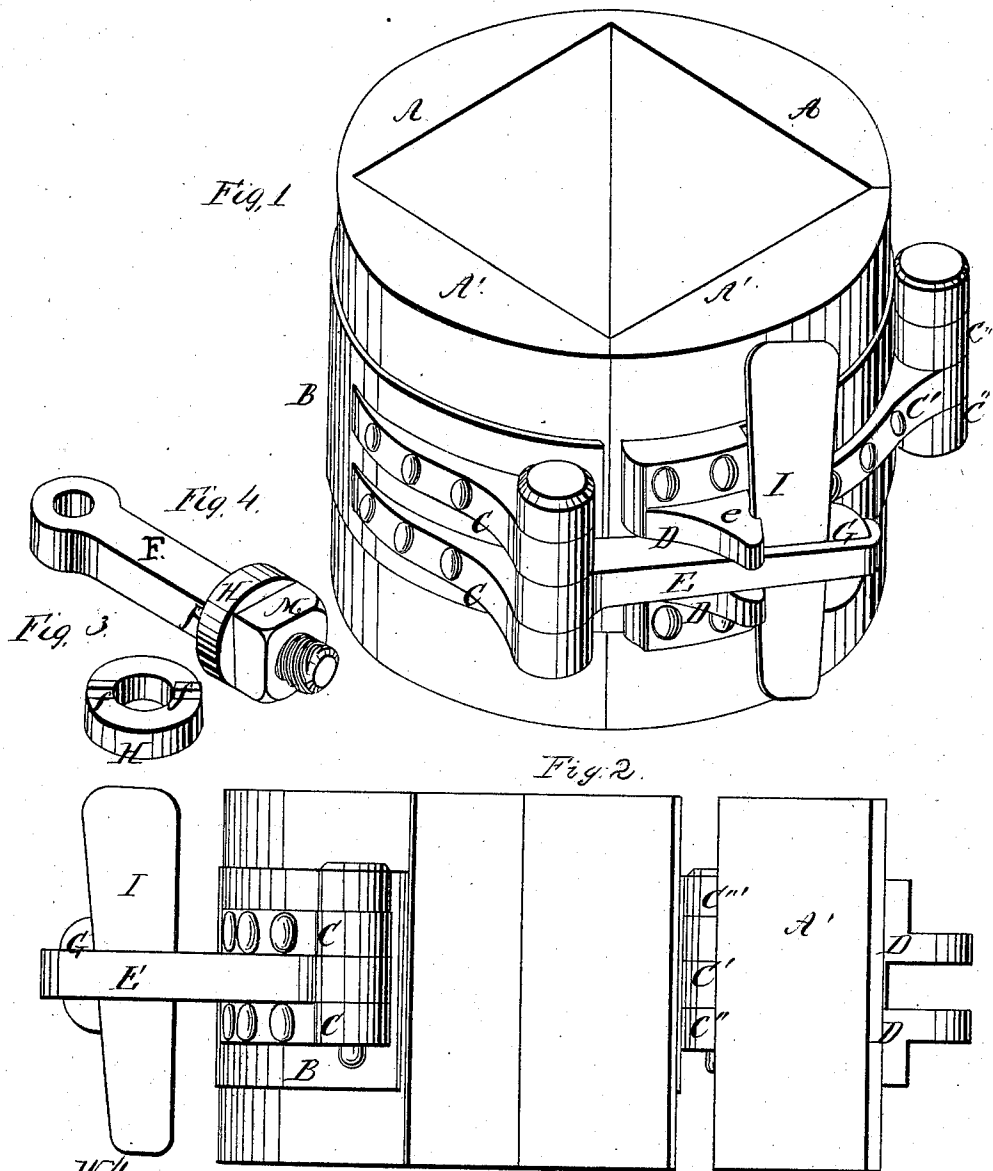

Witnesses;
Moritz B. Philipp
James Moore

Inventor;
John H. McGowan

United States Patent Office.

JOHN H. MCGOWAN, OF CINCINNATI, OHIO.

Letters Patent No. 79,769, dated July 7, 1868.

IMPROVED TOBACCO-COMPRESS.

The Schedule referred to in these Letters Patent and making part of the same.

TO ALL WHOM IT MAY CONCERN:

Be it known that I, JOHN H. MCGOWAN, of Cincinnati, in the county of Hamilton, and State of Ohio, have invented certain new and useful Improvements in Tobacco-Compresses and Box-Casing; and I do hereby declare that the following is a full, clear, and exact description of the construction and operation of the same, reference being had to the annexed drawings, making part of this specification, in which—

Figure 1 is a perspective view of a compressor or box-casing.

Figure 2 is a vertical front view of the same, with one of the segments forming the door thrown open.

Figure 3 is a perspective view of the feathered collar H, showing projections *ff*.

Figure 4 is the swing-bolt F, showing the collar H fitted on and made fast by the nut M.

Similar letters refer to similar parts in all the figures.

The nature of my invention consists in new modes of binding a compress or finisher, and also box-casing, while they are being pressed. Some of the advantages arising from the use of my invention are—

First, there is no danger of the arrangement for binding the box-casing or compress slipping and the door flying open, by reason of the great pressure necessary, as is often the case with the modes of fastening at present in use.

Second, the box-casing or compress is held more firmly, because of the greater strength of each of my modes of fastening.

Third, the box of tobacco may be removed from the casing, and another box inserted, without removing the casing from the press, thereby saving much time and labor.

In order that others skilled in the art may be enabled to make and use my invention, I will proceed to describe its construction and mode of operation.

A A A A are segments, whose inner edges are chords of the arcs of the circle formed by their exterior edges.

B is a band of brass or other metal, completely surrounding the segments A' A A A.

C C C' C' are lugs bolted or riveted to the band B, or formed as part of the same in one piece.

E and F are swinging bolts, either of which may be hinged in the lugs C C, as shown at fig. 1.

D D are ears riveted or bolted to the band B, or formed in one piece with it. They are perpendicular to the said band, and parallel to each other, as shown at fig. 1.

On the edge of the ears D D, toward the lugs C' C', and parallel with the plane of the band B, are slots *e*, cut sufficiently deep to give a secure fastening to the key I, when the apparatus is used either as a compress or as box-casing.

I is a wedge-shaped key, of the requisite thickness to fit in the slots *e*.

A slot is cut through the swing-bolt E, in one end of which a gib, G, fig. 1, is made fast as a brace for key I.

The segments A' A A A are so fitted to each other and to the band B that they do not fit perfectly tight against each other where they meet, and before being drawn together by the nut M on the swinging bolt F, or by the key I being driven tightly into the swing-bolt E, and this play is permitted by having slots in the band B, which will slide along the screws or rivets, by which the band is held to the segments.

In this manner tobacco can be put more easily into the compress or box-casing, and afterward made sufficiently tight by the nut M, when the swing-bolt F is used, or by the key I, when the swing-bolt E is used.

Segment A' is the door of the box-casing or compress, which opens on the hinge C', as shown at fig. 2, when it is desired to put in or take the tobacco out of the compress, or to take the box of tobacco out of the box-casing when sufficiently pressed.

H is a feathered collar, made to fit loosely on the swing-bolt F, as shown at fig. 4. On it are projections *ff*, to fit into the interstices or slots *e*, so as to prevent it from turning or slipping when the nut M is screwed on to the swing-bolt F, and also to give a firm gripe to the said nut, and thereby prevent it from slipping or getting loose when under great pressure.

When it is desired to close the compress for use, the swing-bolt E is turned around until it enters between the ears D D, which are just sufficiently far apart for either of the swing-bolts to enter between them with ease, and at the same time be held firmly when the key I is inserted in the slot in the swing-bolt, its edge also cutting the slots *e* in the ears D D, when it is driven down until the band draws the segments together, when the whole is ready to be pressed.

The swing-bolt F may also be hinged at C C, and will enter between the ears D D in the same manner as the bolt E, when the feathered collar H should be put on, the projections *ff* entering the notches or slots *e* in the ears D D, where it is held by the nut M, by which the segments are drawn together.

Having thus described my invention, what I claim as new, and desire to secure by Letters Patent, is—

The ears D D, provided with the slots *e e*, in combination with the swing-bolt E and key I, or swing-bolt F, and collar H, connected, arranged, and operating substantially as described.

JOHN H. MCGOWAN.

Witnesses:

JAMES MOORE,
MORITZ B. PHILIPP.