

(19) **DANMARK**

(10) **DK 2019 70633 A1**



(12) **PATENTANSØGNING**

Patent- og
Varemærkestyrelsen

-
- (51) Int.Cl.: **H01B 11/02 (2006.01)** **H01B 7/02 (2006.01)**
- (21) Ansøgningsnummer: **PA 2019 70633**
- (22) Indleveringsdato: **2019-10-09**
- (24) Løbedag: **2019-10-09**
- (41) Alm. tilgængelig: **2020-04-12**
- (43) Publiceringsdato: **2020-05-18**
- (30) Prioritet:
62/744,589 2018-10-11 US
- (71) Ansøger:
Apitiv Technologies Limited, Erin Court, Bishop's Court Hill St. Michael BB14004, Barbados
- (72) Opfinder:
Christian Schäfer, Dumbergweg 18 Bochum D 44879, Tyskland
Guido Woeste, Pastor-Nonne-Strasse 23 A 58332 Schweim, Tyskland
- (74) Fuldmægtig:
Aera A/S, Gammel Kongevej 60, 18. sal, 1850 Frederiksberg C, Danmark
- (54) Titel: **AUTOMOTIVE COMMUNICATIONS CABLE**
- (56) Fremdragne publikationer:
US 5313020 A
US 5120905 A
CN 205194363 U
GB 344194 A
EP 1343178 A1
US 2008/0128151 A1
US 2014/0251652 A1
- (57) Sammendrag:
An example communications cable includes a cable jacket, a pair of twisted conductors disposed within the cable jacket, and two or more insulating strands disposed within the cable jacket. The two or more insulating strands include a central insulating strand disposed between a first conductor in the pair of twisted conductors and a second conductor in the pair of twisted conductors.

Fortsættes...

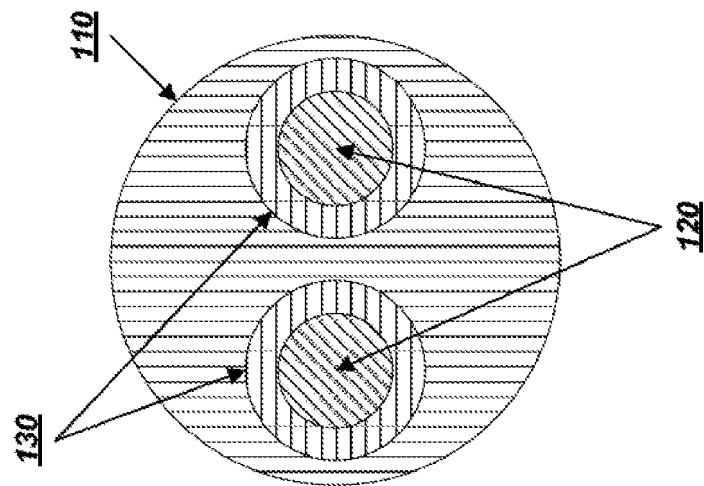

FIG. 1A

AUTOMOTIVE COMMUNICATIONS CABLE

TECHNICAL FIELD

[0001] This specification relates to automotive communications cables.

BACKGROUND

[0002] Modern vehicles have dozens of electronic control units (ECUs) that obtain sensor data, process the sensor data to generate output signals, and provide the output signals to particular vehicle components that perform actions based on the output signals. For
5 example, a transmission control unit can obtain engine speed data, vehicle speed data, and throttle position data and generate an output signal that defines a desired gear for a vehicle. If the vehicle is not in the desired gear, the transmission can shift to the desired gear in response to the output signal.

[0003] Semi-autonomous and autonomous vehicles generally have an even greater
10 number of ECUs than human-operated vehicles because sensor inputs replace some or all human inputs, and those additional sensor inputs must be processed. Moreover, semi-autonomous and autonomous vehicles often include redundant systems in order to satisfy safety requirements.

[0004] Generally, each ECU in a vehicle is connected to a central communications
15 network over which the ECUs can exchange data with each other, with external sensors, and with other components of the vehicle. The central communications network includes a number of communications cables that are costly to manufacture and add significant weight to the vehicle. The communications cables in vehicles are generally jacketed unshielded twisted pairs (JUPTs).

SUMMARY

20 [0005] This specification describes an improved communications cable. The communications cable includes a pair of twisted conductors disposed within a cable jacket. Two or more insulating strands are also disposed within the cable jacket. The two or more

insulating strands include a central insulating strand disposed between a first conductor in the pair of twisted conductors and a second conductor in the pair of twisted conductors.

[0006] The subject matter described in this specification can be implemented in particular embodiments so as to realize one or more of the following advantages. First, the improved communications cable weighs less than a conventional JUPT of the same wire gauge. This is because the lack of an individual insulator for each conductor allows the cable jacket to have a smaller diameter, which reduces the weight of the communications cable due to the cable jacket.

[0007] The improved communications cable is cheaper and easier to manufacture than a conventional JUPT because the conductors in the improved communications cable do not have their own insulator. Instead, the improved communications cable has insulating strands that can be extruded at the same time using the same extrusion process, which further simplifies the manufacturing process.

[0008] The use of separate insulating strands also provides flexibility in adjusting the relative permittivity of the cable, since the size and material composition of each insulating strand can be adjusted as necessary.

[0009] Finally, the improved communications cable can also be stripped more easily than a conventional JUPT, i.e., by removing the cable jacket and the exterior insulating strands in one stripping process. The central insulating strand holds the conductors in a fixed position, allowing defined insertion into a connector through laser welding or crimping. Additionally, the central insulating strand helps to maintain the twist in the communications cable for the entire length of the cable. This increases noise immunity.

[0010] The details of one or more embodiments of the subject matter of this specification are set forth in the accompanying drawings and the description below. Other features, aspects, and advantages of the subject matter will become apparent from the description, the drawings, and the claims.

BRIEF DESCRIPTION OF THE DRAWINGS

FIG. 1A is a diagram of a cross-section of a conventional JUPT, according to an embodiment.

FIG. 1B is a diagram of a cross-section of an improved communications cable, according to an embodiment.

5 FIG. 2 is a diagram of a side view of the improved communications cable, according to an embodiment.

FIG. 3A is a flow chart of an example process for stripping the improved communications cable, according to an embodiment.

10 FIG. 3B is a diagram of a cross-section of a stripped version of the improved communications cable, according to an embodiment.

FIG. 4 is a flow chart of an example process for manufacturing the improved communications cable, according to an embodiment.

Like reference numbers and designations in the various drawings indicate like elements.

DETAILED DESCRIPTION

15 **[0011]** Reference will now be made in detail to embodiments, examples of which are illustrated in the accompanying drawings. In the following description, for the purposes of explanation, numerous specific details are set forth in order to provide a thorough understanding of the present invention. It will be apparent, however, that the present invention may be practiced without these specific details. In other instances, well-known
20 structures and devices are shown in block diagram form in order to avoid unnecessarily obscuring the disclosed embodiments.

[0012] In the drawings, specific arrangements or orderings of schematic elements, such as those representing devices, modules, instruction blocks and data elements, are shown for ease of description. However, it should be understood by those skilled in the art that the
25 specific ordering or arrangement of the schematic elements in the drawings is not meant to imply that a particular order or sequence of processing, or separation of processes, is

required. Further, the inclusion of a schematic element in a drawing is not meant to imply that such element is required in all embodiments or that the features represented by such element may not be included in or combined with other elements in some embodiments.

[0013] Further, in the drawings, where connecting elements, such as solid or dashed lines or arrows, are used to illustrate a connection, relationship or association between or among two or more other schematic elements, the absence of any such connecting elements is not meant to imply that no connection, relationship or association can exist. In other words, some connections, relationships or associations between elements are not shown in the drawings so as not to obscure the disclosure. In addition, for ease of illustration, a single connecting element is used to represent multiple connections, relationships or associations between elements. For example, where a connecting element represents a communication of signals, data or instructions, it should be understood by those skilled in the art that such element represents one or multiple signal paths (e.g., a bus), as may be needed, to affect the communication.

[0014] Several features are described hereafter that can each be used independently of one another or with any combination of other features. However, any individual feature may not address any of the problems discussed above or might only address one of the problems discussed above. Some of the problems discussed above might not be fully addressed by any of the features described herein. Although headings are provided, information related to a particular heading, but not found in the section having that heading, may also be found elsewhere in the specification.

[0015] FIG. 1A is a diagram of a cross-section of a conventional JUPT. The conventional JUPT has a cable jacket 110. Two conductors 120, each surrounded by insulators 130, are disposed within the cable jacket 110.

[0016] FIG. 1B is a diagram of a cross-section of an improved communications cable. The communications cable includes a cable jacket 140, five insulating strands 150, and two conductors 120 that are identical to the conductors 120 in FIG. 1A.

[0017] The cable jacket 140 provides mechanical support to the communications cable and electrically insulates the conductors 120 from the environment. The cable jacket 140 is

generally a hollow cylinder and can be made of any appropriate electrical insulator, e.g., any appropriate plastic or rubber material that has enough flexibility to allow insertion into a vehicle.

[0018] The conductors 120 are fully disposed within the cable jacket 140. The
5 conductors 120 can be any appropriate electrical conductors. For example, the conductors 120 can be copper litz wire, which is made of wound strands of copper wire. Alternatively, the conductors 120 can be solid conductors, e.g., single pieces of copper.

[0019] The insulating strands 150 are fully disposed within the cable jacket 140 and are generally cylindrical in shape. A central insulating strand disposed between the two
10 conductors 120 separates them from each other. The insulating strands 150 can be made of polytetrafluoroethylene (PTFE), fluorinated ethylene propylene (FEP), or any other suitable material. The use of separate insulating strands provides flexibility in adjusting the relative permittivity of the cable, since the size and material composition of each insulating strand can be adjusted as necessary. The improved communications cable has a smaller diameter than a
15 conventional JUPT, which reduces its weight and intrinsic impedance.

[0020] FIG. 2 is a diagram of a side view of the improved communications cable described in reference to FIG. 1B. FIG. 2 depicts the communications cable without the cable jacket 140.

[0021] For simplicity, FIG. 2 depicts an untwisted implementation of the improved
20 communications cable described in reference to FIG. 1B. In some implementations, however, the conductors 120 are twisted about each other. Twisting the conductors 120 reduces the amount of electromagnetic radiation that the communications cable generates and improves rejection of external electromagnetic interference.

[0022] FIG. 3A is a flow chart of an example process 300 for stripping the improved
25 communications cable described in reference to FIG. 1B. The process can be performed by a person or by an automated machine that is configured to do so. For convenience, the process will be described as being performed by a person.

[0023] Using conventional wire strippers, a person exposes the conductors by stripping the cable jacket and the four exterior insulating strands away from the conductors in one

stripping process (310). This is not possible with a conventional JUPT, in which each conductor additionally has its own insulator that must be separately stripped. FIG. 3B is a diagram of a cross-section of a stripped version of the improved communications cable described in reference to FIG. 1B.

5 [0024] The person attaches the exposed conductors to a connector, e.g., by crimping, laser welding, or soldering the conductors to the connector (320). This is possible because the central insulating strand holds the conductors in place relative to each other. In contrast, after a person strips a conventional JUPT, the conductors are able to move relative to each other, which makes the above-mentioned attachment methods more difficult. Additionally, the
10 central insulating strand helps to maintain the twist in the communications cable for the entire length of the cable. This increases noise immunity.

[0025] FIG. 4 is a flow chart of an example process 400 for manufacturing the improved communications cable described in reference to FIG. 1B. For convenience, the process will be described as being performed by an automated system of one or more machines
15 and one or more computers.

[0026] The system extrudes each of the five insulating strands in one simple, standard process (410). The system twists the insulating strands with two conductors to form an assembly (420). The system twists the assembly while it is still hot from the extrusion process and then fixes the assembly in the twisted position (430). Fixing the assembly can involve
20 cooling the assembly. Finally, the system extrudes a cable jacket on the assembly (440).

[0027] The process 400 requires fewer extrusions than the manufacturing process for a conventional JUPT because the manufacturing process for a conventional JUPT includes extruding insulators on each conductor. The improved communications cable does not have separate insulators for each conductor but instead strands that can be extruded at the same time
25 using the same extrusion process, which further simplifies the manufacturing process.

[0028] While this document contains many specific implementation details, the implementation details should not be construed as limitations on the scope of what may be claimed but rather as a description of features that may be specific to particular embodiments. Certain features that are described in this specification in the context of separate embodiments

can also be implemented in combination in a single embodiment. Conversely, various features that are described in the context of a single embodiment can also be implemented in multiple embodiments separately or in any suitable sub combination. Moreover, although features may be described above as acting in certain combinations and even initially claimed as such, one or
5 more features from a claimed combination can, in some cases, be excised from the combination, and the claimed combination may be directed to a sub combination or variation of a sub combination.

[0029] While logic flows or operations are depicted in the drawings in a particular order, this should not be understood as requiring that such operations be performed in the
10 particular order shown or in sequential order, or that all illustrated operations be performed, to achieve desirable results. In certain circumstances, multitasking and parallel processing may be advantageous. Moreover, the separation of various software components in the embodiments described above should not be understood as requiring such separation in all embodiments, and it should be understood that the described software components can
15 generally be integrated together in a single software program or multiple software programs.

[0030] In some instances, functions in claims will be preceded with the phrase “one or more.” The phrase “one or more” as used herein includes a function being performed by one element, a function being performed by more than one element, e.g., in a distributed fashion, several functions being performed by one element, several functions being performed by
20 several elements, or any combination of the above.

In some instances, claim elements will be preceded with the terms first, second, third and so forth. It should be understood that, although the terms first, second, third, etc. are, in some instances, used herein to describe various elements, these elements should not be limited by these terms. These terms are only used to distinguish one element from another. For
25 example, a first contact could be termed a second contact, and, similarly, a second contact could be termed a first contact, without departing from the scope of the various described embodiments. The first contact and the second contact are both contacts, but they are not the same contact.

Disclosed is a communications cable, comprising: a cable jacket; a pair of twisted conductors disposed within the cable jacket; and two or more insulating strands disposed within the cable jacket, the two or more insulating strands including a central insulating strand disposed between a first conductor in the pair of twisted conductors and a second conductor in the pair of twisted conductors.

In one or more exemplary communication cables, the first conductor and the second conductor each lack their own insulator.

In one or more exemplary communication cables, the first conductor and second conductor are litz wire.

In one or more exemplary communication cables, the cable jacket is an electrical insulator.

In one or more exemplary communication cables, the two or more insulating strands comprise polytetrafluoroethylene.

In one or more exemplary communication cables, the two or more insulating strands comprise fluorinated ethylene propylene.

In one or more exemplary communication cables, the two or more insulating strands include a plurality of additional insulating strands disposed along a periphery of the central insulating strand.

In one or more exemplary communication cables, the plurality of additional insulating strands includes at least two insulating strands disposed on a first side of the central insulating strand, and at least two insulating strands disposed on a second side of the central insulating strand opposite the first side.

Disclosed is a method for attaching a communications cable to a connector, the communications cable comprising: a cable jacket; a pair of twisted conductors disposed within the cable jacket, two or more insulating strands disposed within the cable jacket, the two or more insulating strands including a central insulating strand disposed between a first conductor in the pair of twisted conductors and a second conductor in the pair of twisted conductor. The method comprises: exposing the pair of twisted conductors by stripping the

cable jacket and the insulating strands other than the central insulating strand; and attaching the exposed pair of twisted conductors to the connector.

In one or more exemplary methods, attaching comprises crimping.

In one or more exemplary methods, attaching comprises laser welding.

5 In one or more exemplary methods, attaching comprises soldering.

In one or more exemplary methods, the two or more insulating strands include a plurality of additional insulating strands disposed along a periphery of the central insulating strand, and wherein exposing the pair of twisted conductors comprises stripping the plurality of

10 additional insulating strands.

Disclosed is a method for manufacturing a communications cable, the communications cable comprising: a cable jacket; a pair of twisted conductors disposed within the cable jacket, two or more insulating strands disposed within the cable jacket, the two or more insulating

15 strands including a central insulating strand disposed between a first conductor in the pair of twisted conductors and a second conductor in the pair of twisted conductors. The method comprises: extruding the two or more insulating strands; twisting the two or more insulating strands with a pair of conductors to form an assembly; and extruding the cable jacket on the assembly.

20 In one or more exemplary methods, the two or more insulating strands include a plurality of additional insulating strands disposed along a periphery of the central insulating strand, and wherein twisting the two or more insulating strands with the pair of conductors to form the assembly comprises twisting the plurality of additional insulating strands with the pair of conductors.

25 In one or more exemplary methods, the two or more insulating strands are extruded concurrently.

In one or more exemplary methods, the two or more insulating strands are twisted with the pair of conductors during a period of time in which the two or more insulating strand retain heat from an extrusion process.

In one or more exemplary methods, the method comprises cooling the assembly.

In one or more exemplary methods, the method comprises forming the pair of conductors such that they each lack their own insulator.

In one or more exemplary methods, the two or more insulating strands are extruded from a
5 material comprising at least one of polytetrafluoroethylene or fluorinated ethylene propylene.

[0031] The terminology used in the description of the various described embodiments herein is for the purpose of describing particular embodiments only and is not intended to be limiting. As used in the description of the various described embodiments and the appended claims, the singular forms “a”, “an” and “the” are intended to include the plural forms as well,
10 unless the context clearly indicates otherwise. It will also be understood that the term “and/or” as used herein refers to and encompasses any and all possible combinations of one or more of the associated listed items. It will be further understood that the terms “includes,” “including,” “comprises,” and/or “comprising,” when used in this specification, specify the presence of stated features, integers, steps, operations, elements, and/or components, but do not preclude
15 the presence or addition of one or more other features, integers, steps, operations, elements, components, and/or groups thereof.

[0032] As used herein, the term “if” is, optionally, construed to mean “when” or “upon” or “in response to determining” or “in response to detecting,” depending on the context. Similarly, the phrase “if it is determined” or “if [a stated condition or event] is detected” is,
20 optionally, construed to mean “upon determining” or “in response to determining” or “upon detecting [the stated condition or event]” or “in response to detecting [the stated condition or event],” depending on the context.”

[0033] Some aspects of the subject matter of this specification may include gathering and use of data available from various sources. The present disclosure contemplates that in
25 some instances, this gathered data may identify a particular location or an address based on device usage. Such personal information data can include location-based data, addresses, subscriber account identifiers, or other identifying information. The present disclosure further contemplates that the entities responsible for the collection, analysis, disclosure, transfer, storage, or other use of such personal information data will comply with well-established

privacy policies and/or privacy practices. In particular, such entities should implement and consistently use privacy policies and practices that are generally recognized as meeting or exceeding industry or governmental requirements for maintaining personal information data private and secure.

CLAIMS

1. A communications cable, comprising:
a cable jacket;
a pair of twisted conductors disposed within the cable jacket; and
two or more insulating strands disposed within the cable jacket, the two or more
5 insulating strands including a central insulating strand disposed between a first conductor in
the pair of twisted conductors and a second conductor in the pair of twisted conductors.
2. The communications cable of claim 1, wherein the first conductor and the second
conductor each lack their own insulator.
- 10 3. The communications cable of any of claims 1-2, wherein the first conductor and
second conductor are litz wire.
4. The communications cable of any of claims 1-3, wherein the cable jacket is an
15 electrical insulator.
5. The communications cable of any of claims 1-4, wherein the two or more insulating
strands comprise polytetrafluoroethylene.
- 20 6. The communications cable of any of claims 1-5, wherein the two or more insulating
strands comprise fluorinated ethylene propylene.
7. The communications cable of any of claims 1-6, wherein the two or more insulating
strands include a plurality of additional insulating strands disposed along a periphery of the
25 central insulating strand.

8. The communications cable of claim 7, wherein the plurality of additional insulating strands includes at least two insulating strands disposed on a first side of the central insulating strand, and at least two insulating strands disposed on a second side of the central insulating strand opposite the first side.

5

9. A method for attaching a communications cable to a connector, the communications cable comprising:

a cable jacket;

a pair of twisted conductors disposed within the cable jacket,

10

two or more insulating strands disposed within the cable jacket, the two or more insulating strands including a central insulating strand disposed between a first conductor in the pair of twisted conductors and a second conductor in the pair of twisted conductors,

the method comprising:

exposing the pair of twisted conductors by stripping the cable jacket and the

15

insulating strands other than the central insulating strand; and

attaching the exposed pair of twisted conductors to the connector.

10. The method of claim 9, wherein attaching comprises crimping.

20

11. The method of any of claims 9-10, wherein attaching comprises laser welding.

12. The method of any of claims 9-11, wherein attaching comprises soldering.

25

13. The method of any of claims 9-12, wherein the two or more insulating strands include a plurality of additional insulating strands disposed along a periphery of the central insulating strand, and

wherein exposing the pair of twisted conductors comprises stripping the plurality of additional insulating strands.

14. A method for manufacturing a communications cable, the communications cable comprising:

a cable jacket;

a pair of twisted conductors disposed within the cable jacket,

5 two or more insulating strands disposed within the cable jacket, the two or more insulating strands including a central insulating strand disposed between a first conductor in the pair of twisted conductors and a second conductor in the pair of twisted conductors,

the method comprising:

extruding the two or more insulating strands;

10 twisting the two or more insulating strands with a pair of conductors to form an assembly; and

extruding the cable jacket on the assembly.

15 15. The method of claim 14, wherein the two or more insulating strands include a plurality of additional insulating strands disposed along a periphery of the central insulating strand, and

wherein twisting the two or more insulating strands with the pair of conductors to form the assembly comprises twisting the plurality of additional insulating strands with the pair of conductors.

20

16. The method of any of claims 14-15, wherein the two or more insulating strands are extruded concurrently.

25 17. The method of any of claims 14-16, wherein the two or more insulating strands are twisted with the pair of conductors during a period of time in which the two or more insulating strand retain heat from an extrusion process.

18. The method of any of claims 14-17, further comprising cooling the assembly.

19. The method of any of claims 14-18, the method comprising forming the pair of conductors such that they each lack their own insulator.
20. The method of any of claims 14-19, wherein the two or more insulating strands are
5 extruded from a material comprising at least one of polytetrafluoroethylene or fluorinated ethylene propylene.

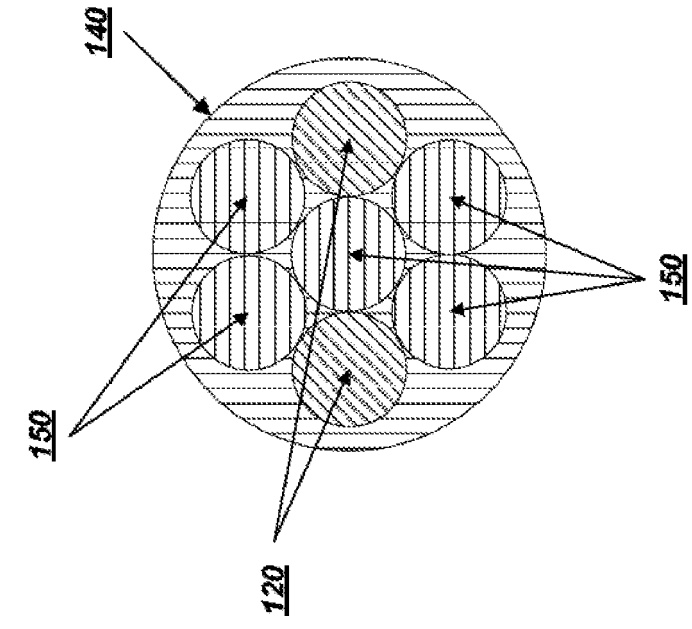

FIG. 1A

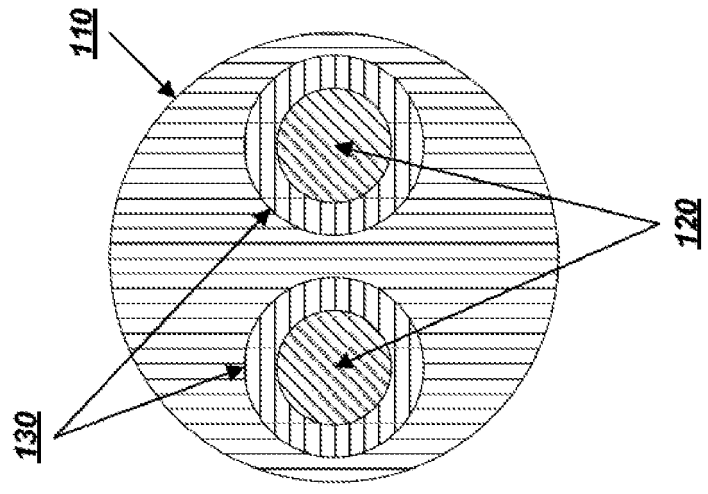

FIG. 1B

2/4

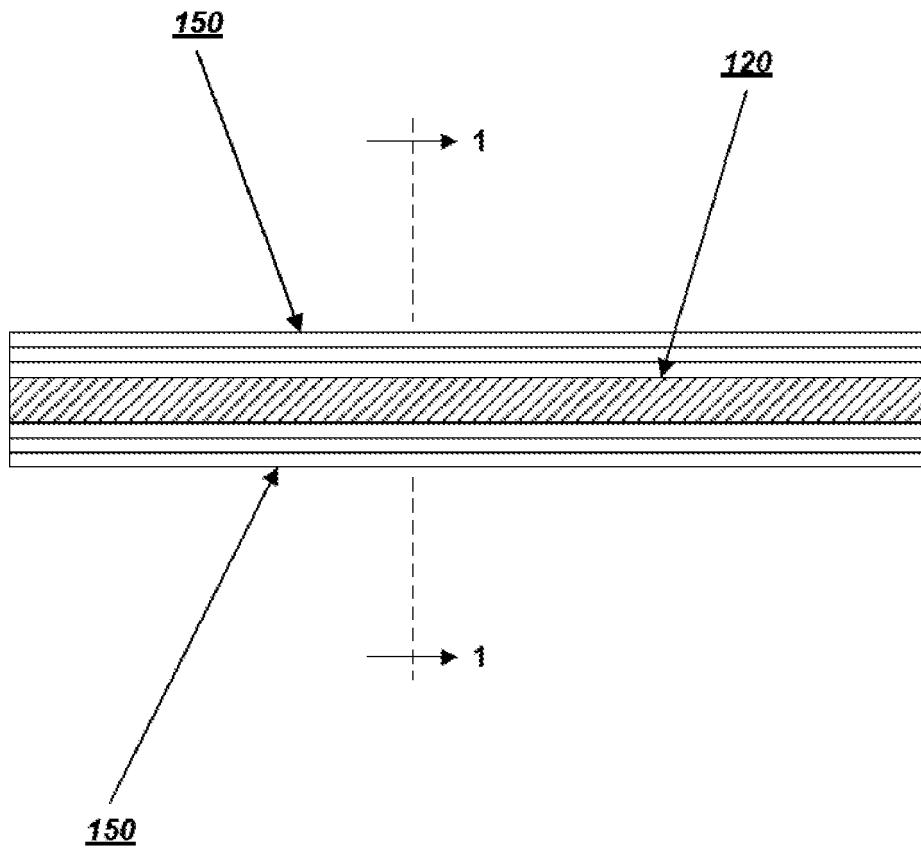

FIG. 2

3/4

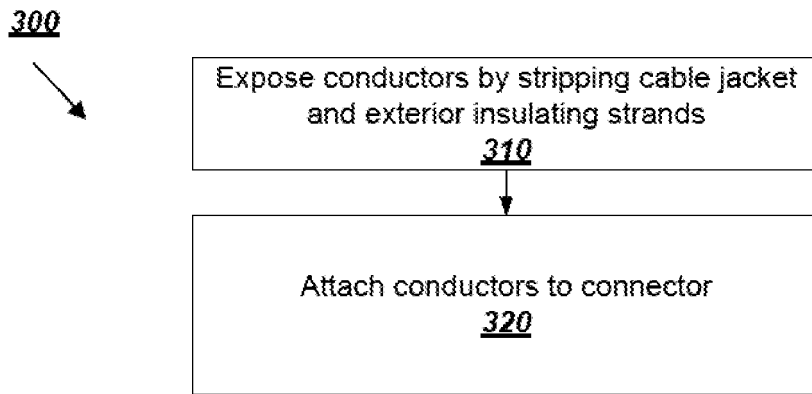

FIG. 3A

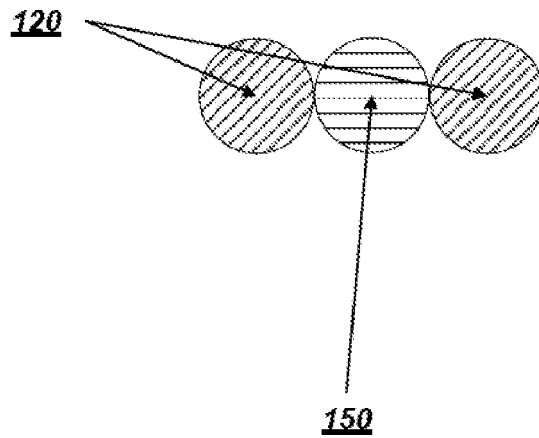

FIG. 3B

4/4

400

FIG. 4

SEARCH REPORT - PATENT		Application No. PA 2019 70633
1. <input type="checkbox"/> Certain claims were found unsearchable (See Box No. I).		
2. <input type="checkbox"/> Unity of invention is lacking prior to search (See Box No. II).		
A. CLASSIFICATION OF SUBJECT MATTER H 01 B 11/02 (2006.01); H 01 B 7/01 (2006.01) According to International Patent Classification (IPC)		
B. FIELDS SEARCHED		
PCT-minimum documentation searched (classification system followed by classification symbols) IPC&CPC: H01B		
Documentation searched other than minimum documentation to the extent that such documents are included in the fields searched		
Electronic database consulted during the search (name of database and, where practicable, search terms used) EPODOC, WPI, FULL-TEXT: ENGLISH		
C. DOCUMENTS CONSIDERED TO BE RELEVANT		
Category*	Citation of document, with indication, where appropriate, of the relevant passages	Relevant for claim No.
X	<u>US 5313020</u> A (SACKETT, JA) 1994.05.17, column 2 line 38 – column 3 line 11, column 4 line 22 – column 6 line 50 and Fig. 6-7	1-20
X	<u>US 5120905</u> A (COUSIN, J-C et al.) 1992.06.09, column 3 lines 14 – column 4 line 18 and Fig. 1-3	1-20
X	<u>CN 205194363</u> U (JINAN RUITONG RAILWAY ELECTRIC SERVICE CO LTD) 2016.04.27, Fig. 2	1-20
X	<u>EP 1343178</u> A1 (NEXANS [FR]) 2003.09.10, Par. [0011]-[0017] and figures	1-20
X	<u>GB 344194</u> A (PIRELLI GENERAL CABLE WORKS) 1931.03.05, page 2 right column line 103 – page 3 left column line 13, page 3 left column lines 26-35, page 3 left column line 59 - page 3 right column line 1 and Fig. 8	1-20
<input checked="" type="checkbox"/> Further documents are listed in the continuation of Box C.		
* Special categories of cited documents: "A" Document defining the general state of the art which is not considered to be of particular relevance. "D" Document cited in the application. "E" Earlier application or patent but published on or after the filing date. "L" Document which may throw doubt on priority claim(s) or which is cited to establish the publication date of another citation or other special reason (as specified). "O" Document referring to an oral disclosure, use, exhibition or other means.	"P" Document published prior to the filing date but later than the priority date claimed. "T" Document not in conflict with the application but cited to understand the principle or theory underlying the invention. "X" Document of particular relevance; the claimed invention cannot be considered novel or cannot be considered to involve an inventive step when the document is taken alone. "Y" Document of particular relevance; the claimed invention cannot be considered to involve an inventive step when the document is combined with one or more other such documents, such combination being obvious to a person skilled in the art. "&" Document member of the same patent family.	
Danish Patent and Trademark Office Helgeshøj Allé 81 DK-2630 Taastrup Denmark Telephone No. +45 4350 8000 Facsimile No. +45 4350 8001	Date of completion of the search report 04 December 2019	
	Authorized officer Lara Scolari Telephone No. +45 43 50 82 91	

SEARCH REPORT - PATENT		Application No. PA 2019 70633
C (Continuation). DOCUMENTS CONSIDERED TO BE RELEVANT		
Category*	Citation of document, with indication, where appropriate, of the relevant passages	Relevant for claim No.
X	<u>US 2008/0128151</u> A1 (DEBLADIS, F et al.) 2008.06.05, Par. [0006]-[0007], [0026]-[0035] and Fig. 2	1-20
A	<u>US 2014/0251652</u> A1 (POULSEN, JA et al.) A1 2014.09.11, abstract, Par. [0144] and [0163] and Fig. 16	1-20

Box No. I Observations where certain claims were found unsearchable

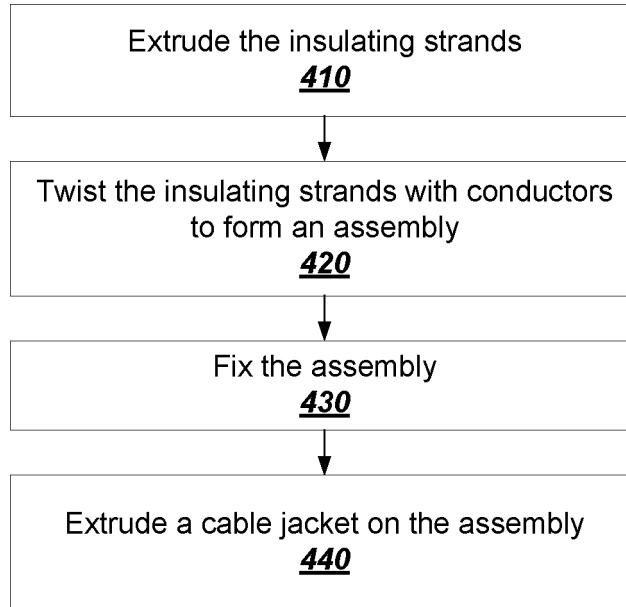
This search report has not been established in respect of certain claims for the following reasons:

1. Claims Nos.:

because they relate to subject matter not required to be searched, namely:

2. Claims Nos.:

because they relate to parts of the patent application that do not comply with the prescribed requirements to such an extent that no meaningful search can be carried out, specifically:

3. Claims Nos.:

because of other matters.

Box No. II Observations where unity of invention is lacking prior to the search

The Danish Patent and Trademark Office found multiple inventions in this patent application, as follows:

SUPPLEMENTAL BOX

Continuation of Box [.]