



(11) **EP 3 121 900 A1**

(12) **EUROPEAN PATENT APPLICATION**
published in accordance with Art. 153(4) EPC

(43) Date of publication:
25.01.2017 Bulletin 2017/04

(51) Int Cl.:
H01Q 13/02 (2006.01)

(21) Application number: **14891056.5**

(86) International application number:
PCT/CN2014/076655

(22) Date of filing: **30.04.2014**

(87) International publication number:
WO 2015/165098 (05.11.2015 Gazette 2015/44)

(84) Designated Contracting States:
AL AT BE BG CH CY CZ DE DK EE ES FI FR GB GR HR HU IE IS IT LI LT LU LV MC MK MT NL NO PL PT RO RS SE SI SK SM TR
Designated Extension States:
BA ME

(72) Inventor: **CAI, Yunlong**
Shenzhen
Guangdong 518129 (CN)

(71) Applicant: **Huawei Technologies Co. Ltd.**
Shenzhen, Guangdong 518129 (CN)

(74) Representative: **Pfenning, Meinig & Partner mbB**
Patent- und Rechtsanwälte
Joachimsthaler Straße 12
10719 Berlin (DE)

(54) **POWER FEEDER**

(57) Embodiments of the present invention disclose a feeding apparatus, which may include a horn antenna 10, a dielectric substrate 20, and a transmission line 30 and a grounding portion 40 that are disposed on the dielectric substrate 20, where the horn antenna 10 includes a horn opening end 11 and a horn feeding input end 12 that are disposed opposite to each other and includes a cavity located between the horn opening end 11 and the horn feeding input end 12, where the cavity includes a first inner surface 13; and the transmission line 30 includes a straight portion 31 and a bent portion 32, where the grounding portion 40 is laid at two sides of the straight

portion 31, the straight portion 31, the bent portion 32, and the grounding portion 40 extend into the cavity through the horn feeding input end 12, the straight portion 31 is attached to the first inner surface 13, and a particular angle is formed between the bent portion 32 and the first inner surface 13. A transmission structure for sending a signal to an antenna can be simplified and a transmission distance can be shortened, so that a free space loss is reduced in a transmission process. In addition, a transmission line and a horn antenna with a high gain are coplanar, and integration of the horn antenna on a circuit board is facilitated.

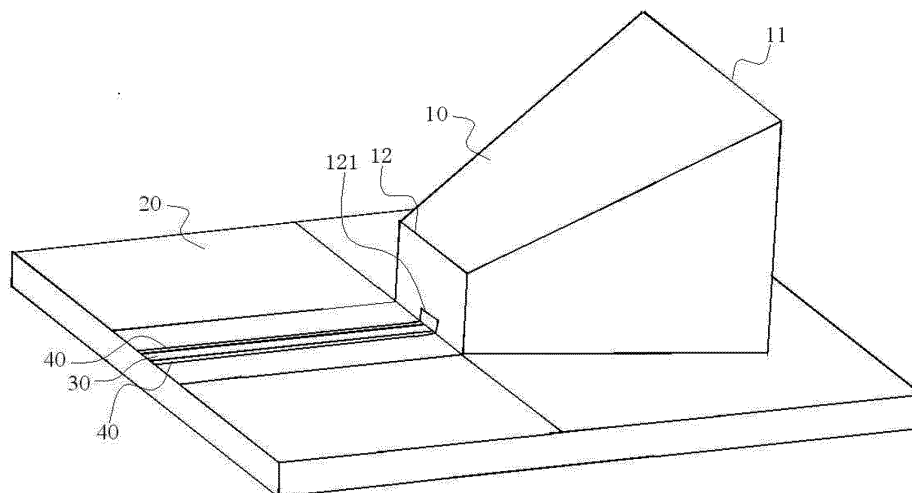

FIG. 1

EP 3 121 900 A1

Description

TECHNICAL FIELD

[0001] The present invention relates to the field of antenna technologies, and in particular, to a feeding apparatus.

BACKGROUND

[0002] With development of wireless communications technologies, bandwidth of microwave frequency bands cannot satisfy requirements. Therefore, developers begin to pay attention to an electromagnetic wave having a higher frequency band such as a millimetric wave. A free space loss is in direct proportion to a square of a radio-frequency frequency in a transmission process. For example, when a frequency is higher than 100 GHz, a free space loss caused by using an electromagnetic wave having a high frequency band such as a millimetric wave is above 40 dB. Output power of a device using an electromagnetic wave having a high frequency band such as a millimetric wave is relatively low. Therefore, an antenna with a higher gain needs to be designed to compensate the caused free space loss, so as to ensure normal communication.

SUMMARY

[0003] Embodiments of the present invention provide a feeding apparatus, which can reduce a transmission loss and ensure an antenna gain.

[0004] To resolve the foregoing technical problems, a first aspect of the present invention provides a feeding apparatus, which may include a horn antenna, a dielectric substrate, and a transmission line 30 and a grounding portion 40 that are disposed on the dielectric substrate, where

the horn antenna 10 includes a horn opening end 11 and a horn feeding input end 12 that are disposed opposite to each other and includes a cavity located between the horn opening end 11 and the horn feeding input end 12, where the cavity includes a first inner surface 13; and the transmission line 30 includes a straight portion 31 and a bent portion 32, where the grounding portion 40 is laid at two sides of the straight portion 31, the straight portion 31, the bent portion 32, and the grounding portion 40 extend into the cavity through the horn feeding input end 12, the straight portion 31 is attached to the first inner surface 13, and a particular angle is formed between the bent portion 32 and the first inner surface 13.

[0005] Based on the first aspect, in a first feasible implementation manner of the first aspect, the horn feeding input end 12 is provided with a through hole 121, and the straight portion 31, the bent portion 32, and the grounding portion 40 extend into the cavity through the through hole 121.

[0006] Based on the first feasible implementation man-

ner of the first aspect, in a second feasible implementation manner of the first aspect, the through hole 121 is of a square, where a side length of the square ranges from 1/16 of a wavelength to 1/4 of the wavelength, and the wavelength is an wavelength of an electromagnetic wave.

[0007] Based on the first feasible implementation manner of the first aspect or the second feasible implementation manner of the first aspect, in a third feasible implementation manner of the first aspect, a covering portion 50 configured to cover the straight portion 31 and the grounding portion 40 is disposed on the first inner surface 13, where a passage is formed between the covering portion 50 and the first inner surface 13, and the passage includes a first opening end and a second opening end, where the first opening end is connected to the through hole 121, and the second opening end faces the bent portion 32.

[0008] Based on the third feasible implementation manner of the first aspect, in a fourth feasible implementation manner of the first aspect, the first opening end has a shape and size the same as those of the through hole 121.

[0009] Based on the third feasible implementation manner of the first aspect, in a fifth feasible implementation manner of the first aspect, a length of the passage is equal to a distance between the second opening end and the bent portion 32.

[0010] Based on the third feasible implementation manner of the first aspect, in a sixth feasible implementation manner of the first aspect, a length of the passage ranges from 1/8 of the wavelength to 1/5 of the wavelength, and the wavelength is the wavelength of the electromagnetic wave.

[0011] Based on the first aspect, the first feasible implementation manner of the first aspect, the second feasible implementation manner of the first aspect, the third feasible implementation manner of the first aspect, the fourth feasible implementation manner of the first aspect, the fifth feasible implementation manner of the first aspect, or the sixth feasible implementation manner of the first aspect, in a seventh feasible implementation manner of the first aspect, the particular angle is 90 degrees.

[0012] Based on the first aspect, the first feasible implementation manner of the first aspect, the second feasible implementation manner of the first aspect, the third feasible implementation manner of the first aspect, the fourth feasible implementation manner of the first aspect, the fifth feasible implementation manner of the first aspect, or the sixth feasible implementation manner of the first aspect, in an eighth feasible implementation manner of the first aspect, a distance between the through hole 121 and the bent portion 32 is 1/4 of the wavelength, and the wavelength is the wavelength of the electromagnetic wave.

[0013] Based on the first aspect, the first feasible implementation manner of the first aspect, the second feasible implementation manner of the first aspect, the third

feasible implementation manner of the first aspect, the fourth feasible implementation manner of the first aspect, the fifth feasible implementation manner of the first aspect, or the sixth feasible implementation manner of the first aspect, in a ninth feasible implementation manner of the first aspect, a height of the bent portion 32 is 1/4 of the wavelength.

[0014] It can be known from the foregoing descriptions that a straight portion, a grounding portion, and a bent portion of a transmission line directly extend into a cavity of a horn antenna through a horn feeding input end of the horn antenna, the straight portion is attached to a first inner surface of the horn antenna, the bent portion is used as a feeding probe, and a particular angle is formed between the bent portion and the first inner surface of the cavity, so as to directly couple energy into the horn antenna. A transmission structure for sending a signal to the antenna is simplified and a transmission distance is shortened, so that a free space loss is reduced in a transmission process. In addition, the transmission line and the horn antenna with a high gain are coplanar, and integration of the horn antenna on a circuit board is facilitated.

BRIEF DESCRIPTION OF DRAWINGS

[0015] To describe the technical solutions in the embodiments of the present invention or in the prior art more clearly, the following briefly describes the accompanying drawings required for describing the embodiments. Apparently, the accompanying drawings in the following description show merely some embodiments of the present invention, and a person of ordinary skill in the art may still derive other drawings from these accompanying drawings without creative efforts.

FIG. 1 is a schematic diagram of a view of a feeding apparatus according to an embodiment of the present invention;

FIG. 2 is a schematic diagram of another view of a feeding apparatus according to an embodiment of the present invention; and

FIG. 3 is a schematic diagram of a covering portion 50 according to an embodiment of the present invention.

DESCRIPTION OF EMBODIMENTS

[0016] The following clearly and completely describes the technical solutions in the embodiments of the present invention with reference to the accompanying drawings in the embodiments of the present invention. Apparently, the described embodiments are merely some but not all of the embodiments of the present invention. All other embodiments obtained by a person of ordinary skill in the art based on the embodiments of the present invention without creative efforts shall fall within the protection scope of the present invention.

[0017] Referring to FIG. 1 and FIG. 2, FIG. 1 and FIG. 2 show a feeding apparatus according to an embodiment of the present invention. The feeding apparatus includes a horn antenna 10, a dielectric substrate 20, and a transmission line 30 and a grounding portion 40 that are disposed on the dielectric substrate 20.

[0018] The horn antenna 10 includes a horn opening end 11 and a horn feeding input end 12 that are disposed opposite to each other and includes a cavity located between the horn opening end 11 and the horn feeding input end 12, where the cavity includes a first inner surface 13.

[0019] The horn antenna 10 is a microwave antenna having a gradient wide waveguide opening plane and a round or rectangular section, and generally includes: a conical horn, an E-plane sectoral horn, an H-plane sectoral horn, and a pyramidal horn. The horn feeding input end 12 is an end having a relatively small opening, and the horn opening end 11 is an end having a relatively large opening. This embodiment of the present invention mainly uses a pyramidal horn antenna as an example to implement coplanarity of one surface of the pyramidal horn antenna (the surface is the first inner surface 13) and the dielectric substrate 20. When the antenna works in a main mode, an aperture field is in a cosine descending distribution on an H-plane and in a uniform distribution on an E-plane. Therefore, when an aperture phase difference of the pyramidal horn between the H-plane and the E-plane satisfies $SH=3/8$, $SE=1/4$, that is, when corresponding $\Phi_{M,H}=3\pi/4$ and $\Phi_{M,E}=\pi/2$, a maximum far-field gain value can be obtained.

[0020] In an implementation manner of the present invention, using a coplanar waveguide as an example, the transmission line 30 is a central conductor strip disposed on one surface of the dielectric substrate of the coplanar waveguide, and the grounding portion 40 is disposed at two sides of the central conductor strip. Compared with a normal microstrip transmission line, the coplanar waveguide has advantages that manufacture is simple and it is easy to implement a serial connection and a parallel connection (there is no need to perforate on a substrate) of a passive or active device in a circuit and easy to improve a circuit density.

[0021] The transmission line 30 includes a straight portion 31 and a bent portion 32, where the grounding portion 40 is laid at two sides of the straight portion 31, the straight portion 31, the bent portion 32, and the grounding portion 40 extend into the cavity through the horn feeding input end 12, the straight portion 31 is attached to the first inner surface 13, and a particular angle is formed between the bent portion 32 and the first inner surface 13.

[0022] Specifically, the bent portion 32 is a bent part of the transmission line 30 after the transmission line 30 extends into the cavity for a given distance, a function of which is to form a feeding structure of a probe. The particular angle formed by the bent portion 32, that is, the probe, and the first inner surface 13 is generally 90 degrees, that is, the bent portion 32 is perpendicular to the

first inner surface 13 (an unavoidable error may occur during a manufacturing process, and the error needs to be within an acceptable range so that an overall effect is not affected). A signal and energy transmitted by the straight portion 31 are directly fed to the horn antenna 10 by using the probe, which simplifies a signal transmission structure and shortens a transmission distance, thereby reducing a transmission loss.

[0023] Specifically, the horn feeding input end 12 is provided with a through hole 121, and the straight portion 31 and the bent portion 32 of the transmission line 30 and the grounding portion 40 extend into the cavity through the through hole 121. Preferably, the through hole 121 is of a square, and a side length of the square ranges from 1/16 of a wavelength to 1/4 of the wavelength. When the through hole 121 is set to square, higher bandwidth is obtained, and the square through hole facilitates an operation during processing, and may have a more precise size. It should be noted that, it should be avoided as far as possible to design the side length of the square to 1/8 of the wavelength within the range, because when the length is exactly 1/8 of the wavelength, an impedance matching status of an input port obviously deteriorates.

[0024] Certainly, in other implementation manners, the through hole 121 may be round.

[0025] During a practical design process, lengths of the straight portion 31 and the grounding portion 40 in the cavity matches a length of the bent portion 32 (that is, a size of the probe). In an implementation manner, a distance between the through hole 121 and the bent portion 32 is 1/4 of the wavelength, that is, the lengths of the straight portion 31 and the grounding portion 40 in the cavity are 1/4 of the wavelength. For example, when a frequency is 140 GHz, the distance between the through hole 121 and the bent portion 32 is 0.56 mm.

[0026] A height of the bent portion 32 (the probe) that is perpendicular to the first inner surface 13 and that performs feeding in the horn antenna 10 mainly affects a resonance frequency. A feeding end of the horn antenna 10 needs to match the probe. Therefore, not only the height of the probe affects the resonance frequency, but also a length of a reflection cavity (that is, the lengths of the straight portion 31 and the grounding portion 40 in the cavity) also affect impedance bandwidth. In an implementation manner, when the height of the bent portion 32 and the lengths of the straight portion 31 and the grounding portion 40 in the cavity are both 1/4 of the wavelength, good impedance bandwidth can be obtained. For example, when the frequency is 140 GHz, the height of the bent portion 32 is 0.56 mm.

[0027] Further, referring to FIG. 2 and FIG. 3, a covering portion 50 configured to cover the straight portion 31 and the grounding portion 40 is further disposed on the first inner surface 13, where a passage is formed between the covering portion 50 and the first inner surface 13, and the passage includes a first opening end and a second opening end, where the first opening end is connected

to the through hole 121, and the second opening end faces the bent portion 32.

[0028] It should be noted that the covering portion 50 covers parts of the straight portion 31 and the grounding portion 40 in the cavity, that is, the parts of the straight portion 31 and the grounding portion 40 in the cavity is located in the passage formed between the covering portion 50 and the first inner surface 13. In this embodiment, a length of the passage, that is, a covered length, may be set to be equal to a distance between the second opening end and the bent portion 32 (that is, a half of the lengths of the straight portion 31 and the grounding portion 40 in the cavity), or the length ranges from 1/8 of the wavelength to 1/5 of the wavelength.

[0029] The first opening end has a shape and size the same as those of the through hole 121, and the passage may be cylindrical, that is, the second opening end also has a shape and size the same as those of the first opening end or the through hole 121.

[0030] In an implementation manner, the covering portion 50 may be provided with a hollow portion that matches the covering portion 50 according to the shape and size of the through hole 121. For example, when the through hole 121 is of a square having a side length of 1/4 of the wavelength, a cross section of the hollow portion is of a square having a side length of 1/4 of the wavelength, and the length is equal to the length of the passage.

[0031] The covering portion 50 is added on the parts of the straight portion 31 and the grounding portion 40 in the cavity, a function of which is to widen the impedance bandwidth. After the horn antenna 10 uses a probe structure to perform feeding, the bandwidth is relatively narrow. Therefore, addition of the covering portion 50 can cause an additional resonant peak, and a status of matching between the additional resonant peak and an original resonant peak can be correspondingly adjusted by adjusting the length of the passage. The reflection cavity generally has a requirement of 1/4 of the wavelength (that is, the lengths of the straight portion 31 and the grounding portion 40 in the cavity), and an impedance matching bandwidth characteristic is relatively good when the length of the passage is within a particular range less than 1/4 of the wavelength. Therefore, the range may be set to 1/8 of the wavelength to 1/5 of the wavelength.

[0032] It should be noted that the wavelengths involved above are all a wavelength of an electromagnetic wave, where a propagation speed of the electromagnetic wave is equal to a speed of light c (3×10^8 m/s), that is, a product of the wavelength and a frequency f .

[0033] It can be known from the foregoing descriptions that a straight portion, a grounding portion, and a bent portion of a transmission line directly extend into a cavity of a horn antenna through a horn feeding input end of the horn antenna, the straight portion is attached to a first inner surface of the horn antenna, the bent portion is used as a feeding probe, and a particular angle is formed between the bent portion and the first inner surface of

the cavity, so as to directly couple energy to the horn antenna. A transmission structure for sending a signal to the antenna is simplified and a transmission distance is shortened, so that a free space loss is reduced in a transmission process. In addition, the transmission line and the horn antenna with a high gain are coplanar, and integration of the horn antenna on a circuit board is facilitated.

[0034] With descriptions of the foregoing embodiments, a person skilled in the art may clearly understand that the present invention may be implemented by hardware, firmware or a combination thereof. When the present invention is implemented by software, the foregoing functions may be stored in a computer-readable medium or transmitted as one or more instructions or code in the computer-readable medium. The computer-readable medium includes a computer storage medium and a communications medium, where the communications medium includes any medium that enables a computer program to be transmitted from one place to another. The storage medium may be any available medium accessible to a computer. The following provides an example but does not impose a limitation: The computer-readable medium may include a RAM, a ROM, an EEPROM, a CD-ROM, or another optical disc storage or disk storage medium, or another magnetic storage device, or any other medium that can carry or store expected program code in a form of an instruction or a data structure and can be accessed by a computer. In addition, any connection may be appropriately defined as a computer-readable medium. For example, if software is transmitted from a website, a server or another remote source by using a coaxial cable, an optical fiber/cable, a twisted pair, a digital subscriber line (DSL) or wireless technologies such as infrared ray, radio and microwave, the coaxial cable, optical fiber/cable, twisted pair, DSL or wireless technologies such as infrared ray, radio and microwave are included in a definition of a medium to which they belong. For example, a disk (Disk) and disc (disc) used by the present invention includes a compact disc (CD), a laser disc, an optical disc, a digital versatile disc (DVD), a floppy disk and a Blu-ray disc, where the disk generally copies data by a magnetic means, and the disc copies data optically by a laser means. The foregoing combination should also be included in the protection scope of the computer-readable medium.

[0035] What is disclosed above is merely exemplary embodiments of the present invention, and certainly is not intended to limit the protection scope of the present invention. Therefore, equivalent variations made in accordance with the claims of the present invention shall fall within the scope of the present invention.

Claims

1. A feeding apparatus, comprising a horn antenna 10, a dielectric substrate 20, and a transmission line 30

and a grounding portion 40 that are disposed on the dielectric substrate 20, wherein the horn antenna 10 comprises a horn opening end 11 and a horn feeding input end 12 that are disposed opposite to each other and comprises a cavity located between the horn opening end 11 and the horn feeding input end 12, wherein the cavity comprises a first inner surface 13; and the transmission line 30 comprises a straight portion 31 and a bent portion 32, wherein the grounding portion 40 is laid at two sides of the straight portion 31, the straight portion 31, the bent portion 32, and the grounding portion 40 extend into the cavity through the horn feeding input end 12, the straight portion 31 is attached to the first inner surface 13, and a particular angle is formed between the bent portion 32 and the first inner surface 13.

2. The feeding apparatus according to claim 1, wherein the horn feeding input end 12 is provided with a through hole 121, and the straight portion 31, the bent portion 32, and the grounding portion 40 extend into the cavity through the through hole 121.
3. The feeding apparatus according to claim 2, wherein the through hole 121 is of a square, wherein a side length of the square ranges from 1/16 of a wavelength to 1/4 of the wavelength, and the wavelength is a wavelength of an electromagnetic wave.
4. The feeding apparatus according to claim 2 or 3, wherein a covering portion 50 configured to cover the straight portion 31 and the grounding portion 40 is disposed on the first inner surface 13, a passage is formed between the covering portion 50 and the first inner surface 13, and the passage comprises a first opening end and a second opening end, wherein the first opening end is connected to the through hole 121, and the second opening end faces the bent portion 32.
5. The feeding apparatus according to claim 4, wherein the first opening end has a shape and size the same as those of the through hole 121.
6. The feeding apparatus according to claim 4, wherein a length of the passage is equal to a distance between the second opening end and the bent portion 32.
7. The feeding apparatus according to claim 4, wherein a length of the passage ranges from 1/8 of the wavelength to 1/5 of the wavelength, and the wavelength is the wavelength of the electromagnetic wave.
8. The feeding apparatus according to any one of claims 1 to 7, wherein the particular angle is 90 degrees.

9. The feeding apparatus according to any one of claims 1 to 7, wherein a distance between the through hole 121 and the bent portion 32 is $1/4$ of the wavelength.

5

10. The feeding apparatus according to any one of claims 1 to 7, wherein a height of the bent portion 32 is $1/4$ of the wavelength, and the wavelength is the wavelength of the electromagnetic wave.

10

15

20

25

30

35

40

45

50

55

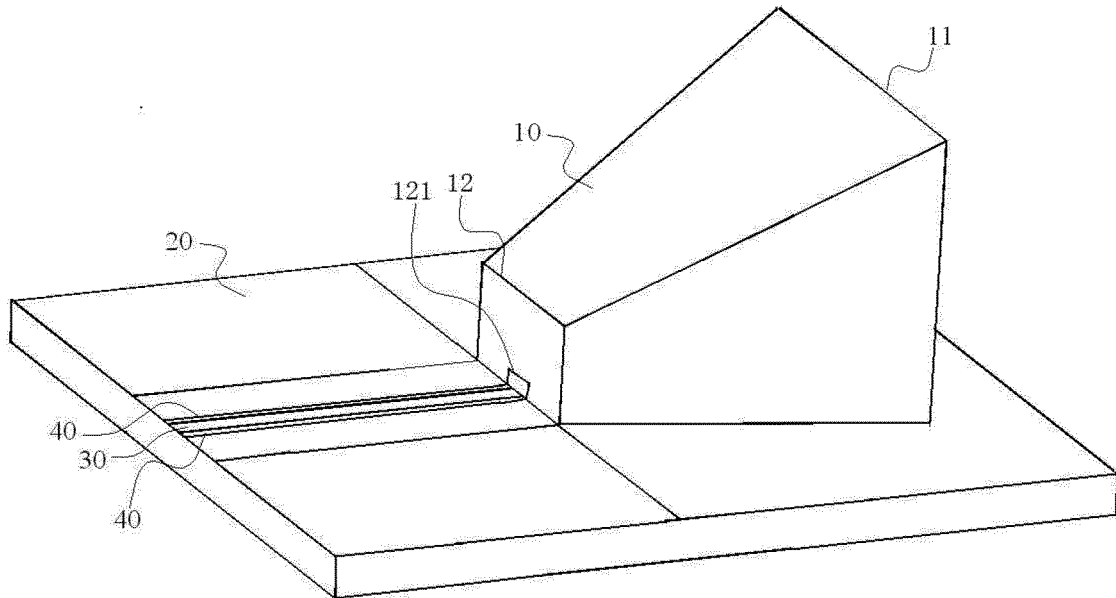

FIG. 1

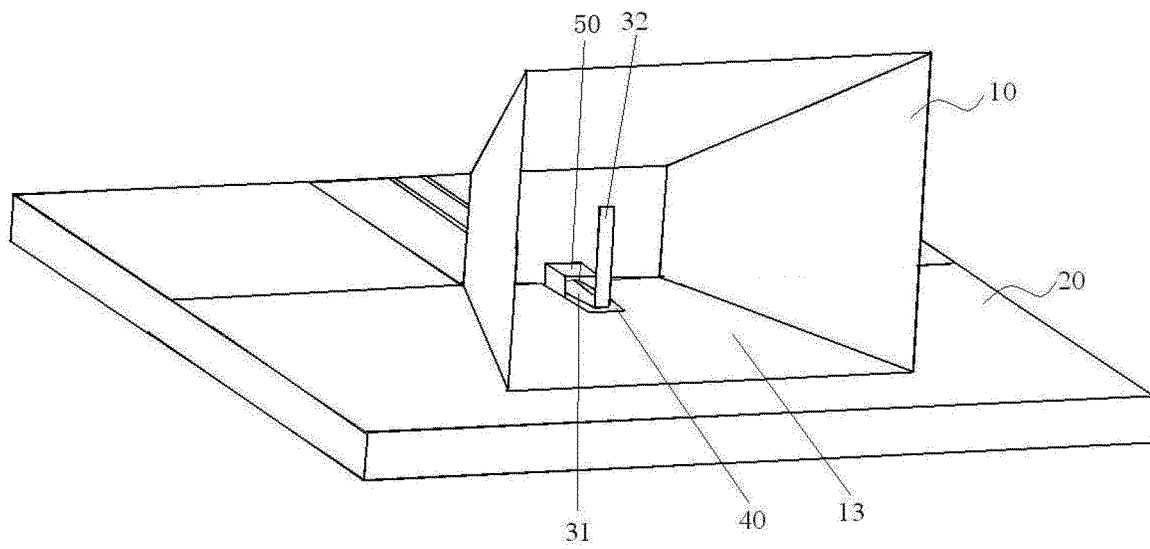

FIG. 2

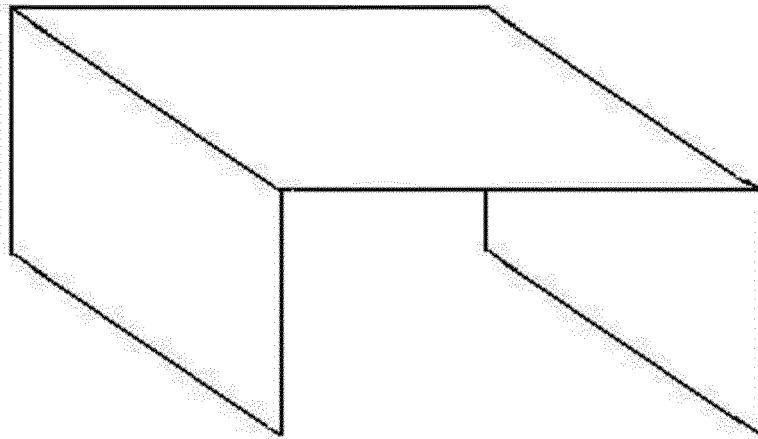

FIG. 3

INTERNATIONAL SEARCH REPORT

International application No.

PCT/CN2014/076655

| A. CLASSIFICATION OF SUBJECT MATTER | | |
|--|--|-----------------------|
| H01Q 13/02 (2006.01) i | | |
| According to International Patent Classification (IPC) or to both national classification and IPC | | |
| B. FIELDS SEARCHED | | |
| Minimum documentation searched (classification system followed by classification symbols) | | |
| H01Q | | |
| Documentation searched other than minimum documentation to the extent that such documents are included in the fields searched | | |
| Electronic data base consulted during the international search (name of data base and, where practicable, search terms used) | | |
| CNABS, CNTXT, SIPOABS, DWPI: base plate, feeder, probe, high frequency, loss, horn, antenna, substrate, plate, feed, millimeter wave, gain | | |
| C. DOCUMENTS CONSIDERED TO BE RELEVANT | | |
| Category* | Citation of document, with indication, where appropriate, of the relevant passages | Relevant to claim No. |
| A | CN 1528031 A (NRDTECH CO., LTD. et al.), 08 September 2004 (08.09.2004), the whole document | 1-10 |
| A | CN 101593872 A (UNIVERSITY OF ELECTRONIC SCIENCE AND TECHNOLOGY OF CHINA), 02 December 2009 (02.12.2009), the whole document | 1-10 |
| A | CN 101667682 A (SOUTHEAST UNIVERSITY), 10 March 2010 (10.03.2010), the whole document | 1-10 |
| A | JP 2009296301 A (JAPAN RADIO CO., LTD.), 17 December 2009 (17.12.2009), the whole document | 1-10 |
| <input type="checkbox"/> Further documents are listed in the continuation of Box C. <input checked="" type="checkbox"/> See patent family annex. | | |
| * Special categories of cited documents: | "T" later document published after the international filing date or priority date and not in conflict with the application but cited to understand the principle or theory underlying the invention | |
| "A" document defining the general state of the art which is not considered to be of particular relevance | "X" document of particular relevance; the claimed invention cannot be considered novel or cannot be considered to involve an inventive step when the document is taken alone | |
| "E" earlier application or patent but published on or after the international filing date | "Y" document of particular relevance; the claimed invention cannot be considered to involve an inventive step when the document is combined with one or more other such documents, such combination being obvious to a person skilled in the art | |
| "L" document which may throw doubts on priority claim(s) or which is cited to establish the publication date of another citation or other special reason (as specified) | "&" document member of the same patent family | |
| "O" document referring to an oral disclosure, use, exhibition or other means | | |
| "P" document published prior to the international filing date but later than the priority date claimed | | |
| Date of the actual completion of the international search 23 January 2015 (23.01.2015) | Date of mailing of the international search report 06 February 2015 (06.02.2015) | |
| Name and mailing address of the ISA/CN: State Intellectual Property Office of the P. R. China No. 6, Xitucheng Road, Jimenqiao Haidian District, Beijing 100088, China Facsimile No.: (86-10) 62019451 | Authorized officer LEI, Yunshan Telephone No.: (86-10) 62411508 | |

Form PCT/ISA/210 (second sheet) (July 2009)

INTERNATIONAL SEARCH REPORT
Information on patent family members

International application No.

PCT/CN2014/076655

| Patent Documents referred in the Report | Publication Date | Patent Family | Publication Date |
|---|-------------------|------------------|-------------------|
| CN 1528031 A | 08 September 2004 | WO 02067378 A1 | 29 August 2002 |
| | | KR 2001004425 A | 05 June 2001 |
| | | AU 2002230252 A1 | 04 September 2002 |
| | | KR 357283 B | 18 October 2002 |
| CN 101593872 A | 02 December 2009 | CN 101593872 B | 12 September 2012 |
| CN 101667682 A | 10 March 2010 | None | |
| JP 2009296301 A | 17 December 2009 | None | |

Form PCT/ISA/210 (patent family annex) (July 2009)