

(19)



(11)

EP 1 787 721 B1

(12)

EUROPEAN PATENT SPECIFICATION

(45) Date of publication and mention of the grant of the patent:
24.03.2010 Bulletin 2010/12

(51) Int Cl.:
B01L 3/00 (2006.01) B65D 51/14 (2006.01)
B65D 51/16 (2006.01)

(21) Application number: **05460032.5**

(22) Date of filing: **18.11.2005**

(54) **Cover for vessel with large opening**

Deckel für Behälter mit grosser Öffnung

Couvercle pour un recipient avec une grande ouverture

(84) Designated Contracting States:
AT BE BG CH CY CZ DE DK EE ES FI FR GB GR HU IE IS IT LI LT LU LV MC NL PL PT RO SE SI SK TR

(43) Date of publication of application:
23.05.2007 Bulletin 2007/21

(73) Proprietor: **Przedsiębiorstwo Produkcyjno Handlowo Usługowe Tomasz Kwapisz 93-373 Lodz (PL)**

(72) Inventor: **Kwapisz, Tomasz 93-373 Lodz (PL)**

(74) Representative: **Dziubinska, Jolanta Kancelaria Patentowa al. Kard. Wyszyńskiego 58 m 25 94-047 Lodz (PL)**

(56) References cited:
DE-A1- 3 343 055 US-A- 4 545 498
US-A- 4 713 219

EP 1 787 721 B1

Note: Within nine months of the publication of the mention of the grant of the European patent in the European Patent Bulletin, any person may give notice to the European Patent Office of opposition to that patent, in accordance with the Implementing Regulations. Notice of opposition shall not be deemed to have been filed until the opposition fee has been paid. (Art. 99(1) European Patent Convention).

Description

[0001] The object of this invention is a cover for a vessel with large opening, designed to close vessels like glass balloons or jars, in which fermentation process can be conducted or various products can be stored.

[0002] There are known various kinds of covers designed to close glass balloons or jars with large opening. These covers are in the shape of large cork stoppers or hoods which are put upon vessel opening with gentle curves formed in the process of glass product manufacture. The covers are made from rubber or polyethylene. They have gently curved inside edges, contacting the vessel border at the right angle without sealing the surface of contact. In order to improve the efficiency of closing, additional seals are applied in the form of rings, protrusions, and bendings.

[0003] To the known covers for vessels with large openings fermentation tubes cannot be applied in a simple manner, thus making it difficult to safely proceed with fermentation process of the mass contained in the vessel; and it is also difficult to add any additional substances or take samples for testing through the hole in the cover.

[0004] Therefore, the aim of the present invention is to provide a cover for the vessel with large opening that would enable storing products or carrying out the processes inside the vessel.

[0005] This object is obtained by the cover claimed in claim 1.

Preferred embodiments are defined in the dependent claims.

[0006] According to this invention, on its circumference the cover for a vessel with large opening has a ring with an edge profiled inside and a lip situated at the end of the vertical internal surface of the ring; and it has at least one hole on the cover surface situated at any height; and on its external side it has a flange with an optional hole, with optional strengthening ribs and/or other strengthening elements of any shape on the surface of vessel closing.

[0007] The cover has a hole on its surface situated preferably in the axis or outside the axis, where the hole is in the form of a short stub pipe of any height.

[0008] According to this invention, the cover surface closing the vessel opening is in a flat, concave or convex form.

[0009] The cover has optionally a hole in its surface, closed optionally at one and/or both sides, as well as a ring with an internal wall at the angle from -90° to $+90^\circ$ to its upper surface.

[0010] In the solution offered by this invention the profiled internal surface of the ring and the lip situated in the lower part of the ring and fitting into the recess on the vessel under its flange result in the tight closing of the vessel.

[0011] The profiled internal surface and the edge of the ring create tight contact with the side surface of the vessel, thus tight closing the vessel. The internally pro-

filed surface of the edge is optionally chamfered at an angle or stepped. After putting the cover on the vessel opening, the lip situated on the internal surface of the lower part of the ring fills the cavity under the edge of the vessel opening, which results in the tightening of the cover. The said lip acts as an O-ring, thus sealing the vessel opening and preventing the cover from sliding off the vessel; and the profiled bending, situated inside, on the external circumference of the ring, creates tight contact with the vessel edge, making it sealed.

[0012] The surface that closes the vessel opening, upon which a hole is optionally situated, is flat, concave or convex. The shape of this surface does not affect the tightness of the cover according to this invention.

[0013] In the solution offered by this invention, on the cover surface there is optionally a hole and/or a small stub pipe, closed at one or both sides by a thin, easily removable plastic layer. In this hole a fermentation tube may be optionally inserted, which enables the sealing of the vessel and the conducting of fermentation process directly in this vessel. On the cover surface there may be optionally a strengthening in the form of ribs, situated on one or both sides. The ribs strengthen the surface of the cover, especially when additional equipment is to be put into the holes. The number and length of the ribs is to be adjusted to the needs.

[0014] The hole in the shape of a stub pipe with the height exceeding the thickness of the layer of the closing surface enables the fastening of a fermentation tube in a vertical position. The flange of the cover, situated on its edge and protruding outside the cover contour, is of any shape and width; and it has optionally a holder of any shape. On the flange there is optionally a hole or recess of any shape, or several holes of any shapes. On the flange holders there are optionally recesses made in plastic and facilitating the holding of the cover during its putting on or off. On the cover surface there may optionally be made various inscriptions.

[0015] According to this invention, the cover may have any external shape, offering solutions that enable its tight contact with the hole surface, its easy putting on and off the vessel and insertion of a fermentation tube.

[0016] In an embodiment of the cover, on the surface closing the opening of the vessel there are optionally additional holes for placing or inserting additional equipment into the vessel. The hole situated on the surface closing the opening of the vessel may be positioned at a height selected according to the needs.

[0017] The solution according to this invention is shown in exemplary embodiments and Figures 1 to 9. Fig. 1 shows the cover viewed from above, while Fig. 1a shows the cross-section A-A of the cover. Fig. 2 shows the cover with a large flange viewed from below; Fig. 2a shows the cover viewed from above; Fig. 2b shows the cross-section A-A; and Fig. 2c shows the cross-section B-B. Fig. 3 shows the cover with flat surface viewed from below; Fig. 3a shows this cover viewed from above; Fig. 3b shows the cross-section A-A; and Fig. 3c shows the

cross-section B-B. Fig. 4 shows the cover with the surface closing the vessel situated in the lower part of the ring, viewed from below; Fig. 4a shows this cover viewed from above; Fig. 4b shows the cross-section A-A; and Fig. 4c shows the cross-section B-B. Fig. 5 shows the cover with internal surface above the flat surface of the ring, viewed from below; Fig. 5a shows this cover viewed from above; Fig. 5b shows the cross-section A-A; and Fig. 5c shows the cross-section B-B. Fig. 6 shows the cover with concave surface viewed from below; Fig. 6a shows this cover viewed from above; Fig. 6b shows the cross-section A-A; and Fig. 6c shows the cross-section B-B. Fig. 7 shows the cover with the hole situated outside the axis, viewed from below; Fig. 7a shows this cover viewed from above; Fig. 7b shows the cross-section A-A; and Fig. 7c shows the cross-section B-B. Fig. 8 shows the cover with the surface closing the vessel situated below the surface of the ring, viewed from below; Fig. 8a shows this cover viewed from above; Fig. 8b shows the cross-section A-A; and Fig. 8c shows the cross-section B-B. Fig. 9 shows the cover with the surface without any strengthening viewed from below; Fig. 9a shows this cover viewed from above; Fig. 9b shows the cross-section A-A; and Fig. 9c shows the cross-section B-B.

Example 1

[0018] The cover is made from flexible plastic, preferably "Multiflex", in the form of a profiled, flat closure with a ring (2) protruding above the flat surface and a flange (8) outside. The ring has an edge (3) inside, on its circumference with greater diameter, which has been formed at an angle in the shape of a gentle curve. In the lower part of the ring there is a lip (5). In the cover axis there is a hole (4) in the form of a short stub pipe covered at one side by a thin layer (9). On the external flange (8) there is a hole (11) and a holder (6) with a recess (6a) on its surface.

Example 2

[0019] The cover as in example 1 has a hole (4) in the form of a short stub pipe with a closure in the form of a thin layer of plastic (9), and a flange (8) with two holders in the shape of elongations (6) and (6a), where one holder has an opening (11) and the other has a recess (6a). The closure (9) of the hole (4) is to be removed before introducing a fermentation tube. On the flat surface (1) there are ribs (7) stiffening the closing surface of the cover.

Example 3

[0020] The cover as in example 1 has two holes (4) in the form of a short stub pipe (7), one destined for fastening a fermentation tube and the other for applying additional equipment.

Example 4

[0021] The cover as in example 2 has a hole (4) situated outside cover axis.

Example 5

[0022] The cover made of plastic has a ring (2) with a lip (5) and an edge (3) formed inside on its external circumference. The ring surface (1) passes into a flat surface, where the hole (4) and ribs (7) are situated (Fig. 3).

Example 6

[0023] The cover made of plastic has a ring (2) with a formed internal edge (3), a lip (5), and a surface (1) formed on the bending of the internal vertical wall of the ring (2), thus making a cover with a surface (10) at the height of a flange (8) situated outside the ring (2) (Fig. 4)

Example 7

[0024] The cover as in example 1 has a surface (1) formed above the surface of the ring (2) with a hole (4) protruding above this surface (Fig. 5).

Example 8

[0025] The cover as in example 1 has a ring (2) passing into a concave surface (Fig. 6).

Claims

1. A cover for a vessel with a large opening in the form of a short cylinder, closed on one side by a surface, wherein on its circumference it has a ring (2) with an edge profiled inside (3) and a lip (5) situated at the end of the internal vertical part of the ring surface, and at least one hole (4) on the cover surface (1), and a flange (8) extending circumferentially outside the ring and bearing a hole (11); and the surface (1) may have strengthening ribs (7) and/or other strengthening elements.
2. Cover according to claim 1, the cover **characterized by** the fact that the hole (4) in the shape of a stub pipe of any height is situated in the cover axis or outside the axis.
3. Cover according to claim 1, the cover **characterized by** the fact that the surface (1) closing the vessel opening is flat, concave or convex.
4. Cover according to claim 1, the cover **characterized by** the fact that said hole (4) is covered on one and/or both sides by a thin layer (9).

5. Cover according to claim 1, the cover **characterized by** the fact that the ring (2) optionally has an internal wall (12) at an angle from -90° to $+90^\circ$ to its upper surface (13).

Patentansprüche

1. Kappe für Breitöffnungsbehälter in der Form einer kurzen Walze, der einseitig eine horizontale Ebene hat. Diese Kappe ist **dadurch** kennzeichnend, dass sie eine Form des profilierten flachen Verschlusses und im Querschnitt eine Form eines Kreises hat, der im äußeren Umfang einen Ring (2) und einen entfernbaren Verschluss (5) und in der vertikalen Achse eine Öffnung (4) in der flachen Oberfläche (1) hat, und dass der Flansch (8) dagegen mindestens eine Öffnung (11) hat, und dass die flache Oberfläche (1) eine Form eines kurzen Aufsatzes (7) haben kann, und/oder der Elemente verstärkt. 10
2. Kappe für Breitöffnungsbehälter ist gemäß der Bedingung Nr. 1 **dadurch** kennzeichnend, dass die Öffnung (4) von außen mit einer dünnen, entfernbaren Membrane gedeckt ist 25
3. Kappe für Breitöffnungsbehälter ist gemäß der Bedingung Nr. 1 **dadurch** kennzeichnend, dass die flache Oberfläche (1), die den Behälter verschließt, konkav oder konvex ist 30
4. Kappe für Breitöffnungsbehälter ist gemäß der Bedingung Nr. 1 **dadurch** kennzeichnend, dass die Öffnung (4) von einer und/oder zwei Seiten durch eine dünne Schicht (9) verdeckt ist 35
5. Kappe für Breitöffnungsbehälter ist gemäß der Bedingung Nr. 1 **dadurch** kennzeichnend, dass der Ring (2) optional eine Innenwand (12) unter dem Winkel von -90° bis $+90^\circ$ gegen seine obere Fläche (13) hat 40

Revendications

1. Le bouchon - couronne dans la forme du cylindre court fermé unilatéralement par la surface horizontale fermée se **caractérise par** cela qu'il est dans la forme de la fermeture plate profilée, ayant le profil du cercle qui possède sur le périmètre extérieur la bague (2), et la fermeture possible à éliminer (5) et il possède dans l'axe vertical l'orifice (4) sur la surface plate (1), le bride (8) possède au moins un orifice (11) et la surface plate (1) peut posséder la forme de la cheminée courte (7) et/ou les éléments de renforcement. 45
2. Le bouchon - couronne selon la réserve 1 se **carac-** 50

térise par cela que l'orifice (4) est protégé extérieurement par le film fin à enlever.

3. Le bouchon - couronne selon la réserve 1 se **caractérise par** cela que la surface plate (1) qui ferme le récipient est concave ou convexe. 5
4. Le bouchon - couronne selon la réserve 1 se **caractérise par** cela que l'orifice (4) est couvert d'un ou de deux côtés par la couche fine (9) 10
5. Le bouchon - couronne selon la réserve 1 se **caractérise par** cela que la bague (2) possède la paroi interne (12) sous l'angle de -90° à $+90^\circ$ par rapport à sa surface supérieure (13). 15

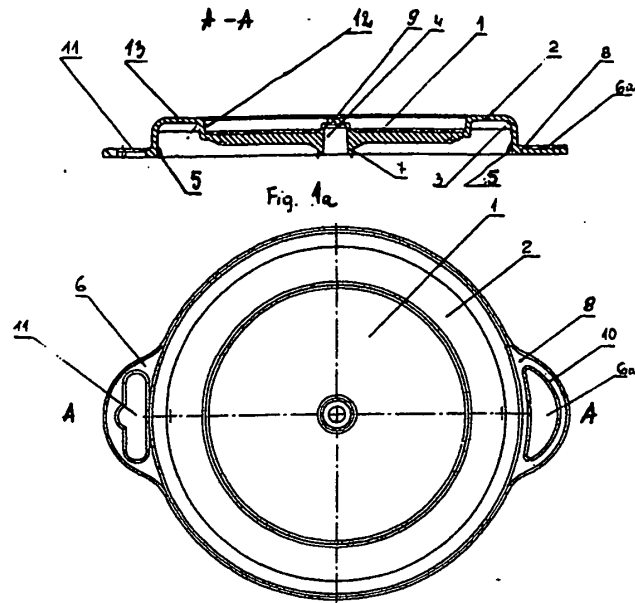

Fig. 1

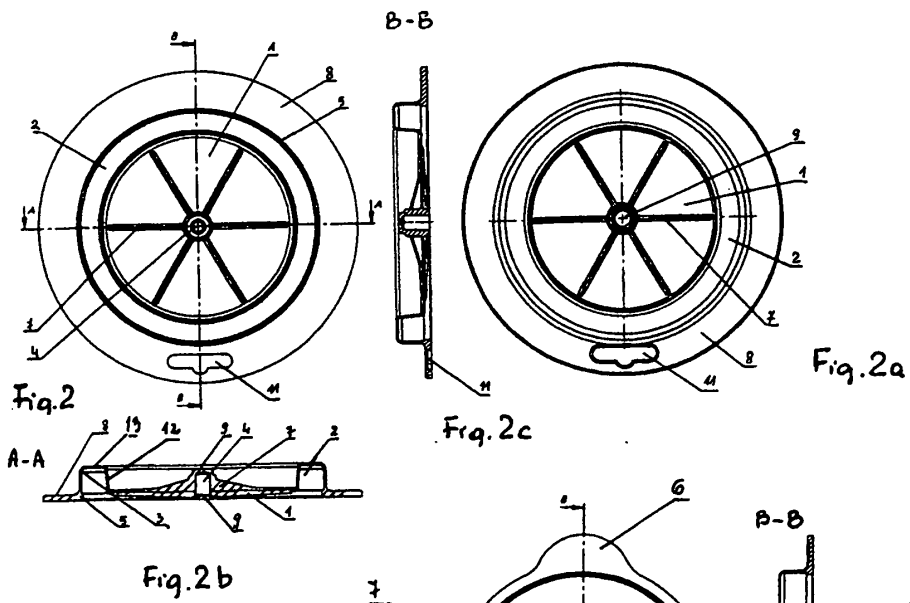

Fig. 2

Fig. 2c

Fig. 2a

Fig. 2b

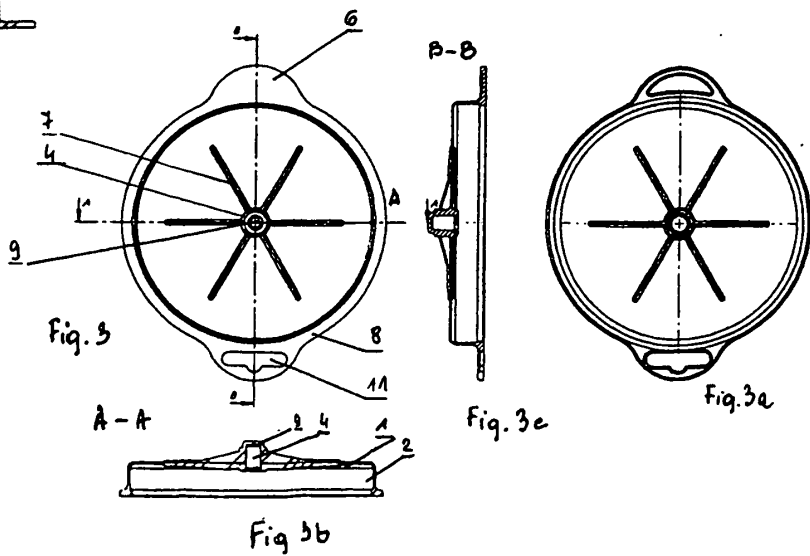

Fig. 3

Fig. 3c

Fig. 3a

Fig. 3b

