

K. H. LOOMIS.
VALVE FOR STEAM ENGINES.

No. 66,156.

Patented June 25, 1867.

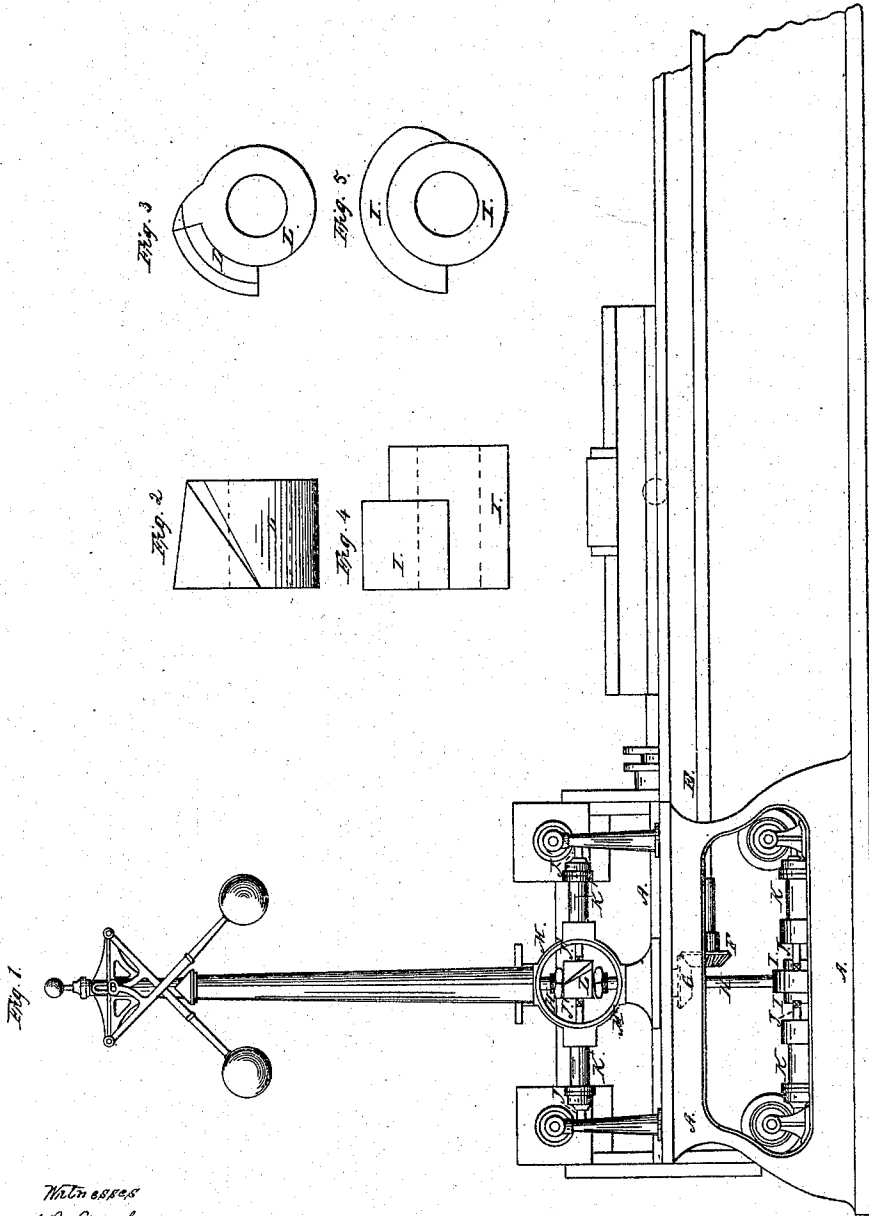

Witnesses
A. B. Strongham,
Edw. H. Penning

Inventor
Kellogg & Loomis

K. H. LOOMIS.
VALVE FOR STEAM ENGINES.

No. 66,156.

Patented June 25, 1867.

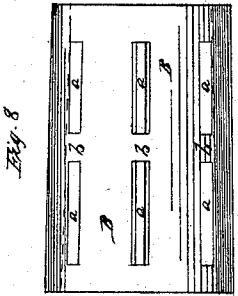
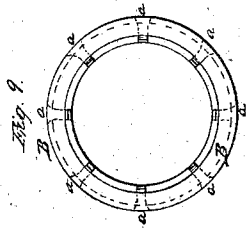
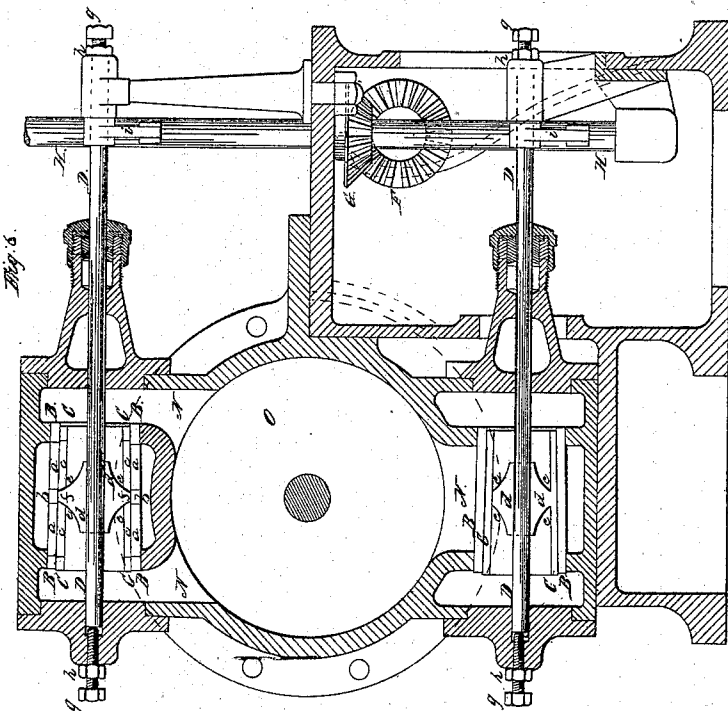
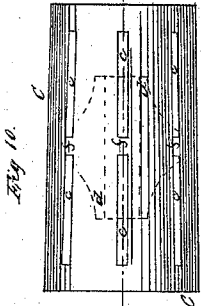
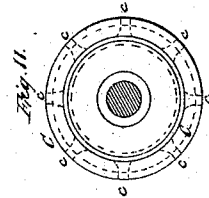
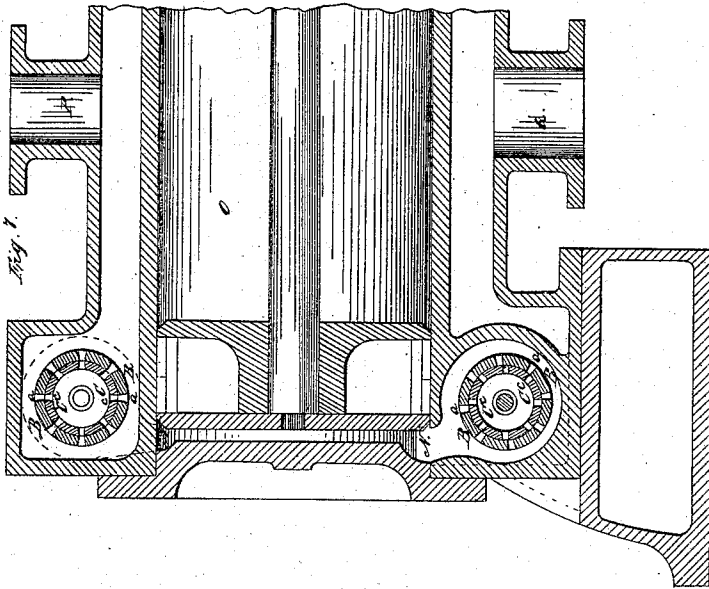

Witnesses
A. B. Stoughton,
Edw. T. Perry,

Inventor.
Kellogg & Loomis

United States Patent Office.

KELLOGG H. LOOMIS, OF CINCINNATI, OHIO, ASSIGNOR TO CORNELIUS
VAN BRUNT, OF FISHKILL, NEW YORK.

Letters Patent No. 66,156, dated June 25, 1867.

IMPROVEMENT IN VALVES OF STEAM ENGINES.

The Schedule referred to in these Letters Patent and making part of the same.

TO ALL WHOM IT MAY CONCERN:

Be it known that I, KELLOGG H. LOOMIS, of Cincinnati, in the county of Hamilton, and State of Ohio, have invented certain new and useful improvements in Steam Engines; and I do hereby declare the following to be a full, clear, and exact description of the construction and operation of the same, reference being had to the accompanying drawings, making a part of this specification, in which—

Figure 1 represents a side elevation.

Figures 2, 3, 4, and 5 represent, on an enlarged scale and in different positions, the cams for operating the valves.

Figure 6 represents a vertical transverse section through the cylinder and valves and accompanying parts.

Figure 7 represents a longitudinal vertical section through the cylinder, valves, and the adjacent parts; and

Figures 8, 9, 10, and 11 represent, on an enlarged scale, the conical plug-valves and their openings.

Similar letters of reference, where they occur in the several separate figures, denote like parts of the engine in all the drawings.

My invention consists, first, in the construction, and incidental thereto, the operation of the steam valves; and secondly, my invention consists in the construction and operation of the cams on the governor-shaft, and the appliances connected thereto, for operating the steam-valves.

To enable others skilled in the art to make and use my invention, I will proceed to describe the same with reference to the drawings.

A represents the frame or stand on which the engine rests. The steam-valves are arranged above and below the steam-cylinder, and in the line of their lengths at right angles relatively to each other, so that a section taken through the valves and cylinder will be a cross-section of one and a longitudinal section of the other. My valves are what I term conical plug-valves, as seen more distinctly in figs. 6, 8, and 10. They are constructed as follows: The case or seat B, in which the inner part C of the valve turns, is stationary, but made separate from the frame in which it is set, so that the openings through it may be more regularly and accurately made than it could be in the frame from the inaccessibility of the necessary tools to dress them out, and so that also they may be taken out and replaced by others should they become worn, or from any cause get out of order. The steam openings *a*, through the seat B, do not extend from end to end thereof, there being a portion, *b*, in the line of these openings, which remains to give the seat sufficient strength and prevent springing or yielding, as would be the case if cut clean through.

Within the case or seat B is the valve proper, C, made conical so as to snugly fit and readily turn inside of the seat. The valve or plug C is also furnished with a series of openings, *c*, cut through its perimeter, which correspond in shape and position with those, *a*, cut through the seat, and the plug or inner part C of the valve has a hub, *d*, inside of it, and a part of it of the general form shown in figs. 6 and 10, that is, of sufficient length at its centre to make a firm fastening and support on the valve-rod D that turns it, and cut away where it joins the interior of the plug, as seen at *e*, so as not to contract or interfere with the steam openings *c*. A portion also of the plug *f* is left uncut, so that it will not spring or yield at its central portion, which it would do to an injurious extent if the openings extended throughout its length as in ordinary cases, except a ring at the ends. There are set-screws *g* and jam-nuts *h* at each end of the valve-rod D, so that the plug C may be tightened or loosened in its seat when necessary.

The valves are operated as follows: Motion from the engine is imparted to the shaft E in any of the usual ways. This shaft E is horizontal, and has upon its end a bevel-gear, F, that takes into a similar gear, G, on the governor-shaft or rod H, and through this gearing the governor-shaft is revolved. Upon the lower end of the governor-shaft or rod there is secured a cam, I, which, as it turns with said rod, operates alternately the rods J J, said rods passing through cylinders or boxes K K in which springs (or an air-cushion) may be arranged to return said rods after they have been moved by the cam, or, in other words, to keep said rods up to the cam. The rods J J, after passing through the cylinders K, connect with an arm, respectively, *i*, on the valve-rods D, and thus oscillate said rods and the valves or plugs C upon them. The openings *a c* through the

seat and plug, it will be perceived, are rounded off or increased in area both where the steam enters and leaves them. This is done to allow the steam to enter and leave said openings without impediment, as is the case where the openings are uniform in area throughout. The escape-valves below the steam cylinder are worked with a uniform extent of rotation, varying, of course, in the time or speed of the rotation with the motion of the governor-shaft. It is not so, however, with the inlet-valves, as they act as inlet and cut-off valves both, so that their extent of rotation, as well as their speed, must be varied as the speed of the engine varies.

The inlet-valves, though constructed like the escape-valves, are operated as follows: Upon the governor-rod H, nearly at the line between the inlet-valves or chests, is arranged a cam, L, which is both conical and spiral, and which, as it is raised up by the action of the governor-balls in the usual way, is constantly presenting a different and shorter beat or throw to the pistons or rods J' J' that operate the inlet-valves, and causing them to open the steam ways for a correspondingly shorter and shorter period; and when this cam is lowering, by the motion of the governor-balls, an increased beat or throw is presented to the rods J' J', which hold open for an increased period of time the steam openings in the valves.

The rods, J' J' like those worked by the under cam, pass through cylinders or boxes K' K', wherein are springs, or an air-cushion, for returning or holding said rods against the cam L, and this cam is arranged within a ring that forms a support for the governor-shaft and the cylinders K' K'. The cam L revolves within the ring M, and should the governor from any cause raise the cam so high as to be above and not touch the rods J', the consequence would be that the valves would remain closed, and no injury could happen to the engine.

The steam passages N, to and from the cylinder O, are of the usual form and construction, P being the inlet steam pipe, and Q the escape pipe. The steam valves being close to the steam cylinder, and operated by the governor, without the intervention of any other valves, the change of speed of the governor is instantly imparted to the piston, as the steam has such a short distance to go after passing the valve.

Having thus fully described my invention, what I claim therein as new, and desire to secure by Letters Patent, is—

1. The case or seat B constructed as described, and arranged within a conical opening in its frame, and provided with a tapering plug-valve, C, said valve being provided with a transverse hub at its centre, and with longitudinal slots on each side of said hub, the steam openings being uniform at their intersection, but made flaring from this point outwards and inwards as specified, the whole being arranged as and for the purposes set forth.

2. The arrangement of the conical spiral cams L and I upon the vertical governor-shaft in combination with the tapering plug-valves J' J', for regulating the flow of steam to and from the cylinders, in the manner herein specified.

3. The valve-seat B, with central supports *b b* bearing upon the cones *f f*, when arranged in combination with the valve C, in the manner and for the purposes specified.

KELLOGG H. LOOMIS.

Witnesses:

A. B. STOUGHTON,
EDM. F. BROWN.