

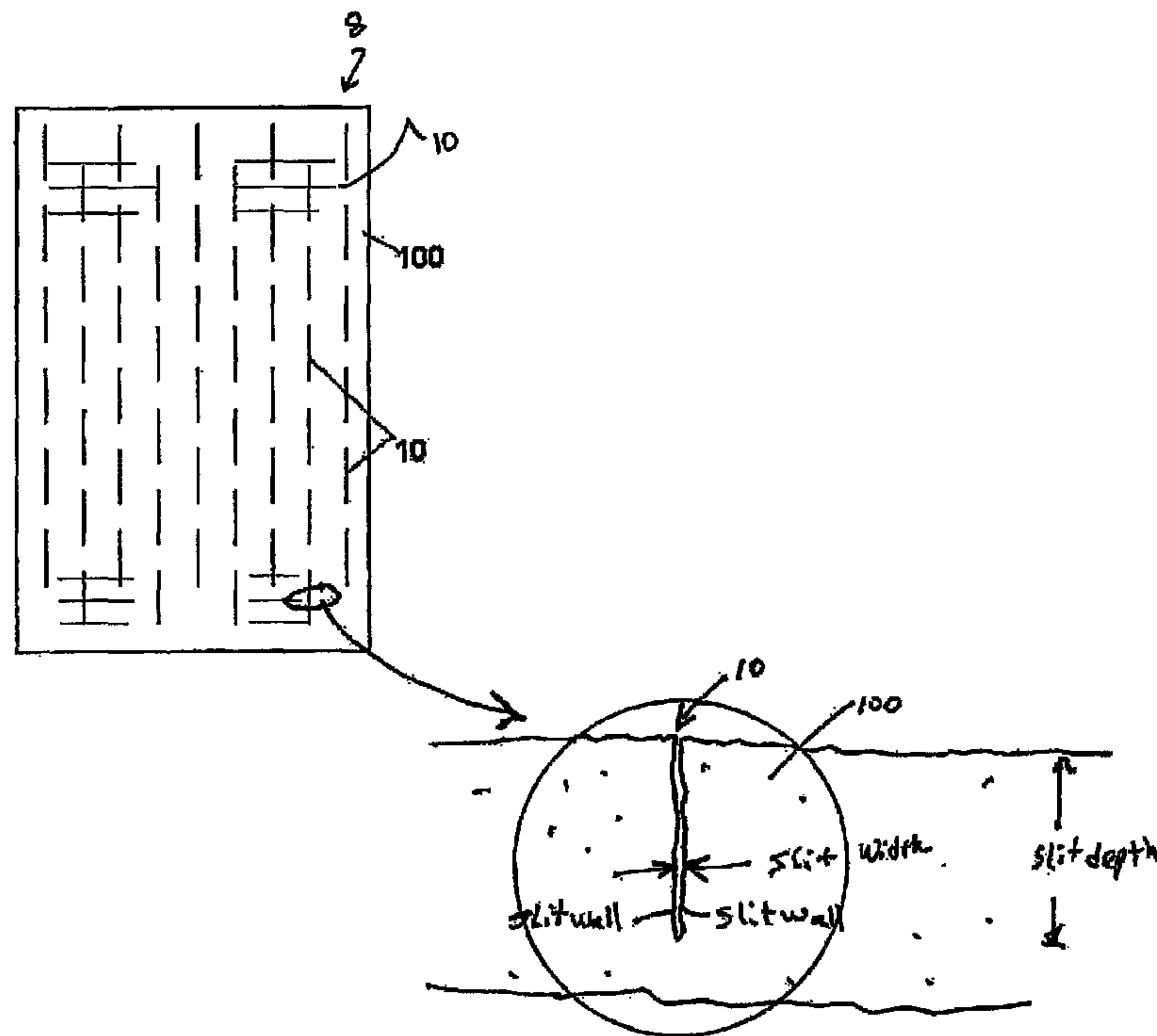

(86) Date de dépôt PCT/PCT Filing Date: 2008/06/12  
 (87) Date publication PCT/PCT Publication Date: 2009/04/16  
 (85) Entrée phase nationale/National Entry: 2009/12/10  
 (86) N° demande PCT/PCT Application No.: IB 2008/001517  
 (87) N° publication PCT/PCT Publication No.: 2009/047596  
 (30) Priorité/Priority: 2007/06/12 (US60/943,321)

(51) Cl.Int./Int.Cl. *A61F 13/15* (2006.01)  
 (71) Demandeur/Applicant:  
 DSG TECHNOLOGY HOLDINGS LTD., VG  
 (72) Inventeurs/Inventors:  
 WRIGHT, ANDREW, GB;  
 TSANG, PATRICK KING YU, HK  
 (74) Agent: OGILVY RENAULT LLP/S.E.N.C.R.L.,S.R.L.

(54) Titre : ARTICLE ABSORBANT AVEC AME ABSORBANTE FENDUE  
 (54) Title: ABSORBENT ARTICLE WITH A SLIT ABSORBENT CORE



**FIG. 2a**

(57) **Abrégé/Abstract:**

The invention relates to slit absorbent articles and the use of slits in absorbent materials to provide improved liquid intake rate, flexibility and softness compared to the unmodified material. The absorbent material, including superabsorbent materials, are particularly useful as absorbent cores in disposable absorbent articles such as diapers, incontinent products, sanitary napkins and the like.

(12) INTERNATIONAL APPLICATION PUBLISHED UNDER THE PATENT COOPERATION TREATY (PCT)

(19) World Intellectual Property Organization  
International Bureau(43) International Publication Date  
16 April 2009 (16.04.2009)

PCT

(10) International Publication Number  
**WO 2009/047596 A1**(51) International Patent Classification:  
A61F 13/15 (2006.01)(21) International Application Number:  
PCT/IB2008/001517

(22) International Filing Date: 12 June 2008 (12.06.2008)

(25) Filing Language: English

(26) Publication Language: English

(30) Priority Data:  
60/943,321 12 June 2007 (12.06.2007) US(71) Applicant (for all designated States except US): **DSG TECHNOLOGY HOLDINGS LTD.**; Craigmuir Chambers, P.O. Box 71, Road Town, Tortola (VG).

(72) Inventors; and

(75) Inventors/Applicants (for US only): **WRIGHT, Andrew** [GB/GB]; 5 Warren Close, Pilsley, Chesterfield, Derbyshire S45 8ES (GB). **TSANG, Patrick, King Yu** [GB/GB]; The Chase, Greenway Lane, Matlock, Derbyshire S45 8ES (GB).

(81) Designated States (unless otherwise indicated, for every kind of national protection available): AE, AG, AL, AM, AO, AT, AU, AZ, BA, BB, BG, BH, BR, BW, BY, BZ, CA, CH, CN, CO, CR, CU, CZ, DE, DK, DM, DO, DZ, EC, EE, EG, ES, FI, GB, GD, GE, GH, GM, GT, HN, HR, HU, ID, IL, IN, IS, JP, KE, KG, KM, KN, KP, KR, KZ, LA, LC, LK, LR, LS, LT, LU, LY, MA, MD, ME, MG, MK, MN, MW, MX, MY, MZ, NA, NG, NI, NO, NZ, OM, PG, PH, PL, PT, RO, RS, RU, SC, SD, SE, SG, SK, SL, SM, SV, SY, TJ, TM, TN, TR, TT, TZ, UA, UG, US, UZ, VC, VN, ZA, ZM, ZW.

(84) Designated States (unless otherwise indicated, for every kind of regional protection available): ARIPO (BW, GH, GM, KE, LS, MW, MZ, NA, SD, SL, SZ, TZ, UG, ZM, ZW), Eurasian (AM, AZ, BY, KG, KZ, MD, RU, TJ, TM), European (AT, BE, BG, CH, CY, CZ, DE, DK, EE, ES, FI, FR, GB, GR, HR, HU, IE, IS, IT, LT, LU, LV, MC, MT, NL, NO, PL, PT, RO, SE, SI, SK, TR), OAPI (BF, BJ, CF, CG, CI, CM, GA, GN, GQ, GW, ML, MR, NE, SN, TD, TG).

**Published:**

— with international search report

(54) Title: ABSORBENT ARTICLE WITH A SLIT ABSORBENT CORE

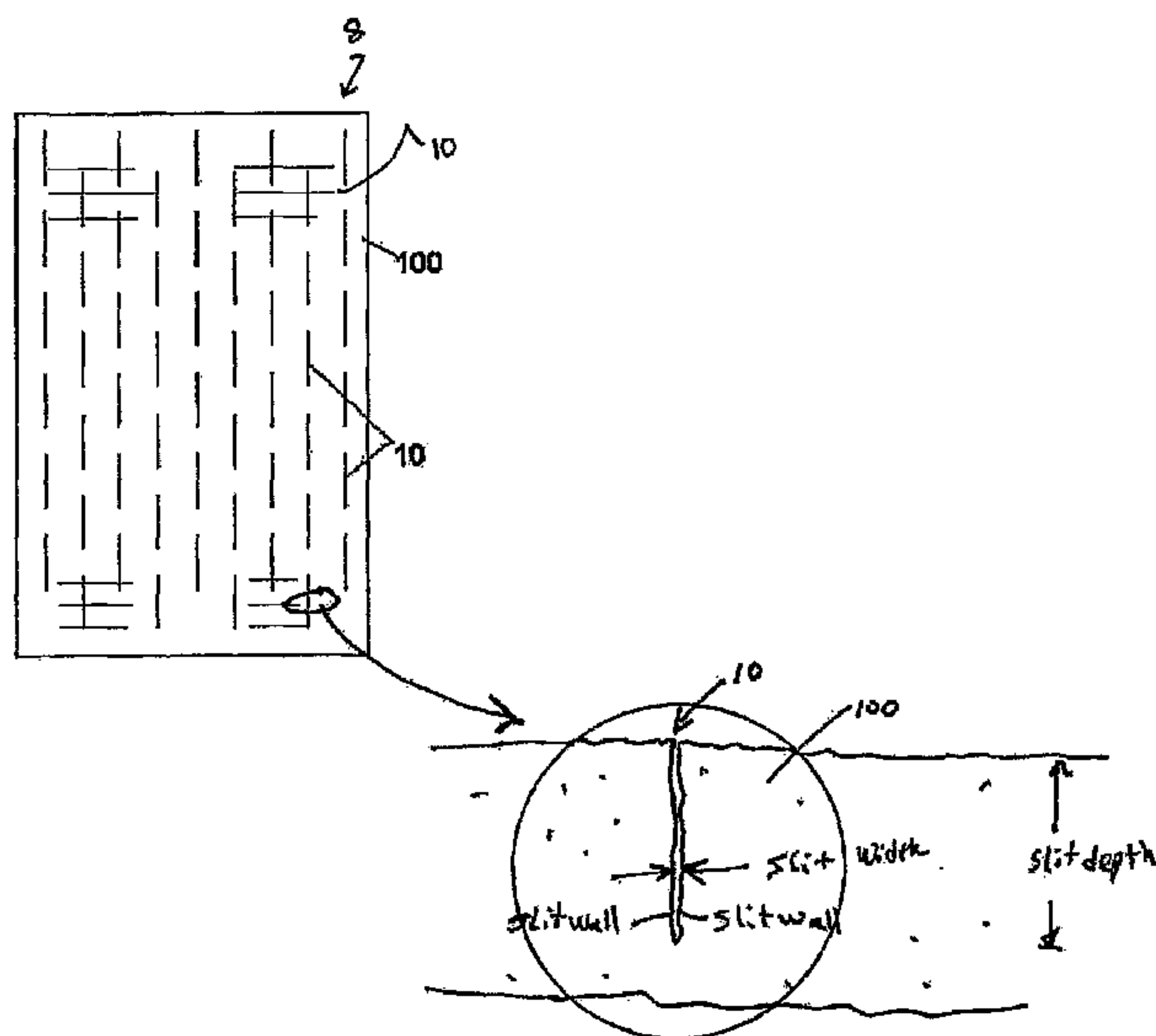

FIG. 2a

(57) Abstract: The invention relates to slit absorbent articles and the use of slits in absorbent materials to provide improved liquid intake rate, flexibility and softness compared to the unmodified material. The absorbent material, including superabsorbent materials, are particularly useful as absorbent cores in disposable absorbent articles such as diapers, incontinent products, sanitary napkins and the like.

  
**WO 2009/047596 A1**

## ABSORBENT ARTICLE WITH A SLIT ABSORBENT CORE

### CROSS-REFERENCE TO RELATED APPLICATIONS

**[0001]** This application claims priority under 35 U.S.C. 119(e) from provisional U.S. Patent Application No. 60/094,321 filed June 12, 2007 the contents of which are incorporated herein by reference.

### TECHNICAL FIELD

**[0002]** The present invention relates to liquid absorbing articles incorporating superabsorbents and, more particularly, to the use of slits in the absorbent core to provide the requisite properties of fast fluid intake, thinness, flexibility and softness.

### BACKGROUND OF THE INVENTION

**[0003]** Absorbent articles such as disposable diapers, adult incontinent pads, sanitary napkins and the like are generally provided with an absorbent core material to receive and retain body liquids. Typical compositions of absorbent core materials are particulate, absorbent, polymeric compositions, often referred to as "hydrogels" or "superabsorbents", which are capable of absorbing large quantities of liquids such as water and body exudates. Fibrous components such as pulp or other synthetic fibers are incorporated into the composite together with the superabsorbent to provide acceptable fluid handling characteristics of fast liquid intake, liquid capture and reduced "gel blocking". Gel blocking is a phenomenon that occurs when the swelling of the absorbent particles as a result of liquid absorption increases the resistance to liquid flow within the material. It is generally believed that the fibrous component provides stable interparticle liquid channels that minimize the gel blocking effect.

**[0004]** For fit, comfort and aesthetic reasons, it is highly desired to make disposable absorbent articles as thin as possible. Disposable absorbent articles can be reduced in thickness by reducing the absorbent core thickness. Thinner diapers are less bulky to wear, fit better and provide

**CONFIRMATION COPY**

more comfort to the wearer. To achieve the lowest absorbent core thickness for a given level of absorbent capacity, the superabsorbent content is preferably increased toward 100%, that is, the fiber component of the absorbent core is reduced to near zero percent. The composite of superabsorbent content and fiber component oftentimes is also subjected to densification to achieve and maintain reduced thickness. However, such absorbent composites generally display much slower liquid intake characteristics due to their high composite density, high gel blocking characteristics, low permeability to liquid passage that that cause liquid leakage. In addition, higher stiffness and rigidity of such structures lead to absorbent products with poor fit and comfort.

[0005] As disclosed in prior art, the slower liquid intake of superabsorbent-containing absorbent cores can be compensated for by adding liquid-holding layers of materials on top of the absorbent core. These are usually fibrous or film structures capable of accepting the liquid insult at its rate of delivery and temporarily holding the liquid until the absorbent core can fully absorb and retain the insult. These elements are termed surge or acquisition layers, as shown in US Pat. No. 5,364,382. However, increasing the number of surge layers to compensate for a much slower absorbing core adds to the thickness and cost of the absorbent article.

[0006] Other approaches such as discontinuous and patterned placement of the superabsorbent material or composite have been disclosed in the art, such as US Pat. Nos. 4,560,372 and 5,868,724. Voids are created in the absorbent composite, hence the surface coverage of the absorbent composite is less than 100%. Implementation of approaches is relatively complex. Furthermore the full area available for absorbency is not utilized, and consequently the article is thicker than one with a relatively uniform distribution of superabsorbent material.

[0007] Hence, there remains a need for an absorbent core that is thin, having high absorbent capacity with good fluid intake rate characteristics, soft, and flexible that can be used in absorbent articles such as disposable diapers, adult incontinent pads or briefs, sanitary napkins and the like.

## BRIEF SUMMARY OF THE INVENTION

[0008] The present invention is directed to the use of one or more slits within an absorbent composite of a disposable absorbent article. The one or more slits provide for high performance disposable absorbent articles which are thin, soft and flexible. Such an absorbent composite may be employed as the primary component of the absorbent core, together with a topsheet, a backsheet, containment walls or cuffs, and other elements (e.g., an acquisition layer) of the disposable absorbent article. Among the characteristics which may be exhibited by embodiments of the inventive absorbent article are improved fit and appearance, improved absorption and liquid containment properties, simpler, more efficient manufacturing process, and a thinner, more compact construction.

[0009] It is therefore an object of the invention to provide a disposable absorbent article having improved overall thinness, improved rate of liquid acquisition, and with an absorbent core which is soft and flexible.

[0010] The foregoing has outlined rather broadly the features and technical advantages of the present invention in order that the detailed description of the invention that follows may be better understood. Additional features and advantages of the invention will be described hereinafter which form the subject of the claims of the invention. It should be appreciated by those skilled in the art that the conception and specific embodiment disclosed may be readily utilized as a basis for modifying or designing other structures for carrying out the same purposes of the present invention. It should also be realized by those skilled in the art that such equivalent constructions do not depart from the spirit and scope of the invention as set forth in the appended claims. The novel features which are believed to be characteristic of the invention, both as to its organization and method of operation, together with further objects and advantages will be better understood from the following description when considered in connection with the accompanying figures. It is to be expressly understood, however, that each of the figures is provided for the purpose of illustration and description only and is not intended as a definition of the limits of the present invention.

## BRIEF DESCRIPTION OF THE DRAWINGS

[0011] For a more complete understanding of the present invention, reference is now made to the following descriptions taken in conjunction with the accompanying drawing, in which:

[0012] Figure 1 is a vertical cross-section illustration of the absorbent composite used as absorbent core;

[0013] Figure 2A is a top plan view of an absorbent core with a multiplicity of slits arranged in various patterns along the machine direction (MD) and cross direction (CD) wherein the slit is a partial slit traversing a portion of the full absorbent core thickness;

[0014] Figure 2B is a top plan view of an absorbent core with a multiplicity of slits arranged in various patterns along the machine direction (MD) and cross direction (CD) wherein the slit is a through slit traversing the full absorbent core thickness;

[0015] Figure 3 is a top plan view of an arrangement of an embodiment of the present invention having an absorbent core with long side slits to achieve side bending;

[0016] Figure 4 is a top plan view of an absorbent core with center and side slits and a multiplicity of smaller slits placed between the long slits;

[0017] Figure 5 is a top plan view of an absorbent core with patterned slits at ends and sides in addition to long side slits;

[0018] Figure 6 is a cross sectional view along the transverse direction of a layered absorbent composite showing a slit absorbent core as a top layer over an unslit absorbent core as a lower layer;

[0019] Figure 7 is a cross sectional view along the longitudinal direction of a layered absorbent composite showing a slit absorbent core as an upper layer positioned around the liquid target region and an unslit absorbent core as lower layer absorbent composite; and

[0020] Figure 8 depicts a top plan view and a perspective view of appropriately placed slits in the absorbent composite that provide bend areas and enable the absorbent article to follow the body curvature; and

[0021] Figure 9 and 10 are top plan views of shaped absorbents derived from a rectangular absorbent core through slitting and folding.

#### DETAILED DESCRIPTION OF THE INVENTION

[0022] It has been discovered that the addition of an adequate level of slitting to a absorbent composite causes a significant improvement in its liquid intake and a corresponding increase in softness and flexibility without an increase in composite thickness and without a reduction of machine direction (MD) strength. Machine direction strength is particularly advantageous to the manufacturing and processing of the absorbent articles.

[0023] For purposes of increasing liquid intake, the appropriate level of slitting should be greater than 0.1. By definition, a material that does not contain any slits has a "slit level" of zero. The level of slitting can be determined by summing the total slit perimeter formed from the multiplicity of slits used and normalizing the total slit perimeter to the planar area of the composite encompassing the slit region. For example, 5 slits that are 1 cm in length distributed in a 5 cm x 10 cm area of the absorbent would yield a slit level of  $0.2 \text{ cm}^{-1}$ . In this example, the total slit perimeter is  $1 \text{ cm} \times 2 \times 5 = 10 \text{ cm}$ ; planar area is  $5 \text{ cm} \times 10 \text{ cm} = 50 \text{ cm}^2$ ; and slit level is  $10 \text{ cm}/50 \text{ cm}^2 = 0.2 \text{ cm}^{-1}$ . For purposes of increasing softness and flexibility, the slit size and placement can be distributed according to a pattern that yields the appropriate improvement. In general, a higher slit level leads to both faster intake and higher softness and flexibility.

[0024] As used herein, the term "slit" is defined as a narrow cut, opening or aperture. The slit may be straight or curved and may be disposed in any planar orientation within the absorbent composite, including vertical or angled relative to the top surface. The slit depth may vary between slits and may also vary along a slit length. The slit depth can be equal to the thickness

of the absorbent core. Such slits can be referred to as "partial slits", such as shown in Figure 2A or as "through slits", such as shown in Figure 2B. During manufacturing of the absorbent article, the slitting of the absorbent core may take place before or after the absorbent core is connected to a back sheet.

[0025] Without being bound by theory, it is believed that the slit regions have higher liquid intake rate compared to the non-slit areas due to an increase in liquid permeability and an increase in surface area around the slit. Similarly, slits provide a material discontinuity and a region of zero or very low modulus that facilitates the bending or folding of the absorbent core along the slit region also resulting in a macroscopically flexible material. It is also possible that the slits facilitate capillary flow of liquid toward an interior of the absorbent core. Slit widths, defined as the distance between walls of a slit, may range from about 1 micron to about 1000 microns.

[0026] Appropriately placed slits in the absorbent core provide bend and fold lines that can be utilized in creating shaped absorbent cores from rectangular absorbent composites resulting in simpler and more efficient manufacturing processes. For example, in a diaper, long slits placed along the crotch area and towards the side edges of the absorbent core enables the folding inward of these outboard edges creating an "hourglass" shaped absorbent core that can provide enhanced fit. Moreover, because of such folding, more absorbent composite is added to the target area, and a bumper-like absorbent structure is created that can reduce leakage in the crotch area.

[0027] Other areas in the absorbent core can be selectively slit to provide the desired bending characteristics that enable the absorbent article to follow the body curvature for improved fit and appearance.

[0028] Slitting may be accomplished through shear, score or burst slitting such as provided by rotating or stationary knives, cutting dies, laser or water jet cutting. The absorbent material may also be subjected to mechanical softening prior to the addition of slits. Examples of such softening processes are creping, groove or ring-rolling, and embossing.



[0029] Figure 1 depicts a magnified illustration of an absorbent composite or core 100 used in an embodiment of the present invention. Core 100 may define one or more layers within an absorbent core of a disposable absorbent article 8, as shown in Figure 2A. Core 100 includes superabsorbent particles 102 which are covered or intermixed with extremely fine microfibrillated cellulose (MFC)104, embedded into the pores of a low-density nonwoven substrate 106 and a high density layer 108 of the nonwoven substrate 106. The superabsorbent content is preferably from 70-95%. A process of manufacturing the absorbent core 100 has been developed by the Japan Absorbent Technology Institute (JATI) and available under the trade name MEGATHIN. The details of the manufacturing process and other characteristics of the MEGATHIN sheet are described in US Pat. No. 6,790,798, hereby incorporated by reference.

[0030] The absorbent core 100 may include one or more layers or strata of natural or synthetic fibers. Superabsorbent polymers (SAP) may be incorporated into the absorbent layer as particles, granules, flakes, etc., and may be included as a discrete stratum or mixed with the aforementioned fibers. SAP particles of various type, size or shape suitable for use in an absorbent core may be employed in embodiments of the invention. Materials such as fillers, perfumes, surfactants, and additives may be included in the absorbent composite. In a preferred embodiment, the absorbent composite contains 50-97% by weight of SAP and 3-50% by weight of fibers. More preferred embodiments of the present invention include polyacrylate-based SAPs and resilient fibers such as polyester (PET), polyolefin (PP or PE), or nylon fibers (Hydrofil™).

[0031] Basis weights of the absorbent composite can be adjusted and optimized for particular purposes over a wide range. Furthermore, multiple layers of the absorbent composite can be assembled to achieve the desired total basis weight. Generally, the basis weight of a single absorbent composite layer can range, for example, from about 50 grams per square meter (gsm) to about 1000 gsm, and more specifically from about 100 to 500 gsm.

[0032] In preferred embodiments of the present invention, the absorbent core 100 (or layer portions thereof) is slit according to a predetermined pattern to increase fluid intake rate and

flexibility. The absorbent core 100 may include multiple layers, with slit patterns being different between layers. In one embodiment, core 100 includes two or more layers, with at least one layer having a slit pattern and another layer having substantially no slits.

[0033] Figure 2A and Figure 2B are top plan views of an absorbent core 100 with a multiplicity of short slits 10 arranged in various patterns along the machine direction (MD) and cross direction (CD). As noted previously, the number and length of the slits can be varied to deliver the intake performance and flexibility required. In this embodiment, a slit level of at least  $0.1 \text{ cm}^{-1}$  and a slit length of at least 0.2 cm is required.

[0034] Another exemplary embodiment is shown in Figure 3. The particular arrangement of the three slits, two long side slits 20 and center slit 30 encourages the folding of the absorbent core to form of an absorbent bucket that effectively reduces early leakage.

[0035] Figure 4 is another embodiment of the present invention with long center slit 30 and side slits 20, together with a multiplicity of smaller slits 10 placed between the long slits 20 and 30, to achieve higher liquid intake rates in addition to preferentially bucket formation.

[0036] Figure 5 is a top plan view of absorbent core 100 with patterned slits 40 at ends and sides in addition to long side slits 20. Slits patterned towards the ends of the product provide faster intake rates in those regions and hence reduce waist leakage. Absorbent core 100 construction may also include more than one absorbent composite layer. For example, a two-layer absorbent core structure can be assembled wherein the top layer 100 is slit 20 for enhanced intake and the bottom absorbent 200 remains unslit. Figure 6 is a cross sectional view taken along the transverse direction view of such a layered absorbent core structure. An example of the present invention may include a liquid pervious top sheet or an acquisition layer or both.

[0037] Figure 7 is a cross sectional view taken along the longitudinal direction of an absorbent article such as a diaper of a two-layer absorbent core structure described by Figure 6 and depicting the placement of the inventive slit structure centrally around the crotch area only.

[0038] Figure 8 illustrates the use of appropriately disposed slits 20 to provide bend areas that enable the absorbent article to follow the body curvature for improved fit and appearance.

[0039] In another embodiment illustrated by Figure 9, appropriately placed slits in the absorbent core 100 provide cut 40 and bend/fold lines 50 and yield a hourglass shaped absorbent composite from a rectangular absorbent composite. Similarly Figure 10 depicts an hourglass shaped absorbent composite created by slitting and folding along slit lines 20.

[0040] Exemplary embodiments of the present invention were subjected to experimentation. Descriptions of the test procedures follows.

[0041] **Intake Rate** - Intake rate is determined using the liquid strikethrough test. The test determines the time required for an absorbent composite to intake a preset amount of liquid. A reduction in liquid strikethrough time indicates an improvement in intake rate. The liquid strike through time is measured using the known Fluid Intake Flowback Evaluation (FIFE)-type test apparatus. In a typical experiment, three consecutive 40 ml quantities of test liquid (e.g., 0.9% saline solution) are applied to the absorbent core sample at 15 minute intervals and the respective strikethrough times are recorded.

[0042] **Flexibility** - Flexibility is determined using the drape stiffness test. This test determines the bending length of a material subject to cantilever bending without application of external forces. What is measured is the drape stiffness or resistance to bending of the material. Bending length is a measure of the interaction between material weight and material stiffness as shown by the way in which a fabric or a sheet bends under its own weight. This is a reflection of the stiffness of a planar material when bent in one plane under the force of gravity.

[0043] For example, a 10 cm x 5 cm specimen was slid, in a direction parallel to its long dimension, so that its leading edge projected from the edge of a horizontal surface. At predetermined lengths of specimen pushed past the leading edge of the horizontal surface, the vertical distance between the horizontal surface and the tip of the bent specimen was measured.

This vertical distance is commonly referred to as the material's bending length or flexibility. The greater the bending length, the easier the material is to bend. Thus higher bending lengths indicate a more flexible material. Materials can be tested for flexibility along the MD or cross direction (CD).

[0044] EXAMPLES: Column 1 of Table 1 provides the absorbent composites used in the accompanying examples in accordance with the present invention. These composites had a very high superabsorbent content, are thin and have a high composite density. The corresponding bulk density, calculated as the reciprocal of composite density is low, indicative of the thinness of the composite. The superabsorbent used was a polyacrylate-based SAP with a centrifuge retention capacity (CRC) of about 36 g/g, a free swell capacity of about 53 g/g, and an average particle diameter of 200-300 microns.

Table 1

	Super-absorbent (SAP)	SAP basis wt, gsm	Fiber components	Fiber components basis wt, gsm	%SAP in composite	Total absorbent basis wt, gsm	Thickness, cm	Density g/cc	Bulk Density, cc/g
1	Nippon Shokubai	125	92% PET, 8% MFC	30	80.65%	155	0.03	0.52	1.94
2	Nippon Shokubai	250	92% PET, 8% MFC	95	72.46%	345	0.075	0.46	2.17

Table 2

Absorbent	Top Layer	Slit Level cm <sup>-1</sup>	CD Flexibility, cm	Bottom Layer	Strikethrough time (s)		
					1	2	3
Top and bottom layers: 125 gsm MEGATHIN™, 80% SAP, 20% fiber, mechanically softened	slit	1.66	2.32	not slit	18.1	34.45	39.8
Top and bottom layers: 125 gsm MEGATHIN™, 80% SAP, 20% fiber, mechanically softened	not slit	0	1.66	not slit	33.55	38.75	40.25
		Effect of slitting top layer: % improvement in strikethrough time			46.05 %	11.10 %	1.12 %

[0045] The effect of slitting the absorbent core on intake rate and flexibility is shown in Table 2. Two layers of the absorbent composite were used. In this dual layer absorbent core

construction, only the top absorbent layer was slit. A slit length of 1.2 cm and a slit pattern similar to the pattern in Figure 2 was used. The slits were oriented in the machine direction (MD), staggered, spaced 0.6 cm apart in the MD and spaced 0.8 cm in the cross direction (CD). The slit level for this slit pattern was  $1.66 \text{ cm}^{-1}$ . The absorbent composites were also mechanically pre-softened by passing the composites through an embossing unit with intermeshed gears. The CD bending length at a 4 cm overhang (i.e., 4 cm of the inventive absorbent composite along its CD direction was projected past the edge of the horizontal surface) was measured and reported as the composite flexibility.

[0046] It is readily seen that the absorbent composite subjected to slitting according to the present invention had a significantly improved intake rate and flexibility.

[0047] Although the present invention and its advantages have been described in detail, it should be understood that various changes, substitutions and alterations can be made herein without departing from the spirit and scope of the invention as defined by the appended claims. Moreover, the scope of the present application is not intended to be limited to the particular embodiments of the process, machine, manufacture, composition of matter, means, methods and steps described in the specification. As one of ordinary skill in the art will readily appreciate from the disclosure of the present invention, processes, machines, manufacture, compositions of matter, means, methods, or steps, presently existing or later to be developed that perform substantially the same function or achieve substantially the same result as the corresponding embodiments described herein may be utilized according to the present invention. Accordingly, the appended claims are intended to include within their scope such processes, machines, manufacture, compositions of matter, means, methods, or steps.

## CLAIMS

What is claimed is:

1. A disposable absorbent article comprising:

an absorbent core including from about 50% to about 97% by weight of a superabsorbent material and from about 3% to about 50% by weight of fibers; and

a modified region of the absorbent core having a higher fluid intake rate as compared to an unmodified region, said modified region having a plurality of slits extending through at least a portion of said absorbent core, said slits promoting the higher fluid intake rate in at least the modified region.

2. The absorbent article in claim 1 wherein a slit level is greater than  $0.1 \text{ cm}^{-1}$ .

3. The absorbent article in claim 1 wherein said absorbent material includes a MEGATHIN composite.

4. The absorbent article of claim 1 wherein said absorbent core has a basis weight from about 50 grams per square meter (gsm) to about 1000 gsm.

5. The absorbent article of claim 4 wherein said absorbent core has a basis weight from about 100 gsm to about 500 gsm.

6. The absorbent article of claim 1 further comprising at least one region of material discontinuity, said at least one region facilitating folding of the absorbent core along said at least one region of material discontinuity.

7. The absorbent article of claim 6 wherein said at least one region of material discontinuity includes at least one slit extending through at least a portion of said absorbent core.

8. The absorbent article of claim 1 wherein the absorbent core is defined as a layer of absorbent material contained between two or more sheets.

9. The absorbent article in claim 8 wherein the absorbent core includes at least two layers of absorbent material disposed one on top of another.

10. The absorbent article of claim 9 wherein one of the at least two layers of absorbent material is not modified with slits.

11. An absorbent article comprising:

a liquid impervious back sheet; and

an absorbent core containing at least one layer of superabsorbent material (SAP) and including a plurality of slits extending through at least a portion therethrough, said plurality of slits facilitating greater liquid intake of said absorbent core as compared to an identical, but non-slitted, core, and further facilitating improved flexibility of the absorbent core in a predetermined direction..

12. The absorbent article of claim 11 wherein at least some of the plurality of slits extend from a top surface of the absorbent core towards the back sheet.

13. The absorbent article of claim 12 further comprising a top sheet or an acquisition layer or both.

14. The absorbent article of claim 11 wherein the absorbent core includes from about 50% to about 97% by weight of superabsorbent material and from about 3% to about 50% by weight of fibers.

15. The absorbent article in claim 11 wherein a slit level is greater than  $0.1 \text{ cm}^{-1}$ .

16. The absorbent article of claim 11 wherein said absorbent layer has a basis weight from about 50 grams per square meter (gsm) to about 1000 gsm.

17. The absorbent article of claim 16 wherein said absorbent material layer has a basis weight from about 100 gsm to about 500 gsm.
18. The absorbent article of claim 11 wherein the absorbent core is folded along at least one region of material discontinuity.
19. The absorbent article in claim 11 wherein said absorbent core is subjected to a mechanical softening process.
20. The absorbent article in claim 11 wherein the absorbent core is folded along two or more lines of material discontinuity, wherein said two or more lines are oriented in a product longitudinal direction and located about a central region of the absorbent article, thereby defining an hourglass shape.
21. The absorbent article in claim 11 with the absorbent core further comprising:  
a second layer of SAP material having substantially fewer slits as compared to the other layer.
22. A method of manufacturing a disposable absorbent core comprising:  
providing a generally liquid impervious back sheet;  
connecting an absorbent core to said back sheet, said core including at least one layer containing superabsorbent material; and  
slitting said at least one layer of said absorbent core, said slitting improving the liquid intake or flexibility of the absorbent core as compared to a similar, but non-slitted, core.
23. The method of claim 22 wherein said providing includes unrolling the back sheet from a roll.



24. The method of claim 22 wherein said connecting includes an adhesive bonding between said absorbent core and back sheet.

25. The method of claim 22 wherein said slitting occurs after said absorbent core is connected to said back sheet.

26. The method of claim 22 wherein said slitting occurs before said absorbent core is connected to said back sheet.

27. The method of claim 22 wherein said absorbent core includes a second layer containing a superabsorbent material and having substantially fewer slits as compared to the slit layer.

28. The method of claim 27 wherein said second layer has no slits.

29. The method of claim 22 wherein the at least one absorbent layer includes from about 50% to about 97% by weight of superabsorbent material and from about 3% to about 50% by weight of fibers.

30. The method of claim 22 wherein said slitting defines an absorbent core having a slit level of greater than  $0.1 \text{ cm}^{-1}$ .

31. The method of claim 22 wherein said absorbent core includes a MEGATHIN composite.

32. The method of claim 22 further comprising:

folding the absorbent core along at least one region of material discontinuity.

33. The method of claim 32 wherein said at least one material discontinuity is defined by one or more slits.

34. The method of claim 32 further comprising:

mechanically softening the absorbent core.

35. The method of claim 22 wherein said absorbent core is modified by folding along two or more parallel lines of material discontinuity, wherein said lines are oriented in a product longitudinal direction and located about a central region, said folding producing an hourglass shaped absorbent article.

36. The method of claim 22 wherein said slitting provides a plurality of individual slits aligned in generally in a machine direction.

37. The method of claim 22 wherein said slitting provides a plurality of slits of different lengths.

38. The method of claim 22 wherein said slitting provides a plurality of slits of different depths.

39. The method of claim 22 wherein said slitting provides a plurality of slits of different depths, including slits extending through the absorbent core.

40. The method of claim 22 wherein said slitting provides a plurality of curved slits or linear slits or both.

41. The method of claim 22 wherein said slitting provides a plurality of slits having different angular orientations relative to a machine direction.

42. The method of claim 22 wherein at least some of the slits extending along a substantial portion of a length of the absorbent article.

43. The method of claim 42 wherein said absorbent article is folded about said at least some of the slits to improve user fit or comfort.

44. The method of claim 22 wherein said slitting is defined by a cutting process.

45. The method of claim 44 wherein the cutting process includes a die-cutting process, a shear process, a score process, burst slitting.

46. The method of claim 45 wherein the cutting process is provided by rotating or stationary knives, cutting dies, laser or water jet cutting.

47. The method of claim 34 wherein said mechanically softening occurs prior to said slitting.

48. The method of claim 47 wherein said mechanically softening includes one or more of creping, grooving, ring-rolling and embossing.

49. A method of processing a disposable absorbent article comprising:

providing a generally liquid impervious back sheet;

connecting an absorbent core to said back sheet, said core including at least one layer containing a superabsorbent material; and

imparting a plurality of slits upon said at least one layer of said absorbent core, with at least a substantial portion of said slits being aligned generally in a machine direction so that a machine direction strength is insubstantially decreased as compared to a similar, though non-slitted, absorbent core.

50. The method of claim 49 wherein said imparting provides a patterned array of slits, with at least some of the slits promoting easier folding of the absorbent article along said at least some of the slits.

51. A method of manufacturing a disposable absorbent article comprising:

providing a fluid impervious back sheet;

connecting an absorbent core to said back sheet, with said core including a layer of superabsorbent material; and

slitting at least a portion of said region of superabsorbent material so as to impart greater flexibility and greater liquid intake of said core as compared to a similar non-slit core.

52. The method of claim 51 wherein said slitting renders said absorbent core more flexible about an axis generally aligned in a predetermined direction as compared to a similar non-slit absorbent core.

53. The method of claim 52 wherein said predetermined direction is aligned in a machine direction.

54. The method of claim 52 wherein said predetermined direction is substantially offset from a machine direction.

55. A method of improving liquid intake of a disposable absorbent article comprising: imparting a plurality of slits upon a portion of an absorbent core of the absorbent article, said portion containing a superabsorbent material, and said imparting rendering said absorbent core with a greater liquid intake rate as compared to a similar, though non-slit, absorbent core.

56. A method of claim 55 with said plurality of slits providing quicker liquid access to an interior portion of the absorbent core to increase a liquid intake of the absorbent core as compared to the similar, though non-slit, core.

57. A method of manufacturing a disposable absorbent article comprising:

selectively defining one or more regions of greater liquid uptake upon an absorbent core having superabsorbent material; and

slitting the absorbent core to provide a plurality of slits, with a greater number of slits per unit area defining a region of greater liquid intake as compared to another region having a fewer number of slits per unit area.

58. The method of claim 57 wherein said one or more regions of greater liquid intake are defined in a manner dependent upon an end use of the absorbent article.

59. The method of claim 57 wherein said slitting defines a patterned region of increased flexibility as compared to another less-flexible region.

60. An absorbent article comprising:

an absorbent core containing at least one layer of superabsorbent material (SAP) and including a plurality of slits extending through at least a portion therethrough, said plurality of slits having a slit width of between 1 micron and 1000 microns to support a capillary flow of liquid into an interior of the absorbent core, said slits facilitating improved liquid intake of said absorbent core as compared to an identical, but non-slit, core.

61. The absorbent article of claim 60 further comprising a liquid pervious sheet positioned between a user and the absorbent core.

62. The absorbent article of claim 61 wherein the plurality of slits are selectively defined upon the absorbent core in pattern selected to control liquid flow into the absorbent core.

1 of 7

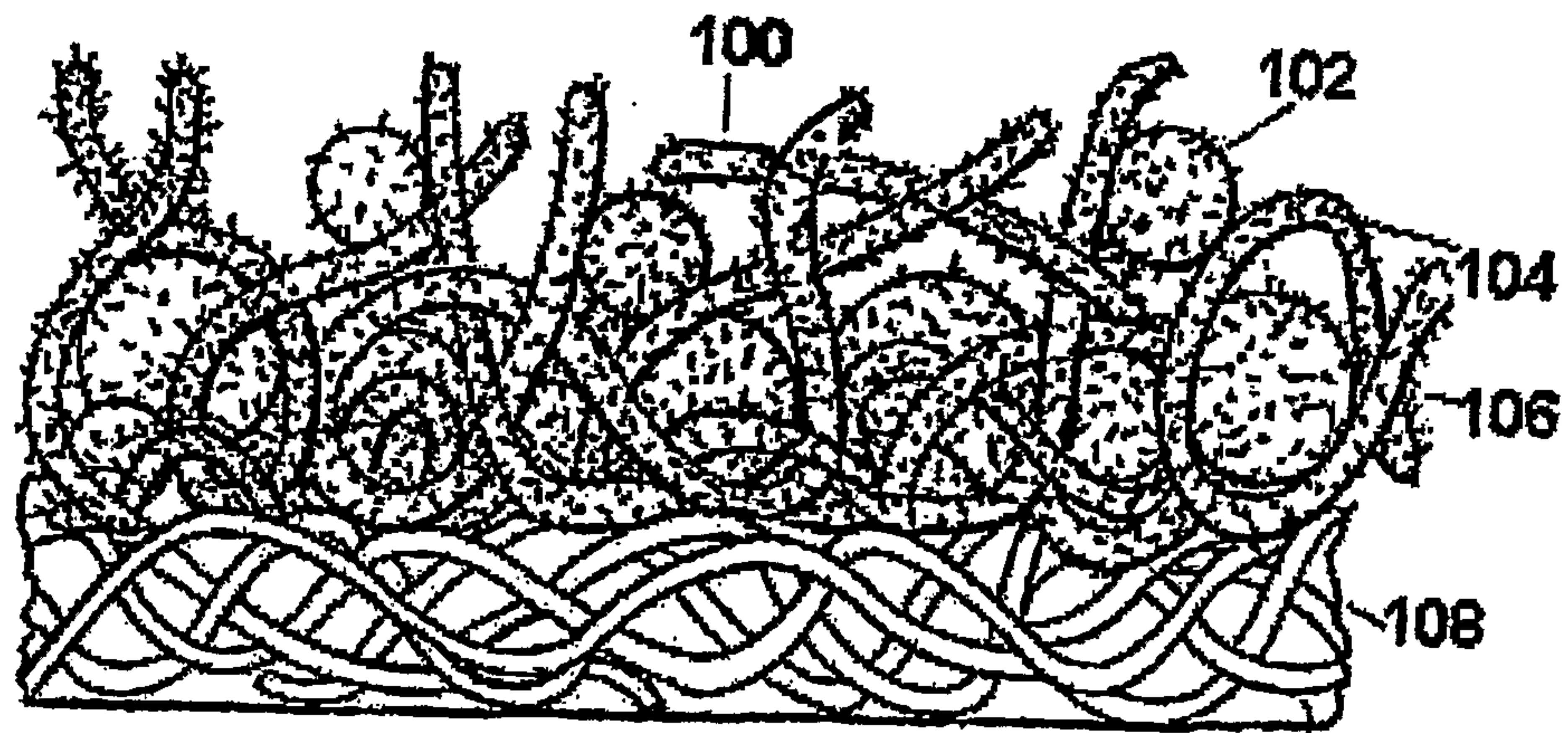

FIG. 1

2 of 7

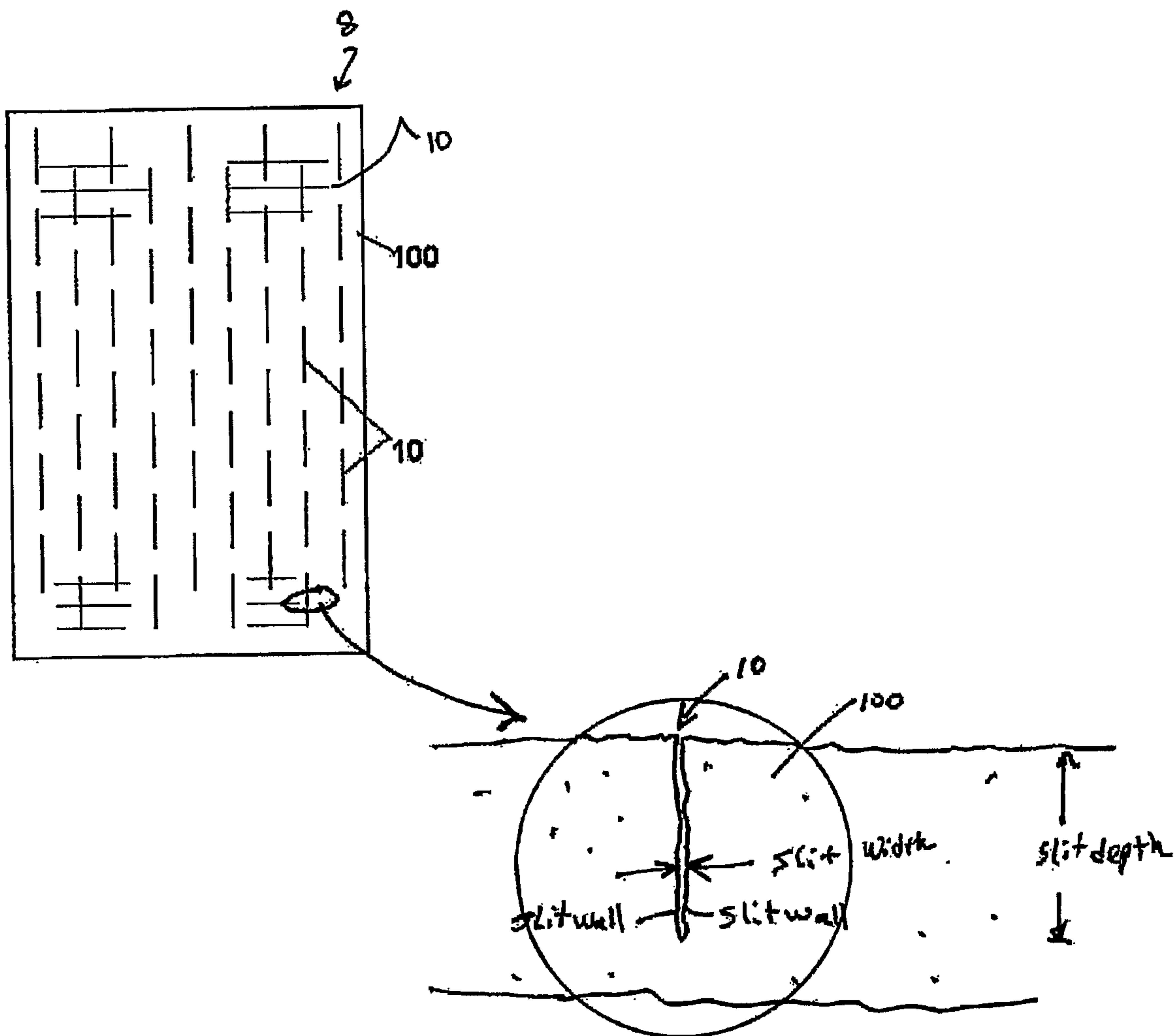

FIG. 2a

3 of 7

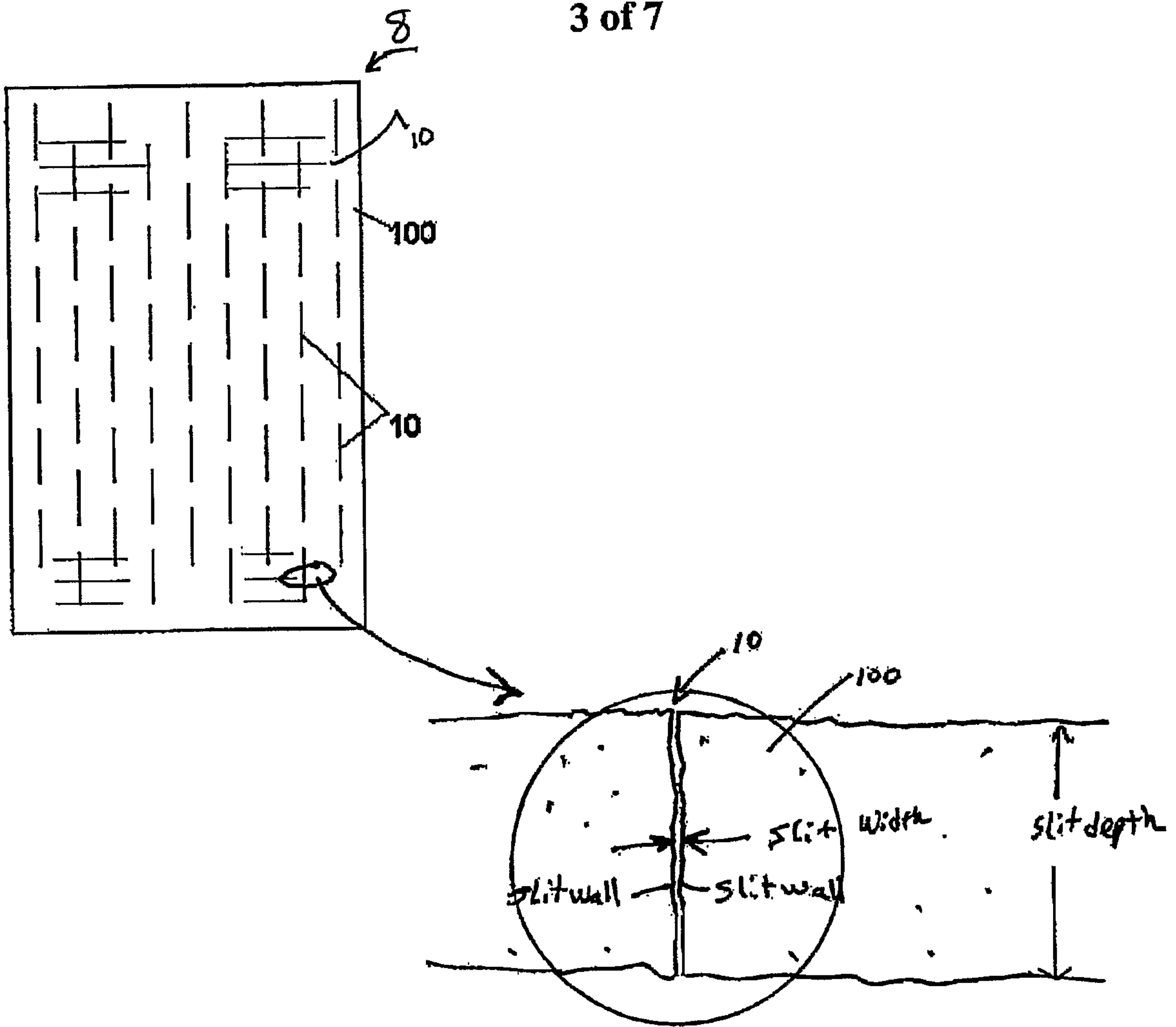

FIG. 2b



4 of 7

8

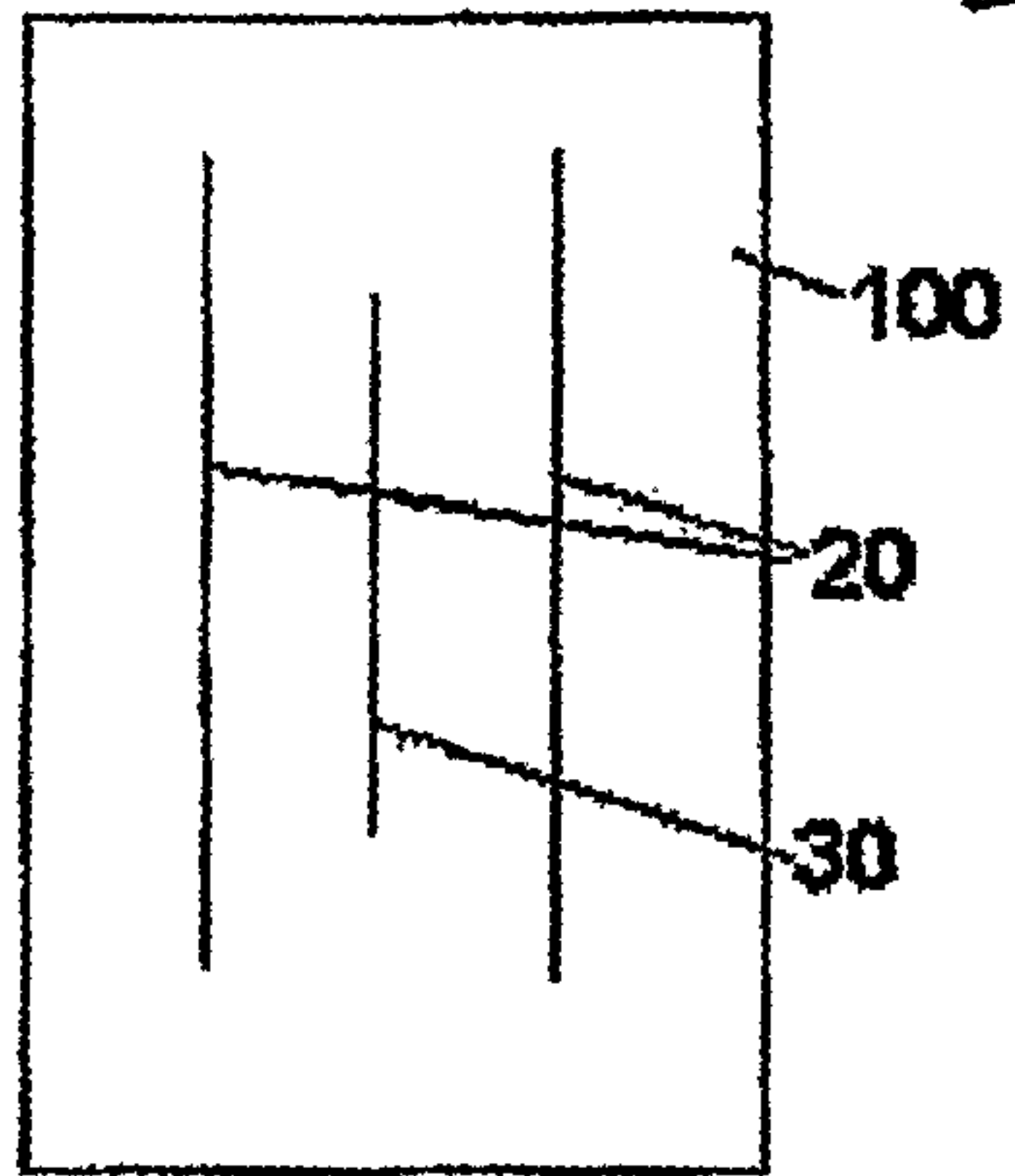

FIG. 3

8

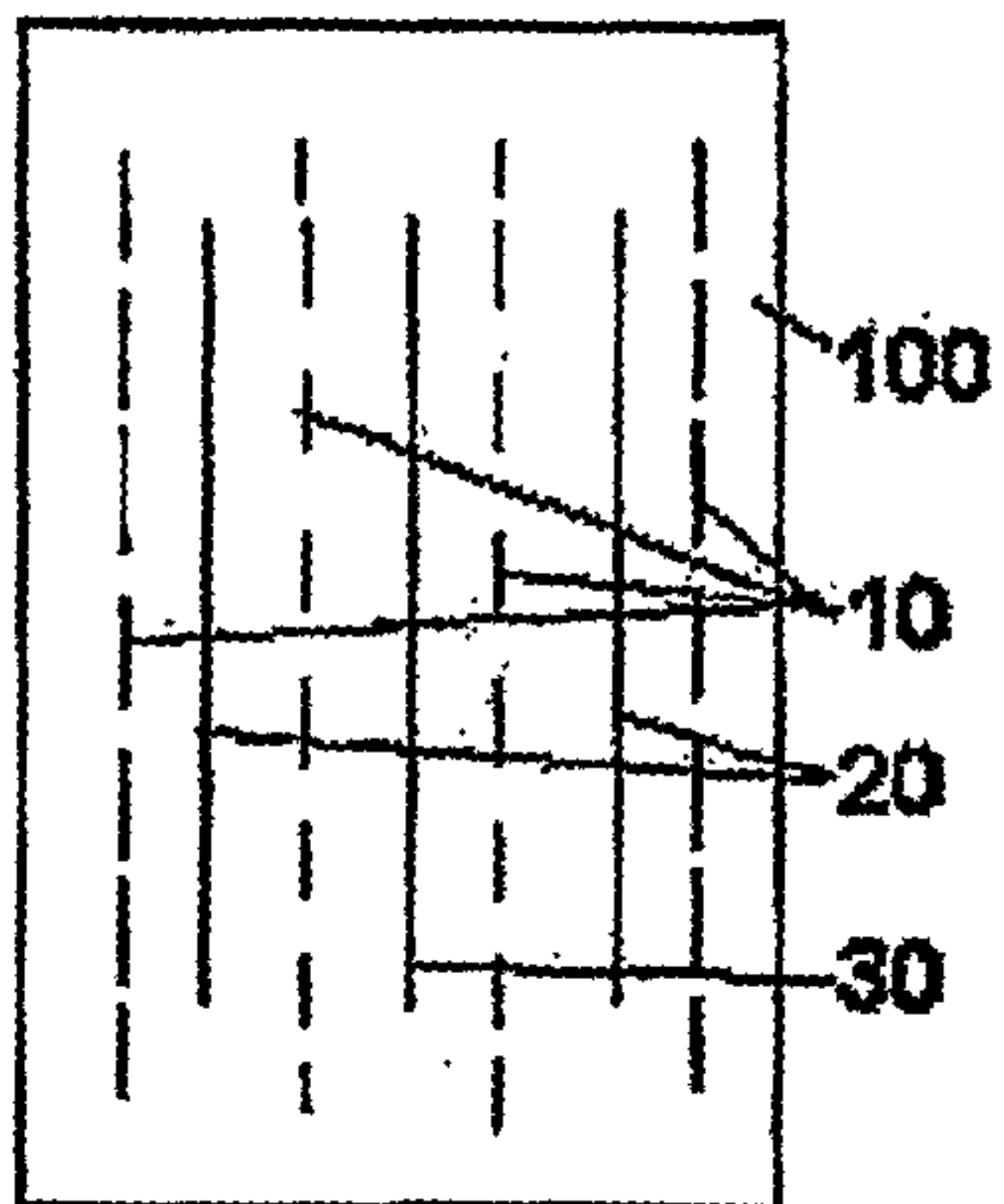

FIG. 4

8

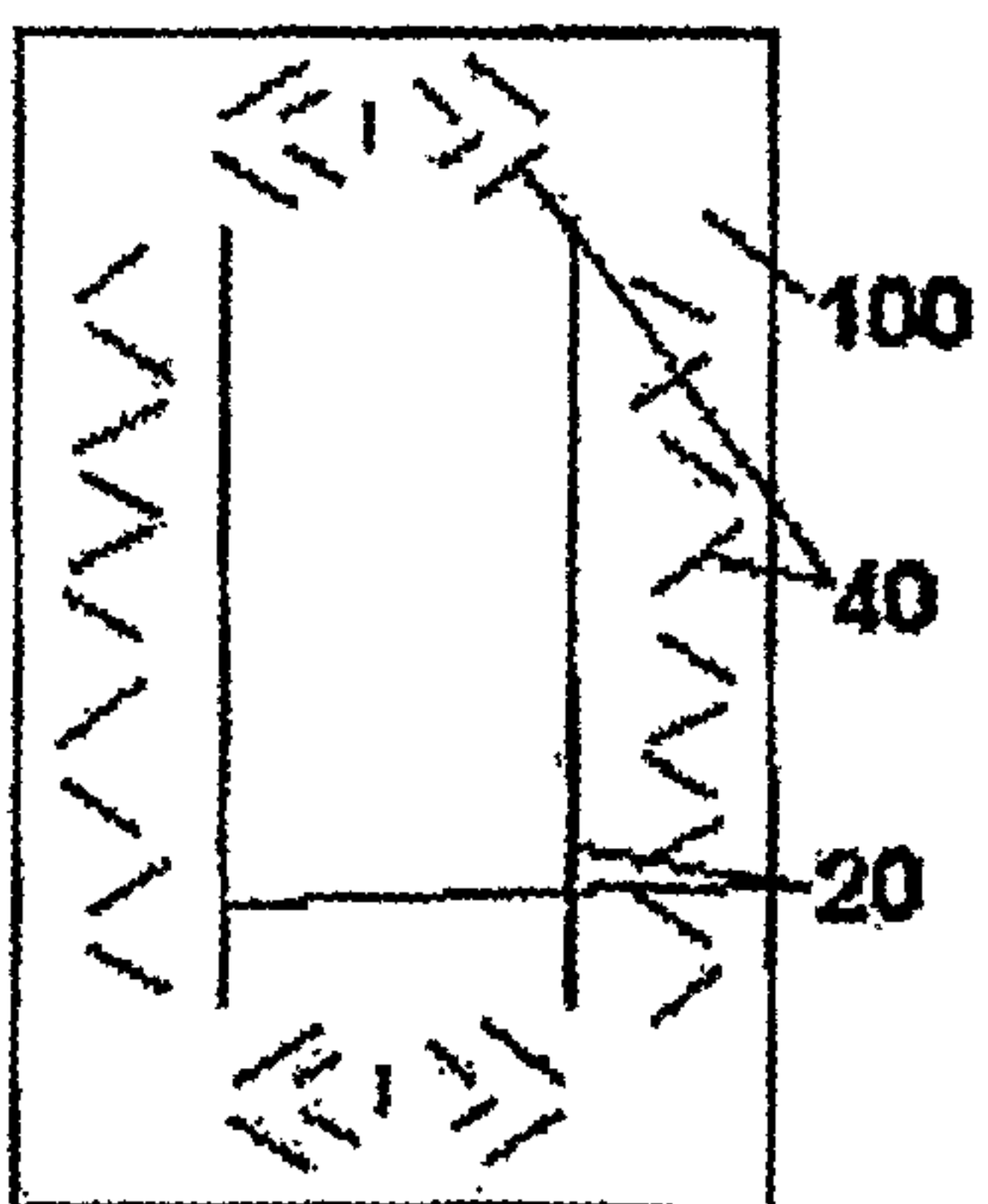

FIG. 5

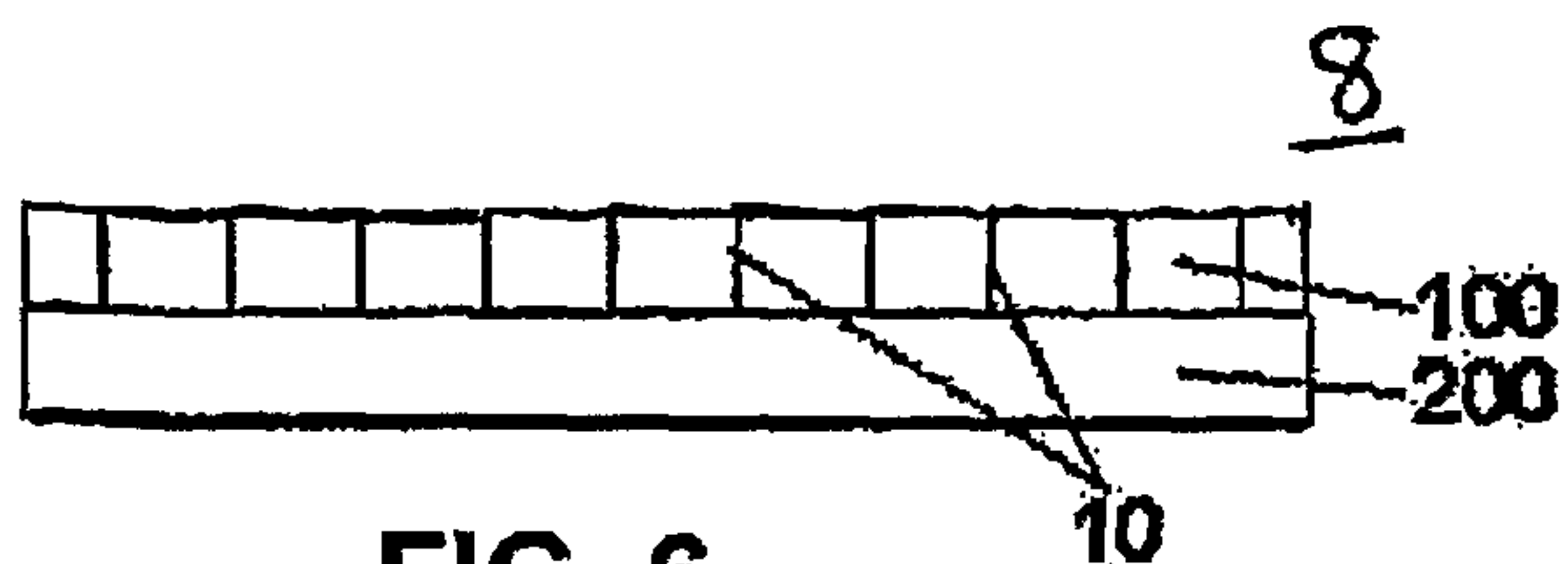

FIG. 6

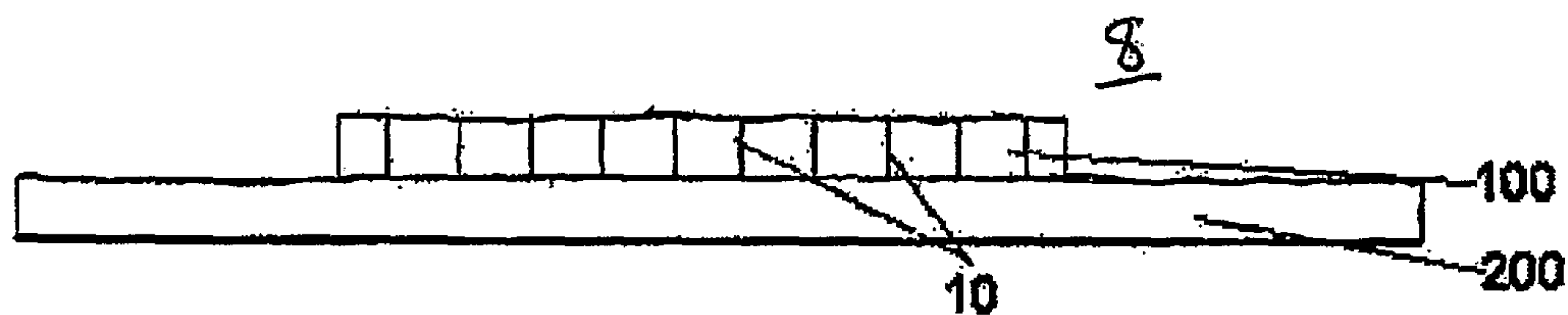

FIG. 7

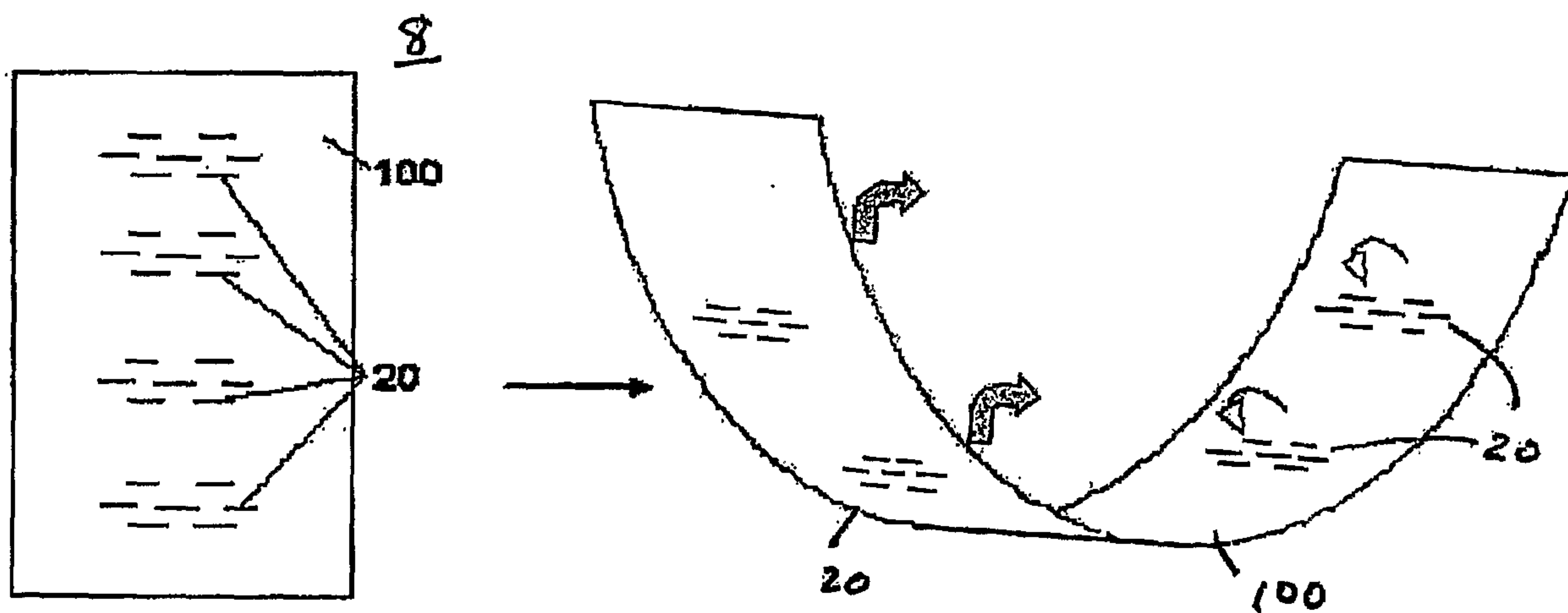

FIG. 8

6 of 7

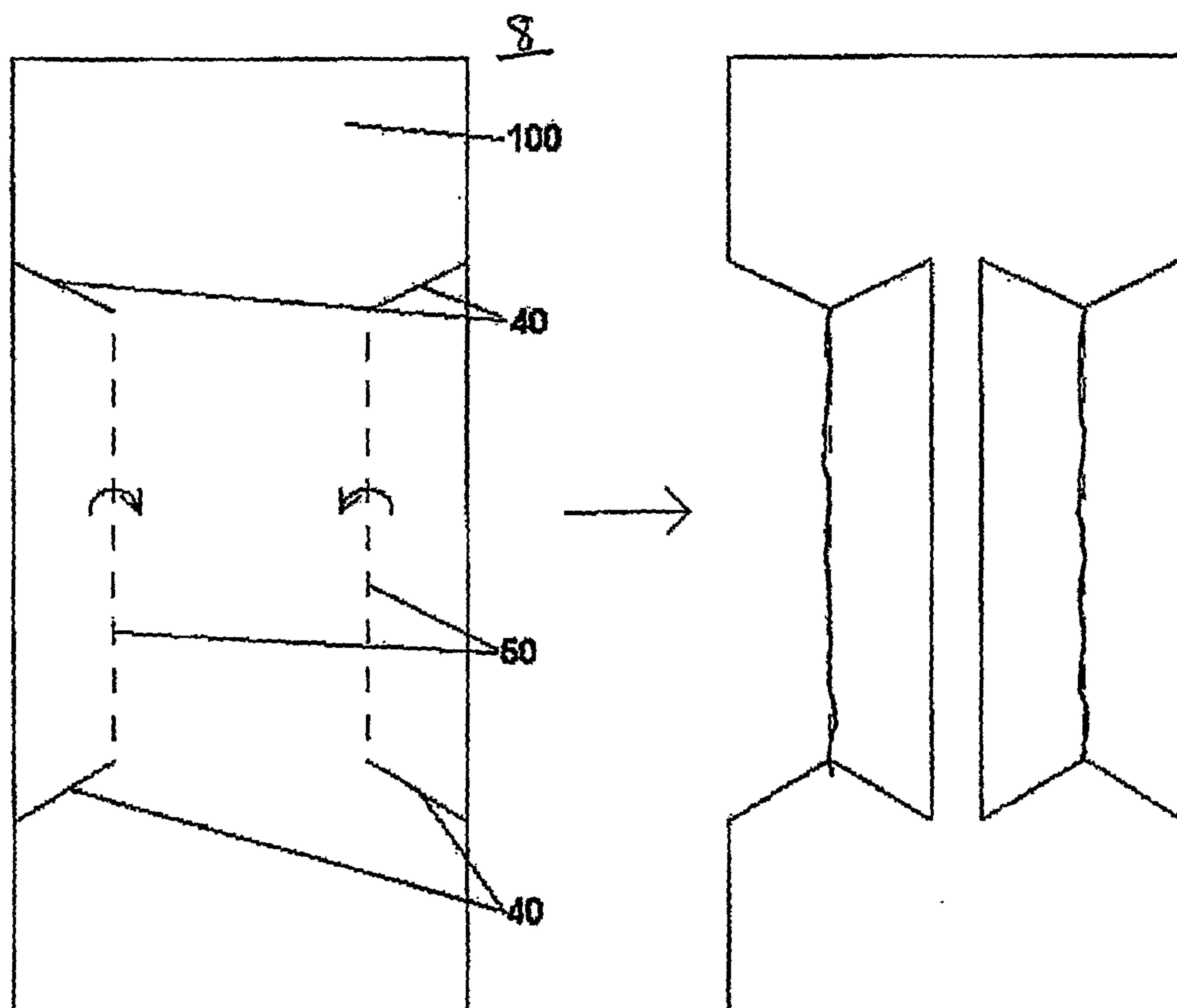

FIG. 9

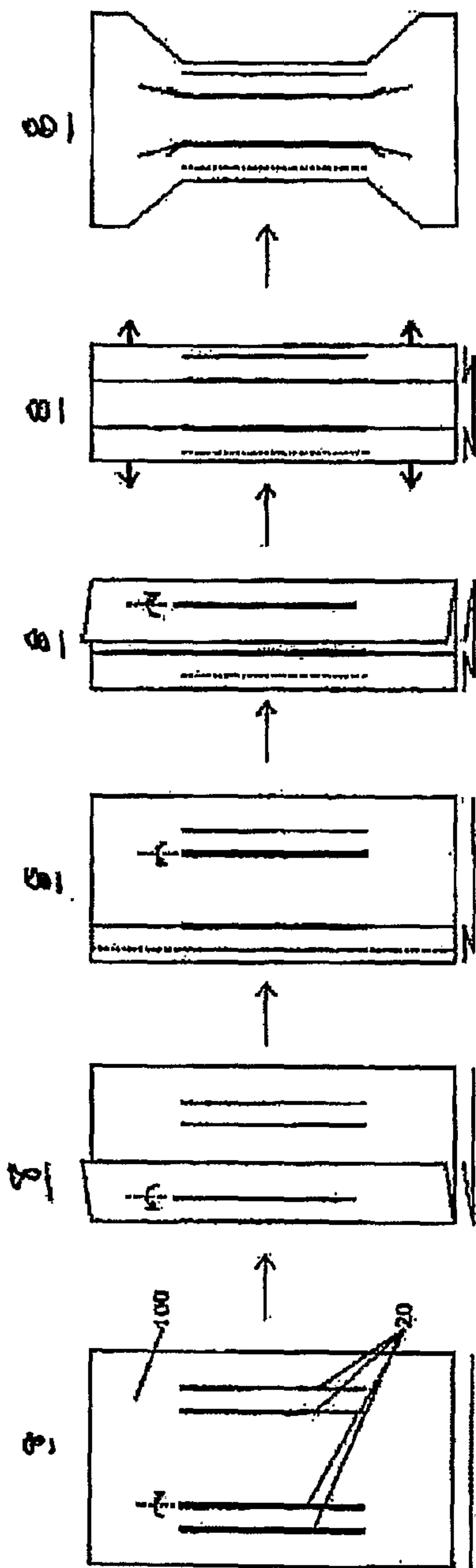

FIG. 10

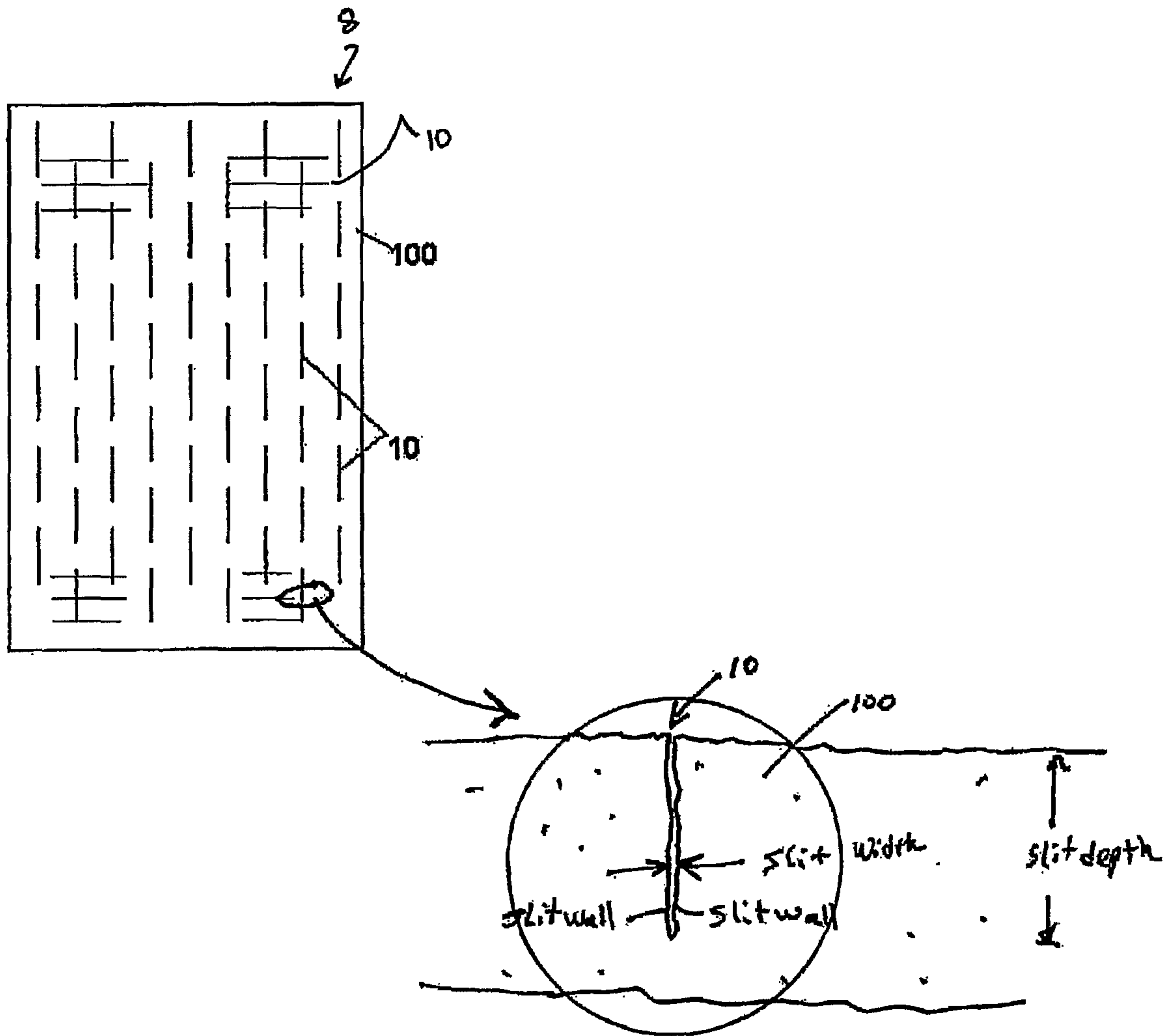

FIG. 2a