

D. TURNER.

Improvement in the Manufacture of Tin-Coated Lead-Pipe.

No. 131,072.

Patented Sep. 3, 1872.

Fig. 1.

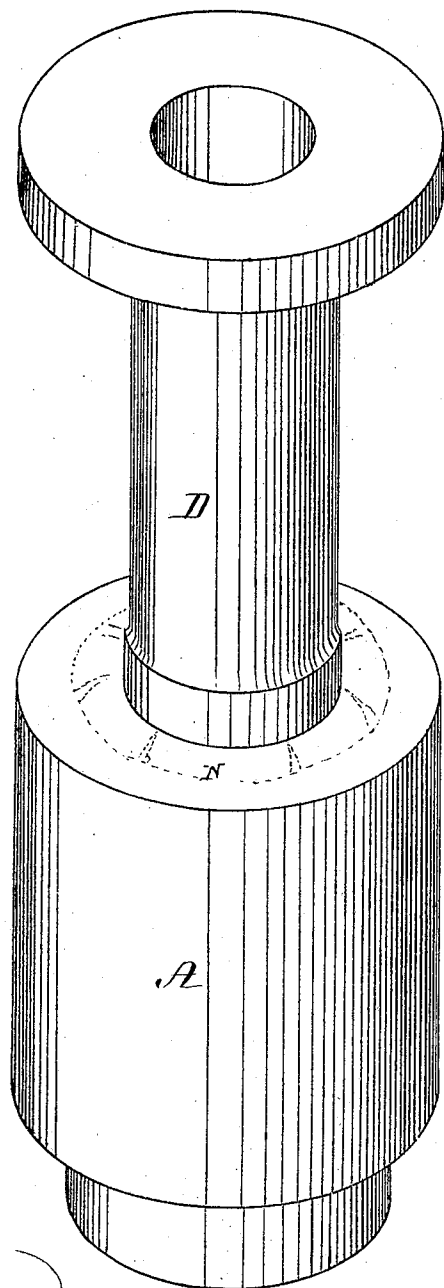

Witnesses,
N. W. Stearns
H. J. Cambridge

Inventor,
Daniel Turner

D. TURNER.

Improvement in the Manufacture of Tin-Coated Lead-Pipe.

No. 131,072.

Fig. 2.

Patented Sep. 3, 1872.

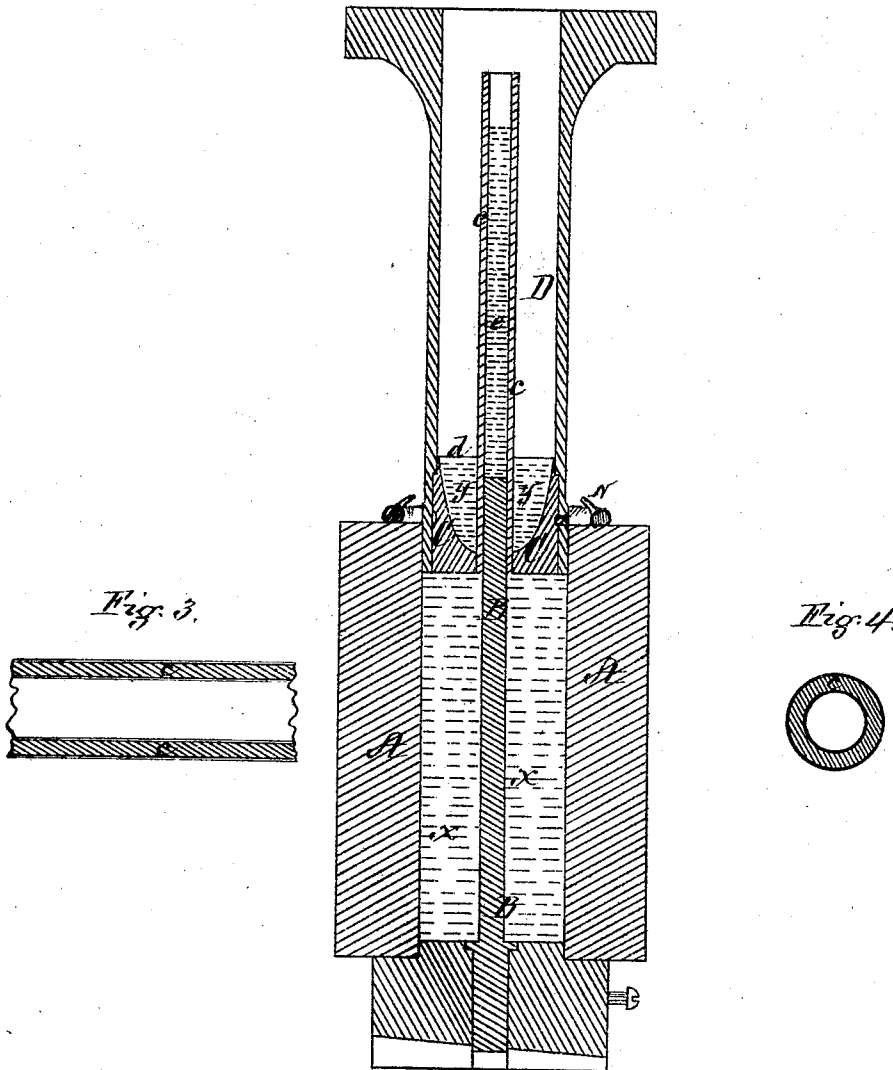

Witnesses,
N. W. Stearns
H. J. Cambridge

Inventor,
Daniel Turner

UNITED STATES PATENT OFFICE.

DANIEL TURNER, OF CAMBRIDGEPORT, ASSIGNOR TO ABRAHAM K. LISSBERGER, OF BOSTON, MASSACHUSETTS.

IMPROVEMENT IN THE MANUFACTURE OF TIN-COATED LEAD PIPE.

Specification forming part of Letters Patent No. 131,072, dated September 3, 1872.

To all whom it may concern:

Be it known that I, DANIEL TURNER, of Cambridgeport, in the county of Middlesex and State of Massachusetts, have invented a Process of Making Tin-Coated Lead Pipe, of which the following is a full, clear, and exact description, reference being had to the accompanying drawing making part of this specification, in which—

Figure 1 is a perspective view of the apparatus employed in my process of making tin-coated lead pipe. Fig. 2 is a longitudinal vertical section through the center of the same; Figs. 3 and 4, sections through my improved pipe.

In many localities lead pipe cannot be used with safety for conveying water used for drinking purposes on account of its acting upon or corroding the lead. To obviate this difficulty lead pipe has been provided with a lining of tin, the pipe being formed by drawing a lead pipe over one formed of tin. This pipe is, however, expensive, and in the process of manufacture the interior tin tube is liable to be drawn down quite thin in some places, and frequently leaves portions of the lead bare and exposed to the action of the water, thus defeating the object in view. Pipes composed of other metals, such as copper, brass, and iron, have also been employed, but they are expensive and liable to rust.

My invention has for its object to overcome these difficulties; and consists in a process of coating lead pipe with tin, both or either on the inside and outside, while the molten tin is kept in an even state of heat, a pipe so made being much superior to and cheaper than the tin-lined lead pipe heretofore used, while the coating of tin is of uniform thickness throughout, leaving no portion of the lead exposed to the action of the water.

To enable others skilled in the art to understand and use my invention, I will proceed to describe the manner in which I have carried it out.

In the drawing, A represents the cylinder or "lead-container" of an hydraulic apparatus for making lead pipe. From the bottom of this cylinder projects a removable and adjustable steel rod or core, B, which passes up through an opening of larger diameter in the bottom

of the die C, which is held by a set-screw, *a*, within the lower end of the hollow ram D, the lower portion of which is made to exactly fit the interior of the cylinder A, which is filled with lead, *x*, Fig. 2. The ram D is stationary, being bolted to a beam or frame above, not shown, while the cylinder A is forced up over the ram by hydraulic pressure applied from beneath, the lead being forced through the annular space between the core B and the sides of the opening through the bottom of the die C, thus forming the pipe which passes up through the hollow ram, and is afterward wound up on a reel, (not shown.) The apparatus above described has the die C provided with a cup-shaped recess, *d*, for containing molten tin, *y*, Fig. 2, and the cylinder A is constructed so as to carry a heater with it as moves upward.

I will now describe my process of making tin-coated lead pipe with this apparatus. The cylinder A having been filled with lead *x*, preferably molten, which is allowed to cool slightly, is elevated by hydraulic pressure until a length of pipe is formed extending up above the top of the die C. Molten tin is then introduced into the cup *d*, where it is kept at an even heat by a heater on the cylinder A, and, as the cylinder A continues to rise, the lead pipe as fast as it is formed passes up through the molten tin *y* in the cup *d*, causing the pipe to receive a thin coating of tin on its exterior surface. As soon as the top of the pipe *c* has risen about four feet above the die a suitable quantity of molten tin is poured into it, as seen at *e*, Fig. 2, the melted tin resting on the top of the steel core B, and thus, as the pipe *c* continues to rise from the die C, it will receive a coating of tin on the inside at the same time that it is coated on the outside by passing up through the molten tin in the cup *d*. The quantity of tin poured into the pipe *c* and into the cup *d* is sufficient to coat all of the pipe formed at a single operation of the apparatus—say, from one hundred and fifty to two hundred feet.

It is evident that the tin coating will not be regular and perfect on the lead pipe unless the melted tin be kept at an evenness of heat during the whole process, and to secure this result is the purpose of having my cylinder A

to move while the die and ram are stationary, as described. By this construction I am enabled to place my heater on the top of the cylinder A, and, as it moves up the ram, the heat is regularly imparted to the melted tin until the whole operation is completed.

Lead pipe coated both on the inside and outside in accordance with my invention is superior to any other pipe for conveying water used for drinking purposes, while its cost only slightly exceeds that of ordinary lead pipe; furthermore, the exterior coating of tin gives a beautiful finish to the pipe, which is a great advantage when used in dwellings or in other situations where it is exposed to view, or under ground, where lead is liable to decay.

Claim.

What I claim as my invention, and desire to secure by Letters Patent, is—

1. The within-described process of making tin-coated lead pipe.

2. I also claim a machine for making metal pipe wherein the cylinder containing the metal travels upward and over a stationary die or ram, for the purpose set forth, and as herein described.

3. I also claim the heater N or its equivalent, combined and arranged with the ram D and cylinder A so as to operate substantially as set forth.

Witness my hand this 7th day of August, A. D. 1872.

DANIEL TURNER.

In presence of—

N. W. STEARNS,
W. J. CAMBRIDGE.