

(12) INTERNATIONAL APPLICATION PUBLISHED UNDER THE PATENT COOPERATION TREATY (PCT)

(19) World Intellectual Property Organization
International Bureau



(43) International Publication Date
25 May 2001 (25.05.2001)

PCT

(10) International Publication Number
WO 01/35857 A1

- (51) International Patent Classification⁷: A61F 2/01
- (21) International Application Number: PCT/US00/31402
- (22) International Filing Date:
15 November 2000 (15.11.2000)
- (25) Filing Language: English
- (26) Publication Language: English
- (30) Priority Data:
09/440,204 15 November 1999 (15.11.1999) US
- (71) Applicant: SCIMED LIFE SYSTEMS, INC. [US/US];
One SciMed Place, Maple Grove, MN 55311 (US).
- (72) Inventors: TSUGITA, Ross; 1653 Gretel Lane, Mountain View, CA 94040 (US). CHANG, Jean; 645 Clyde Avenue, Mountain View, CA 94043 (US).
- (74) Agents: SEAGER, Glenn, M. et al.; Crompton, Seager & Tuft, LLC, Suite 895, 331 Second Avenue South, Minneapolis, MN 55401-2246 (US).
- (81) Designated States (*national*): CA, JP.
- (84) Designated States (*regional*): European patent (AT, BE, CH, CY, DE, DK, ES, FI, FR, GB, GR, IE, IT, LU, MC, NL, PT, SE, TR).
- Published:**
— With international search report.
— Before the expiration of the time limit for amending the claims and to be republished in the event of receipt of amendments.
- For two-letter codes and other abbreviations, refer to the "Guidance Notes on Codes and Abbreviations" appearing at the beginning of each regular issue of the PCT Gazette.*

(54) Title: GUIDEWIRE FILTER AND METHODS OF USE

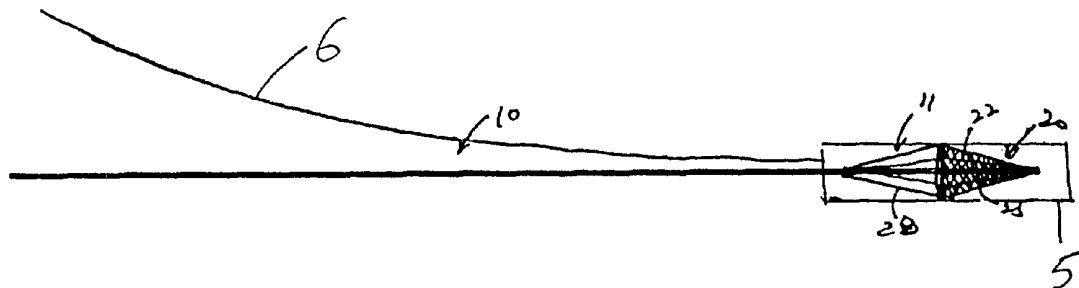

(57) Abstract: A filter system for temporary placement of a filter in an artery or vein is disclosed. The filter system includes a guidewire that is first positioned across a lesion within a vessel. The guidewire may include a distal stop. A slideable filter is then advanced along the guidewire using an advancing mechanism, typically an elongate member slideable over the guidewire and contacting the filter. A capture sheath may be disposed about the filter during advancement. Once the filter is positioned downstream of the lesion, the capture sheath is withdrawn, allowing the filter to expand. Further distal advancement of the filter is prohibited by the stop. After expansion of the filter, the capture sheath and the advancing mechanism are withdrawn from the region of interest, and removed from the patient's vessel. The filter may then be retrieved using a capture sheath or exchanged for a second filter after removing the first filter.



WO 01/35857 A1

S P E C I F I C A T I O N

GUIDEWIRE FILTER AND METHODS OF USE

Field of the Invention

5 The present invention relates generally to devices and methods for providing temporary placement of a filter in a blood vessel. More particularly, the invention provides a filter cartridge system for entrapment of embolic material in an artery or vein during an endovascular procedure. The system permits the replacement of the filter cartridge without requiring the removal of the guidewire during the endovascular
10 procedure.

Background of the Invention

Treatment of thrombotic or atherosclerotic lesions in blood vessels using an endovascular approach has recently proven to be an effective and reliable alternative to
15 surgical intervention in selected patients. For example, directional atherectomy and percutaneous transluminal coronary angioplasty (PTCA) with or without stent deployment are useful in treating patients with coronary occlusion. Atherectomy physically removes plaque by cutting, pulverizing, or shaving in atherosclerotic arteries using a catheter-deliverable endarterectomy device. Angioplasty enlarges the diameter
20 of a stenotic vessel by exerting mechanical force on the vascular walls. In addition to using angioplasty, stenting, and/or atherectomy on the coronary vasculature, these endovascular techniques have also proven useful in treating other vascular lesions in, for

example, carotid artery stenosis, peripheral arterial occlusive disease (especially the aorta, the iliac artery, and the femoral artery), renal artery stenosis caused by atherosclerosis or fibromuscular disease, superior vena cava syndrome, and occlusive iliac vein thrombosis resistant to thrombolysis.

5 It is well recognized that one of the complications associated with endovascular techniques is the dislodgment of embolic materials generated during manipulation of the vessel, thereby causing occlusion of the narrower vessels downstream and ischemia or infarct of the organ that the vessel supplies. In 1995, Waksman et al. disclosed that distal embolization is common after directional atherectomy in coronary arteries and saphenous
10 vein grafts. See Waksman et al., *American Heart Journal* 129(3): 430-5 (1995), (this and all other references cited herein are expressly incorporated by reference as if fully set forth in their entirety herein). This study found that distal embolization occurs in 28% (31 out of 111) of the patients undergoing atherectomy. In January 1999, Jordan, Jr. et al. disclosed that treatment of carotid stenosis using percutaneous angioplasty with stenting
15 is associated with more than eight times the rate of microemboli seen using carotid endarterectomy. See Jordan, Jr. et al. *Cardiovascular Surgery* 7(1): 33-8 (1999), incorporated herein by reference. Microemboli, as detected by transcranial Doppler monitoring in this study, have been shown to be a potential cause of stroke. The embolic materials include calcium, intimal debris, atheromatous plaque, thrombi, and/or air.

20 There are a number of devices designed to provide blood filtering for entrapment of vascular emboli. The vast majority of these devices are designed for permanent placement in veins to prevent pulmonary embolism. A temporary venous filter device is disclosed in Bajaj, U.S. Patent No. 5,053,008, incorporated herein by reference. The

Bajaj device is an intracardiac catheter for temporary placement in the pulmonary trunk of a patient predisposed to pulmonary embolism due to, *e.g.*, hip surgery, major trauma, major abdominal or pelvic surgery, or immobilization. The Bajaj device includes an umbrella made from meshwork that traps venous emboli before they reach the lungs.

- 5 This device is designed for venous filtration and is not suitable for arterial use because of the hemodynamic differences between arteries and veins.

There are very few intravascular devices designed for arterial use. Arteries are much more flexible and elastic than veins and, in the arteries, blood flow is pulsatile with large pressure variations between systolic and diastolic flow. These pressure variations
10 cause the artery walls to expand and contract. Blood flow rates in the arteries vary from about 0.1 to 5 L/min. Ginsburg, U.S. Patent No. 4,873,978, discloses an arterial filtering system, which includes a catheter with a strainer device at its distal end. This device is inserted into the vessel downstream from the treatment site and, after treatment, the strainer is collapsed around the entrapped emboli and removed from the body. The
15 Ginsburg device, however, is integral with the catheter, unlike the devices described later herein. Ing. Walter Hengst GmbH & Co, German Patent DE 34 17 738, discloses another arterial filter having a folding linkage system that converts the filter from the collapsed to the expanded state.

Filters mounted to the distal end of guidewires have been proposed for
20 intravascular blood filtration. A majority of these devices include a filter that is attached to a guidewire and is mechanically actuated via struts or a pre-shaped basket that deploys in the vessel. These filters are typically mesh "parachutes" that are attached to the shaft of the wire at the distal end and to wire struts that extend outward in a radial direction at

their proximal end. The radial struts open the proximal end of the filter to the wall of the vessel. Blood flowing through the vessel is forced through the mesh thereby capturing embolic material in the filter.

5 Gilson et al., International Publication No. WO 99/23976 describes a guidewire with a filter slideably mounted thereon. Although the filter is not fixed to the guidewire at a single point, the filter is limited in its range of movement by two stops at the distal end of the guidewire, the stops being relatively closely spaced. Thus, unlike the present invention, in Gilson et al. the filter cannot be removed unless the entire guidewire is removed.

10 The useful *in vivo* time of a guidewire filter will vary, depending upon the type of procedure, the patient, and the blood flow. These factors may contribute to relatively short use time because of, for example, blood coagulation or excessive emboli clogging the filter mesh. Because for existing devices, the guidewire and the filter are integrated into one inseparable device, changing the filter after its useful *in vivo* deployment time
15 has been completed requires the removal and replacement of the guidewire. This change requires time consuming and costly fluoroscopic guidance to reposition the new guidewire and filter.

There is a need in the art for a device that will not require removal and replacement of the guidewire should the *in vivo* useful life of a blood filter be exceeded.
20 The present invention addresses that need by providing a blood cartridge filter that may be used and replaced without requiring the removal of the guidewire.

Summary of the Invention

The present invention provides devices and methods for directing a blood filter into position using a guidewire wherein the blood filter may be deployed and replaced independently of the guidewire. More specifically, a guidewire cartridge filter system is disclosed for capturing embolic material generated during a surgical procedure within a region of interest in an artery or vein.

In accordance with the present invention, the cartridge filter system comprises an elongate member that acts as an advancing mechanism, e.g., a push wire or sheath, having a distal region attached to a filter, e.g., a parachute, basket, or scroll filter. In certain embodiments, the filter may be releasably attached to the elongate member through an interlock, which may comprise, for example, a mechanical interlock or electromechanical interlock. The filter may comprise an expansion frame and a filter material, typically a filter mesh, attached to the expansion frame. The cartridge filter system includes means for engaging the guidewire, such as a wire guide that slideably engages a guidewire. The wire guide may be attached to either or both of the elongate member and the filter. In certain embodiments, the wire guide comprises a ring having an aperture adapted to receive the guidewire. In certain other embodiments, the wire guide comprises a body portion of the elongate member having a longitudinally extending groove adapted to slideably engage the guidewire. The body portion may thus have a C-shaped cross section. Because the wire guide slideably engages the guidewire, the filter may be directed into place by the guidewire, but deployed and retracted independently of the guidewire. The filter can be placed in a collapsed condition to facilitate entry into a vessel and an expanded condition to capture embolic material in the vessel. As used

herein, "advancing mechanism" denotes any elongate member or structure suitable for advancing the filter into position within a vessel while engaging the guidewire through the wire guide. The elongate member could thus be either a wire or a catheter wherein the lumen of the catheter serves as the wire guide. In one embodiment, the elongate
5 member comprises a sheath wherein the lumen of the sheath serves as the wire guide.

Filters suitable for use within the filter system of the present invention are described, for example, in U.S. Patent No. 5,910,154, incorporated herein by reference in its entirety. In one embodiment, the filter is biased to automatically open radially within a blood vessel. In such filters, the expansion frame may comprise a plurality of struts or
10 arms attached to and extending distally from a distal end of the elongate member. The struts are connected to each other at each end and have an intermediate region that is biased to expand radially. Filter mesh is attached typically between the intermediate region such as the midpoint and the distal ends of the struts, thereby defining a substantially hemispherical or conical shaped filter assembly. In embodiments of the
15 invention wherein the elongate member comprises a sheath, a filter biased to automatically open radially may be releasably carried in its collapsed condition within the sheath wherein a mechanical interlock between elongate member and the filter is formed by the friction between the filter and the luminal wall of the sheath.

Other filters suitable for the present invention are not biased to automatically open
20 radially within a blood vessel. In such filters, the elongate member may comprise a sheath containing an inner wire, and the expansion frame includes a plurality of struts attached to the distal end of the sheath. The struts extend distally from the sheath and attach to the distal end of the inner wire that is exposed distally beyond the sheath. At an

intermediate region, the struts are notched or otherwise biased to fold out radially. Filter mesh is attached to the struts between the intermediate region and the distal end of the inner wire. With the sheath fixed, the inner wire is proximally displaced, compressing the struts and causing them to bend or buckle at the intermediate region and move

5 radially outwardly, expanding the filter mesh across the blood vessel. As used herein, "inner wire" means any structure suitable to be slideably disposed within the sheath and stiff enough to compress the struts as the inner wire is proximally displaced with respect to the sheath. The inner wire may thus comprise an inner sheath within which the guidewire is slideably disposed.

10 In certain other embodiments, the filter may comprise a fluid operated filter wherein the expansion frame includes a balloon that inflates to expand the filter into an enlarged condition for use. The construction and use of expansion frames and associated filter mesh have been thoroughly discussed in earlier applications including Barbut et al., U.S. Application Serial No. 08/533,137, filed November 7, 1995, Barbut et al., U.S.

15 Application Serial No. 08/580,223, filed December 28, 1995, Barbut et al., U.S. Application Serial No. 08/584,759, filed January 9, 1996, Barbut et al., U.S. Patent No. 5,769,816, Barbut et al., U.S. Application Serial No. 08/645,762, filed May 14, 1996, and Barbut et al., U.S. Pat. No. 5,662,671, and the contents of each of these prior applications are expressly incorporated herein by reference.

20 The methods of the present invention include prevention of distal embolization during an endovascular procedure to remove emboli and/or foreign bodies such as gas bubbles from blood vessels. The vessels include the coronary artery, aorta, common carotid artery, external and internal carotid arteries, brachiocephalic trunk, middle

cerebral artery, basilar artery, subclavian artery, brachial artery, axillary artery, iliac artery, renal artery, femoral artery, popliteal artery, celiac artery, superior mesenteric artery, inferior mesenteric artery, anterior tibial artery, posterior tibial artery, and all other arteries carrying oxygenated blood. Suitable venous vessels include the superior vena cava, inferior vena cava, external and internal jugular veins, brachiocephalic vein, pulmonary artery, subclavian vein, brachial vein, axillary vein, iliac vein, renal vein, femoral vein, profunda femoris vein, great saphenous vein, portal vein, splenic vein, hepatic vein, and azygous vein.

In a method of using the cartridge filter system, the distal end of the guidewire is inserted through an artery or vein and advanced into or beyond a region of interest, typically a stenotic lesion caused by buildup of atherosclerotic plaque and/or thrombi. The guidewire may be inserted percutaneously, laparoscopically, or through an open surgical incision. In a collapsed condition, the filter and the elongate member are advanced over the guidewire, having the wire guide of the filter cartridge system engaging the guidewire. In one embodiment, the wire guide engages the elongate member at a single discrete location in a monorail fashion such as through a ring structure. If the wire guide includes a body portion of the elongate member having a longitudinally extending groove adapted to slideably engage the guidewire, the body portion engages the guidewire in an over-the-wire fashion wherein the guidewire is slideably disposed within the groove of the body portion. Alternatively, the elongate member may comprise a sheath wherein the guidewire is slideably disposed within the lumen of the sheath in an over-the-wire fashion such that the lumen serves as the wire guide. Regardless of whether the wire guide engages the guidewire in a monorail or an

over-the-wire fashion, the filter is then expanded downstream of the vascular occlusion. If the wire guide engages the guidewire in an over-the-wire fashion, the elongate member may be left in the vessel during the *in vivo* deployment time of the filter because the elongate member and the guidewire are then integrated into a single unit, limiting the interference with further deployment of therapy devices in the vessel. If, however, the wire guide engages the guidewire in a monorail fashion, the elongate member is preferably removed from the filter during the *in vivo* deployment time of the filter to prevent a clinician from having to contend with the independent movement of both the guidewire and the elongate member during the surgical procedure. Preferably, in such embodiments, the elongate member releasably attaches to the filter through a mechanical interlock. After deploying the filter, the mechanical interlock is released to allow the removal of the elongate member.

Should the *in vivo* deployment time of the filter be exceeded, the used filter is retracted from the body and the guidewire. If the filter and elongate member were separated by releasing an interlock, the wire guide on the elongate member must be engaged with the guidewire so that the elongate member may be displaced distally on the guidewire towards the used filter. The interlock would then be re-engaged to connect the elongate member and the used filter together whereupon the elongate member may be retracted to remove the used filter. If the elongate member and the used filter were permanently attached, the elongate member may simply be retracted to remove the used filter. An additional filter and elongate member may then be advanced over the guidewire as described herein. Because the present invention allows the removal and replacement of filters without requiring the removal of the guidewire, the filter system

may be denoted a “cartridge filter” system in that the filter is akin to, for example, a printer cartridge, readily replaceable within the printer. After the stenotic lesion is removed or otherwise treated and an adequate luminal diameter is established, the filter is collapsed and removed, together with the captured embolic debris, from the vessel by withdrawing another elongate member used for retrieval. Alternatively, the filter could be removed by withdrawing the guidewire to remove the entire filter system.

Brief Description of the Drawings

Fig. 1A depicts an embodiment of an elongate member having a filter in a collapsed condition according to the present invention.

Fig. 1B depicts the elongate member of Fig. 1A having the filter in an expanded condition.

Fig. 1C depicts a cross-sectional view through section line C—C of the elongate member depicted in Fig. 1B.

Fig. 1D depicts the elongate member of Fig. 1C having a guidewire received through the wire guide.

Fig. 2A depicts an embodiment of a distal end of the guidewire.

Fig. 2B depicts an alternative embodiment of the distal end of the guidewire.

Fig. 2C depicts another alternative embodiment of the distal end of the guidewire.

Fig. 3A depicts another embodiment of the filter shaped as a parachute.

Fig. 3B depicts another embodiment of the filter shaped as an eggbeater.

Fig. 4A depicts a guidewire inserted across a vascular occlusion.

Fig. 4B depicts a monorail cartridge filter system being deployed across a

vascular occlusion.

Fig. 4C depicts a monorail cartridge filter system wherein the mechanical interlock connecting the elongate member and the filter has been released.

Fig. 4D depicts an over-the-wire cartridge filter system deployed across a
5 vascular occlusion.

Fig. 5A depicts a cartridge filter system wherein the system operate as either an over-the-wire or a monorail system

Fig. 5B depicts a cross-sectional view through section line B—B of the elongate member depicted in Fig. 5A.

10 Fig. 6 depicts a cartridge filter system wherein the elongate member comprises an inner sleeve and wherein the system further includes a capture sheath.

Fig. 7A depicts a guidewire with a distal stop positioned across a vascular lesion.

Fig. 7B depicts a slideable filter, an advancing mechanism, and a capture sheath disposed over the guidewire of Fig. 7A.

15 Fig. 7C depicts the capture sheath crossing the lesion with a filter expanded downstream.

Fig. 7D depicts the guidewire and slideable filter after removal of the capture sheath and advancing mechanism.

20 Fig. 8 depicts an advancing mechanism connected to a slideable filter through a flush contact.

Fig. 9A depicts an advancing mechanism connected to a slideable filter through pivoting claws.

Fig. 9B depicts the opening of the pivoting claws of Fig. 9A.

Fig. 10A depicts an advancing mechanism connected to a slideable filter through a threaded interlock.

Fig. 10B depicts the opening of the threaded interlock of Fig. 10A.

Fig. 11A depicts the slideable filter connected to an advancing mechanism
5 through a mechanical interlock.

Fig. 11B depicts the assembly of Fig. 11A after removal of a capture sheath.

Fig. 11C depicts the assembly of Fig. 11B after rotation of the mechanical interlock.

Fig. 11D depicts the assembly of Fig. 11C after removal of the sheath and
10 advancing mechanism.

Fig. 12A depicts an actuatable stop comprising off-center tubes disposed along a guidewire.

Fig. 12B depicts a distal view of the stop of Fig. 12A.

Fig. 12C depicts insertion of a slideable filter and the stop of Fig. 12A into a
15 vessel.

Fig. 12D depicts the slideable filter and stop of Fig. 12C after removal of the capture sleeve.

Fig. 12E depicts the slideable filter and stop of Fig. 12C before advancement of the alignment sheath.

Fig. 13A depicts another embodiment of an actuatable stop having a slideable filter bearing proximally against the stop.
20

Fig. 13B depicts a capture sheath disposed about and aligning the actuatable stop and filter of Fig. 13A.

Fig. 13C depicts the filter withdrawn proximally over the actuatable stop of Fig. 13B.

Fig. 14A depicts another embodiment of an actuatable stop comprising a slip stop.

Fig. 14B depicts a capture sheath disposed about and aligning the actuatable stop and filter of Fig. 14A.

Fig. 15A depicts a guidewire having a single distal stop.

Fig. 15B depicts a guidewire having proximal and distal stops, wherein the stops are pivoting barbs.

Fig. 15C depicts a guidewire having a distal stop and two proximal stops, wherein the proximal stops comprise pivoting cleats.

Fig. 15D depicts a capture sheath disposed about and aligning the cleats with a filter.

Fig. 15E depicts another embodiment of a capture sheath disposed about and aligning the cleats with a filter.

Fig. 16A depicts an open carriage filter structure.

Fig. 16B depicts a continuous carriage filter structure.

Detailed Description

In a first embodiment, a cartridge filter system for temporary placement in a vessel, either an artery or vein, is provided as depicted in Figs. 1A, 1B, 1C, and 1D. The filter system includes an elongate member 10 having a proximal end, distal region 11, and expandable filter 20 mounted at the distal region. The filter 20 comprises expansion frame 22 and mesh 25 that is welded, adhesive bonded, or otherwise disposed about struts

28 of the expansion frame. Alternatively, the filter comprises a membrane extending from a proximal end to a distal end and having an expandable intermediate region. the proximal end includes segments that extend to the intermediate region and that have gaps or windows in between to allow blood to flow inside the structure. the distal end is a
5 continuous membrane having holes drilled therein to create a filter membrane. Anticoagulants, such as heparin and heparinoids, may be applied to the mesh 25 to reduce thrombi formation. The filter 20 can be collapsed as shown in Fig. 1A to facilitate insertion into a vessel, and thereafter expanded as shown in Fig. 1B. Wire guide 26, which is adapted to slideably engage a guidewire 30, may be included in distal region 11
10 of the elongate member 10. Alternatively, the wire guide 26 may be integral with the filter or with both the filter and the elongate member. In certain embodiments, the wire guide 26 may comprise a ring-shaped structure. A cross-sectional view of the elongate member 10 through section line C—C is depicted in Fig. 1C. The design and construction of a variety of expandable filters suitable for use within the filter cartridge
15 system of the present invention is described in detail in Tsugita et al., U.S. Patent No. 5,910,154.

The filter may be biased to automatically open radially within a blood vessel. In such filters, the struts of the expansion frame may be connected to each other at each end and have an intermediate region that is biased to expand radially as illustrated in Figures
20 1A and 1B. Other filters suitable for the present invention are not biased to automatically open radially within a blood vessel. One embodiment of such a filter, as illustrated in Figure 6, the struts 28 are notched or otherwise biased to fold out radially. At a distal end of the filter, the struts attach to an inner wire 55 whereas the proximal end of the struts

attach to an outer sheath 55. Proximal displacement of the inner wire 55 with respect to the outer sheath 55 causes the struts to fold out radially, thereby expanding the filter mesh 25 across a blood vessel lumen. Alternatively, the filter may be fluid operated as discussed previously.

5 It is to be noted that if the blood filter is biased to automatically open radially within a blood vessel, a restraint is needed to collapse the filter before it is inserted into a vessel lumen. In one embodiment, a sleeve 5 acts as the restraint to collapse the filter 20 as illustrated in Figure 1A. To release the restraint, the sleeve 5 may be retracted from the filter 20 by proximally displacing a wire 6 as illustrated in Figure 1B.

10 To deploy the cartridge filter system of the present invention, the wire guide 26 engages the guidewire 30 having a proximal end and distal end 33. The guidewire 30 is slideably received by elongate member 10 through wire guide 26 as depicted, for example, in Fig. 1D. Different constructions of the distal end 33 of the guidewire 30 are depicted in Figs. 2A, 2B, and 2C. Distal end 33 may assume a substantially linear
15 configuration relative to the proximal end of the guidewire as depicted in Fig. 2A. Alternatively, distal end 33 may assume an angular configuration relative to the proximal end of the guidewire as depicted in Fig. 2A. Distal end 33 may be shaped like a fishhook as depicted in Fig. 2C. The distal region of the guidewire may be constructed of a flexible material to facilitate entry through a region of interest, and preferably is equipped
20 with an atraumatic tip as is known in the art. The embodiments in Figs. 2B and 2C, having a curvilinear design, are particularly useful in achieving access to a complex lesion in a tortuous vessel.

Figs. 3A and 3B depict alternative embodiments of expandable filter 20 mounted

on the distal region of elongate member 10. In Fig. 3A, the filter 20 comprises an expansion frame 22 that is parachute-shaped and mesh 25 that is welded or adhesive bonded to struts 28 of the expansion frame 22. Wire guide 26 is included in the distal region of the elongate member and projects distally from filter 20 for engaging a
5 guidewire. In Fig. 3B, filter 20 comprises an expansion frame 22 that assumes the shape of an eggbeater in its expanded state and wherein struts 28 are compressible.

By way of example, when the cartridge filter system as disclosed herein is intended for use in the aorta, the area of the mesh 25 required for the device is calculated from Bernoulli's equation as described in our earlier applications including Barbut et al.,
10 U.S. Patent No. 5,662,671, Barbut et al., U.S. Application Serial No. 08/553,137, filed November 7, 1995, Barbut et al., U.S. Application Serial No. 08/580,223, filed December 28, 1995, Barbut et al., U.S. Application Serial No. 08/584,759, filed January 9, 1996, Barbut et al., U.S. Application Serial No. 08/640,015, filed April 30, 1996, and Barbut et al., and U.S. Application Serial No. 08/645,762, filed May 14, 1996.

15 The guidewire and slideable filter disclosed herein may be used in the carotid arteries, the coronary arteries, the aorta, and in where temporary filtration is desired. In an embodiment of the cartridge filter system that is to be used in the aorta, the filter material is a mesh 25 with dimensions within the following ranges is desirable: mesh area is 0.004–5 in², more preferably 0.007–4 in², more preferably 0.010–3 in², more
20 preferably 0.015–2 in², more preferably 0.020–1 in², more preferably 0.025–0.076 in²; mesh thickness is 60–280 μm, more preferably 70–270 μm, more preferably 80–260 μm, more preferably 90–250 μm, more preferably 100–250 μm, more preferably 120–230

μm, more preferably 140–210 μm; thread diameter is 30–145 μm, more preferably 40–135 μm, more preferably 50–125 μm, more preferably 60–115 μm, more preferably 70–105 μm, and pore size is 500 μm or less, more preferably 400 μm or less, more preferably 300 μm or less, more preferably 200 μm or less, more preferably 100 μm or less, more preferably 50 μm or less and usually larger than at least a red blood cell. In a preferred embodiment of the invention, mesh area is 2–8 in², mesh thickness is 60–200 μm, thread diameter is 30–100 μm, and pore size is 50–300 μm. In a further preferred embodiment of the invention, mesh area is 3–5 in², mesh thickness is 60–150 μm, thread diameter is 50–80 μm, and pore size is 100–250 μm.

10 In other embodiments, the filter material comprises a thin film laser cut with holes to allow blood flow (not illustrated). Typical dimensions include pore size of 20–500 μm, a thickness of 0.0005–0.003 inches, and area approximately same as for meshes described above .

Once appropriate physical characteristics are determined, suitable mesh 25 can be found among standard meshes known in the art. For example, polyester meshes may be used, such as meshes made by Saati Corporations and Tetko Inc. These are available in sheet form and can be easily cut and formed into a desired shape. In a preferred embodiment, the mesh is welded (*e.g.*, sonic or laser) or sewn into a cone shape. Other meshes known in the art, which have the desired physical characteristics, are also suitable. Anticoagulants, such as heparin and heparinoids, may be applied to the mesh to reduce the chances of blood clotting on the mesh. Anticoagulants other than heparinoids also may be used, *e.g.*, ReoPro (Centocor). The anticoagulant may be painted or sprayed

onto the mesh. A chemical dip comprising the anticoagulant also may be used. Other methods known in the art for applying chemicals to mesh may be used.

The length of the guidewire 30 and the elongate member 10 will generally be between 30 and 300 centimeters, preferably approximately between 50 and 195
5 centimeters. The filter will be capable of expanding to an outer diameter of at least 0.2 centimeters, more preferably at least 0.5 centimeters, more preferably at least 1.0 centimeters, more preferably at least 1.5 centimeters, more preferably at least 2.0 centimeters, more preferably at least 2.5 centimeters, more preferably at least 3.0 centimeters, more preferably at least 3.5 centimeters, more preferably at least 4.0
10 centimeters, more preferably at least 4.5 centimeters, more preferably at least 5.0 centimeters. These ranges cover suitable diameters for both pediatric and adult use. The foregoing ranges are set forth solely for the purpose of illustrating typical device dimensions. The actual dimensions of a device constructed according to the principles of the present invention may obviously vary outside of the listed ranges without departing
15 from those basic principles.

In use, as depicted in Fig. 4A, guidewire 30 may be inserted percutaneously through a peripheral artery or vein and advanced typically in the direction of blood flow. However, guidewire 30 may be inserted and advanced in a direction opposite the blood flow, *e.g.*, retrograde through the descending aorta to reach the coronary artery. Distal
20 end 33 of the guidewire 30 is passed through occluding lesion 100, typically an atheromatous plaque, and positioned distal to the occlusion. Elongate member 10 of Fig. 1A is inserted over the proximal end of guidewire 30 through wire guide 26, and advanced distally until filter 20 is positioned distal to plaque 100 as depicted in Fig. 4B.

By having wire guide 26 engage the guidewire 30, the filter 20 and the elongate member 10 can be easily steered intravascularly to reach the region of interest. Filter 20 is expanded to capture embolic material, such as calcium, thrombi, plaque, and/or tissue debris. The useful *in vivo* life of filter 20 depends greatly on the type of medical procedure being performed, the condition of the patient (such as whether the patient is receiving an anticoagulant), and volume of blood flow. Although current filters can be deployed for relatively long periods (upwards of 60 minutes), it is possible that current filters will have shorter useful *in vivo* deployment times for the reasons noted above. Should the useful *in vivo* life of filter 20 be exceeded, filter 20 must be replaced by an unused filter. Unlike prior art systems in which the filter was integrated with the guidewire, in the present invention, filter 20 and elongate member 10 may be retracted from the body and guidewire 30 without requiring the removal of guidewire 30. An unused filter 20 and elongate member 10 may then be inserted over the proximal end of guidewire 30 through a wire guide 26, and advanced distally until filter 20 is positioned distal to plaque 100 similarly as depicted in Fig. 4B.

As illustrated in Figure 4B, the wire guide 26 may engage the guidewire 30 at a single discrete location. Suitable wire guides 26 that engage the guidewire at a discrete location may comprise, for example, a ring or similar structure. Such embodiments of the cartridge filter system may be denoted “partially-threaded” or monorail systems because, proximal to the wire guide 26, the guidewire 30 and the elongate member 10 are separate and independent from one another. Other medical devices having monorail construction are known in the art. Note that proximal to the wire guide, a clinician must contend with two separate and independent structures within the vessel lumen. This can

make the insertion of additional therapy devices into the vessel lumen difficult. For example, a therapy device, such as an angioplasty balloon, will typically engage the guidewire to assist positioning the therapy device in the vessel. As the therapy device is displaced along the guidewire, it may cause the elongate member to injure the vessel lumen.

To prevent such injury, the filter and elongate member may be releasably attached through an interlock in a monorail embodiment of the invention. As illustrated in Figure 4C, the interlock may comprise a mechanical interlock having a threaded portion 9 at the distal end of the elongate member 10 adapted to engage a threaded portion 8 attached to the filter 20. After the filter 20 has been expanded to cover the vessel lumen, the elongate member 10 is rotated to release the mechanical interlock by unthreading the threaded portions 8 and 9. Note that the filter 20 is then retained only by the guidewire 30. To assist the retention of the filter 20 along the guidewire, the guidewire may have a stop 60 to prevent further distal displacement of the filter. In such an embodiment, the filter is free, however, to displace proximally. The pressure from the blood flow and the tension provided by the expansion of the filter against the walls of the vessel lumen will tend to prevent proximal displacement. Although such forces will tend to prevent proximal displacement, it may be beneficial during some procedures to allow a small amount of proximal displacement when necessary.

As used herein, "elongate member" denotes any structure suitable for advancing filter 20 into position within a vessel while engaging guidewire 30 through a wire guide 26. Thus elongate member 10 may comprise, of course, a wire. Alternatively, elongate member 10 may comprise a catheter such as a balloon catheter suitable for angioplasty.

If elongate member 10 comprises a catheter, the lumen of the catheter may serve as the wire guide 26. In such an embodiment, elongate member 10 slideably engages guidewire 30 in an “over-the-wire” manner similar to, for example, the manner in which a single lumen catheter is threaded over a guidewire in neuroradiological procedures. Turning now to Figure 4D, an over-the-wire cartridge filter system is illustrated. Elongate member 10 comprises a catheter or sleeve 35 wherein the lumen 40 of the catheter 35 serves as the wire guide 26. The expansion frame 22 of filter 20 attaches to the catheter 35 along the catheter wall portion 42. Unlike the monorail system illustrated in Figure 4B, a clinician threading additional devices into the blood vessel in which an over-the-wire cartridge filter system is deployed will not have to contend with two independent structures within the blood vessel lumen. Inspection of the monorail cartridge filter system illustrated in Figure 4B reveals that proximal to the filter 20, the guidewire 30 and elongate member 10 are independent of one another, potentially hampering the deployment of additional devices within the blood vessel. Nevertheless, monorail or partially-threaded systems possess advantages over an over-the-wire system (that may be denoted as “fully-threaded”). For example, in angioplasty procedures or the like, the guidewire 30 must be relatively long to extend from vessels within a patient’s leg to the heart. If the proximal portion of the guidewire 30 that extends outside the patient’s body is relatively short, there comes a point at which, as the elongate member 10 is retracted from the body, the elongate member 10 will entirely cover this external proximal portion of the guidewire 30 (in an over-the-wire cartridge filter system). The clinician would then no longer be able to maintain the position of the guidewire 30. Thus, as is known in other medical procedures, over-the-wire medical devices require relatively long

proximal transfer portions external to a patient's body, causing inconvenience during catheterization procedures.

The present invention includes over-the-wire filter cartridge system embodiments that do not require the relatively long proximal transfer portions of prior art over-the-wire systems. For example, in Figure 5A and 5B, an embodiment of such a filter cartridge system is illustrated. Elongate member 10 may include a ring-shaped wire guide 26 that attaches to the expansion frame 22 of filter 20 (filter 20 only partly illustrated). Elongate member 10 also includes a body portion 46 having a longitudinally extending groove 45 adapted to slideably engage wire guide 30. In one embodiment, groove 45 is shaped such that body portion 46 has a C-shaped cross section as illustrated in Figure 5B. The elongate member 10 is constructed of a suitably flexible material such that a clinician may force guidewire 30 into the groove 46 by forcing apart arms 47 and 48 of the "C" formed by groove 46. The guidewire 30 would then be held within groove 46 by arms 47 and 48. Outside the body, the elongate member 10 and the guidewire 30 may be kept separate, eliminating the need for a long proximal transfer portion outside the patient's body. Within a vessel, however, the system of Figures 5A and 5B will operate as an over-the-wire system. As the filter 20 and elongate member 10 are retracted from the guidewire 30 and the patient's body, the guidewire 30 may be separated from the elongate member 10 by pulling apart the already separated portions of elongate member 10 and guidewire 30. The resulting tension flexes arms 47 and 48 outwardly, allowing the guidewire 30 to be removed from the groove 45.

Although the groove 45 slideably engages the guidewire 30, it is to be noted that (particularly when body portion 46 has a C-shaped cross section) the guidewire 30 may

not be entirely circumferentially surrounded by elongate member 10 as is the case in ordinary over-the-wire systems (such as illustrated in Figure 4c). To provide full circumferential support around guidewire 30, elongate member 10 may have one or more spiral portions 47 wherein the elongate member spirals about guidewire 30 such that spiral portion 47 resembles coils of a spring. Note that should the elongate member 10 include the spiral portions 47, as the filter 20 and elongate member 10 are retracted from the guidewire 30, the clinician will unravel the spring portion 47 to separate it from the guidewire 30. Conversely, as the elongate member 10 is being advanced along guidewire 30, the clinician must ravel spiral portion 47 about the guidewire 30 to continue deployment of a filter.

Regardless of whether the cartridge system is an over-the-wire or a monorail system, one of ordinary skill in the art will appreciate that there are a number of ways to actuate the filter of the present invention. For example, if the filter is biased to automatically open radially within a blood vessel, the cartridge filter system may be contained within a catheter or sheath 5 as illustrated in Figure 1A. As the elongate member and filter are advanced beyond the sheath 5, the filter will automatically expand radially within the vessel because of the pre-existing bias within the filter as illustrated in Figure 1B. Alternatively, the filter may be fluid operated wherein the filter contains a balloon that expands to expand the filter. In addition, the filter may be mechanically actuated by the clinician.

Turning now to Figure 6, a mechanically actuated cartridge filter system is illustrated. In such filters, the elongate member 10 may comprise a sheath or catheter 50 containing an inner wire 55 wherein the expansion frame 22 includes a plurality of struts

28 attached to the distal end of the sheath 50. The struts 28 extend distally from the sheath 50 and attach to the distal end of the inner wire 55 that is distally exposed beyond the sheath. At an intermediate region, the struts 28 are notched or otherwise biased to fold out radially. Filter mesh 25 is attached to the struts 28 between the intermediate
5 region and the distal end of the inner sheath 55. To open the filter 20, the sheath 50 is fixed in position, and the inner wire 55 is proximally displaced, compressing the struts 28 and causing them to bend or buckle at the intermediate region and move radially outwardly, expanding the filter mesh 25 across the blood vessel. It is to be noted that the guidewire 30 may have a stop 60 formed to assist the positioning and deployment of the
10 filter 20 along the guidewire 30.

As used herein, "inner wire" means any structure suitable to be slideably disposed within the sheath 50 and stiff enough to compress the struts 28 as the inner wire 55 is proximally displaced with respect to the sheath 50. Thus, as illustrated in Figure 6, the inner wire 55 may comprise an inner sheath 55 that slideably contains the guidewire 30
15 within a lumen of the inner sheath. Note that the inner sheath 55 and the sheath 50 may each possess a body portion having a longitudinally extending slit therein (not illustrated). Within both the inner sheath 55 and the sheath 50, the combination of the slit and the lumen would therefore comprise the longitudinally extending groove already described. Therefore, the cartridge filter system illustrated in Figure 6 could be advanced
20 within a blood vessel in an over-the-wire fashion yet not require a relatively long proximal transfer portion as described with respect to the embodiment of the cartridge filter system illustrated in Figures 5A and 5B.

Another method for deploying a slideable filter along a guidewire is shown in

Figs. 7A – 7D. According to this method, guidewire 30 is first positioned across lesion 100 within vessel 101. Guidewire 30 may include a distal stop 102. Filter 110, having proximal end 111 and distal end 112, is then advanced along guidewire 30. This step of advancement is typically performed with capture sheath 105 disposed about filter 110.

5 Advancement may also be accomplished using an advancing mechanism 120 having distal end 121 that bears against proximal end 111 of filter 110. Alternatively, the static friction between filter 110 and sheath 105 may be adequate to advance the filter along guidewire 30, in which case sheath 105 is the advancing mechanism. Once filter 110 is positioned downstream of lesion 100, capture sheath 105 is withdrawn, allowing the filter

10 to expand as depicted in Fig. 7C. Further distal advancement of filter 110 is prohibited by frictional engagement of filter 110 by the vessel lumen or by stop 102 when present. Alternatively, filter 110 may be equipped with an actuatable locking mechanism that engages guidewire 30 when the filter is properly positioned. After expansion of filter 110, capture sheath 105 and advancing mechanism 120 are withdrawn from the region of

15 interest as shown in Fig. 7D, and removed from the patient's vessel.

In certain embodiments, the advancing mechanism bears against proximal end 111 of filter 110, but is not otherwise connected. In other embodiments as shown in Fig. 8, advancing mechanism 125, having distal end 126, is coupled through flush contact interlock 127 to proximal end 111 of filter 110. In this case, the interlock is activated by

20 magnetic or electromagnetic force and is releasable. Figs. 9A and 9B show an alternative mechanical interlock. In Fig. 9A, pivoting claws 130 are mounted at the distal end of advancing mechanism 125. The distal end of each claw 130 is adapted to engage recess 131 disposed circumferentially about proximal end 111 of filter 110. Claws 130 are

maintained in contact with recess 131 by the action of locking sheath 133 that bears circumferentially against claws 130. When capture sheath 105 and locking sheath 133 are withdrawn as depicted in Fig. 9B, claws 130 pivot out of engagement, thereby releasing filter 110.

5 Another mechanical interlock is shown in Figs. 10A and 10B. Fig. 10A shows a threaded interlock between threaded screw 136 mounted on proximal end 111 of filter 110. The screw engages coupling 135 having a threaded portion adapted to receive screw 136. Fig. 10B depicts disengagement of coupling 135 from screw 136 to permit removal of advancing mechanism 125 and capture sheath 105 from the patient's vessel. In order
10 to disengage the coupling from the screw it may be necessary to have a rotational lock on the filter, so that the coupling can be rotated while the filter remains fixed.

A further mechanical interlock is shown in Figs. 11A – 11D. Fig. 11A shows first hook 140 mounted at the distal end of advancing mechanism 125. Second hook 141 is mounted at proximal end 111 of filter 110, and is adapted to engage first hook 140.
15 Engagement of hooks 140 and 141 is dependent upon proper rotational alignment of the hooks. This alignment is maintained so long as sheath 105 surrounds the interlock. Fig. 11B shows the interlock after placement within a vessel and removal of sheath 105. As depicted in Fig. 11C rotation of hook 140 disengages the interlock. Advancing mechanism 125 and sheath 105 are then removed from the region of interest and from the
20 patient's vessel as shown in Fig. 11D. In addition to the detachable interlock mechanisms discussed above, a number of additional mechanisms have been disclosed in U.S. Patent. Nos. 5,312,415, 5,108,407, 5,891,130, 5,250,071, 5,925,059, 5,800,455, 5,800,543, 5,725,546, 5,350,397, 5,690,671, 5,944,733, 5,814,062, and 5,669,905, all of

which are expressly incorporated herein by reference in their entirety. It will be understood that any of the interlocks disclosed in any of these patents may be used in the present invention.

As noted above, one or more distal and/or proximal stops may be placed along the
5 guidewire. These stops may be pre-mounted, installed during a procedure, or integral with the filter and simultaneously inserted therewith. An actuatable stop is shown in Figs. 12A – 12E. Referring to Fig. 12A, the proximal stop is comprised of off-centered tubes, shown here as first tube 145, second tube 146, and biasing element 147 connecting the first and second tubes. When misaligned as shown in Fig. 12A, first and second tubes
10 145 and 146, respectively, pinch and frictionally engage guidewire 30 as shown in Fig. 12B. In use, this slideable stop can be employed proximal of the filter as shown in Fig. 12C. Sheath 105 contains advancing mechanism 125, an actuatable stop including first and second tubes 145 and 146 coupled through biasing element 147, and filter 110. Sheath 105 forces first and second tubes 145 and 146 into near coaxial alignment, thereby
15 permitting the stop to slide over guidewire 30. This assembly is advanced across lesion 100 until the filter reaches optional distal stop 102. The filter and proximal stop are then released from sheath 105 as depicted in Fig. 12D, the stop engaging the guidewire. Sheath 105 and advancing mechanism 125 are then removed from the patient's vessel. After performance of an endoluminal procedure (*e.g.*, angioplasty, stent deployment,
20 angiography, atherectomy), the filter and stop are retrieved by sheath 150 as depicted in Fig. 12E. Sheath 150 first captures first and second tubes of the stop and forces them into alignment against the action of biasing element 147. In this manner, the stop is de-actuated and again slides over guidewire 30. Sheath 150 then captures filter 110 that

bears against optional stop 102 during advancement of sheath 150 over filter 110. The entire assembly, including sheath 150, filter 110, and the proximal stop, are then removed from the patient's vessel.

In another embodiment, a pivoting proximal stop is used as shown in Figs. 13A –
5 13C. Referring to Fig. 13A, the proximal stop is comprised of tapered proximal section 156 and flat distal section 155, the tapered proximal section allowing a filter to pass distally when advanced over the stop. Proximal section 156 has lumen 157 adapted to receive guidewire 30. Section 155 lies in a plane substantially perpendicular to the axis of lumen 157. In this manner, the proximal stop pivots and frictionally engages
10 guidewire 30 when proximal end 111 of filter 110 bears against section 155. Filter 110 is retrieved and withdrawn over the stop as shown in Fig. 13B. Sheath 105, optionally a stepped sheath as depicted in Fig. 15B, aligns the stop with the opening at the proximal end 111 of filter 110, permitting the filter to pass proximally over the stop as shown in Fig. 13C.

In another embodiment, a slip stop is used as the proximal stop as depicted in
15 Figs. 14A and 14B. Slip stop 160 comprises a tubular segment having open distal end 162 and tapered proximal end 161. Guidewire 30 passes smoothly through proximal end 161 when distal end 162 is centered about guidewire 30. However, when stop 160 becomes misaligned, as shown in Fig. 14A, proximal end 161 pinches and frictionally
20 engages guidewire 30, preventing proximal advancement of filter 110. To retrieve filter 110, sheath 105, optionally a stepped sheath as shown, is advanced distally over stop 160 and filter 110, thereby aligning slip stop 160 with the opening at proximal end 111 of filter 110, as shown in Fig. 14B.

Fig. 15A shows a guidewire having one distal stop 102. Fig. 15B shows a guidewire having distal stop 102 and proximal stop 165. Proximal stop 165 may be mounted on a pivot about its mid-point, thereby allowing a filter to pass proximal to distal, and later be retrieved distal to proximal, provided sufficient force is applied to pivot the stop. Fig. 15C shows two proximal stops 166 and 167, each comprising a plurality of pivoting cleats 168 attached to housing 169 that engages guidewire 30. It will be understood that any number of proximal and distal stops may be employed, including 1, 2, 3, 4, 5, 6, 7, or any other desired number depending on the procedure. Fig. 15D shows retrieval of filter 110. Sheath 105 restrains cleats 168 to allow passage of proximal end 111 of filter 110 over the cleats. In certain embodiments, it may be desirable for sheath 105 to include a sharp step, shown as numeral 170 in Fig. 15E. This sheath will maintain closure of cleats 168 until the cleats are guided within proximal end 111 of filter 110, permitting removal of the filter over the cleats.

The sliding filter as disclosed herein may be constructed with an open carriage as shown in Fig. 16A or a continuous carriage as shown in Fig. 16B. Referring to Fig. 16A, a plurality of struts 181 join proximal end 111 to distal end 112. Filter 110 is disposed about a portion of struts 181, either over or under the struts. Struts 181 buckle radially outward when proximal end 111 and distal end 112 are forced together. In certain embodiments, distal end 112 will include a tapered edge as shown in Fig. 16A. Fig. 16B depicts a continuous carriage extending from proximal end 111 to distal end 112, and terminating in a tapered distal edge. Sliding ring 180 may be incorporated distal or proximal. Struts 181 are connected at a first end to carriage 182 and at a second end to sliding ring 180. Struts 181 buckle radially outward when sliding ring 180 and carriage

182 are forced together.

Although the foregoing invention has, for the purposes of clarity and understanding, been described in some detail by way of illustration and example, it will be obvious that certain changes and modifications may be practiced that will still fall
5 within the scope of the appended claims. Moreover, it will be understood that each and every feature described for any given embodiment or in any reference incorporated herein, can be combined with any of the other embodiments described herein.

What is claimed is:

1. A method for protecting a patient during an endoluminal procedure,
comprising the steps of:
 - advancing a guidewire into a region of interest within a vessel;
 - 5 advancing a filter along the guidewire by operating an advancing
mechanism associated with the filter;
 - expanding the filter within the region of interest; and
 - removing the advancing mechanism from the region of interest.
2. The method of claim 1, wherein the filter is placed on a proximal end of
10 the guidewire after the step of advancing the guidewire into the region of interest within
the vessel.
3. The method of claim 2, wherein the filter is placed on a proximal end of
the guidewire after performing a first endoluminal procedure.
4. The method of claim 1, wherein the step of expanding the filter within the
15 region of interest is performed after the step of removing the advancing mechanism from
the region of interest.
5. The method of claim 1, wherein the advancing mechanism is an elongate
member, the elongate member having a distal region associated with the filter.

6. The method of claim 5, wherein the elongate member engages the guidewire.
7. The method of claim 5, wherein the elongate member is attached to the filter.
- 5 8. The method of claim 7, wherein the attachment is a releasable interlock.
9. The method of claim 8, further comprising the step of releasing the interlock.
10. The method of claim 1, further comprising the step of withdrawing the advancing mechanism from the region of interest.
- 10 11. The method of claim 1, wherein the filter has a wire guide engaging the guidewire.
12. The method of claim 1, wherein the filter is expanded downstream of the region of interest.
13. The method of claim 5, wherein the elongate member is a push wire.
- 15 14. The method of claim 5, wherein the elongate member is a catheter.

15. The method of claim 1, wherein the advancing mechanism is a wire that extends through a lumen of the guidewire to the distal end of the guidewire, then in a proximal direction to a point of attachment to the filter.
16. The method of claim 15, further comprising the step of pulling the wire to
5 advance the filter distally along the guidewire.
17. The method of claim 5, wherein the elongate member is a tubular sheath.
18. The method of claim 18, wherein the tubular sheath has a lumen that contains and frictionally engages an filter.
19. The method of claim 18, further comprising a second elongate member
10 disposed within the tubular sheath and having a distal end operatively associated with the filter.
20. The method of claim 18, further comprising the step of withdrawing the tubular sheath from the filter and releasing the filter.
21. The method of claim 20, wherein the guidewire further comprises a
15 proximal stop, and wherein the filter is released by withdrawing the tubular sheath until the filter bears against the proximal stop.

22. The method of claim 1, wherein the advancing step continues until a distal stop on the guidewire engages the filter.
23. The method of claim 22, wherein the guidewire further comprises a proximal stop located proximal to the distal stop.
- 5 24. The method of claim 23, wherein the proximal stop is actuatable between a retracted condition and a deployed condition, the retracted condition permitting proximal displacement of the filter with respect to the proximal stop, the deployed condition preventing proximal displacement of the filter with respect to the proximal stop, wherein the advancing step is performed with the proximal stop in its retracted
10 condition and the releasing step is performed with the proximal stop in its deployed condition.
25. The method of claim 23, wherein the guidewire further comprises a second proximal stop located proximal to the distal stop.
26. The method of claim 23, wherein the proximal stop does not allow the
15 filter to move proximal of the proximal stop.
27. The method of claim 1, further comprising the step of withdrawing the filter.

28. The method of claim 23, wherein the proximal stop is mounted on the guidewire.
29. The method of claim 23, wherein the proximal stop is slideable on the guidewire, and wherein the step of advancing the filter includes the step of advancing the proximal stop to the region of interest.
30. The method of claim 23, wherein the proximal stop is integral with the filter.
31. The method of claim 8, further comprising the steps of:
engaging the interlock with an elongate member; and
withdrawing the elongate member, interlock, and filter.
32. The method of claim 31, further comprising the step of advancing a capture sheath over the filter, wherein the step of withdrawing the elongate member, interlock, and filter includes withdrawing the capture sheath.
33. The method of claim 32, further comprising the steps of:
advancing a second filter over the guidewire; and
expanding the second filter within the region of interest.

34. The method of claim 1, further comprising the steps of:
advancing a capture sheath over the filter; and
withdrawing the capture sheath and filter.
35. The method of claim 34, wherein the filter bears against a stop as the
5 capture sheath advances over the filter.
36. The method of claim 34, further comprising the steps of:
advancing a second filter over the guidewire; and
expanding the second filter within the region of interest.
37. The method of claim 1, further comprising a sheath slideably disposed
10 about the filter.
38. The method of claim 1, wherein the filter further comprises a locking
mechanism that is operable to engage the guidewire and is releasable to allow the filter to
slide along the guidewire.
39. The method of claim 38, further comprising the step of locking the filter.
40. The method of claim 39, further comprising the step of advancing a sheath
15 over the filter.

41. The method of claim 40, further comprising the step of unlocking the filter.
42. The method of claim 41, further comprising the step of withdrawing the sheath and the filter.
- 5 43. The method of claim 1, wherein the vessel is a carotid artery.
44. The method of claim 1, wherein the vessel is a coronary artery.
45. The method of claim 1, wherein the vessel is an aorta.
46. The method of claim 1, wherein the filter comprises a mesh disposed about a plurality of struts.
- 10 47. The method of claim 46, wherein the mesh is bonded to the inside of the struts.
48. The method of claim 46, wherein the mesh is bonded to the outside of the struts.
49. The method of claim 1, wherein the filter comprises a carriage having one
15 or more openings in a proximal end, an expandable intermediate region, and a distal end with holes for filtering blood.

50. The method of claim 1, wherein the filter comprises a thin film with laser cut holes.

51. A filter system comprising:
a guidewire;
5 an advancing mechanism; and
a filter releasably attached to the advancing mechanism, and being adapted to slideably engage the guidewire.

52. The filter system of claim 51, wherein the advancing mechanism is an elongate member.

10 53. The filter system of claim 52, wherein the elongate member slideably engages the guidewire.

54. The filter system of claim 53, wherein the elongate member is a push wire.

55. The filter system of claim 53, wherein the elongate member is a catheter.

56. The filter system of claim 53, wherein the elongate member is a capture
15 sheath.

57. The filter system of claim 51, wherein the filter is attached to the advancing mechanism through a releasable interlock.

58. The filter system of claim 57, wherein the releasable interlock is a magnetic interlock.

59. A method for protecting a patient during an endoluminal procedure, comprising the steps of:

5 advancing a guidewire having a distal stop into a region of interest within a vessel;

 operating an advancing mechanism to guide a filter along the guidewire to the region of interest; and

 expanding the filter.

10 60. The method of claim 59, wherein the advancing mechanism is an elongate member.

61. The method of claim 59, wherein the elongate member is a push wire.

62. The method of claim 60, wherein the elongate member is a catheter.

63. The method of claim 17, wherein the elongate member is a capture sheath.

64. A filter system, comprising:
a guidewire;
an advancing mechanism having a distal region, the advancing mechanism adapted to operate with the guidewire; and
- 5 an filter releasably attached to the distal region of the advancing mechanism, the filter being attached to the advancing mechanism through a releasable interlock and being adapted to slideably engage the guidewire.
65. The filter system of claim 64, wherein the advancing mechanism is an elongate member.
- 10 66. The filter system of claim 65, wherein the elongate member slideably engages the guidewire.
67. The filter system of claim 66, wherein the elongate member is a push wire.
68. The filter system of claim 66, wherein the elongate member is a catheter.
69. The filter system of claim 66, wherein the elongate member is a capture
- 15 sheath.
70. The filter system of claim 64, wherein the releasable interlock is a magnetic interlock.

71. The filter system of claim 64, wherein the releasable interlock is an electromagnetic interlock.

72. The filter system of claim 64, wherein the interlock is a mechanical interlock.

5 73. The filter system of claim 72, wherein the mechanical interlock comprises a threaded portion on the elongate member and a threaded portion on the filter.

74. The filter system of claim 72, wherein the mechanical interlock comprises first and second hooks and a sheath surrounding the hooks, wherein the hooks remain engaged while within the sheath, and wherein, during use, the sheath is withdrawn and
10 the first hook is rotated out of engagement to release the filter.

75. The filter system of claim 72, wherein the mechanical interlock comprises a plurality of claws mounted at the distal end of the elongate member and a recess on the filter adapted to engage the claws.

76. The filter system of claim 81, further comprising a sheath disposed
15 circumferentially about the claws and that maintains engagement of the claws within the recess.

77. The filter system of claim 70, wherein the guidewire has a distal stop adapted to engage the filter and prevent further distal movement of the filter relative to the guidewire.

78. The filter system of claim 77, wherein the guidewire further comprises a proximal stop proximally located with respect to the distal stop.

79. The filter system of claim 77, further comprising a proximal stop adapted to slide along the guidewire and to lock at a region of interest, wherein the proximal stop is adapted to engage the filter and prevent the filter from passing the stop in a proximal direction.

80. The filter system of claim 79, wherein the proximal stop comprises first and second tubes connected by a biasing element that causes the tubes to be non-coaxial.

81. The filter system of claim 80, wherein the first and second tubes are held coaxial by a sheath surrounding the tubes and exerting a force against the biasing element.

82. The filter system of claim 79, wherein the proximal stop comprises a pivoting element that slides while aligned with the guidewire and pivots out of alignment when engaged by the filter.

83. The filter system of claim 82, wherein the pivoting stop is a slip stop.

84. The filter system of claim 79, wherein the proximal stop is carried within the filter.

85. The filter system of claim 78, wherein the proximal stop does not allow
5 the filter to move proximal of the proximal stop.

86. The filter system of claim 78, wherein the proximal stop is actuatable between a retracted condition and a deployed condition, the retracted condition permitting proximal displacement of the filter with respect to the proximal stop, the deployed condition preventing proximal displacement of the filter with respect to the
10 proximal stop.

87. The filter system of claim 78, wherein the proximal stop is a barb that allows the filter to pass distally, and is operable to allow the filter to pass proximally.

88. The filter system of claim 78, wherein the proximal stop is a pivoting one-
way cleat that allows the filter to pass distally, and is operable to allow the filter to pass
15 proximally.

89. The filter system of claim 88, wherein the proximal stop is operated by passing a sheath over the proximal stop.

90. The filter system of claim 64, further comprising a sheath slideably disposed about the filter.

91. The filter system of claim 64, wherein the filter further comprises a locking mechanism that is operable to engage the guidewire and is releasable to allow the
5 filter to slide along the guidewire.

92. The filter system of claim 64, wherein the filter comprises a mesh disposed about a plurality of struts.

93. The filter system of claim 92, wherein the mesh is bonded to the inside of the struts.

10 94. The filter system of claim 92, wherein the mesh is bonded to the outside of the struts.

95. The filter system of claim 64, wherein the filter comprises a carriage having one or more openings in a proximal end, an expandable intermediate region, and a distal end with holes for filtering blood.

15 96. The filter system of claim 64, wherein the filter comprises an open carriage.

97. The filter system of claim 64, wherein the filter comprises a continuous carriage.
98. The filter system of claim 64, wherein the filter is a parachute filter.
99. The filter system of claim 97, further comprising a sliding ring disposed
5 circumferentially about the continuous carriage.
100. A method for protecting a patient during an endoluminal procedure,
comprising the steps of:
- advancing a guidewire having a distal stop into a region of interest within
a vessel;
- 10 operating an advancing mechanism to guide a filter along the guidewire
until the filter bears against the distal stop; and
- expanding the filter within the region of interest.
101. The method of claim 100, wherein the advancing mechanism is an
elongate member.
- 15 102. The method of claim 101, wherein the elongate member is a push wire.
103. The method of claim 101, wherein the elongate member is a catheter.

104. The method of claim 101, wherein the elongate member is a capture sheath.

105. A filter system, comprising:

a guidewire;

5 an elongate member having a distal region, the elongate member adapted to slideably engage the guidewire through a longitudinally extending groove in a body portion of the elongate member; and

an expandable filter attached to the distal region of the elongate member, the expandable filter slideably engaging the guidewire.

10 106. The filter system of claim 105, wherein the filter further comprises a wire guide that engages the guidewire.

107. The filter system of claim 105, wherein the elongate member is a push wire.

108. The filter system of claim 105, wherein the elongate member is a catheter.

15 109. The filter system of claim 105, wherein the elongate member is a capture sheath.

110. The filter system of claim 105, wherein said expandable filter comprises a plurality of struts and a mesh disposed about the struts.

111. The filter system of claim 105, wherein the body portion has a C-shaped cross section.

5 112. The filter system of claim 111, wherein the elongate member further comprises at least one spiral-shaped region, the spiral-shaped region being adapted to coil about the guidewire.

113. The filter system of claim 112, wherein the wire guide comprises a ring-shaped structure.

10 114. The filter system of claim 105, wherein the filter has a proximal end, a distal end, and a tapered distal edge.

115. The filter system of claim 105, further comprising a sheath slideably disposed about the filter.

15 116. The filter system of claim 105, wherein the expandable filter is attached to the elongate member through a releasable interlock.

117. The filter system of claim 116, wherein the releasable interlock is a mechanical interlock.

118. The filter system of claim 117, wherein the mechanical interlock comprises a threaded portion on the elongate member adapted to threadably engage a matching threaded portion on the expandable filter.

119. The filter system of claim 116, wherein the releasable interlock is a
5 magnetic interlock.

120. The filter system of claim 116, wherein the releasable interlock is an electromagnetic interlock.

121. The filter system of claim 117, wherein the mechanical interlock comprises first and second hooks and a sheath surrounding the hooks, wherein the hooks
10 remain engaged while within the sheath, and wherein, during use, the sheath is withdrawn and the first hook is rotated out of engagement to release the filter.

122. A method for protecting a patient during an endoluminal procedure, comprising the steps of:

providing a guidewire and an elongate member having a distal region, the elongate member adapted to slideably engage the guidewire through a longitudinally
5 extending groove in a body portion of the elongate member, the elongate member further comprising an expandable filter attached to the distal region of the elongate member, the expandable filter slideably engaging the guidewire;

advancing a guidewire having a distal stop into a region of interest within
a vessel;

10 advancing the elongate member over the guidewire, the elongate member engaging the guidewire through the longitudinally extending groove; and
expanding the filter within the region of interest.

123. The method of claim 122, wherein the filter further comprises a wire guide that engages the guidewire.

15 124. The method of claim 122, wherein the elongate member is a push wire.

125. The method of claim 122, wherein the elongate member is a catheter.

126. The method of claim 122, wherein the elongate member is a capture sheath.

127. The method of claim 122, further comprising the steps of:
withdrawing the filter; and
disengaging the guidewire from the longitudinally extending groove of the
elongate member at a position outside of a patient's body.
- 5 128. The method of claim 122, further comprising the step of advancing an
endoluminal therapeutic device over the guidewire.
129. The method of claim 128, wherein the therapeutic device is an angioplasty
catheter.
130. The method of claim 128, wherein the therapeutic device is a stent
10 deployment catheter.
131. The method of claim 128, wherein the therapeutic device is an
atherectomy catheter.
132. The method of claim 128, wherein the therapeutic device is advanced over
the elongate member.
- 15 133. The method of claim 122, further comprising the step of withdrawing the
filter from the region of interest.

134. The method of claim 133, further comprising the step of advancing a second filter to the region of interest and expanding the second filter.

135. The method of claim 32, wherein the capture sheath further comprises aspiration capabilities, and wherein the method further comprises the step of aspirating
5 blood and emboli from the region of interest.

136. The method of claim 34, wherein the capture sheath further comprises aspiration capabilities, and wherein the method further comprises the step of aspirating blood and emboli from the region of interest.

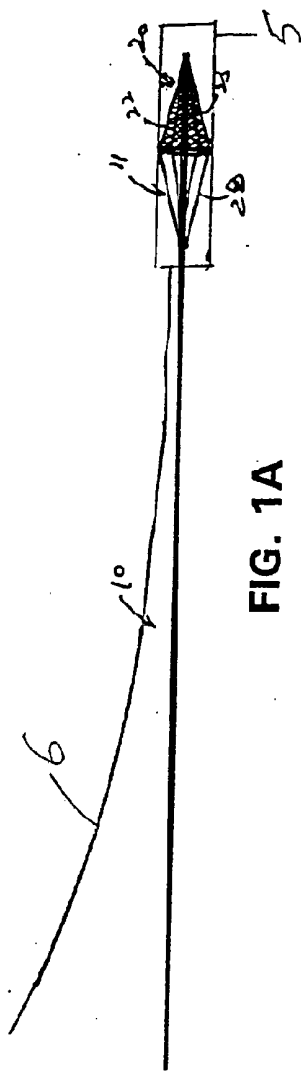

FIG. 1A

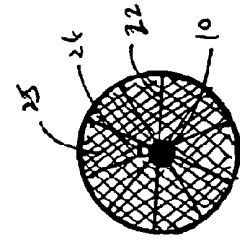

FIG. 1C

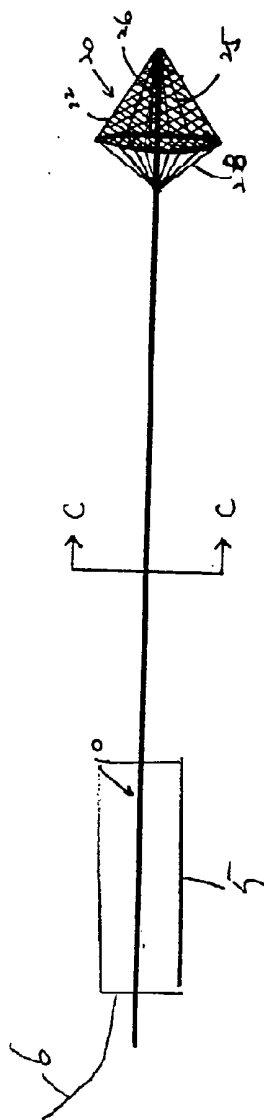

FIG. 1B

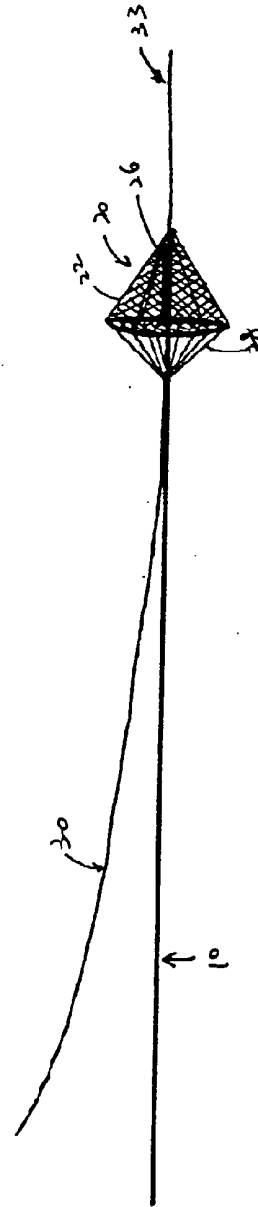

FIG. 1D



FIG. 2A



FIG. 2B



FIG. 2C

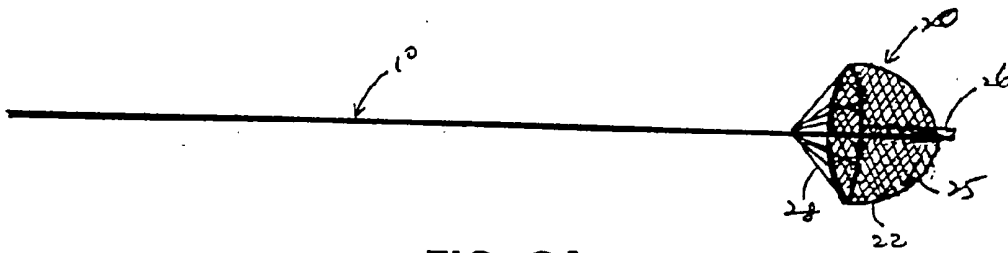

FIG. 3A

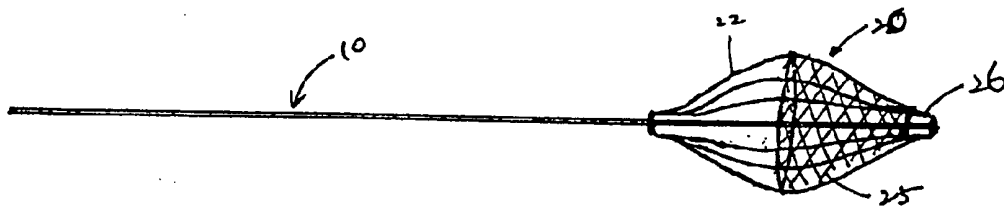

FIG. 3B

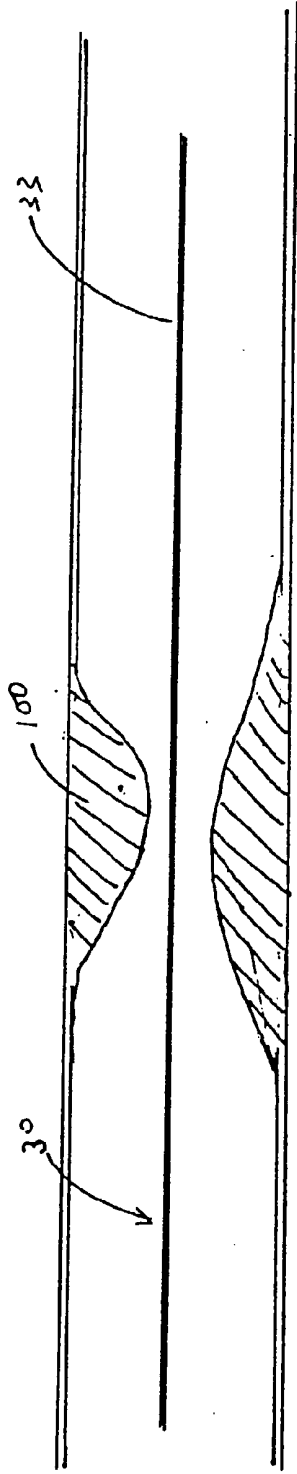

FIG. 4A

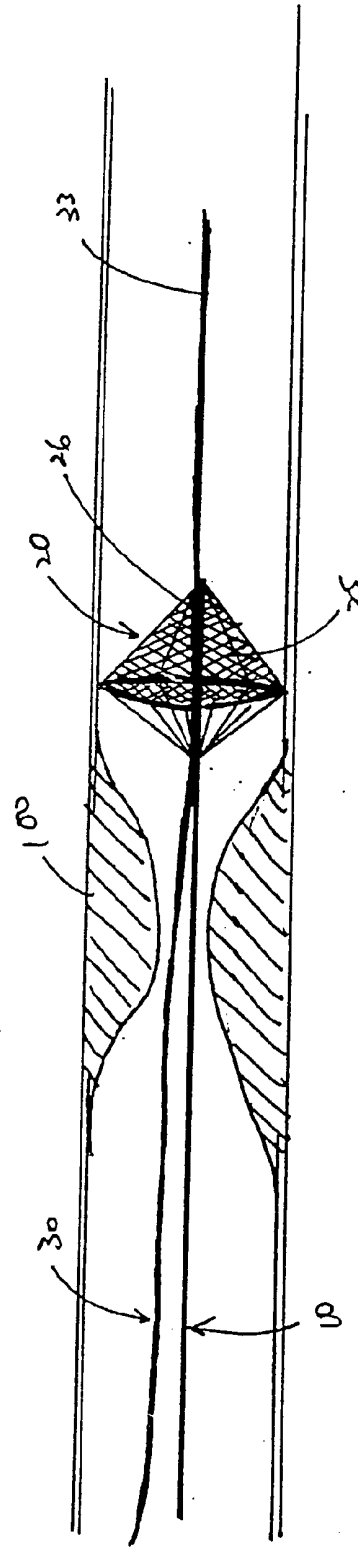

FIG. 4B

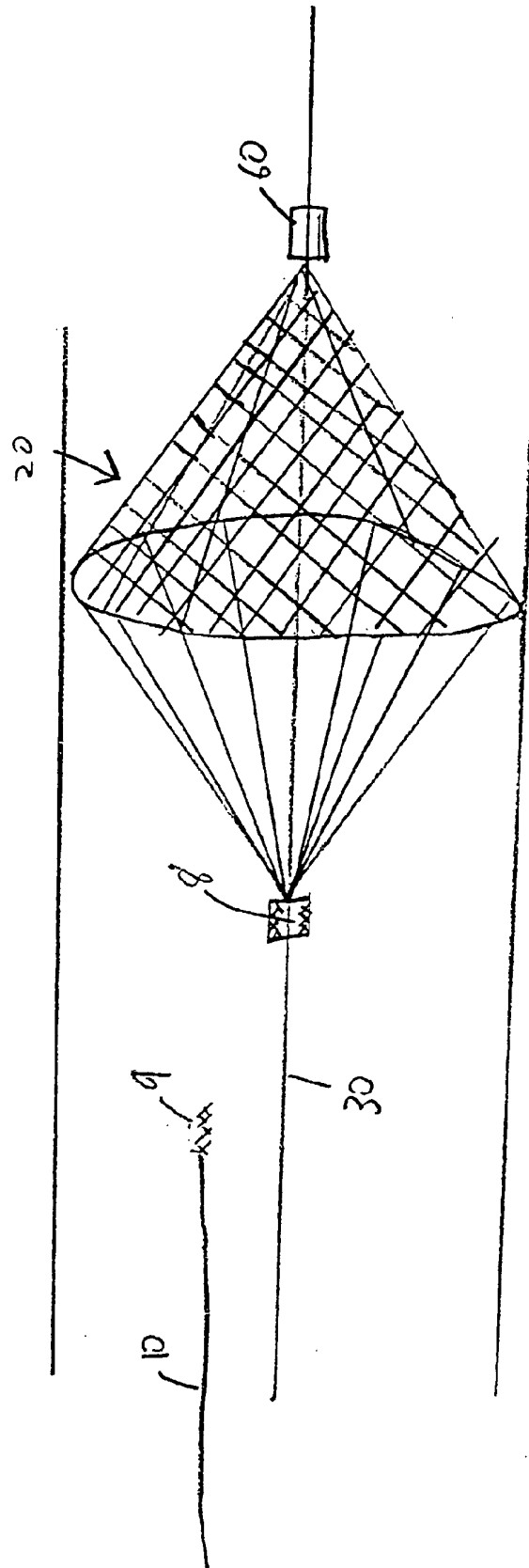

FIG. 4C

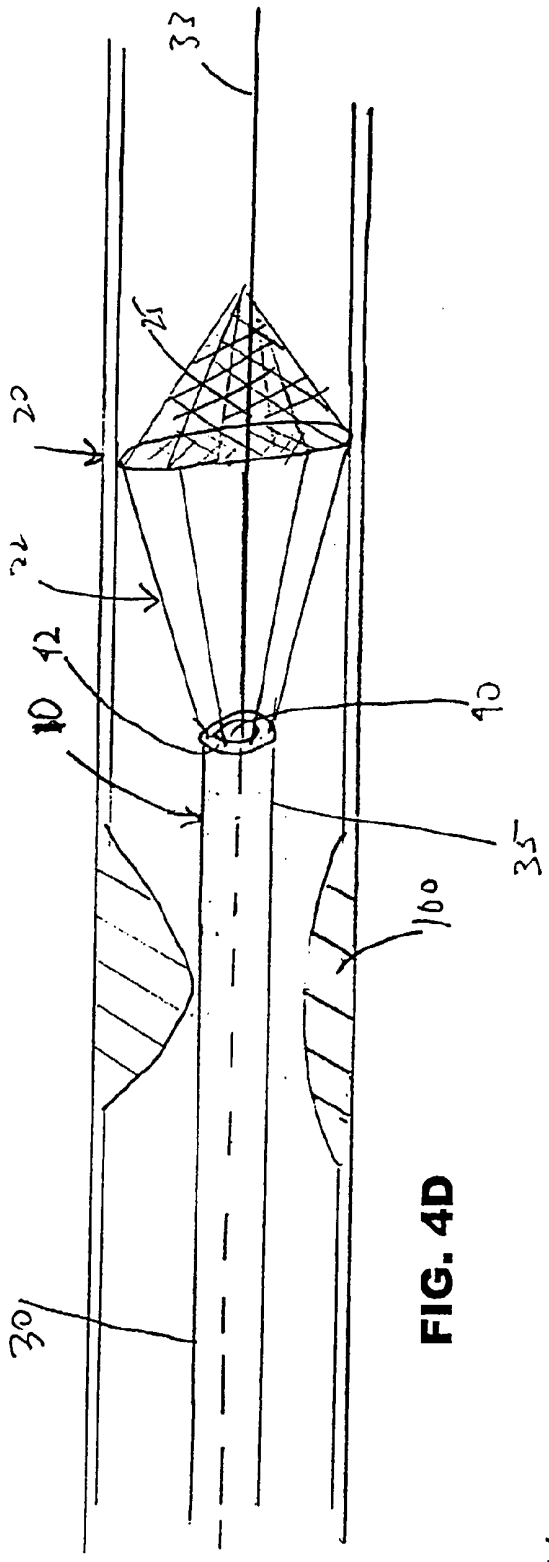

FIG. 4D

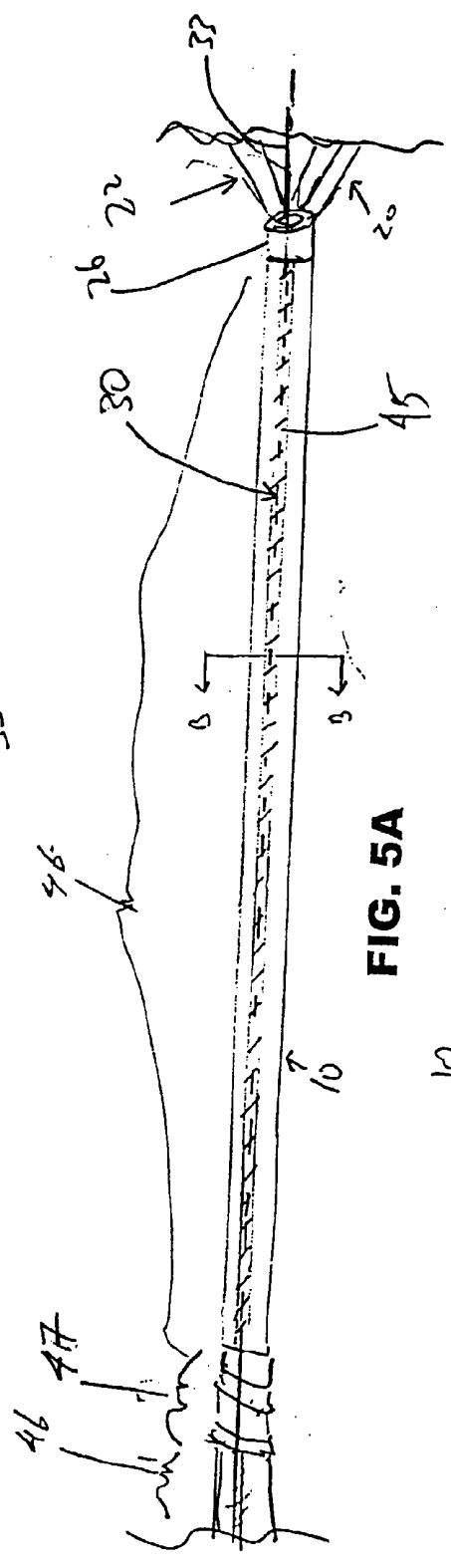

FIG. 5A

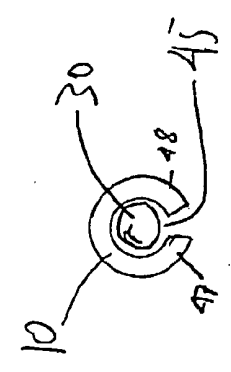

FIG. 5B

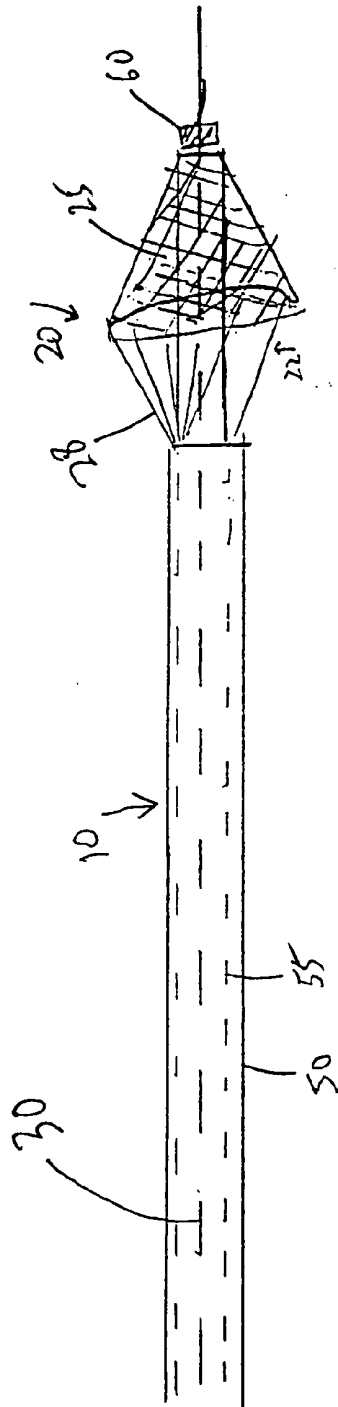

FIG. 6

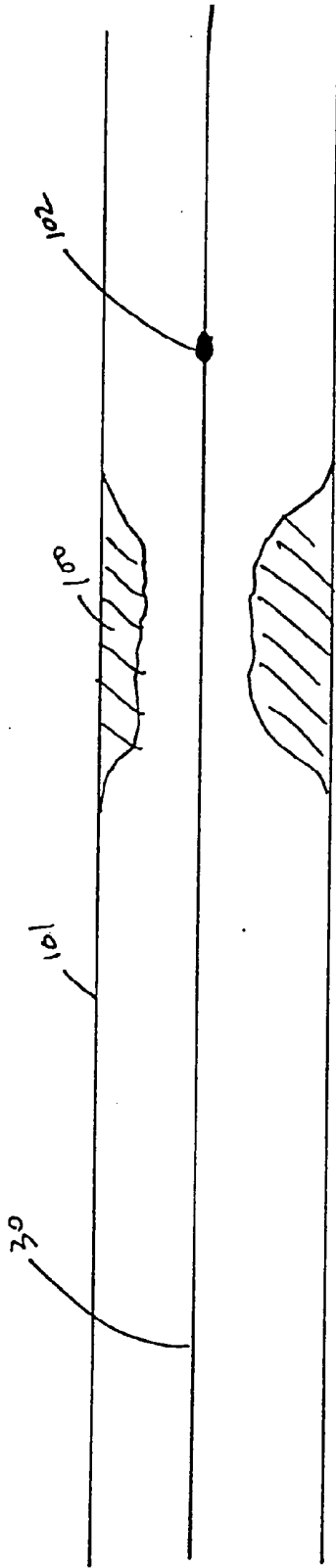

FIG. 7A

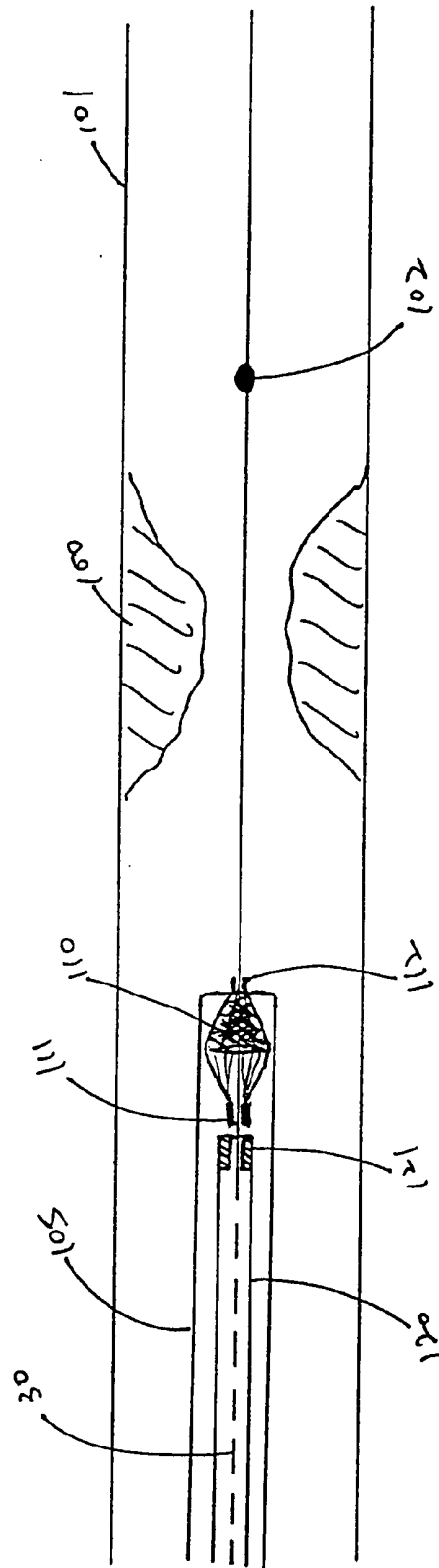

FIG. 7B

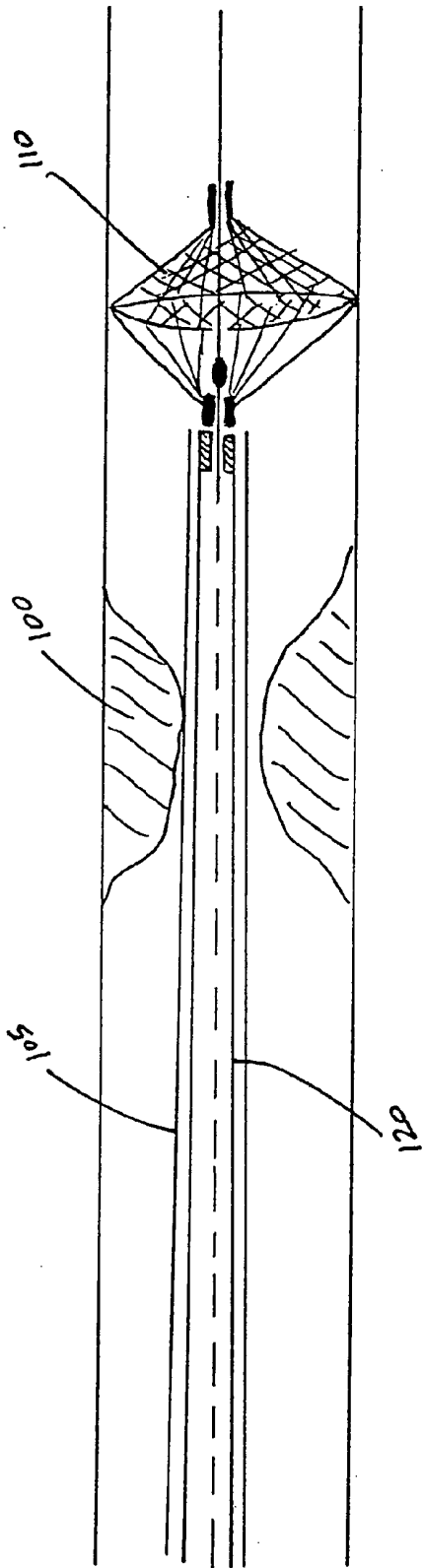

FIG. 7C

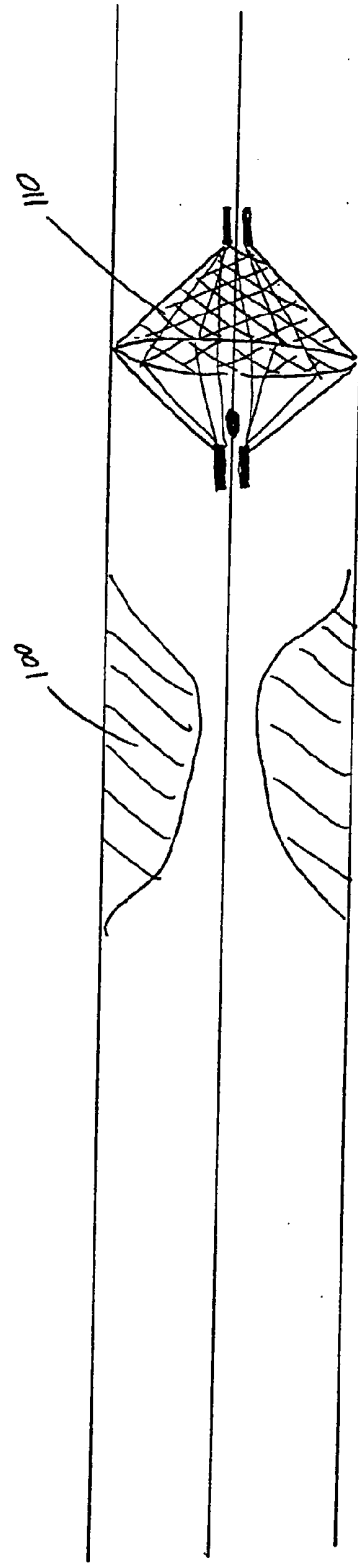

FIG. 7D

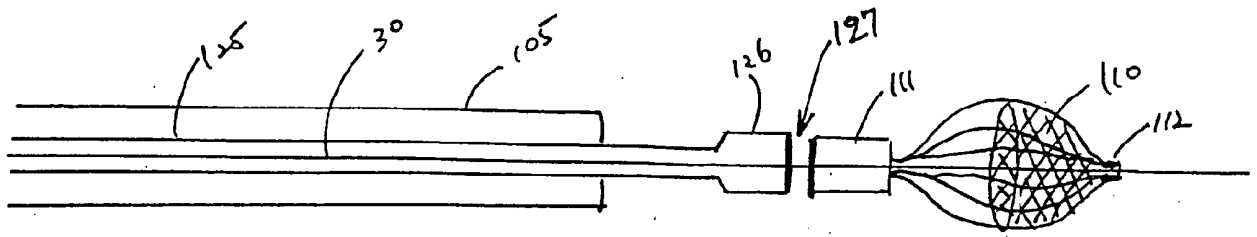

FIG. 8

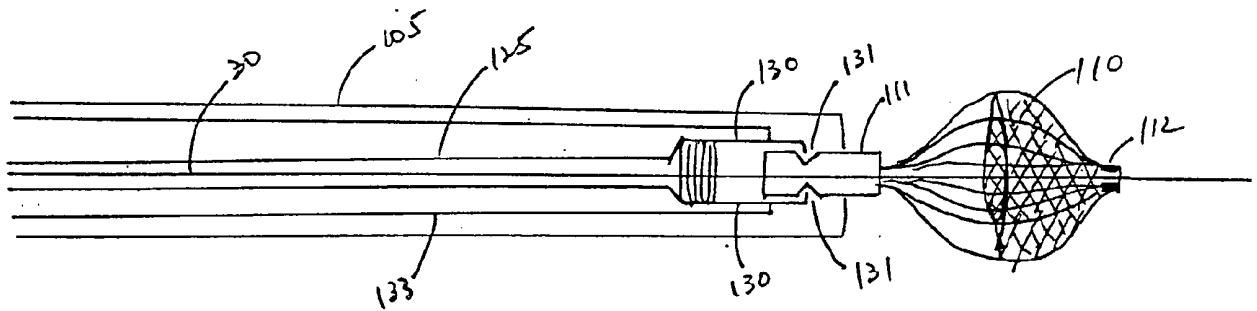

FIG. 9A

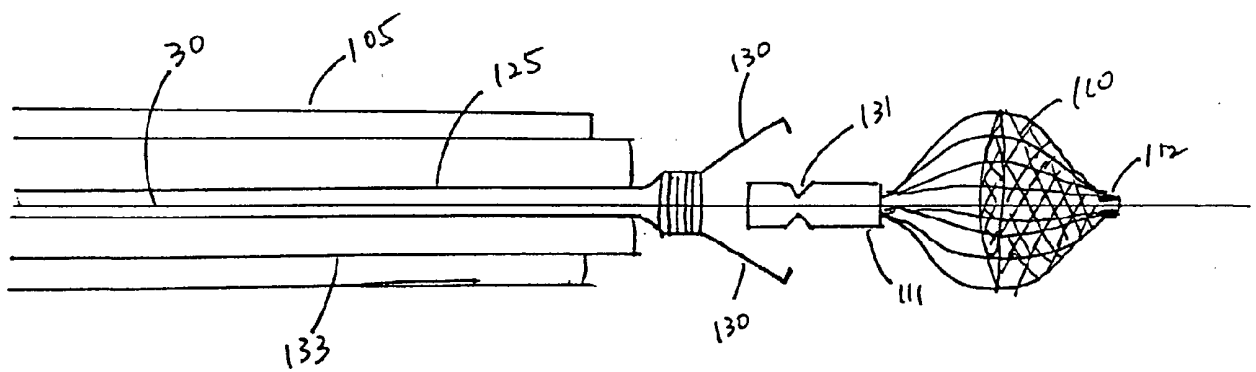

FIG. 9B

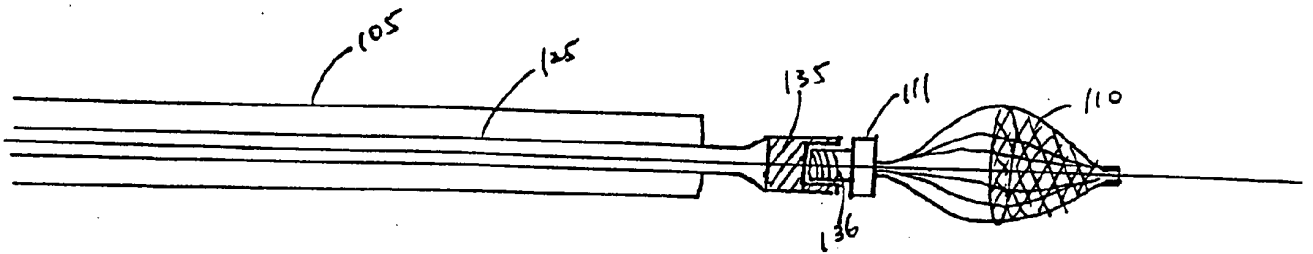

FIG. 10A

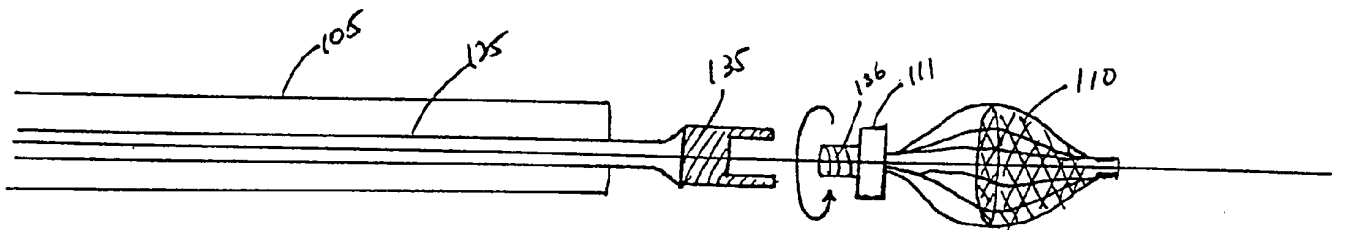

FIG. 10B

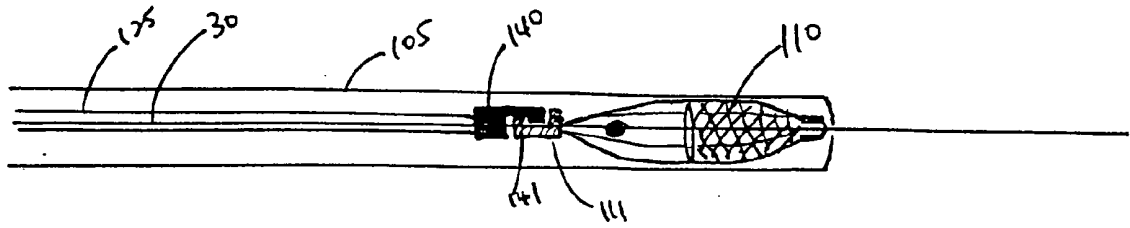

FIG. 11A

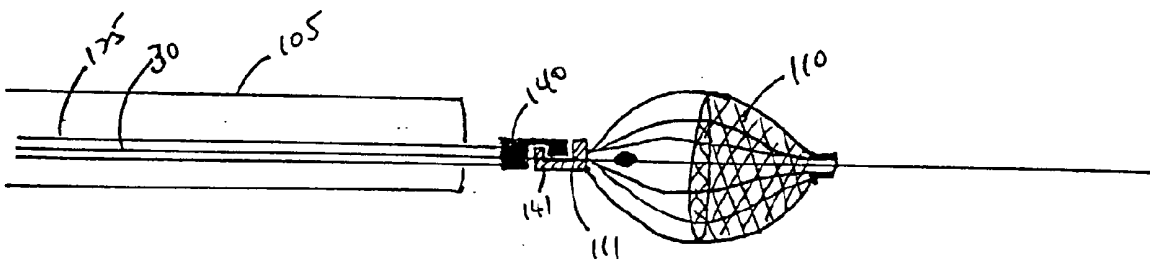

FIG. 11B

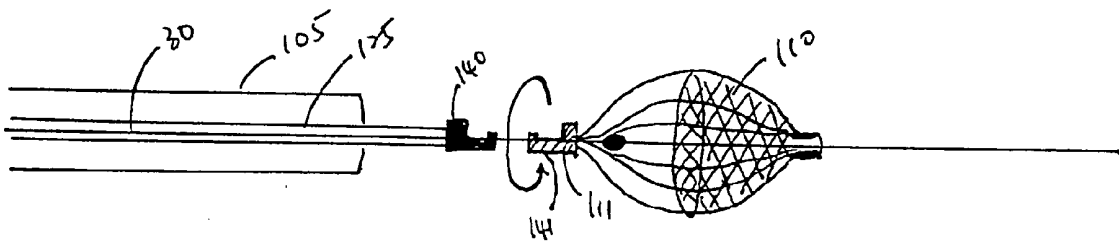

FIG. 11C

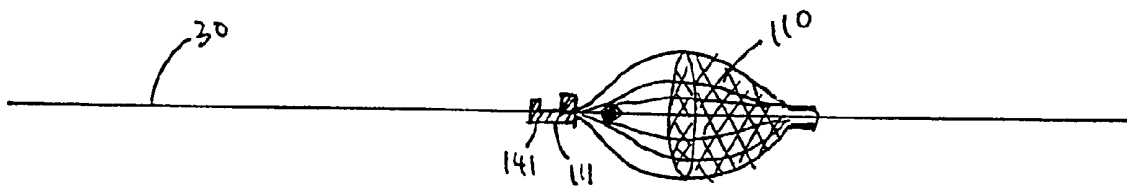

FIG. 11D

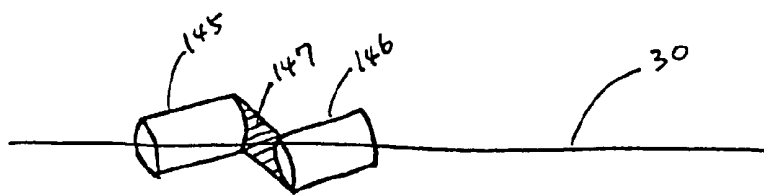

FIG. 12A

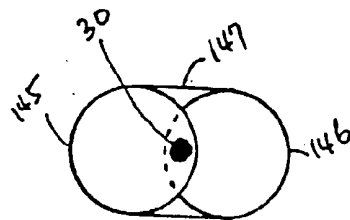

FIG. 12B

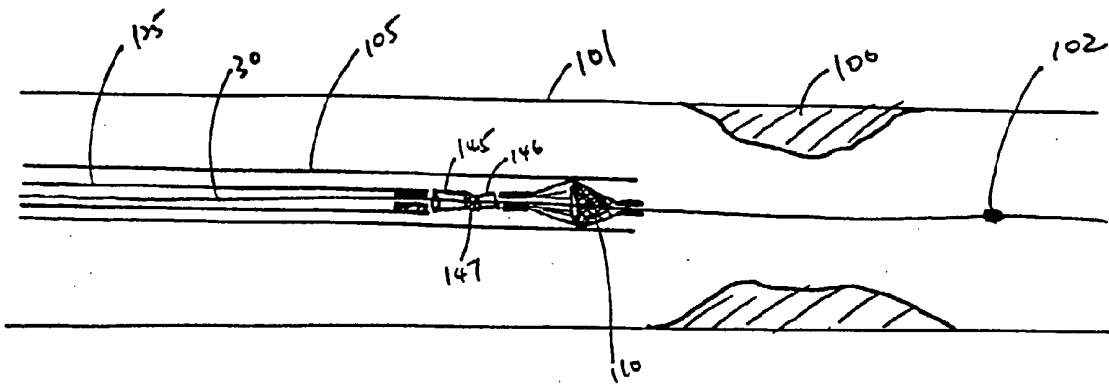

FIG. 12C

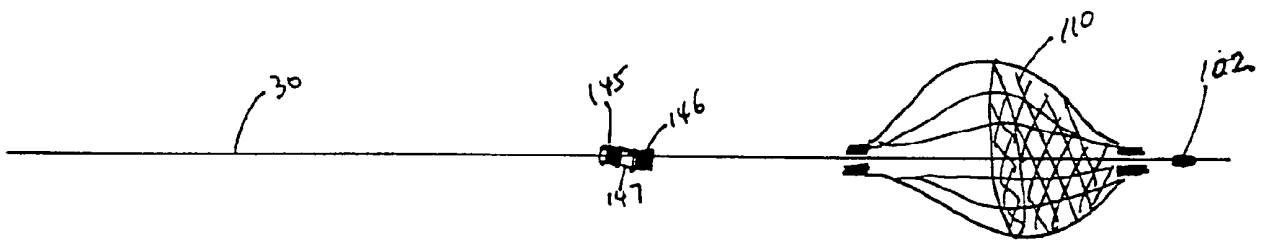

FIG. 12D

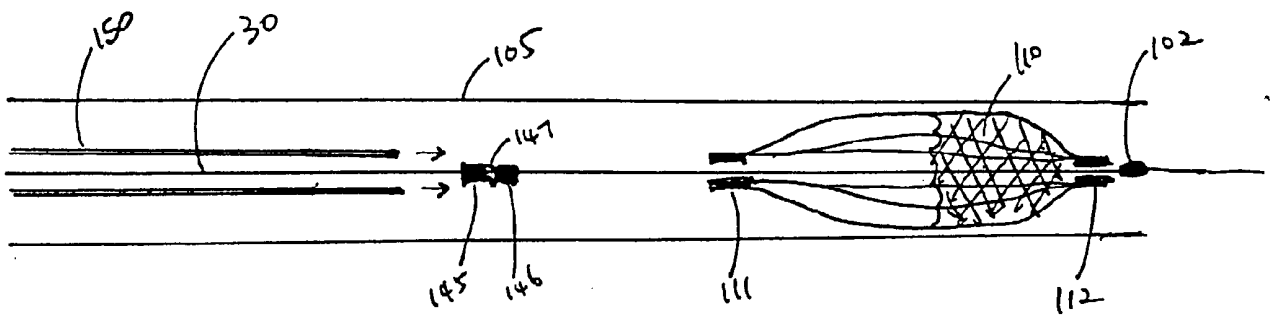

FIG. 12E

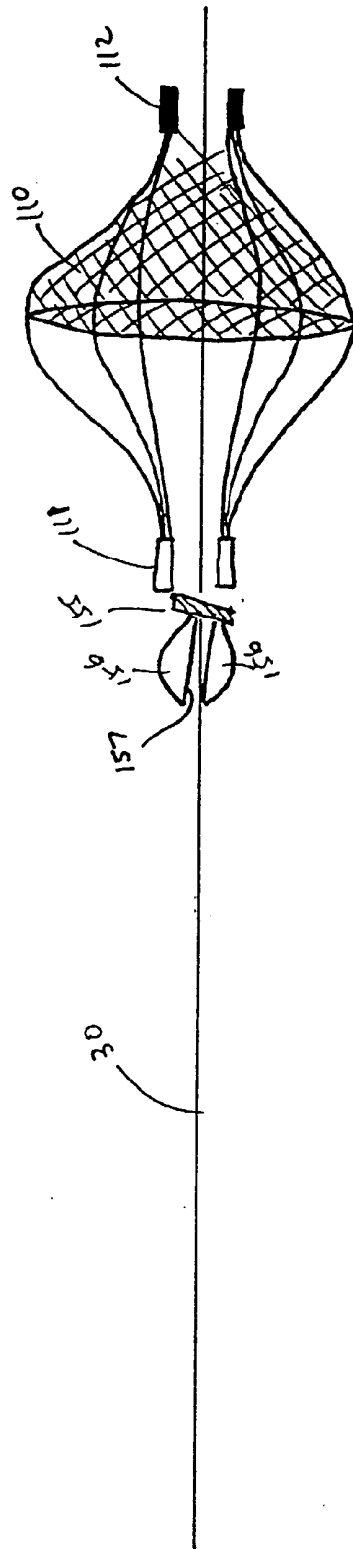

FIG. 13A

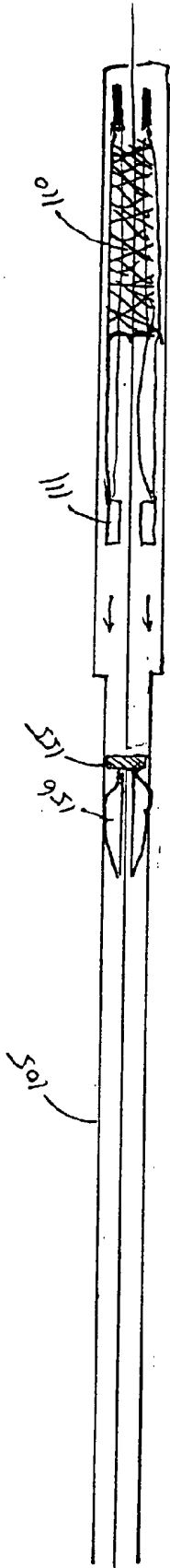

FIG. 13B

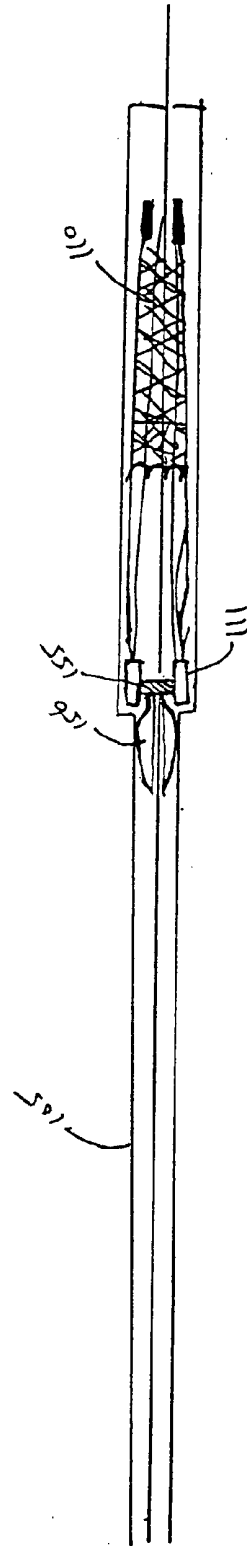

FIG. 13C

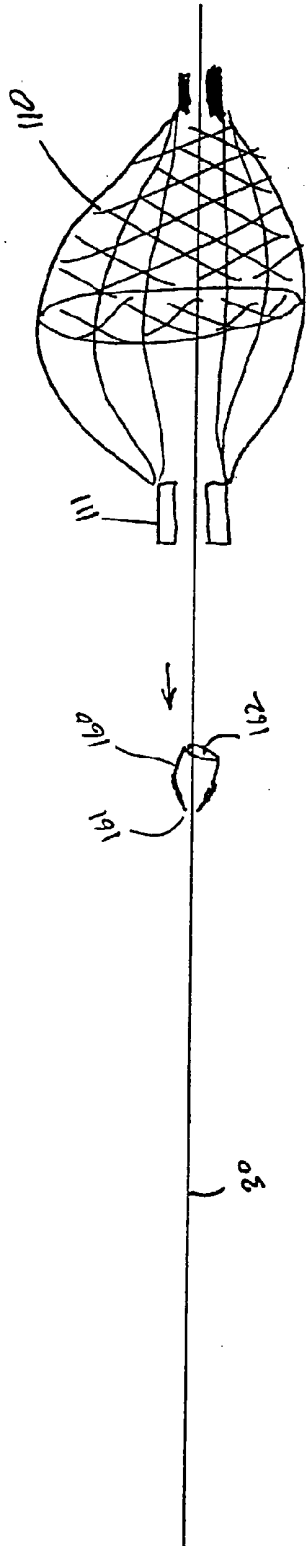

FIG. 14A

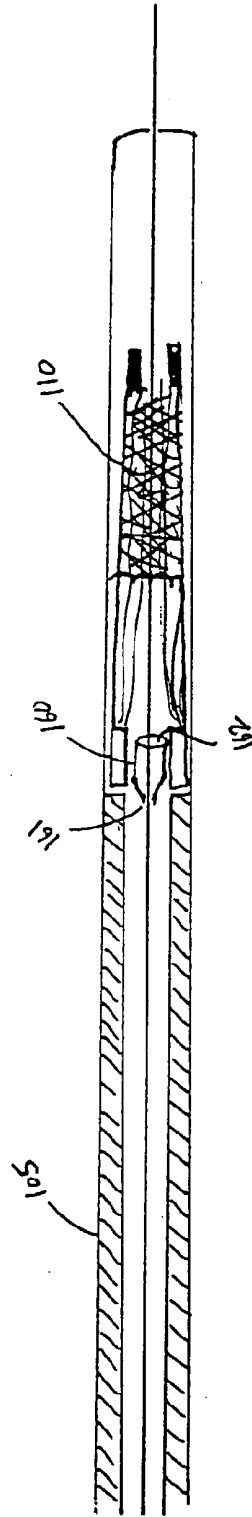

FIG. 14B



FIG. 15A

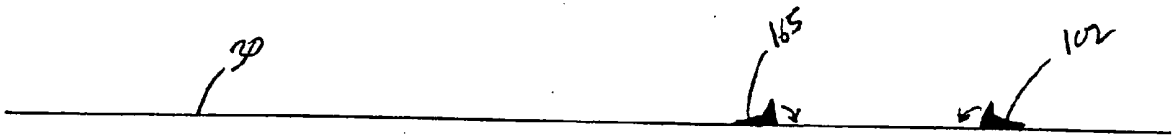

FIG. 15B

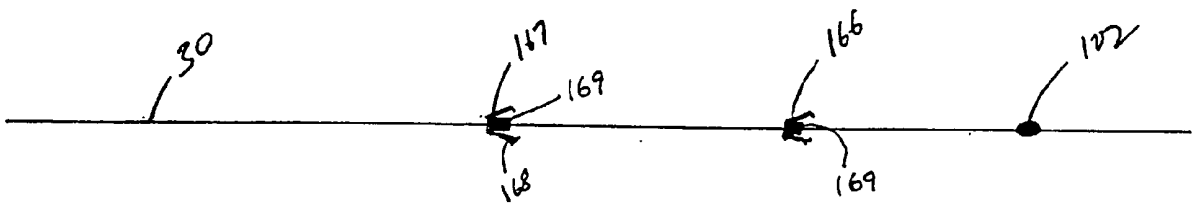

FIG. 15C

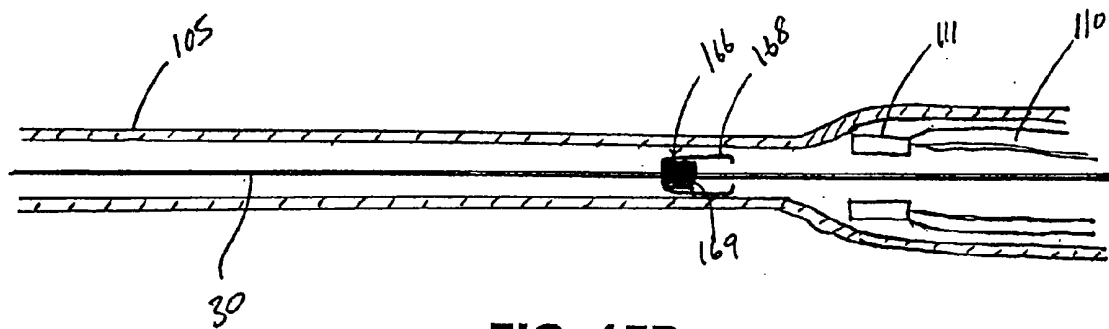

FIG. 15D

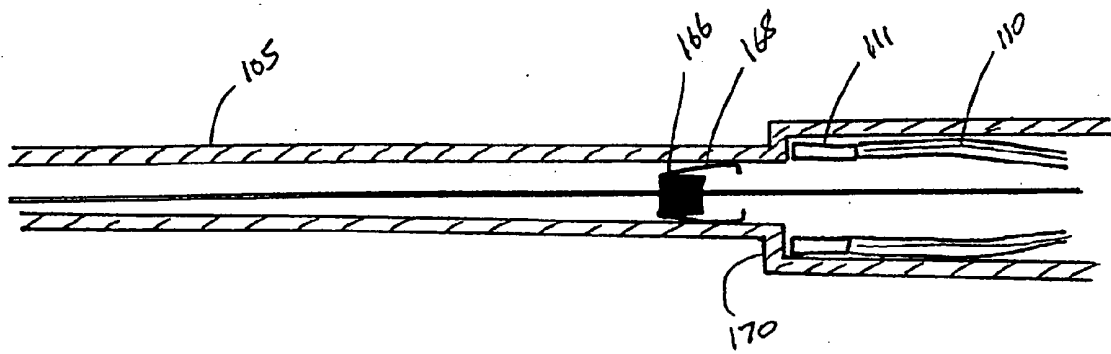

FIG. 15E

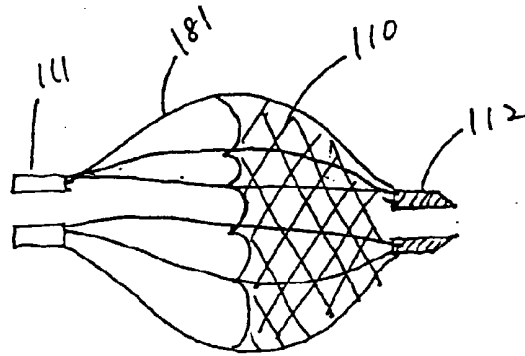

FIG. 16A

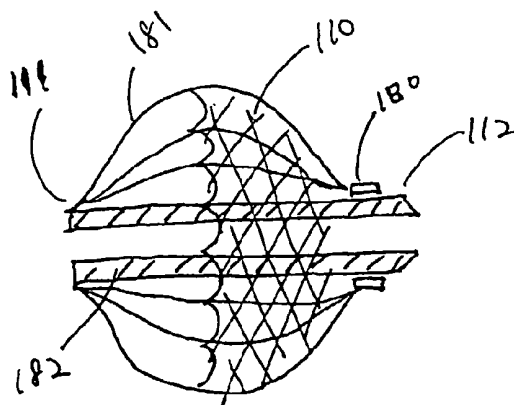

FIG. 16B

INTERNATIONAL SEARCH REPORT

International Application No
PCT/US 00/31402

A. CLASSIFICATION OF SUBJECT MATTER IPC 7 A61F2/01												
According to International Patent Classification (IPC) or to both national classification and IPC												
B. FIELDS SEARCHED Minimum documentation searched (classification system followed by classification symbols) IPC 7 A61F												
Documentation searched other than minimum documentation to the extent that such documents are included in the fields searched												
Electronic data base consulted during the international search (name of data base and, where practical, search terms used) EPO-Internal												
C. DOCUMENTS CONSIDERED TO BE RELEVANT												
Category °	Citation of document, with indication, where appropriate, of the relevant passages	Relevant to claim No.										
X A	WO 99 25252 A (BREEDVELD HENDRIK G ; BOSMA GJALT (NL); CORDIS CORP (US)) 27 May 1999 (1999-05-27) page 6, paragraph 2; figures page 9, paragraph 3 --- -/--	51-54 64-67, 95-97, 105-108, 114, 115										
<input checked="" type="checkbox"/> Further documents are listed in the continuation of box C.												
<input checked="" type="checkbox"/> Patent family members are listed in annex.												
° Special categories of cited documents:												
<table border="0"> <tr> <td>*A* document defining the general state of the art which is not considered to be of particular relevance</td> <td>*T* later document published after the international filing date or priority date and not in conflict with the application but cited to understand the principle or theory underlying the invention</td> </tr> <tr> <td>*E* earlier document but published on or after the international filing date</td> <td>*X* document of particular relevance; the claimed invention cannot be considered novel or cannot be considered to involve an inventive step when the document is taken alone</td> </tr> <tr> <td>*L* document which may throw doubts on priority claim(s) or which is cited to establish the publication date of another citation or other special reason (as specified)</td> <td>*Y* document of particular relevance; the claimed invention cannot be considered to involve an inventive step when the document is combined with one or more other such documents, such combination being obvious to a person skilled in the art.</td> </tr> <tr> <td>*O* document referring to an oral disclosure, use, exhibition or other means</td> <td>*&* document member of the same patent family</td> </tr> <tr> <td>*P* document published prior to the international filing date but later than the priority date claimed</td> <td></td> </tr> </table>			*A* document defining the general state of the art which is not considered to be of particular relevance	*T* later document published after the international filing date or priority date and not in conflict with the application but cited to understand the principle or theory underlying the invention	*E* earlier document but published on or after the international filing date	*X* document of particular relevance; the claimed invention cannot be considered novel or cannot be considered to involve an inventive step when the document is taken alone	*L* document which may throw doubts on priority claim(s) or which is cited to establish the publication date of another citation or other special reason (as specified)	*Y* document of particular relevance; the claimed invention cannot be considered to involve an inventive step when the document is combined with one or more other such documents, such combination being obvious to a person skilled in the art.	*O* document referring to an oral disclosure, use, exhibition or other means	*&* document member of the same patent family	*P* document published prior to the international filing date but later than the priority date claimed	
A document defining the general state of the art which is not considered to be of particular relevance	*T* later document published after the international filing date or priority date and not in conflict with the application but cited to understand the principle or theory underlying the invention											
E earlier document but published on or after the international filing date	*X* document of particular relevance; the claimed invention cannot be considered novel or cannot be considered to involve an inventive step when the document is taken alone											
L document which may throw doubts on priority claim(s) or which is cited to establish the publication date of another citation or other special reason (as specified)	*Y* document of particular relevance; the claimed invention cannot be considered to involve an inventive step when the document is combined with one or more other such documents, such combination being obvious to a person skilled in the art.											
O document referring to an oral disclosure, use, exhibition or other means	*&* document member of the same patent family											
P document published prior to the international filing date but later than the priority date claimed												
Date of the actual completion of the international search 21 March 2001		Date of mailing of the international search report 28/03/2001										
Name and mailing address of the ISA European Patent Office, P.B. 5818 Patentlaan 2 NL - 2280 HV Rijswijk Tel. (+31-70) 340-2040, Tx. 31 651 epo nl, Fax: (+31-70) 340-3016		Authorized officer Neumann, E										

INTERNATIONAL SEARCH REPORT

 Int'l Application No
 PCT/US 00/31402

C.(Continuation) DOCUMENTS CONSIDERED TO BE RELEVANT		
Category °	Citation of document, with indication, where appropriate, of the relevant passages	Relevant to claim No.
X	WO 99 23976 A (TAYLOR CHARLES ;BRADY EAMON (IE); GILSON PAUL (IE); MAHER PADRAIG) 20 May 1999 (1999-05-20) cited in the application page 2, line 25 -page 12, line 27; figures	51-56
A		64-69, 90,92, 95-98, 105-110, 114,115
P,X	--- US 6 142 987 A (TSUGITA ROSS S) 7 November 2000 (2000-11-07) column 4, line 9 - line 38; figures	51-53
A		64-66, 92,105, 106,110, 114,115

INTERNATIONAL SEARCH REPORT

Information on patent family members

Int. Patent Application No

PCT/US 00/31402

Patent document cited in search report	Publication date	Patent family member(s)	Publication date
WO 9925252 A	27-05-1999	NL 1007584 C EP 1032311 A	20-05-1999 06-09-2000
WO 9923976 A	20-05-1999	AU 9758398 A BR 9813935 A DE 19882777 T DE 29880158 U EP 1028670 A GB 2345253 A IE 81060 B NO 20002303 A PL 340258 A	31-05-1999 19-09-2000 26-10-2000 30-11-2000 23-08-2000 05-07-2000 12-01-2000 04-05-2000 29-01-2001
US 6142987 A	07-11-2000	WO 0108596 A	08-02-2001