

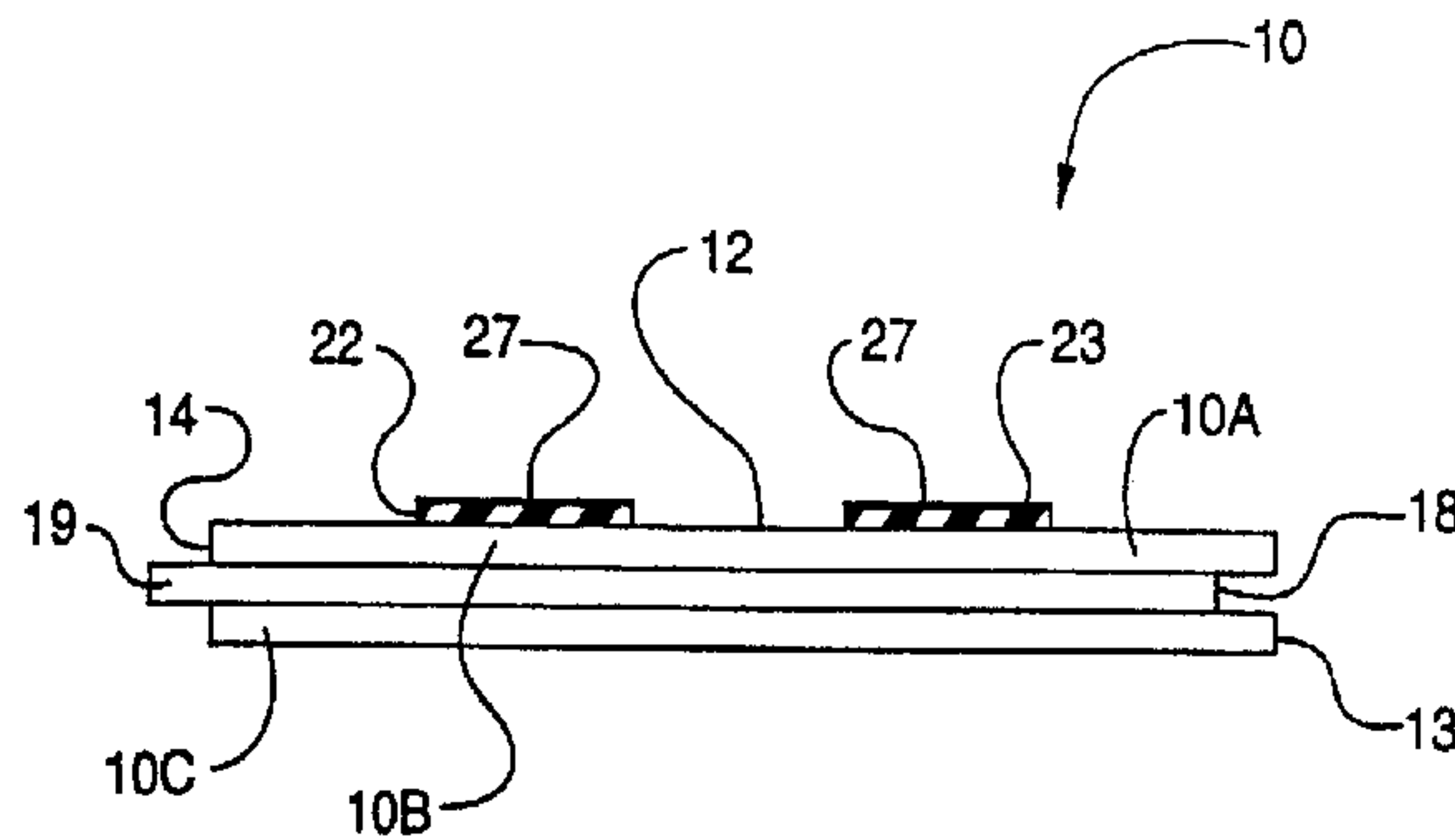

(22) Date de dépôt/Filing Date: 1998/08/04
 (41) Mise à la disp. pub./Open to Public Insp.: 1999/02/04
 (45) Date de délivrance/Issue Date: 2003/06/03
 (30) Priorité/Priority: 1997/08/04 (08/905,551) US

(51) Cl.Int.⁶/Int.Cl.⁶ E04F 15/04, B32B 3/22, B32B 7/14,
B32B 21/00, E04B 5/12
 (72) Inventeur/Inventor:
SWEET, JAMES C., US
 (73) Propriétaire/Owner:
TRIANGLE PACIFIC CORPORATION, US
 (74) Agent: MBM & CO.

(54) Titre : REVETEMENT DE SOL EN BOIS PREFINI A ENCOLLER
 (54) Title: GLUE-DOWN PREFINISHED WOOD FLOORING PRODUCT



(57) **Abrégé/Abstract:**

A flooring product for application to a subfloor which includes a wooden flooring component for installation with like flooring components to form a floor. The flooring component has a top surface for being exposed after installation and a base surface, a pressure-sensitive adhesive carried on a foam tape applied and permanently adhered directly to the base surface of the flooring component for providing an attachment interface surface for adhering the flooring component to the subfloor, and a protective release cover applied and releasably adhered to the attachment interface surface of the adhesive to protect the adhesive until removal of the release cover when the flooring component is applied to the subfloor.

Abstract of the Disclosure

A flooring product for application to a subfloor which includes a wooden flooring component for installation with like flooring components to form a floor. The flooring component has a top surface for being exposed after installation and a base surface, a pressure-sensitive adhesive carried on a foam tape applied and permanently adhered directly to the base surface of the flooring component for providing an attachment interface surface for adhering the flooring component to the subfloor, and a protective release cover applied and releasably adhered to the attachment interface surface of the adhesive to protect the adhesive until removal of the release cover when the flooring component is applied to the subfloor.

GLUE-DOWN PREFINISHED WOOD FLOORING PRODUCT

Technical Field and Background of the Invention

This invention relates to a glue-down prefinished wood flooring product. Wooden flooring is typically installed by either nailing strips of adjacent wood flooring strips to a subfloor to form an essentially seamless wooden flooring surface, or by applying wood flooring strips to a subfloor which has been pre-coated with, for example, a mastic-type layer into which the flooring strips are embedded.

There are significant differences in the problems associated with parquet flooring blocks versus elongate hardwood flooring strips. Since parquet blocks are normally square, they are substantially more stable and less prone to warping and pulling away from the subflooring. Hartco presently manufactures a parquet product which is serviceable.

There is a need in the market for a prefinished hardwood strip flooring product which can be adhered by an adhesive directly to a suitable subfloor, and which will serve with the same durability and longevity as other, more expensive wood flooring systems. This flooring product should preferably have the same solid "feel" as a full thickness, solid hardwood floor of the type typically nailed into place, without any of the "spring" or "bounce" which characterizes prior art glue-down flooring systems which rely on relatively thick foam adhesive pads to adhere the system to the subfloor.

The product according to the application is faster, easier and less expensive to install than either an unfinished nail-down flooring system or a flooring system laid into a pre-applied mastic layer. The product has particular application in the flooring aftermarket for use by "do-it-yourself" homeowners who want the expensive look of high quality hardwood flooring without

the disruption resulting from a contractor-installed floor. There is presently a trend back towards the use of hardwood flooring, and many homeowners are removing existing carpeting in order to replace it with hardwood flooring. A flooring system which can be installed onto a subfloor onto which a carpet was previously installed without the need to raise doors and moldings to accommodate a greater thickness is desirable, since it simplifies the do-it-yourself installation process.

The flooring product according to this application address those needs. In particular, the combination of substantially increased flexibility of the flooring strip and a much thinner foam tape and aggressive adhesive provides a high-quality, long-lasting and durable product without the disadvantages observed in prior products.

Summary of the Invention

Therefore, it is an object of the invention to provide a glue-down wood flooring system which can be installed easily by do-it-yourself installers.

It is another object of the invention to provide a glue-down wood flooring system which is as durable as conventional wood flooring systems, such as nail-down flooring systems.

It is another object of the invention to provide a glue-down wood flooring system which utilizes an adhesive which does not add significantly to the thickness of the flooring product.

It is another object of the invention to provide a glue-down wood flooring system which, after installation, is indistinguishable in appearance and serviceability from conventional wood flooring systems, such as nail-down flooring systems.

It is another object of the invention to provide a glue-down wood flooring system which

is sufficiently low profile so that it can be installed on subfloors where carpet was previously installed without raising the doors and moldings.

It is another object of the invention to provide a glue-down wood flooring system which can be installed over a wide variety of subfloors without extensive preparation.

5 It is another object of the invention to provide a glue-down wood flooring system which is aggressively bonded to the subfloor.

These and other objects of the present invention are achieved in the preferred
embodiments disclosed below by providing a wooden flooring strip, comprising a top surface
having a decorative finish and a base surface opposed to said top surface. The base surface has
10 a multiplicity of closely spaced-apart spaces extending into the flooring strip from the base
surface transverse to the length of the flooring strip along substantially the entire length of the
flooring strip to relieve stress and increase flexibility in the wood strip for more closely adhering
to irregularities of a sub-floor. Locking means extend along the length of said flooring strip on
first and second opposed side edges for locking adjacent flooring strips together side-to-side to
15 form an assembled wood floor. The locking means comprise a tongue formed on said first side
edge of the flooring strip and a groove formed in the second side edge of the flooring strip. The
tongue and grooves provide mating connection with complementary elements on adjacent
flooring strips. The flooring strips have opposing end portions, said end portions each having
a single flat area encompassing the entire end portion surface area perpendicular to the plane of
20 the flooring strip for abutting engagement with like flat areas on adjacent flooring strips. At least
one strip of pressure sensitive adhesive-coated foam tape is applied to the base surface for
adhering said flooring strip to the subfloor. A protective cover covers said adhesive until

removal just prior to installation to the subfloor.

Preferably, the foam tape includes adhesive on said tape for adhering the tape to the base surface of the flooring strip.

5 According to one preferred embodiment of the invention, the foam tape comprises an closed cell polyethylene foam.

According to another preferred embodiment of the invention, the adhesive comprises an acrylate pressure sensitive adhesive.

10 According to yet another preferred embodiment of the invention, the flooring component is selected from the group consisting of solid wood strip, laminated wood strip, solid parquet block or laminated parquet block.

15 According to yet another preferred embodiment of the invention, the adhesive layer is positioned on the base surface of the flooring strip in spaced-apart relation to both side edges for providing an attachment interface surface for adhering the flooring component to the subfloor while permitting interconnection of the flooring strip with an adjacent, like flooring strip without contact of the adhesive with the subfloor.

According to yet another preferred embodiment of the invention, the flooring strip includes a top layer, an intermediate layer and a base layer laminated together in registration with each other.

20 According to yet another preferred embodiment of the invention, the spaces in the flooring strip are formed by scoring the base layer of the flooring strip.

According to yet another preferred embodiment of the invention, the spaces in the flooring strip are formed by adhering a plurality of spaced-apart wood pieces in an array to the

intermediate layer.

According to yet another preferred embodiment of the invention, the flooring strip includes two spaced-apart and parallel lengths of foam tape extending along the length of the flooring strip.

5 According to one preferred embodiment of the invention, a wooden flooring strip is provided comprising a top surface having a decorative finish and a base surface opposed to said top surface. The base surface has a multiplicity of closely spaced-apart spaces extending into the flooring strip from the base surface transverse to the length of the flooring strip along substantially the entire length of the flooring strip to relieve stress and increase flexibility in the
10 wood strip for more closely adhering to irregularities of a sub-floor. Locking means extend along the length of said flooring strip on first and second opposed side edges for locking adjacent flooring strips together side-to-side to form an assembled wood floor. The locking means comprise a tongue formed on said first side edge of the flooring strip and a groove formed in the second side edge of the flooring strip. The tongue and grooves provide mating connection
15 with complementary elements on adjacent flooring strips. The flooring strips have opposing end portions, said end portions each having a single flat area encompassing the entire end portion surface area perpendicular to the plane of the flooring strip for abutting engagement with like flat areas on adjacent flooring strips. At least one strip of pressure sensitive adhesive-coated foam tape is applied to the base surface for adhering said flooring strip to the subfloor. A
20 protective cover covers said adhesive until removal just prior to installation to the subfloor. The foam tape has a thickness no greater than 1/32 inch, or about 8% of the total thickness of the flooring strip.

Brief Description of the Drawings

Some of the objects of the invention have been set forth above. Other objects and advantages of the invention will appear as the invention proceeds when taken in conjunction with the following drawings, in which:

5 Figure 1 is a perspective view of the finished side of a flooring strip according to a preferred embodiment of the present invention;

 Figure 2 is a perspective view of the unfinished side of the flooring strip shown in Figure 1;

10 Figure 3 is an enlarged, vertical cross-sectional view laterally through the flooring strip shown in Figures 1 and 2;

 Figure 4 is a fragmentary side elevation of the flooring strip;

 Figure 5 is a fragmentary, enlarged, vertical cross-sectional view longitudinally through the flooring strip shown in Figures 1 and 2; and

15 Figure 6 is a perspective view of a floor created from assembled flooring strips according to an embodiment of the invention.

Description of the Preferred Embodiment and Best Mode

General Description

20 Referring now specifically to the drawings, a wooden flooring strip according to the present invention is illustrated in Figure 1 and shown generally at reference numeral 10. Flooring strip 10 may be any suitable length, width and thickness, but typical sizes and constructions are 1/4th, 3/8ths, 1/2 and 15/16ths-inch thick laminated or solid oak flooring strips

between 2 and 1/4th and 8 inches wide and up to 5 feet long, or as parquet blocks. A three-layer laminated construction is shown in the Figures. See particularly Figure 3.

5 Flooring strip 10 has a top surface 11, which may be finished or unfinished, an opposite base surface 12, opposed side edges 13 and 14 and end edges 15 and 16. The flooring strip 10 includes a groove 18 which extends along side edge 13 and a mating tongue 19 which extends along the opposite side edge 14. Grooves 18 and tongues 19 of adjacent flooring strips mate to form a substantially seamless floor.

10 As is shown in Figures 2 and 3, the base surface 12 is provided with transverse scores 20. The scores 20 extend from side to side in closely spaced-apart relation transverse to the length of the flooring strip 10 along substantially the entire length of the of the flooring strip 10, substantially as disclosed in applicant's United States Patent No. 5,283,102. In accordance with a preferred embodiment of the invention, the scores 20 are 1/8th inch wide, 1/8th inch deep, and are spaced-apart one inch on center. Other widths, depths and spacings are also possible.

15 As is shown in Figure 2, the flooring strip 10 according to one preferred embodiment of the invention is a laminate structure having three wood layers, 10A, 10B, 10C bonded together under heat and pressure. According to one embodiment of the invention, the top layer 10A is a thin veneer layer of solid, unblemished, high quality wood, such as oak, while the middle and base layers 10B and 10C are either blemished strips of the same type of wood, or a less expensive type of wood. In embodiments wherein blemished wood is used on the base
20 layer 10C, the pressure-sensitive adhesive system described below provides a cosmetic covering over all of some and portion of other blemishes until application of the flooring strip 10 to the subfloor. This provides an enhanced appearance to the product and more accurately reflects the

actual quality of the entire product.

Two strips 22 and 23 of a pressure sensitive foam adhesive system are adhered to the base surface 12 of flooring strip 10, as is shown in Figure 2. The adhesive strips 22 and 23 are applied in lengthwise-extending lengths from one end of the flooring strip 10 to the other. See generally also Figure 4.

As is best shown in Figure 5, each of the adhesive system strips 22 and 23 (exemplified by strip 22) is a laminated assembly including a first acrylate adhesive layer 24 by which the assembly is bonded to the flooring strip 10. One side of a polyethylene foam tape layer 25 provides a substrate to support and carry the adhesive layer 24, and simultaneously provides a suitable degree of cushioning to the flooring strips 10 upon installation to form a floor. The other side of the foam tape layer 25 supports a second acrylate adhesive layer 26 which remains covered by a release paper 27 and protects the adhesive layer 26 until the flooring strip 10 is ready to be applied to the subfloor, as which time it is removed as described below.

The preferred pressure sensitive system as generally described above is a double-coated polyethylene foam tape, Product Description No. 4492 manufactured by Minnesota Mining and Manufacturing Company. The adhesive applied to the polyethylene foam is an acrylate adhesive possessing an aggressive adherence capacity.

The preferred thickness of the adhesive system is 1/32 inch. According to one preferred method, the adhesive strips 22 and 23 are supplied by the manufacturer in a long, continuous strip on a roll, which includes a release paper or film (not shown) which protects the adhesive which will bond with the base surface 12 until application of the strips 22 and 23 to the base surface 12 of the flooring strip 10. The base surface 12 is sanded with a belt sander carrying 150

grit sandpaper, and then heated to approximately 125-135° F. The heating softens the adhesive as it contacts the wood and creates a more intimate bond.

Alternatively, rubber-based adhesives may be used, and may be preferable under some conditions and circumstances.

5 The release paper is removed and the adhesive layer exposed as the strips of tape are pressed onto the base surface of the flooring strip 10.

10 The strips are preferably spaced from both side edges 13 and 14 of the flooring strip 10, leaving bare wood on both side edges and the adjacent portions of the base surface 12 of the flooring strip 10. Preferably, each of the tape strips 22 and 23 are 3/4 inches wide and are symmetrically offset relative to the centerline of the flooring strip 10. This provides a centered length of bare wood extending along the length of the flooring strip 10 between tape strips 22 and 23, and two lengths of bare wood, each 1/8 inch wide, extending along the opposing side edges 13 and 14.

15 Other configurations are possible, and are optimized depending on the thickness, width and flexibility of the flooring strips, and the anticipated subfloor characteristics. In some applications a single, wider adhesive tape strip or three or more parallel strips may be more suitable.

20 The opposing ends 15 and 16 of the wood flooring strip 10 are formed without tongue and groove locking means, but are cut to provide a abutting connection between the end 15 and the end 16 of adjacent laminated wood flooring strips 10. The abutting ends 15 and 16 of the laminated wood flooring strip 10 permit an absolutely flush joint which will not pull open. A chamfer 30 is formed at both ends 15 and 16 in the base layer 10C of the wood flooring strip

20. The chamfers 30 each form an undercut area adjacent the lower edge of the ends 15 and 16. The chamfers 30 allow the wood flooring strip 10 to flex freely in conformity with the surface of the subfloor, without effecting or otherwise interfering with the placement of adjacent laminated wood flooring strips 10. For this reason, adjacent, end-to-end laminated wood flooring strips 10 can be made to lie perfectly flush edge-to-edge, without using tongue and groove or other locking means. The ability to eliminate the tongue and groove locking means on the ends 15 and 16 of the flooring strip 10 simplifies installation, since each strip 10 can be placed onto the subfloor in exact endwise alignment with the end 15 of one flooring strip 10 flush against the end 16 of an adjacent flooring strip 10. Thus, the flooring strip 10 need only be shifted sideways to lock the tongue 19 of one flooring strip 10 into the groove 18 of the laterally adjacent flooring strip 10.

The provision of abutting end engagement between end-to-end adjacent laminated wood flooring strips 20 provides a much smoother and more consistent floor surface, because the side edge tongue and groove connections 19 and 18 hold the ends 15 and 16, as well as the sides, level. Furthermore, the flooring strip 10 as described in the above embodiment can be cut to length and pieced anywhere on the floor, since a tongue and groove or other positive locking means is no longer necessary to lock the ends 15 and 16 together with adjacent laminated wood flooring strips 10. Note particularly that the end edges 15 and 16 above the chamfer 30 are flat and perpendicular to the plane of the top and base surfaces 11 and 12, so that no gap remains when end-to-end flooring strips 10 are mated.

As is shown in Figure 6, installation of the flooring strip 10 as described more specifically below creates a finished hardwood floor indistinguishable from other floors which

are more expensive and difficult to install.

The strength of the adhesive and the bond between the adhesive, the wood and the subfloor has been tested by preparing a test sample by applying a flooring strip to a section of conventional subflooring material to create a test assembly. A ten-pound weight was attached to the flooring strip to apply a vertical pull. The test assembly has withstood several months of such pull without delamination of either the flooring strip 10 from adhesive or the subfloor.

Flooring strip 10 may be applied to a number of different subfloor constructions, such as plywood, oriented strand board or 40 pound particle board. The floor can also be installed over existing floors. If the existing floor is a wood floor, all wax must be removed, since the adhesive is designed not to stick to waxed surfaces--hence the use of a wax-coated release paper. Polyurethane-finished floors need not be stripped as long as the finish is well bonded. Vinyl-type flooring can be used so long as the wear layer is intact and has a PVC or Polyurethane wear layer. The floor can be installed over a concrete subfloor if clean and dust-free. This condition can be achieved by carefully sweeping and vacuuming the floor, since dust is the most significant problem.

Plaster dust and similar materials prevent the adhesive from adhering to the subfloor, so cleaning to remove these and similar materials is very important.

Installation Method

A chalk line, framing square and a miter saw are usually the only tools needed for installation. In most cases, rolling is not necessary. The flooring is adequately adhered by pressure applied as workers walk back and forth over the flooring as it is applied.

A 5% cutting allowance is usually sufficient. The subfloor should be checked for damage, levelness and cleanliness, and corrected if necessary.

First, the installer finds starting point depending on pattern and chalk line in a conventional manner. A "dry" fit of the flooring strip 10 is made to determine necessary cuts. The ends are measured before removing the release paper 27, the ends are dry fitted, then cut, then the release paper 27 is removed to expose the adhesive and the flooring strip 10 is carefully pressed onto the subfloor. The flooring strip 10 is applied to the subfloor along a chalk line, with the groove 18 on the chalk line, and the tongue 19 away from the installer. Other cuts around heat registers, pipes and the like are made as the flooring strips 10 are installed, and before removal of the release paper 27, as described above.

As noted above, marginal areas of the base surface of the flooring strips 10 are not covered with adhesive tape strips 22 and 23. Release paper 27 is removed and the tongue 19 of the flooring strip 10 is introduced into the groove 18 of the adjacent flooring strip 10 at an angle. The absence of adhesive on the marginal area of the base surface 12 adjacent the tongue 19 permits placement of the flooring strip 10 very closely adjacent to the just-laid flooring strip 10 without the just-exposed adhesive contacting the subfloor. The tongue 19 can therefore be inserted completely into the adjacent groove 18 and the flooring strip 10 pressed firmly onto the subfloor in a single motion. The adhesive layer 26 is sufficiently tenacious that the flooring strip should be very substantially in its final position before being pressed to the subfloor.

Shoe molding, radiator pipe flanges and heat register covers are reinstalled. The entire floor is rolled after installation of the flooring strips 10, and the installation is complete.

A flooring strip is described above. Various details of the invention may be changed

without departing from its scope. Furthermore, the foregoing description of the preferred embodiment of the invention and the best mode for practicing the invention are provided for the purpose of illustration only and not for the purpose of limitation--the invention being defined by the claims.

THE EMBODIMENTS OF THE INVENTION IN WHICH AN EXCLUSIVE PROPERTY OR PRIVILEGE IS CLAIMED ARE DEFINED AS FOLLOWS:

1. A wooden flooring strip, comprising:
 - (a) a top surface having a decorative finish;
 - (b) a base surface opposed to said top surface, said base surface having a multiplicity of closely spaced-apart spaces extending into the flooring strip from the base surface transverse to the length of the flooring strip along substantially the entire length of the flooring strip to relieve stress and increase flexibility in the wood strip for more closely adhering to irregularities of a sub-floor;
 - (c) locking means extending along the length of said flooring strip on first and second opposed side edges for locking adjacent flooring strips together side-to-side to form an assembled wood floor, said locking means comprising a tongue formed on said first side edge of the flooring strip and a groove formed in the second side edge of the flooring strip, each of said tongue and groove for mating connection with complementary elements on adjacent flooring strips;
 - (d) said flooring strip having opposing end portions, said end portions each having a single flat area encompassing an entire end portion surface area perpendicular to the plane of the flooring strip for abutting engagement with like flat areas on adjacent flooring strips; and

- (e) at least one strip of pressure sensitive adhesive-coated foam tape applied to the base surface for adhering said flooring strip to the subfloor, and including a protective cover covering said adhesive until removal just prior to installation to the subfloor.
2. A wooden flooring strip according to claim 1, wherein said foam tape includes adhesive on said tape for adhering the tape to the base surface of the flooring strip.
 3. A wooden flooring strip according to claim 2, wherein said foam tape comprises a closed cell polyethylene foam.
 4. A wooden flooring strip as in any one of claims 1 to 3, wherein said adhesive comprises an acrylate pressure sensitive adhesive.
 5. A wooden flooring strip according to claim 4, wherein said flooring strip is selected from the group consisting of solid wood strip, laminated wood strip, solid parquet block and laminated parquet block.
 6. A wooden flooring strip according to claim 1, wherein said adhesive layer is positioned on the base surface of the flooring strip in space-apart relation to both side edges for providing an attachment interface surface for adhering the flooring component to the subfloor while permitting interconnection of the flooring strip with an adjacent, like flooring strip without contact of the adhesive with the subfloor.

7. A wooden flooring strip according to claim 1, wherein said flooring strip includes a top layer, an intermediate layer and a base layer laminated together in registration with each other.
8. A wooden flooring strip according to claim 7, wherein the spaces in the flooring strip are formed by scoring the base layer of the flooring strip.
9. A wooden flooring strip according to claim 7, wherein the spaces in the flooring strip are formed by adhering a plurality of spaced-apart wood pieces in an array to the intermediate layer.
10. A wooden flooring strip according to claim 7, wherein the flooring strip includes two spaced-apart and parallel lengths of foam tape extending along the length of the flooring strip.
11. A wooden flooring strip according to claim 10, wherein said adhesive layer is positioned on the base surface of the flooring strip in spaced-apart relation to both side edges for providing an attachment interface surface for adhering the flooring component to the subfloor while permitting interconnection of the flooring strip with an adjacent, like flooring strip without contact of the adhesive with the subfloor.
12. A wooden flooring strip, comprising:

- (a) a top surface having a decorative finish;
- (b) a base surface opposed to said top surface, said base surface having a multiplicity of closely spaced-apart spaces extending into the flooring strip from the base surface transverse to the length of the flooring strip along substantially the entire length of the flooring strip to relieve stress and increase flexibility in the wood strip for more closely adhering to irregularities of a sub-floor;
- (c) locking means extending along the length of said flooring strip on first and second opposed side edges for locking adjacent flooring strips together side-to-side to form an assembled wood floor, said locking means comprising a tongue formed on said first side edge of the flooring strip and a groove formed in the second side edge of the flooring strip, each of said tongue and groove for mating connection with complementary elements on adjacent flooring strips;
- (d) said flooring strip having opposing end portions, said end portions each having a single flat area encompassing an entire end portion surface area perpendicular to the plane of the flooring strip for abutting engagement with like flat areas on adjacent flooring strips; and
- (e) at least one strip of pressure sensitive adhesive-coated foam tape applied to the base surface for adhering said flooring strip to the subfloor, and including a protective cover covering said adhesive until removal just prior to installation to the subfloor, said

foam tape having a thickness no greater than 10% of the total thickness of the flooring strip.

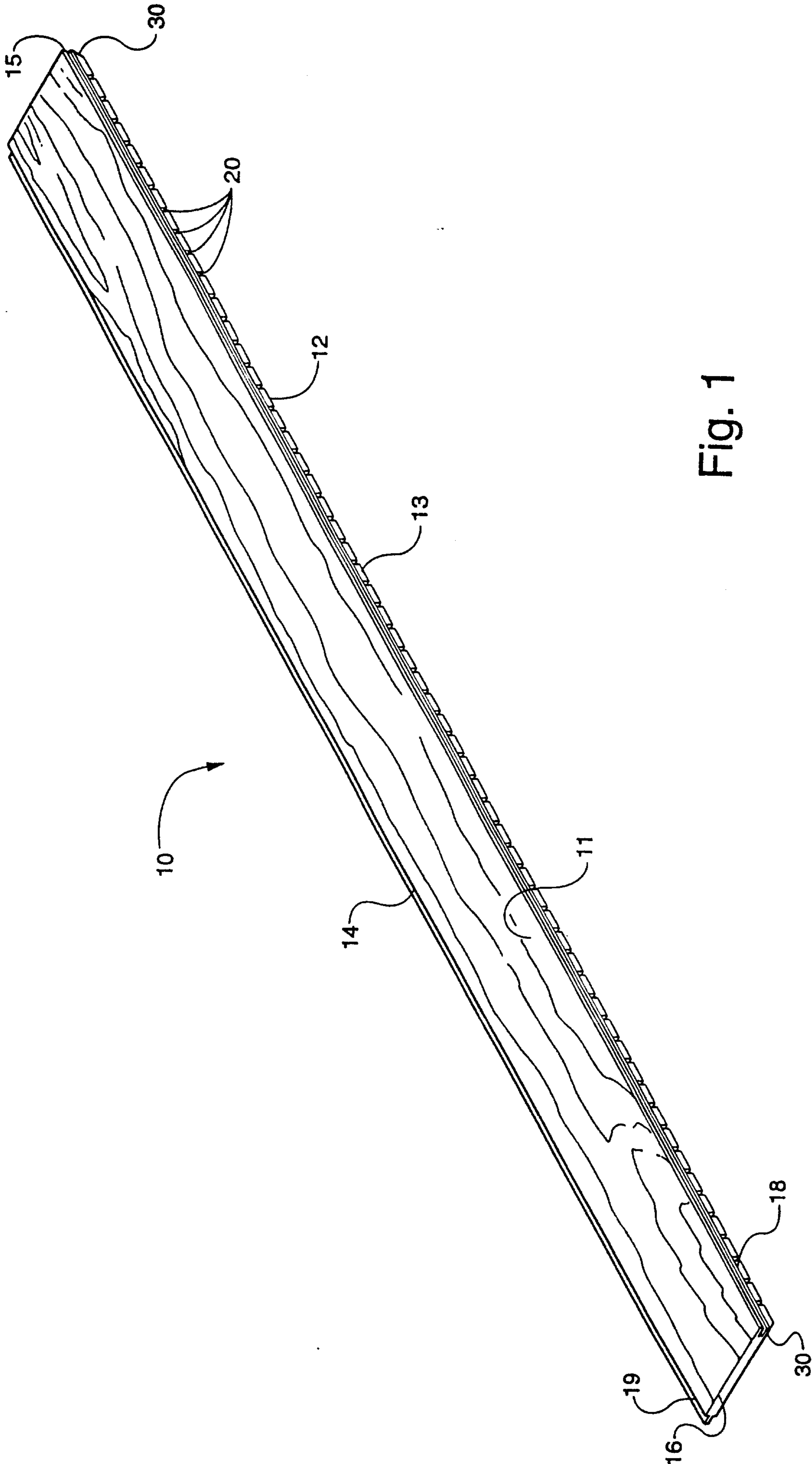

Fig. 1

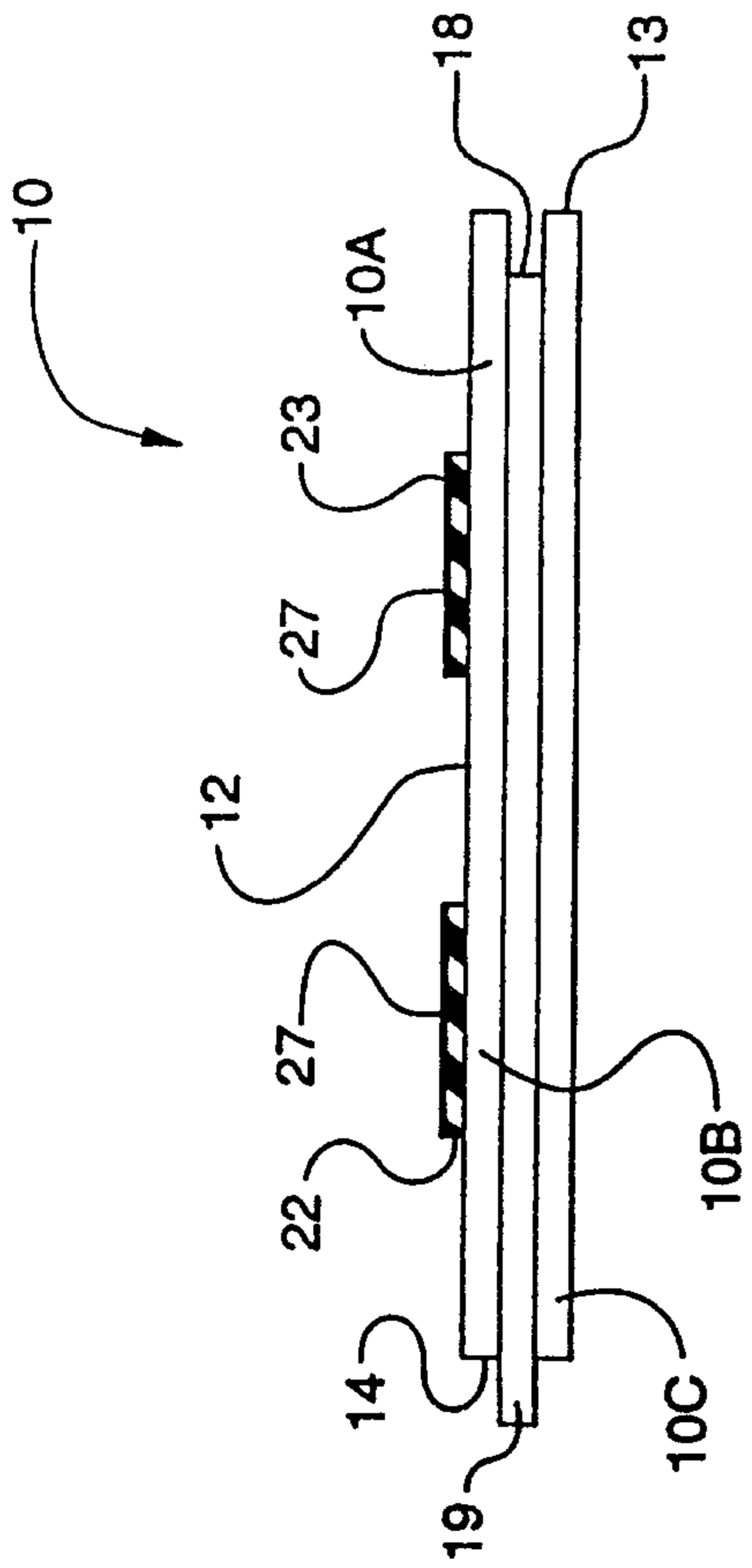

Fig. 3

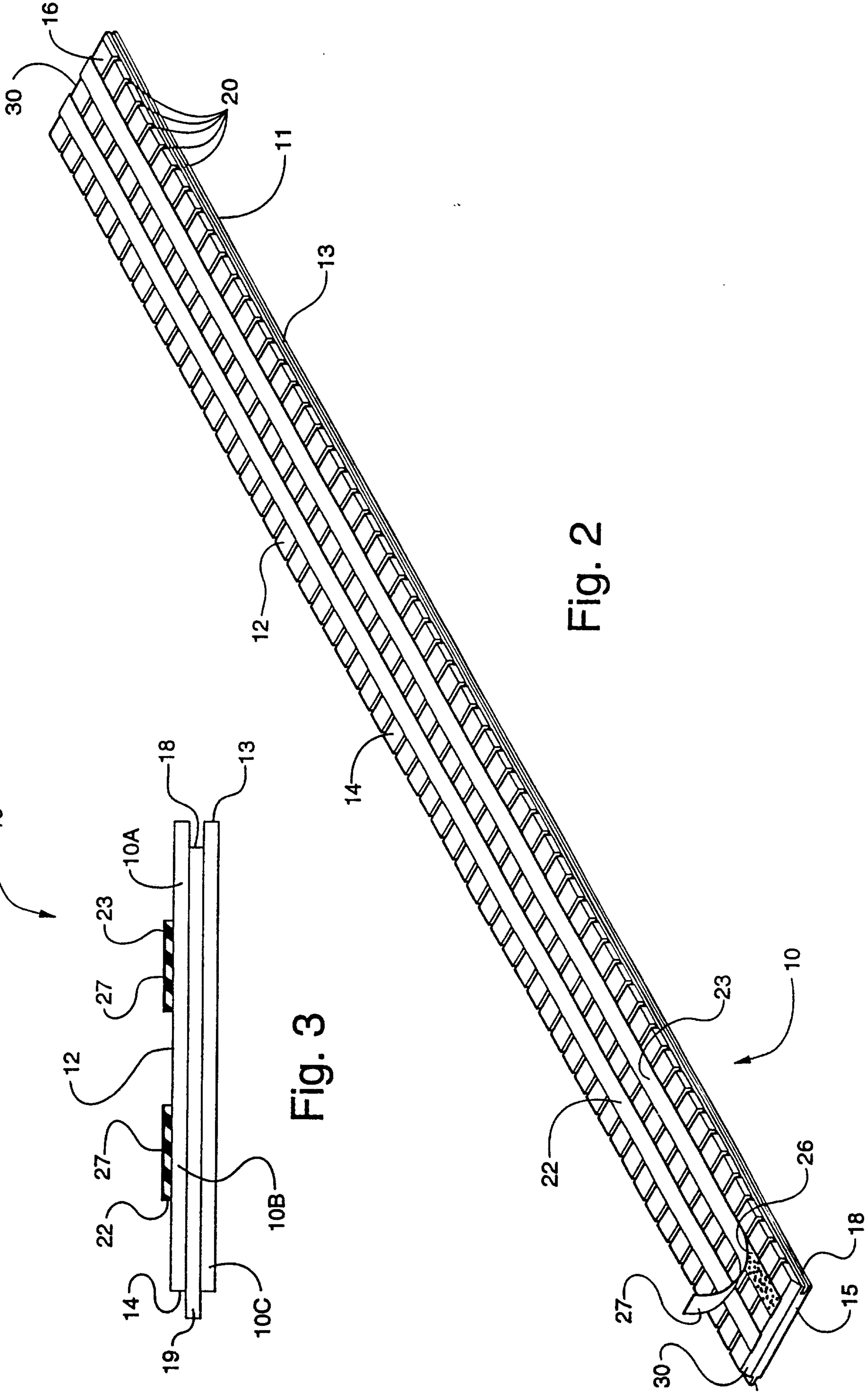

Fig. 2

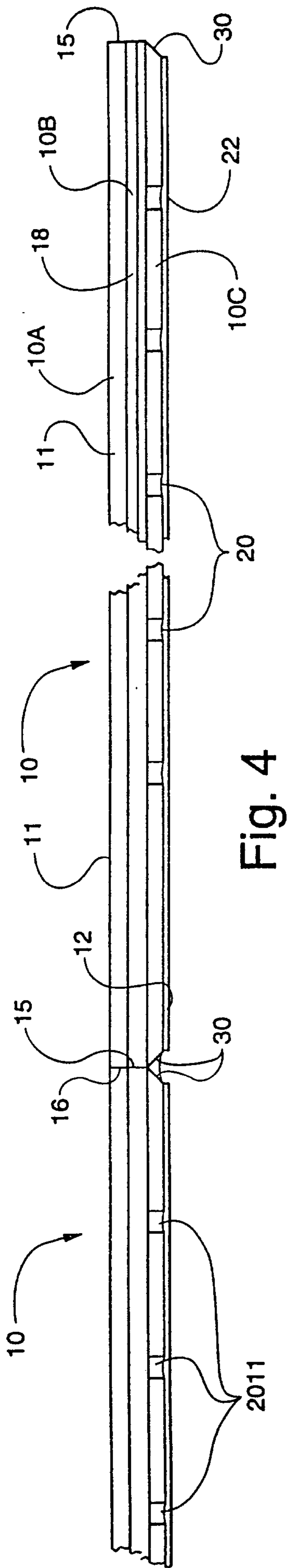

Fig. 4

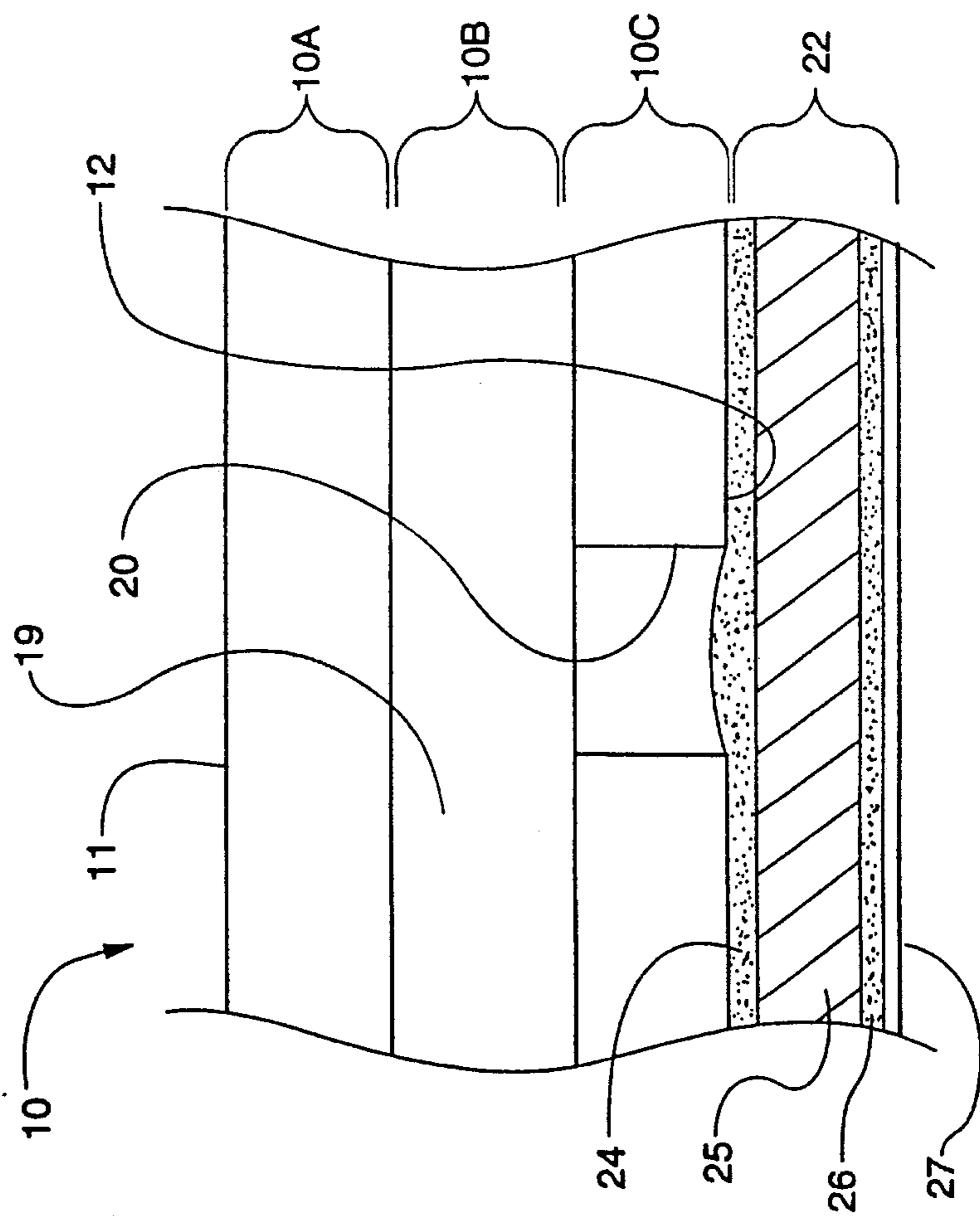

Fig. 5

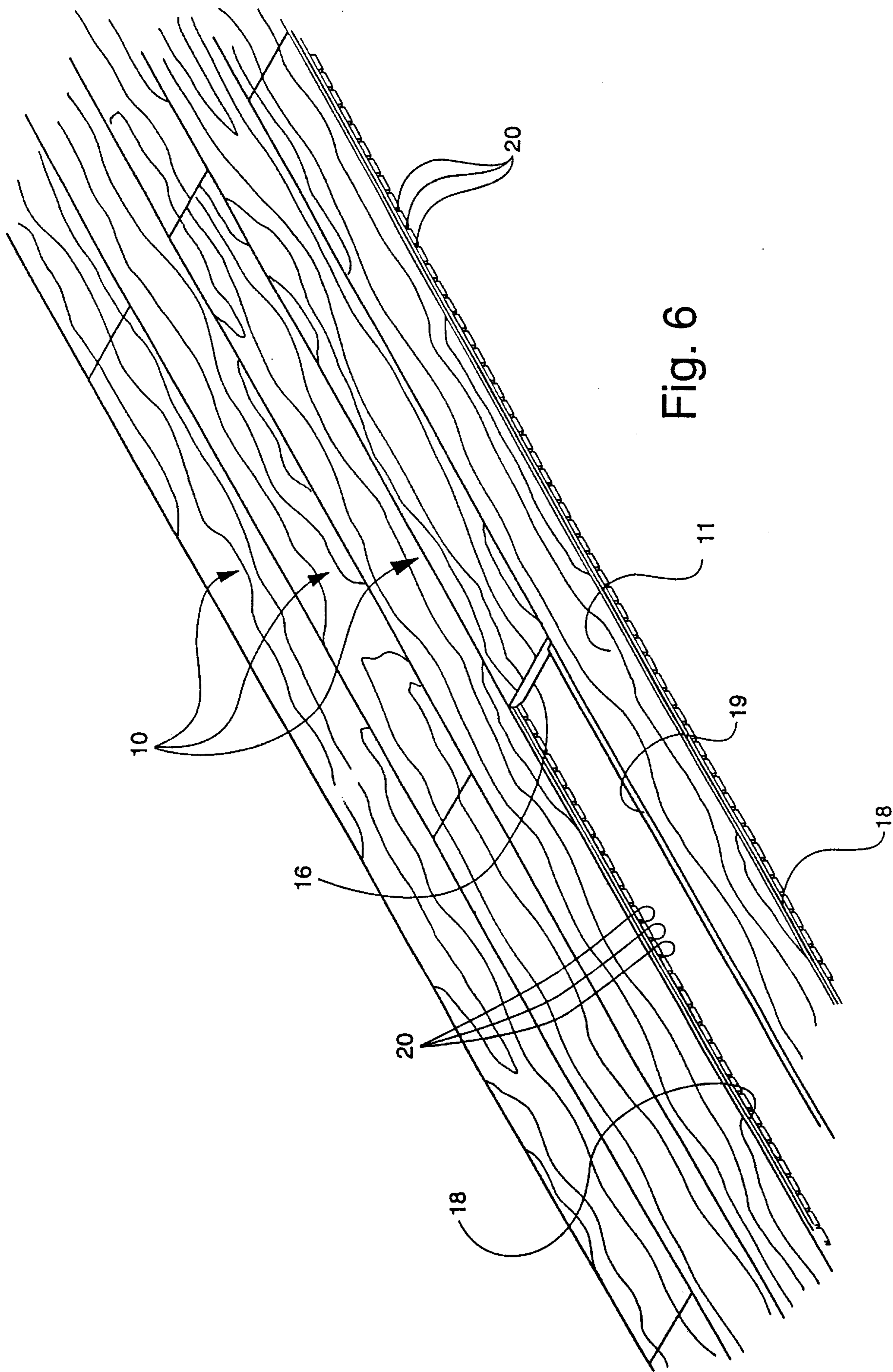

Fig. 6

