

[54] INDUSTRIAL ROBOT

[75] Inventors: Atsuyuki Gotou, Mitaka; Masato Shibayama, Sayama; Takeshi Abe, Tokyo; Ryouichi Hisatomi; Takeshi Sasaki, both of Tochigi, all of Japan

[73] Assignee: Hitachi, Ltd., Tokyo, Japan

[\*\*] Term: 14 Years

[21] Appl. No.: 770,242

[22] Filed: Aug. 28, 1985

[30] Foreign Application Priority Data

Jul. 17, 1985 [JP] Japan ..... 60-30202

[52] U.S. Cl. .... D15/199; D15/122

[58] Field of Search ..... D15/122, 199; 414/729, 414/730, 732, 737, 738, 739, 740, 741, 744 R, 744 A, 744 B, 744 C; 901/14-16

[56] References Cited

U.S. PATENT DOCUMENTS

- D. 268,033 2/1983 Stackhouse ..... D15/122
- D. 273,870 5/1984 Kono et al. .... D15/199

- D. 274,182 6/1984 Kato ..... D15/199
- 3,543,947 12/1970 Devol ..... 414/744 A
- 3,883,009 5/1975 Swoboda, Jr. et al. .... 414/740
- 4,518,307 5/1985 Bloch ..... 414/729
- 4,586,868 5/1986 Nakashima et al. .... D15/199
- 4,594,049 6/1986 Terauchi ..... 414/744 R

Primary Examiner—B. J. Bullock  
Attorney, Agent, or Firm—Antonelli, Terry & Wands

[57] CLAIM

The ornamental design for an industrial robot, as shown.

DESCRIPTION

FIG. 1 is a front, top and left side perspective view of a industrial robot showing our new design; FIG. 2 is a front elevational view thereof; FIG. 3 is a right side elevational view thereof; FIG. 4 is a rear elevational view thereof; FIG. 5 is a left side elevational view thereof; FIG. 6 is a top plan view thereof; FIG. 7 is a bottom plan view thereof; and FIG. 8 is a top plan view of the industrial robot with the arm in another position.

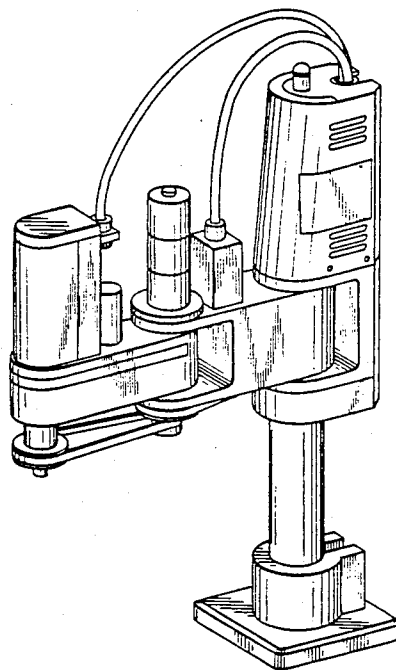

FIG. 2

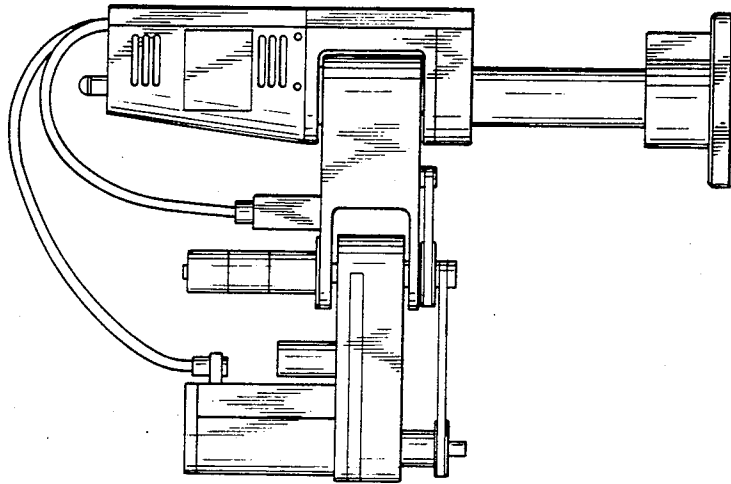

FIG. 1

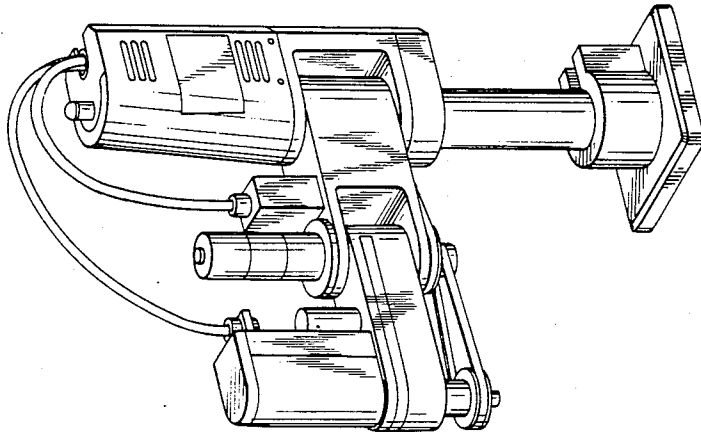

FIG. 5

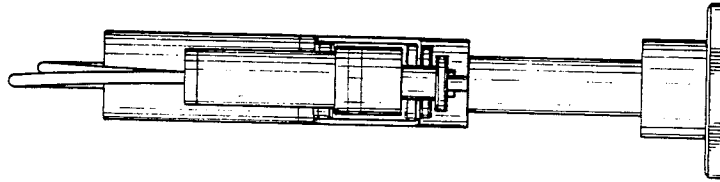

FIG. 4

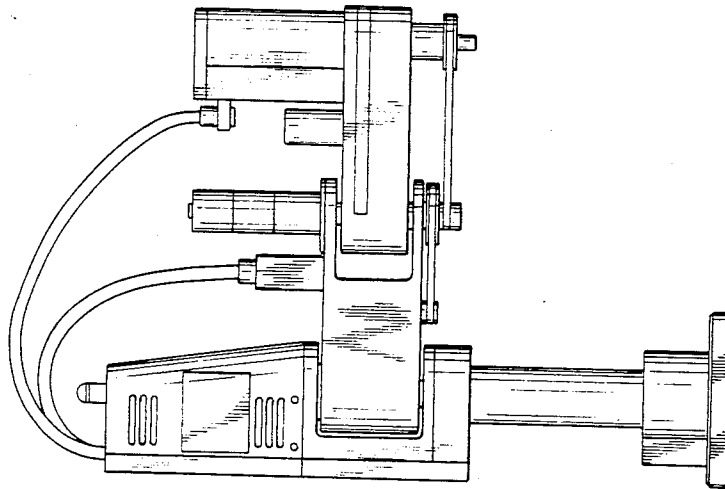

FIG. 3

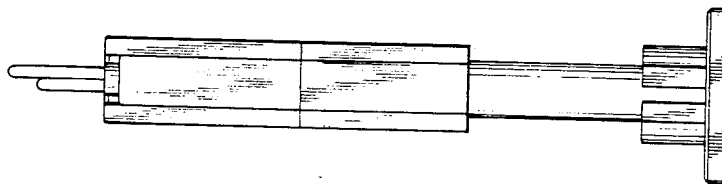

FIG. 6

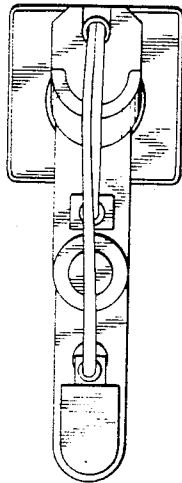

FIG. 7

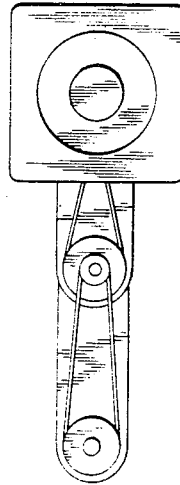

FIG. 8

