

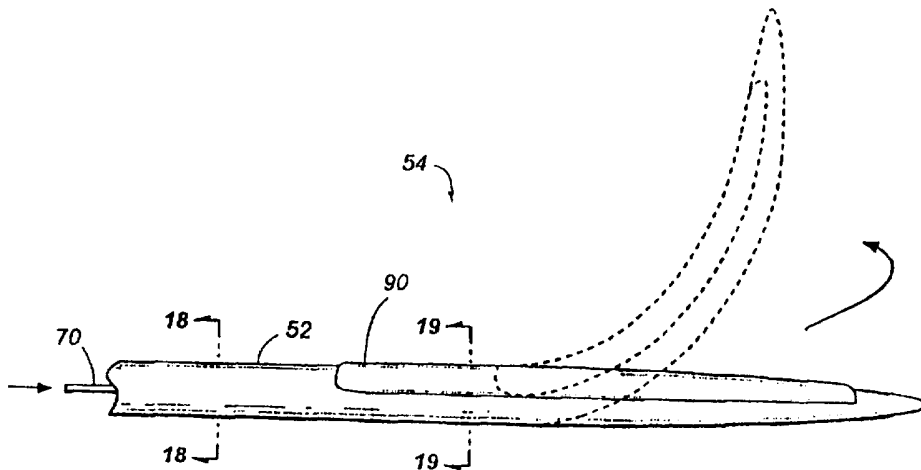

INTERNATIONAL APPLICATION PUBLISHED UNDER THE PATENT COOPERATION TREATY (PCT)

(51) International Patent Classification ⁶ : A61M 25/01	A1	(11) International Publication Number: WO 97/27895 (43) International Publication Date: 7 August 1997 (07.08.97)
<p>(21) International Application Number: PCT/US97/01536</p> <p>(22) International Filing Date: 31 January 1997 (31.01.97)</p> <p>(30) Priority Data: 08/595,736 2 February 1996 (02.02.96) US</p> <p>(71)(72) Applicant and Inventor: KELLEHER, Brian, S. [US/US]; 733 Genter Street, La Jolla, CA 92037 (US).</p> <p>(74) Agents: BERG, Richard, P. et al.; Ladas & Parry, Suite 2100, 5670 Wilshire Boulevard, Los Angeles, CA 90036 (US).</p>	<p>(81) Designated States: AU, CA, JP, European patent (AT, BE, CH, DE, DK, ES, FI, FR, GB, GR, IE, IT, LU, MC, NL, PT, SE).</p> <p>Published <i>With international search report. Before the expiration of the time limit for amending the claims and to be republished in the event of the receipt of amendments.</i></p>	

(54) Title: DEFLECTABLE MEDICAL DEVICE



(57) Abstract

A medical device comprises an elongated, flexible body having a distal end to be inserted into a patient and a proximal end to remain outside the patient. The elongated, flexible body has at least one lumen extending at least partially therethrough, defining a long axis. A control assembly is disposed at the proximal end of the device and is adjacent to the proximal end of the flexible body. An actuating means is disposed within the lumen of the flexible body and may be linked at its proximal end to the control assembly. Manipulation of the control assembly pushes the actuating means in a distal direction, causing the distal end of the actuating means to push on the distal end of the flexible body, thereby placing the flexible body in tension. Restraining means may be disposed within or upon the flexible body to impede stretching in the long axis of certain regions of the flexible body. Controlled deflection of the flexible body in response to the applied tension is achieved by the selective disposition of the restraining means and optional variations in mechanical properties of portions of the flexible body. Means may also be disposed upon or within the flexible body to enhance the torsional stiffness of the flexible body. In one embodiment, the torsional stiffening means may be integrated with the restraining means.

FOR THE PURPOSES OF INFORMATION ONLY

Codes used to identify States party to the PCT on the front pages of pamphlets publishing international applications under the PCT.

AM	Armenia	GB	United Kingdom	MW	Malawi
AT	Austria	GE	Georgia	MX	Mexico
AU	Australia	GN	Guinea	NE	Niger
BB	Barbados	GR	Greece	NL	Netherlands
BE	Belgium	HU	Hungary	NO	Norway
BF	Burkina Faso	IE	Ireland	NZ	New Zealand
BG	Bulgaria	IT	Italy	PL	Poland
BJ	Benin	JP	Japan	PT	Portugal
BR	Brazil	KE	Kenya	RO	Romania
BY	Belarus	KG	Kyrgystan	RU	Russian Federation
CA	Canada	KP	Democratic People's Republic of Korea	SD	Sudan
CF	Central African Republic	KR	Republic of Korea	SE	Sweden
CG	Congo	KZ	Kazakhstan	SG	Singapore
CH	Switzerland	LI	Liechtenstein	SI	Slovenia
CI	Côte d'Ivoire	LK	Sri Lanka	SK	Slovakia
CM	Cameroon	LR	Liberia	SN	Senegal
CN	China	LT	Lithuania	SZ	Swaziland
CS	Czechoslovakia	LU	Luxembourg	TD	Chad
CZ	Czech Republic	LV	Latvia	TG	Togo
DE	Germany	MC	Monaco	TJ	Tajikistan
DK	Denmark	MD	Republic of Moldova	TT	Trinidad and Tobago
EE	Estonia	MG	Madagascar	UA	Ukraine
ES	Spain	ML	Mali	UG	Uganda
FI	Finland	MN	Mongolia	US	United States of America
FR	France	MR	Mauritania	UZ	Uzbekistan
GA	Gabon			VN	Viet Nam

DEFLECTABLE MEDICAL DEVICEBackground of the InventionField of the Invention

5 This invention relates to the field of medical devices and particularly to elongated, flexible medical devices such as guidewires, catheters, endoscopes or endoscopic accessories that benefit from the ability to have their flexible bodies controllably deflected.

Description of the Prior Art

10 Mechanisms for deflecting the bodies of elongated, flexible medical devices are well-known in the art. Such deflecting mechanisms allow an operator to bend a portion of a medical device to a more favorable orientation. For example, in the field of coronary angioplasty, a guidewire is inserted into a
15 circulatory vessel and guided by the operator to a target location. The maneuverability of the guidewire is greatly enhanced by the ability of the operator to selectively deflect the distal tip by means of controls situated at the proximal end of the device.

20 Many such deflection mechanisms operate by means of a control wire extending through a central lumen in the flexible body. The distal end of the control wire is attached to a point near the distal end of the flexible body. By pulling on the control wire, the flexible body is placed in compression and
25 reacts by deflecting in a way that relieves the compression. In some adaptations, the control wire may be disposed in a lumen offset from the central axis of the flexible body, in order to bias bending to a particular side of the flexible body, as in U.S. Pat. Nos. 4,898,577 (Badger) and WO 94/14494 (Savage).

30 Most deflectable medical devices are constructed so as to concentrate deflection to within the distal region of the flexible body, in order to help guide the flexible body around

turns. One method for concentrating deflection near the distal tip is to construct the main length of the flexible body from a relatively stiff tubular member and to fabricate the bending region from a resilient material that more easily deforms in response to the compressive force applied by the control wire. Such constructions are described in U.S. Pat. Nos. 2,574,840 (Pieri) and 2,688,329 (Wallace). The disadvantage of this approach is that a trade-off must be made between the degree to which deflection is concentrated at the tip and the difference in stiffness between the main length and bending region of the flexible body. If the main length of the flexible body is too stiff, it may cause injury to the walls of a vessel through which it must pass. Likewise, if the bending region is too floppy, it may hinder the insertion process. Alternatively, one side of the bending region may be weakened by adding notches or by reducing the material thickness so as to favor bending in that direction when a compressive force is applied by a pull-wire, as in U.S. Pat. No. 4,353,358 (Emerson).

An alternative method is to construct the flexible body using a tightly-wound spring-coil that is laterally flexible but substantially incompressible along its long axis. A control wire extends through the lumen of the spring-coil and is attached to a point near the distal tip. The coil characteristics are typically varied in the distal segment to produce a preferred bending reaction when the control wire is tensioned. For example, in U.S. Pat. No. 3,452,740 (Muller), the coil spacing along one side of the distal segment is wider than the spacing on the opposite side. Alternatively, a stiffening member or strut may be disposed in the distal segment, as in U.S. Pat. No. 3,521,620 (Cook), to cause the distal segment to bend in a certain direction when the control wire is tensioned. Additional examples of such spring-coil deflecting mechanisms can be found in U.S. Pat. Nos. 5,308,324 (Hammerslag), 4,719,924 (Crittendon), and 4,723,936 (Buchbinder). The principal disadvantages of the spring-coil approach are that the coil itself is fragile and expensive to manufacture. Further, the ribbed outer surface of the spring-coil can abrade delicate tissues. Also, for a reusable device

such as endoscopic forceps, the spring-coil is difficult to clean between uses, especially when the spring-coil is not coated with a sealing layer and has widely-spaced coils in the distal region.

5 A different approach to deflection control is to replace the control wire with a pre-curved elastic member slidably disposed within the lumen of the flexible body. By making the bending stiffness of the main length of the flexible body greater than that of the distal region, sliding the elastic member back and forth within the lumen causes the distal region to deflect. Alternatively, a stiffening member or a second pre-curved elastic member may be disposed within the lumen, such that the relative positions of such members controls the amount of deflection. Examples of such mechanisms are disclosed in 10 U.S. Pat. No. 1,913,229 (Bordier) and WO92/14506 (Middleman). While these approaches have the advantage of not needing a spring-coil body, they require a trade-off between flexibility of the main body and the amount of force available for tip deflection.

20 Endoscope-type deflection mechanisms, such as disclosed in U.S. Pat. No. 3,778,304 (Takahashi), utilize a secondary column support around the control wire. The column support, typically a tight-wound spring-coil, extends through a lumen in the flexible body from the control assembly to the proximal edge of 25 the bending region of the flexible body, where the spring-coil is fixedly anchored to the flexible body. The control wire extends from the control assembly through the spring-coil and is attached to the distal end of the flexible body. The control assembly imparts a sliding force to the control wire relative to the spring-coil without putting the flexible body in 30 compression. Thus, pulling on the control wire selectively causes deflection of the bending region of the flexible body. Multiple control wires and column supports are often incorporated into an endoscope to impart multi-axis deflection capability. The disadvantage of this approach is the added 35 complexity and expense of having a secondary column support for the control wire.

In order for elongated, flexible medical devices to be optimally steerable, they not only need to have deflecting means but also means for controlling the radial orientation of the flexible body. Simple twisting of the proximal end of the flexible body generally does not result in an equivalent amount of rotation at the distal end, especially when the flexible body is disposed within a bending passageway such as a circulatory vessel. Transmission of radial motion is improved by increasing the torsional stiffness of the flexible body. Techniques for improving torsional stiffness are well-known in the art and typically involve the addition of torque layers to the flexible body. Examples include U.S. Pat. Nos. 2,962,050 (Ramberg), 3,485,234 (Stevens), 4,425,919 (Alston), 4,586,923 (Gould) and 4,817,613 (Jaraczewski). Materials commonly used for the torque layer include round wire, flat wire and synthetic cord. In U.S. Pat. No. 5,176,660 (Truckai), braided reinforcing strands are helically wound over the flexible body to increase torsional stiffness. Truckai '660 further includes longitudinal strands disposed along the length of the flexible body for increased stiffness to improve pushability. An alternative to the use of stranded torque layers is to apply a thin layer of torsionally-stiff material to the flexible body, as disclosed in U.S. Pat. No. 4,945,920 (Clossick).

Yet another approach to achieving controllable deflection of elongated, flexible devices is disclosed in U.S. Pat. Nos. 3,924,519 (England) and 3,773,034 (Burns), wherein an elastomeric tube has an opening to receive a fluid under pressure. As the pressurized fluid fills the tube, the tube expands. Longitudinal restraining means are disposed along one edge of the tube to restrict expansion on that side, thus causing deflection toward that side. In order to prevent the diameter of the tube from expanding, circumferential restraining strands must be disposed along the tube. This approach offers the potential for a fully-sealed, smooth-surfaced deflectable device that does not need a secondary column support. However, the pressurized fluid presents a safety problem for medical applications. Also, a control system to regulate the fluid pressure is potentially more complicated and expensive than

conventional hand-operated mechanical controls.

While the prior art reveals numerous examples of mechanisms that effectively impart deflectional and rotational capabilities to elongated, flexible medical devices, each of them has at least one undesirable quality in terms of performance, cost, manufacturability or safety. There is, therefore, a need for an improved, flexible medical device having a controllably deflectable portion, and preferably having a torquable body. There is a further need for such a device that may be constructed using relatively few components and few assembly steps.

Summary of the Invention

In accordance with the present invention, there is provided a medical device comprising an elongated, flexible body having a distal end to be inserted into a patient and a proximal end to remain outside the patient. The elongated, flexible body has at least one lumen extending at least partially therethrough, defining a long axis. A control assembly is disposed at the proximal end of the device and is adjacent to the proximal end of the flexible body. An actuating means is disposed within the lumen of the flexible body and may be linked at its proximal end to the control assembly. Manipulation of the control assembly pushes the actuating means in a distal direction, causing the distal end of the actuating means to push on the distal end of the flexible body, thereby placing the flexible body in tension. Restraining means may be disposed within or upon the flexible body to impede stretching in the long axis of certain regions of the flexible body. Controlled deflection of the flexible body in response to the applied tension is achieved by the selective disposition of the restraining means and optional variations in mechanical properties of portions of the flexible body. Means may also be disposed upon or within the flexible body to enhance the torsional stiffness of the flexible body. In one embodiment, the torsional stiffening means may be integrated with the restraining means.

The principal advantage of the present invention over the

prior art is that the actuating means in the present invention uses a pushing force to cause deflection, whereas prior art devices generally rely on a pulling force. By using a pushing force, simpler and less expensive means may be employed for controlling the deflection behavior of the flexible body. For example, a separate column support is not needed in order to concentrate the deflecting force to a desired segment of the flexible body, as is needed in certain prior art devices. Also, certain embodiments of the present invention do not require a different bending stiffness between the main length of the flexible body and the bending region, making the device easier to use and safer for certain applications.

While the mechanical properties and construction of the flexible body may vary depending upon the target application, generally a flexible, medical-grade polymer is extruded to form the tubular structure of the flexible body. The diameter of the lumen of the flexible body is large enough to allow the actuating means to slide freely therethrough. The actuating means is constructed so as to be laterally flexible yet able to support the maximum pushing force applied by the control assembly without deformatively buckling inside the lumen of the flexible body. The control assembly

comprises a mechanism to impart a sliding force to the actuating means relative to the flexible body.

The flexible body optionally incorporates torsional stiffening means to aid in the transmission of torquing motion from the proximal end to the distal end. In one embodiment, such stiffening is accomplished by adding a layer of wrapped filaments. This torque layer may be coated so as to seal and secure the torque layer, or it may be covered with a second layer of material. This second layer may be applied by heat-shrinking, extruding or the like. More than one torque layer may be required to achieve the desired properties of flexibility and torsional stiffness.

Restraining means are disposed within or upon the flexible

body to prevent certain regions of the flexible body from stretching along the long axis in response to tension applied by the actuating means. In one embodiment, the restraining means comprises a layer of material having a higher resistance to stretching than the material used for the tubular structure of the flexible body. This layer may be coextruded with the other layers of the flexible body or it may be extruded separately or applied by adhesive bonding, heat-shrinking, coating or the like. The layer may completely surround the flexible body or it may be applied only to certain portions of the flexible body. In another embodiment, the restraining means comprises one or more filaments disposed in parallel with the long axis of the flexible body. The filaments may be fabricated from wire or cord or may take the form of strips, rods, tubes or the like. The filaments may be applied to the flexible body either during or after extrusion of the tubular structure of the flexible body. In one embodiment, the filaments are applied in conjunction with the application of the torque layer.

The restraining means may be embedded in the flexible body, as in the case of filaments applied during the extrusion process, or the restraining means may be bonded or otherwise attached to the flexible body. Such attachment may occur either along the full length of the restraining means or only at certain points.

By disposing the restraining means in a radially symmetrical pattern along portions of the flexible body, those portions of the flexible body will be restrained from stretching when the flexible body is placed in tension. Deflection properties may be imparted to the unrestrained portions of the flexible body by means well-known to those skilled in the art. By way of example, the unrestrained portion of the flexible body may have one side that is weakened or that is more apt to stretch than the opposite side. Thus, when the flexible body is placed in tension, the weaker side of the unrestrained portion will stretch, causing deflection toward the stronger side.

Alternatively, deflectional properties may be imparted to

the flexible body by disposing the restraining means in a radially asymmetrical pattern along the flexible body. In one embodiment, restraining means are disposed along only one side of the flexible body. Thus, when the flexible body is placed in tension, the unrestrained side of the flexible body stretches, resulting in deflection of the flexible body toward the restrained side. However, such deflection is not concentrated to a particular region of the flexible body.

In order to concentrate the deflection to a particular region, such as the distal tip of the flexible body, the restraining means may be distributed asymmetrically along the length of the flexible body. In one embodiment, restraining means are distributed in a radially symmetrical pattern along the main length of the flexible body, while in the distal region the restraining means are disposed only on one side of the flexible body. Thus, when the flexible body is placed in tension by the actuating means, the only portion of the flexible body that is unrestrained is the unrestrained side of the distal region. As this unrestrained side stretches, the distal region deflects toward the restrained side.

Such a distribution of restraining means may be achieved through various construction techniques. In one embodiment, the restraining means comprises a stretch-resistant layer disposed upon the flexible body. Along the length of the desired bending region, one side of the layer is removed or cut in order to permit stretching on that side. In another embodiment, the restraining means comprises an array of filaments symmetrically distributed radially along the length of the flexible body. In the desired bending region, the filaments on one side are cut to allow stretching on that side.

It will be appreciated that the above-described embodiments offer several advantages over the prior art. First, the tubular structure of the flexible body, the torsional-stiffening means and the restraining means may all be fabricated using conventional extrusion and winding processes, in contrast to the exotic process required for construction of the fine-wire

spring-coil body and column support used in prior art devices. Second, the present invention does not require the use of a pressurized fluid, thus eliminating a safety risk. Third, the restraining means only needs to provide stretch resistance and does not need to withstand a compressive load. Therefore, the restraining means may be constructed of thin filaments that do not substantially alter the bending stiffness of the flexible body. As a result, the bending stiffness of the full length of the flexible body can be consistent, making the device easier and safer to insert through a vessel.

It is among the general objects of the present invention to provide an elongated, flexible medical device that may be controllably deflected.

It is a further object of the present invention to provide a deflectable medical device that has torque transmitting properties.

It is another object of the present invention to provide a deflectable medical device that is relatively simple and inexpensive to construct.

Brief Description of the Drawings

FIG. 1 shows a deflectable medical device constructed in accordance with the present invention;

FIG. 2 is an enlarged, sectional view of the control assembly of the embodiment illustrated in FIG. 1;

FIG. 3 is an enlarged, sectional view of the bending region of the embodiment illustrated in FIG. 1;

FIG. 4 is an enlarged, perspective view of a segment of the flexible body of a different embodiment in accordance with the present invention, with portions broken away to show the underlying layers;

FIG. 5 is an enlarged, perspective view of a segment of the flexible body of yet another embodiment in accordance with the present invention, with portions broken away to show the underlying layers;

FIG. 6 is an enlarged view of the bending region of the flexible body of a different embodiment in accordance with the present invention, showing a second position in phantom;

FIGS. 7 and 8 are sectional views of the embodiment
5 illustrated in FIG. 6;

FIG. 9 is an enlarged view of the bending region of the flexible body of a different embodiment in accordance with the present invention, showing a second position in phantom;

FIG. 10 is a sectional view of the embodiment illustrated
10 in FIG. 9;

FIG. 11 is an enlarged view of the bending region of the flexible body of a different embodiment in accordance with the present invention, showing a second position in phantom;

FIGS. 12 and 13 are sectional views of the embodiment
15 illustrated in FIG. 11;

FIG. 14 is an enlarged view of the bending region of the flexible body of a different embodiment in accordance with the present invention, showing a second position in phantom;

FIGS. 15 and 16 are sectional views of the embodiment
20 illustrated in FIG. 14;

FIG. 17 is an enlarged view of the bending region of the flexible body of a different embodiment in accordance with the present invention, showing a second position in phantom;

FIGS. 18 and 19 are sectional views of the embodiment
25 illustrated in FIG. 17;

FIG. 20 is an enlarged view of the bending region of the flexible body of a different embodiment in accordance with the present invention, showing a second position in phantom;

FIG. 21 is a sectional view of the embodiment illustrated
30 in FIG. 20;

FIG. 22 is an enlarged view of the bending region of the flexible body of a different embodiment in accordance with the present invention, showing a second position in phantom;

FIG. 23 is a sectional view of the embodiment illustrated
35 in FIG. 22;

FIG. 24 is a sectional view of the flexible body of a different embodiment in accordance with the present invention;

FIG. 25 is a sectional view of the flexible body of a different embodiment in accordance with the present invention;

FIG. 26 is an enlarged, perspective view of a segment of the flexible body of yet another embodiment in accordance with the present invention, with portions broken away to show the underlying layers;

5 FIG. 27 is an enlarged view of one of the layers shown in the embodiment illustrated in FIG. 26.

Description of the Preferred Embodiments

10 FIG. 1 shows an elongated, flexible medical device constructed in accordance with the present invention. The device depicted is generic in nature, intended to illustrate only the basic elements of the present invention. The device consists of flexible body 52, having a bending region 54 at its distal end, and control assembly 50 at its proximal end. The length of flexible body will vary depending on the particular application, but may range from several inches to over five feet.

15 FIG. 2 shows an enlarged sectional view of control assembly 50, comprised of plunger 66 and casing 62. Plunger 66 is comprised of thumb ring 56 and shaft 58, with lumen 60 extending through the central axis of shaft 58. Casing 62 comprises rounded flange 64 and lumen 68 extending through its central axis. Shaft 58 is sized to be slidably received by lumen 68. Casing 62 and plunger 66 may be fabricated from impact-resistant plastic such as ABS (acrylonitrile-butadiene-styrene). The proximal end of flexible body 52 is fixedly anchored in lumen 68, using a bonding agent such as epoxy, silicone, urethane or the like. Flexible body 52 has at least one lumen 72 extending therethrough, defining its long axis. For clarity, flexible body 52 is shown without a torque layer or restraining means, as these will be explained and illustrated in more detail later. Actuating means 70 is slidably disposed within lumen 72 and extends through lumen 68 into lumen 60. Actuating means 70 is fixedly anchored in lumen 60 by means of adhesive bonding, crimping, set-screw fixation or the like. Thumb ring 56 and flange 64 are shaped to comfortably receive the thumb and fingers, respectively, of the operator. Squeezing motion of the

operator's thumb and fingers causes shaft 58 to slide into lumen 68, driving actuating means 70 distally into lumen 72. Additional means may be disposed to prevent actuating means 70 from buckling within lumen 68, as is well known to those skilled
5 in the art. Also, a spring-return means may be disposed within lumen 68 or around shaft 58 to cause plunger 66 to return to its proximal position once released. Actuating means 70 may be any structure such as a wire, rod, tube, strip or the like that has both lateral flexibility and the ability to support the maximum
10 compressive load for the particular application. In the embodiments shown, actuating means 70 is preferably made from stainless steel wire having a diameter in the range of .005 to .015 inches.

15 FIG. 3 shows an enlarged, sectional view of bending region 54. The illustration shows provisions to enhance deflection, as these will be discussed and illustrated in later embodiments. Actuating means 70 extends through lumen 72 and may be terminated with cap 74, which may be attached by crimping,
20 bonding, soldering, brazing or the like. Cap 74 serves to prevent actuating means 70 from poking through distal tip 76 of flexible body 52. While cap 74 may be fabricated from a wide range of materials, a radiopaque metal such as gold will assist operators in locating the tip of the device fluoroscopically,
25 which is particularly useful in cardiac catheterization procedures. Cap 74 and actuating means 70 may be fixedly attached within lumen 72 by use of an adhesive such as epoxy, silicone, urethane or the like. As can be seen by referring to FIGS. 2 and 3, pushing plunger 66 into casing 62 drives
30 actuating means 70 distally, which in turn causes flexible body 52 to be placed in tension.

FIG. 4 illustrates a perspective view of a segment of flexible body 52 from a different embodiment of the present invention, with portions broken away to reveal inner layers.
35 Torque layer 82 has been added to the tubular structure of flexible body 52, delineating an inner tubular portion 80 and an outer tubular portion 78. Actuating means 70 is slidably disposed within lumen 72. Torque layer 82 may be constructed

using techniques and materials well known to those skilled in the art. For example, torque layer 82 may be comprised of wrapped wire or cord, or it may be comprised of a layer of thin, flexible material that adds torsional stiffening properties to flexible body 52. In the embodiment illustrated, torque layer 82 is comprised of braided, flat synthetic cord such as Kevlar (trademark of E. I. DuPont, Wilmington, DE). The braided cord must be secured within or around flexible body 52 in order to impart torsional-stiffening characteristics. Such securing may be done by bonding the cord to inner tubular portion 80 or by tightly capturing the cord between outer tubular portion 78 and inner tubular portion 80. Bonding of the braided cord to inner tubular member 80 may be accomplished with a flexible adhesive such as epoxy or urethane. In applications where the diameter of flexible body 52 must be minimized, this adhesive layer may in itself constitute outer tubular portion 78. Otherwise, outer tubular portion 78 may be fabricated from a separate layer of flexible polymer such as urethane, PVC (polyvinyl chloride), fluoropolymer, fluoroelastomer or the like. Alternatively, outer tubular portion 78 may be formed from heat-shrinkable tubing tightly disposed over torque layer 82 so as to securely surround the braided cords. As an alternative to wire or cord, flat metal strips may be wrapped around flexible body 52 to provide torsional stiffening, as is well-known to those skilled in the art of endoscope fabrication.

In most applications, flexible body 52 preferably has a relatively lubricious surface so as to ease the process of inserting the device through a circulatory vessel or through a channel of an endoscope. Since flexible materials such as elastomers often have relatively low lubricity, a trade-off must generally be made between flexibility and lubricity. If adequate lubricity cannot be achieved through material selection alone, outer tubular portion 78 may be subjected to a surface modification or coating process to improve lubricity. Surface modifications to improve lubricity include gas plasma treatment (Polar Materials/Wheaton, Inc., Pennsville, NJ) and ion beam deposition (Spire Corporation, Bedford, MA). Lubricious coatings include parylene (Advanced Surface Technology, Inc.,

Billerica, MA), fluoropolymer (Advance Coating Technology, Mechanicsburg, PA) and various hydrogels (BSI Corporation, Eden Prairie, MN). Likewise, in order for actuating means 70 to slide freely within lumen 72, friction must be minimized between their respective surfaces. Thus, inner tubular portion 80 is preferably extruded from a material having lubricious properties, such as fluoropolymer. Alternatively, lumen 72 or actuating means 70 may be treated as described above to reduce friction. Optionally, an element such as a sleeve having lubricious properties may be disposed between actuating means 70 and lumen 72.

FIG. 5 shows a perspective view of a segment of flexible body 52 from a different embodiment of the present invention, with portions broken away to reveal inner layers. In this embodiment, restraining filaments 84 have been added, disposed about the central axis of flexible body 52 in a radially symmetrical manner. Restraining filaments 84 may be applied as a separate layer to flexible body 52, or, as illustrated, may be integral with the tubular structure of flexible body 52. By way of example, restraining filaments 84 may be inserted through small lumina extruded into the tubular structure of flexible body 52, or they may be embedded directly into the tubular structure during the extrusion process. Restraining filaments 84 may be fabricated from wire, rod, tube, strip or the like that has both adequate flexibility and the ability to support the maximum tensile load for the particular application. Another important consideration is the bond strength between restraining filaments 84 and flexible body 52. As will become more evident in later discussions, each restraining filament must be securely anchored, preferably along its full length, but at least at the proximal and distal ends of the region to be restrained. Bonding may be achieved by use of an appropriate adhesive such as epoxy, cyanoacrylate or the like. Wire, rod or strip filaments are most difficult to bond without significantly roughening their surfaces and may require bending at the ends or attachment to separate proximal and distal anchoring members. Filaments made from cord such as Kevlar are easier to bond to flexible body 52 since the adhesive can penetrate the body of

the cord. Alternatively, an outer layer of material may be extruded or otherwise disposed onto flexible body 52 in such a manner that the molten material penetrates restraining filaments 84, obviating the need for a bonding agent.

5 FIG. 6 shows bending region 54 of an embodiment constructed in accordance with the present invention. The main length of flexible body 52 (the portion from the proximal end anchored in casing 62 to the proximal end of bending region 54), is constructed with torque layer 82 and restraining filaments 84, as best seen in FIG. 7. Restraining filaments 84 are disposed in a radially symmetrical pattern about and in parallel with the long axis of flexible body 52. Torque layer 82 and restraining filaments 84 are not included in bending region 54, as best seen in FIG. 8. As actuating means 70 is pushed distally, flexible body 52 is placed in tension. The main length of flexible body 52 undergoes little stretching due to restraining filaments 84. However, bending region 54 is not restrained and thus undergoes axial stretching. In the embodiment illustrated, the lower edge of bending region 54 is weakened by notches 86, such that the lower side stretches more readily than the top side. Thus, as actuating means 70 is pushed distally, bending region 54 deflects upward, as shown in phantom in FIG. 6. The shape, depth and spatial relationship of notches 86 may be varied to impart different deflection characteristics to bending region 54. As is well-known in the art, various alternative techniques are conceivable for modifying the mechanical properties of bending region 54 to impart the desired deflection behavior, such as thinning the walls or reducing the durometer of the material along bending region 54. A reduction of the durometer of the material may be accomplished by joining one or more extruded sections to the distal end of the main body, each section having a different durometer. Alternatively, flexible body 52 may be formed by a process such as Total Intermittent Extrusion (trademark of Putnam Plastics, Inc., Dayville, CT), wherein the durometer change is incorporated into a continuous length of extruded tubing.

FIG. 9 shows bending region 54 from a different embodiment

constructed in accordance with the present invention. As best seen in FIG. 10, restraining filaments 84 are disposed only along the top edge of flexible body 52. Restraining filaments 84 and torque layer 82 extend throughout the full length of flexible body 52. With this arrangement, pushing on actuating means 70 places flexible body 52 in tension. In response, flexible body 52 stretches axially to relieve that tension. However, due to the restraining filaments 84 on the top side, stretching can only occur on the lower, unrestrained side. Thus, the full length of flexible body 52 deflects upward, as illustrated in phantom in FIG. 9. While this embodiment has the disadvantage of not concentrating deflection to a particular bending region, it may be an acceptable deflection mechanism for devices that are used primarily in conjunction with endoscopes. With such devices, the main length of flexible body 52 is constrained laterally by the channel of the endoscope, allowing the deflection to concentrate mainly within the portion protruding from the tip of the endoscope.

FIG. 11 shows bending region 54 from a different embodiment constructed in accordance with the present invention. As best seen in FIG. 12, restraining filaments 84 are disposed in a radially symmetrical pattern around and in parallel to the long axis of flexible body 52. However, in bending region 54, restraining filaments 84 are only disposed along the top edge, as best seen in FIG. 13. With this arrangement, pushing on actuating means 70 places flexible body 52 in tension. Since the only portion of flexible body 52 that is unrestrained is the lower edge of bending region 54, the result is an upward deflection of bending region 54, as illustrated in phantom in FIG. 11.

FIG. 14 shows bending region 54 from a different embodiment constructed in accordance with the present invention. This embodiment is similar in function to the previous embodiment, with restraining filaments 84 replaced by restraining layer 88. As best seen in FIG. 15, restraining layer 88 is surroundingly disposed over outer tubular portion 78 along the main length of

flexible body 52. In bending region 54, restraining layer 88 is only disposed along the top edge, as best seen in FIG. 16. With this arrangement, pushing on actuating means 70 places flexible body 52 in tension. Since the only portion of flexible body 52 that is unrestrained is the lower edge of bending region 54, the result is an upward deflection of bending region 54, as illustrated in phantom in FIG. 14. Restraining layer 88 is preferably fabricated from a material that is laterally flexible but which is substantially more resistant to stretching than the material used to fabricate the tubular structure of flexible body 52. Appropriate materials include polyester (such as Mylar, trademark of E.I DuPont Co.), polyimide (such as Kapton, trademark of E.I DuPont Co.), polycarbonate, nylon or cellophane. Restraining layer 88 may also be formed from the same classes of polymers suggested previously for fabricating the tubular structure of flexible body 52, but formulated for reduced elasticity. Restraining layer 88 may be a separate element which is bonded or heat-shrunk to flexible body 52, or it may be a layer of extruded material having properties different from those of the tubular structure of flexible body 52. Alternatively, a virtual restraining layer 88 may be formed by a surface treatment applied to flexible body 52 to produce a thin zone of material having decreased elasticity. By way of example, gas plasma polymerization (Advanced Surface Technology, Inc., Billerica, MA) can produce a surface with increased cross-linking and thus reduced elasticity. A further option is to form restraining layer 88 from a coating process.

FIG. 17 shows bending region 54 from a different embodiment constructed in accordance with the present invention. As best seen in FIG. 18, no restraining means are incorporated along the main length of flexible body 52. However, in bending region 54, restraining patch 90 is disposed along the top edge, as best seen in FIG. 19. With this arrangement, pushing on actuating means 70 places flexible body 52 in tension. Since the main length of flexible body is unrestrained, it stretches axially. Within bending region 54, the top edge is constrained by restraining patch 90, while the bottom edge is allowed to stretch. The overall result is a distal shift and an upward

deflection of bending region 54, as illustrated in phantom in FIG. 17. The disadvantage of this approach is that for a given amount of force applied to actuating means 70, relatively little deflection of bending region 54 is achieved.

5 FIG. 20 shows bending region 54 from a different embodiment constructed in accordance with the present invention. As best seen in FIG. 21, no restraining means are incorporated along the main length of flexible body 52. However, in bending region 54, external restraining wire 92 is disposed along the top edge, 10 attached at its distal and proximal ends to flexible body 52. With this arrangement, pushing on actuating means 70 places flexible body 52 in tension. Since the main length of flexible body is unrestrained, it stretches axially. Within bending region 54, the top edge is constrained by external restraining 15 wire 92, while the bottom edge is allowed to stretch. The overall result is a distal shift and an upward deflection of bending region 54, as illustrated in phantom in FIG. 20. While this embodiment tends to produce a greater degree of deflection for a given pushing force on actuating means 70, the 20 disadvantage is that external restraining wire 92 may become snared around a biological or mechanical structure. Also, in a coronary catheter application where flexible body 52 must be guided around turns in small-diameter circulatory vessels, external restraining wire 92 would tend to cut into the vessel 25 wall during deflection.

 FIG. 22 shows bending region 54 from a different embodiment constructed in accordance with the present invention. In contrast with prior embodiments, lumen 72 and actuating means 70 are offset from the central axis of flexible body 52, as best 30 seen in FIG. 23. This offers the improvement of producing a greater amount of deflection for a given amount of pushing force on actuating means 70. Restraining filaments 84 are disposed radially about the central axis of flexible body 52 throughout the full length of flexible body 52. However, those filaments 35 disposed on the lower half of bending region 54, designated as 84a in FIG. 23, are cut at points indicated by arrows "A." Those filaments along the top edge of bending region 54,

designated as 84b in FIG. 23, remain uncut. Thus, the lower edge of bending portion 54 is essentially unrestrained. With this arrangement, pushing on actuating means 70 places flexible body 52 in tension, resulting in an upward deflection of bending region 54, as illustrated in phantom in FIG. 22. Restraining filaments 84a may be cut by slicing through outer tubular portion 78 with a sharp-tipped blade. For applications where exposed cuts in outer tubular portion 78 are undesirable, the cuts may be sealed or entire bending region 54 may be covered with an elastic layer. An alternative approach to cutting restraining filaments 84 is to use a laser. By way of example, the tubular structure of flexible body 52 may be fabricated from an optically clear material and restraining filaments 84 may be formed from a relatively opaque material that will absorb the laser energy and subsequently melt or disintegrate. An option to cutting restraining filaments 84 is to weaken the bond between the filaments and the tubular structure of flexible body 52 within bending region 54. Such weakening may be accomplished by over-stretching bending region 54 to break the bond. Alternatively, for embodiments that require the filaments to be bonded by adhesive to flexible body 52, the adhesive may be deleted or chemically weakened along bending region 54.

FIG. 24 is a sectional view through flexible body 52 of a different embodiment of the present invention. This embodiment is similar to that depicted in FIGS. 9 and 10, except that lumen 72 and actuating means 70 have been offset from the central axis of flexible body 52. By offsetting these elements, a relatively greater amount of deflection is achieved for a given amount of force applied to actuating means 70. As with the embodiment illustrated in FIGS. 9 and 10, this embodiment has the disadvantage of not concentrating the deflection to a particular region.

FIG. 25 is a sectional view through flexible body 52 of a different embodiment of the present invention. In this embodiment, lumen 72, actuating means 70 and restraining filaments 84 are disposed on the lower edge of flexible body 52. Restraining filaments 84 either do not extend through bending

region 54 or are cut in several places along bending region 54. In this embodiment, means must be disposed along bending region 54 to bias the region to deflect in a desired direction when placed in tension, as by notching as illustrated in FIG. 6. Thus, as actuating means 70 is pushed distally, flexible body 52 is placed in tension. Restraining filaments 84 prevent the lower edge of the main length of flexible body 52 from stretching, while entire bending region 54 is allowed to stretch. As a result, a small amount of upward deflection will occur along the main length of flexible body 52, while a greater amount of upward deflection will occur along bending region 54.

FIG. 26 shows a perspective view of a segment of flexible body 52 from a different embodiment of the present invention, with portions broken away to reveal inner layers. In this embodiment, the torque layer and restraining filaments have been combined into an integrated torque/restraining layer 94. FIG. 27 illustrates an enlarged view of torque elements 96 and restraining elements 98, shown interlaced in a triaxial braid pattern. This approach may be used in conjunction with many of the previously-described embodiments, and offers the advantage of simplifying the manufacturing process. Torque elements 96 and restraining elements 98 may be braided as shown or may alternatively be overlaid. Integrated torque/restraining layer 94 may be disposed along the full length of flexible body 52 and subsequently laser-trimmed as described above in order to impart the desired deflection characteristics.

In the embodiments presented thus far, some have shown torque layer 82 terminating at the proximal edge of bending region 54 while others have shown the layer extending through bending region 54. The choice between terminating or extending torque layer 82 depends on the application, as there is a trade-off between bending stiffness and the efficiency of torque transmission. For some applications, the increase in stiffness of bending region 54 caused by the addition of torque layer 82 may not be desirable. For such applications, torque layer 82 may be omitted or its density may be reduced in bending region

54. Additionally, the spatial relationship between elements of the invention, such as the torque layer, restraining means and tubular structure of the flexible body, need not be restricted to the arrangements depicted. By way of example only, the
5 restraining means may be disposed within or around lumen 72, and torque layer 82 may be disposed near the outer surface of flexible body 52. Moreover, the torque layer and restraining means may each consist of a multiplicity of layers or combinations of materials and need not be restricted to the
10 simplified constructions depicted herein. For certain applications, a single layer of appropriate material may function adequately as both a torque-transmitting means and a restraining means, thereby simplifying construction and reducing cost.

15 From the foregoing, it will be appreciated that the present invention provides a deflectable medical device with improvements in accordance with the above-described objects. While particular embodiments of the invention are described herein, it is not intended that the invention be limited exactly
20 thereto, as it is intended that the invention be as broad in scope as the art will permit. Thus, while the embodiments presented describe specific combinations of restraining means, actuating means, torque transmission means, bending region construction and control means, it will be appreciated that the
25 presentation is not intended to be exhaustive. Numerous alternate combinations are readily conceivable to those skilled in the art. Further, while a particular deflectable medical device is disclosed, it will be appreciated that other types of deflectable medical devices, such as guidewires, catheters,
30 cannula, forceps, endoscopes, endoscopic accessories and the like are equally appropriate applications for the improvements encompassing the present invention. For many such applications, the invention disclosed herein will represent a portion of a more complicated device, rather than a stand-alone instrument.
35 In other such applications, supplemental features may be added to the invention disclosed such as additional lumina, more versatile control assemblies, optical waveguides, distal effector mechanisms and the like. Further, it will be appreciated

that multiple actuating means may be incorporated into the invention to impart a multi-axis deflection capability to the device. In addition, while the particular embodiments depicted herein show the distal tip having a closed end, there are
5 equally applicable embodiments that have open-lumen tips to allow passage of a secondary component or fluid through the lumen. Moreover, while various materials are described as being preferred for various parts, it will be appreciated that other appropriate materials may be utilized. Therefore, it will be
10 apparent to those skilled in the art that other changes and modifications may be made to the invention as described in the specification without departing from the spirit and scope of the invention as so claimed.

Although this invention has been disclosed and illustrated
15 with reference to particular embodiments, the principles involved are susceptible for use in numerous other embodiments which will be apparent to persons skilled in the art. The invention is, therefore, to be limited only as indicated by the scope of the appended claims.

CLAIMS

1. A deflectable medical device comprising:
a flexible, elongated body having a distal end and a proximal end and at least one lumen extending at least partially therethrough,
5 said flexible, elongated body having a long axis extending centrally therein between said proximal and distal ends;
an actuating means having a distal end and a proximal end extending at least partially through a lumen of said flexible, elongated body,
10 wherein said distal end of said actuating means is adjacent said distal end of said flexible, elongated body;
a control means attached to the proximal end of said flexible, elongated body, said control means also being linked to said proximal end of said actuating means,
15 whereby activation of said control means pushes on said proximal end of said actuating means in a distal direction relative to said flexible, elongated body, placing said flexible, elongated body in tension;
20 restraining means disposed within or upon said flexible, elongated body, said restraining means being relatively more resistant to stretching in an axis parallel to said long axis than said flexible, elongated body,
whereby said restraining means restricts portions of said flexible, elongated body from stretching in response to said applied tension;
25 wherein the combination of said applied tension and said restraining means results in lateral deflection of at least a portion of said flexible, elongated body.
- 30 2. A deflectable medical device according to claim 1 further comprising torque transmitting means disposed along said long axis of said flexible, elongated body.
- 35 3. A deflectable medical device according to claim 2 wherein said torque transmitting means comprises at least one array of torque-transmitting filaments wrapped around and along

said long axis of said flexible, elongated body.

4. A deflectable medical device according to claim 3 wherein said restraining means is comprised of an array of restraining filaments, said restraining filaments being
5 integrated with said array of torque transmitting filaments.

5. In a deflectable medical device according to claim 4 wherein said integrated torque transmitting and restraining filaments are disposed in a triaxial braid configuration.

6. A deflectable medical device according to claim 2
10 wherein said torque transmitting means comprises at least one layer of polymeric material surroundingly disposed along said long axis of said flexible, elongated body.

7. A deflectable medical device according to claim 2
15 wherein said torque transmitting means comprises a combination of layers of polymeric material surroundingly disposed along said long axis of said flexible, elongated body and arrays of filaments wrapped around and along said long axis of said flexible, elongated body.

8. In a deflectable medical device according to claim 2
20 wherein said torque transmitting means is formed by modifying the physical properties of the surface of said flexible, elongated body.

9. In a deflectable medical device according to claim 8
25 wherein said modification of the physical properties of the surface of said flexible, elongated body is accomplished by a gas plasma process.

10. In a deflectable medical device according to claim 8
30 wherein said restraining means is also formed by modifying the physical properties of the surface of said flexible, elongated body.

11. A deflectable medical device according to any one of the proceeding claims wherein said restraining means comprises

at least one filament disposed in parallel with said long axis of said flexible, elongated body.

5 12. A deflectable medical device according to claim 11 wherein the restraining capability of at least one of said at least one filament is compromised along at least a portion of the length of said at least one filament.

13. A deflectable medical device according to claim 12 wherein said reduction in restraining properties of said filaments is achieved by cutting said filaments.

10 14. A deflectable medical device according to claim 13 wherein a laser is used to cut said filaments.

15 15. A deflectable medical device according to any one of the proceeding claims wherein said restraining means comprises an array of filaments disposed in a radially symmetrical pattern about and in parallel with at least a portion of said long axis of said flexible, elongated body.

20 16. A deflectable medical device according to any one of claims 1-14 wherein said restraining means comprises an array of filaments disposed in a radially asymmetrical pattern about and in parallel with at least a portion of said long axis of said flexible, elongated body.

17. A deflectable medical device according to any one of the proceeding claims wherein said restraining means is integrated into the wall of said flexible, elongated body.

25 18. A deflectable medical device according to any one of the proceeding claims wherein said restraining means is bonded to said flexible, elongated body.

30 19. A deflectable medical device according to any one of claims 11-18 wherein said flexible, elongated body includes at least one additional lumen extending parallel to said long axis, wherein said at least one restraining filament is disposed

within said at least one additional lumen.

20. A deflectable medical device according to any one of the proceeding claims wherein said restraining means comprises a layer of material disposed in parallel with said long axis of said flexible, elongated body.

21. A deflectable medical device according to claim 20 wherein said layer of material is disposed in a radially symmetrical pattern about and in parallel with at least a portion of said long axis of said flexible, elongated body.

22. A deflectable medical device according to claim 20 wherein said layer of material is disposed in a radially asymmetrical pattern about and in parallel with at least a portion of said long axis of said flexible, elongated body.

23. A deflectable medical device according to claim 20 wherein said layer of material is embedded in said flexible, elongated body.

24. A deflectable medical device according to claim 20 wherein said layer of material is bonded to said flexible, elongated body.

25. A deflectable medical device according to claim 20 wherein said layer of material is coextruded with at least a portion of said flexible, elongated body.

26. A deflectable medical device according to any one of the proceeding claims wherein said lumen is concentric with said long axis of said flexible, elongated body.

27. A deflectable medical device according to any one of claims 1-25 wherein said lumen is offset from said long axis of said flexible, elongated body.

28. A deflectable medical device according to any one of the proceeding claims wherein said flexible, elongated body has

a bending region;

wherein a plane intersecting said long axis of said flexible, elongated body divides said bending region into a first half and a second half;

5 wherein the mechanical properties of said first and second halves are different, such that said first half is less resistant to stretching in the direction of said long axis than said second half.

10 29. A deflectable medical device according to claim 28 wherein said difference in mechanical properties of said first and second halves of said bending region is a difference in the geometries of the two halves.

15 30. A deflectable medical device according to claim 28 wherein said difference in mechanical properties of said first and second halves of said bending region is a difference in the material properties of the two halves.

20 31. In a deflectable medical device according to any one of the proceeding claims wherein said restraining means is formed by modifying the physical properties of the surface of said flexible, elongated body.

32. In a deflectable medical device according to claim 31 wherein said modification of the physical properties of the surface of said flexible, elongated body is accomplished by a gas plasma process.

25 33. A device comprising:
a hollow body,
a lumen in the hollow body, the lumen having an elongate axis,
an actuator extending through the lumen in the hollow body,
30 first means operatively coupled to the hollow body for positioning the hollow body,
second means for operating upon the actuator to move the actuator in the direction of the elongate axis, and
third means for providing a controlled bending of the

hollow body in accordance with the movement of the actuator.

34. A device as set forth in claim 33, wherein
the actuator is operatively coupled to the hollow body, and
the third means is operable on the hollow body in
5 accordance with the movements of the actuator to provide greater
movements of the hollow body at first positions transverse to
the elongate axis than at second positions transverse to the
elongate axis to produce a controlled bending of the hollow body
and the actuator.

10 35. A device as set forth in claims 33 or 34, wherein
the hollow body is bendable at particular positions along
the elongate axis relatively removed from the third means, and
the third means provides a bending of the hollow body at
the particular positions in accordance with the movements of the
15 actuator.

36. A device as set forth in any one of claims 33-35,
further including
means disposed on the hollow body for torsionally
stiffening the hollow body.

20 37. A device as set forth in any one of claims 33-36,
wherein
the hollow body is bendable at particular positions along
the elongate axis relatively removed from the third means,
the third means provides a bending of the hollow body at
25 the particular positions in accordance with the movements of the
actuator, and further including
fourth means disposed on the hollow body for torsionally
stiffening the hollow body.

30 38. A device as set forth in claim 37, further including
means disposed on the hollow body for providing a
controlled bending of the hollow wire in a particular direction
in accordance with the movements of the actuator, the fourth
means being disposed on the hollow body at positions further
displaced from the first means than the third means.

39. A device as recited in any one of claims 33-38, wherein

5 the hollow body has notches at its periphery at the positions of the controlled bending for providing the controlled bending in a direction away from the notches.

40. A device as set forth in any one of claims 33-39, wherein

10 the hollow body is constructed to place one portion of the periphery of the body in a particular direction relative to the elongate axis, under a greater tension than another portion of the periphery of the hollow body in the particular direction, in accordance with the movement of the actuator to provide the bending of the hollow body in the direction of the portion of the periphery of greater tension.

15 41. A device as set forth in any one of claims 33-40, wherein

the hollow body has a portion disposed partially around the first means for providing a bending of such portion of the hollow body in accordance with the movements of the actuator.

20 42. A device as set forth in any one of claims 33-41, wherein

25 the hollow body has restraining means attached to a portion for providing a bending of the hollow body in a direction dependent upon the position of attachment of the restraining means to such portion of the hollow body.

43. In combination:

a hollow body having a lumen extending along a elongate axis,

30 an actuator disposed in the lumen and coupled to the hollow body at a first end of the actuator,

first means disposed on the hollow body at a position displaced from the first end of the actuator for retaining the hollow body in a fixed relationship, and

35 second means retained by the first means for movement relative to the first means along the elongate axis and

operatively coupled to the actuator for moving the actuator along the elongate axis,

the hollow body being bendable at the first end of the lumen in accordance with the movement of the actuator.

5 44. In a combination as set forth in claim 43,
the lumen constituting a first lumen,
the hollow body having a second lumen displaced along the
long axis from the first lumen and the second means being
10 disposed in the second lumen of the hollow body in slidable
relationship to the hollow body.

 45. In a combination as set forth in claims 43 or 44,
the lumen in the hollow body being co-axial with the hollow
body along the long axis,
the actuator being disposed in the lumen in the hollow body
15 in co-axial relationship with the hollow body.

 46. In a combination as set forth in any one of claims 43-
45,
the lumen in the hollow body being disposed in a non-
coaxial relationship with the hollow body,
20 the actuator being disposed in the lumen in a non-coaxial
relationship with the hollow body to bend the hollow body in
accordance with the movements of the actuator.

 47. In a combination as set forth in any one of claims 43-
6,
25 means disposed on the hollow body for providing a torsional
stiffness to the hollow body.

 48. In a combination as set forth in any one of claims 43-
47,
third means disposed on the hollow body for providing a
30 torsional stiffness to the hollow body, and
fourth means disposed on the hollow body at positions
further removed from the first means than the third means for
providing a greater tension on one side of the hollow body
relative to the elongate axis than on the other side of the

hollow body relative to the elongate axis to provide a bending of the hollow body in accordance with the movements of the actuator,

5 the hollow body being unbalanced relative to the actuation on one side of the elongate axis of the hollow body with respect to the other side of the elongate axis of the hollow body.

49. In a combination as set forth in any one of claims 43-48, wherein

10 the hollow body has a bending region and wherein a plane intersecting the long axis of the hollow body divides the bending region into a first half and a second half and wherein

15 the mechanical properties of the first and second halves are different such that the first half is less resistant to stretching than the second half.

50. In combination:

20 a hollow body having a elongate axis,
there being a lumen in the hollow body along the elongate axis of the hollow body,
an actuator disposed in the lumen in the hollow body,
first means disposed on the hollow body for retaining the hollow body,

25 second means positioned by the first means and movable relative to the first means along the elongate axis and operatively coupled to the actuator for pushing the actuator along the elongate axis,

30 the actuator being coupled to the hollow body to exert a force on the hollow body in accordance with the pushing provided on the actuator along the elongate axis by the second means,

the force exerted by the actuator on the hollow body being greater on one side of the hollow body relative to the long axis than the force exerted by the actuator on the other side of the hollow body relative to the elongate axis to provide a bending of the hollow body and the actuator.

35 51. In a combination as set forth in claim 50,
the actuator being disposed in a non-concentric

relationship with the hollow body in a plane substantially orthogonal to the long axis of the hollow body.

52. In a combination as set forth in claim 51 wherein the actuator is disposed closer to the periphery of the hollow body on one side of the hollow body than to the periphery of the hollow body on the other side of the hollow body and wherein

at least one restraining element is disposed on the hollow body on one of the sides of the hollow body.

53. In a combination as set forth in claims 50 or 52, the hollow body being constructed to be stretched by the movements of the actuator more easily on the one side of the hollow body relative to the long axis of the hollow body than on the other side of the hollow body relative to the elongate axis of the hollow body to provide a bending of the hollow body.

54. In a combination as set forth in any one of claims 50-53, the hollow body being notched on one of the sides of the hollow body.

55. In a combination as set forth in any of claims 50-54, third means disposed on the hollow body for torsionally stiffening the hollow body.

56. In a combination as set forth in any one of claims 50-55, third means disposed on the hollow body at first positions for torsionally stiffening the hollow body and preventing the hollow body from bending, and fourth means disposed on the hollow body at second positions for providing for the production of the greater force on the one side of the hollow body relative to the long axis than the force on the other side of the hollow body relative to the long axis,

the second positions being further removed from the first means than the first positions.

57. In a combination as set forth in claim 56 wherein the third means includes at least one restraining element disposed at the first positions on the hollow body at both sides of the hollow body.

5 58. In a combination as set forth in claim 57 wherein the fourth means includes at least one restraining element disposed at the second positions on the hollow body at one of the sides of the hollow body.

10 59. In a combination as set forth in an one of claims 50-58 wherein means are provided on the hollow body for providing for the production of the greater force on the one side of the hollow body relative to the long axis than the force on the other side of the hollow body relative to the long axis.

15 60. In a combination as set forth in claim 59 wherein the last-mentioned means includes at least one restraining element disposed at one of the sides of the hollow body.

20 61. In combination for use in a cavity in a patient, a hollow body having a long axis, there being a lumen in the hollow body along the long axis of the hollow body, an actuator disposed in the lumen in the hollow body for pushing along the long axis, control means operatively coupled to the hollow body and
25 the actuator for positioning the hollow body near one end of the actuator and for providing a pushing of the actuator along the long axis relative to the positioning of the hollow body, the actuator being coupled to the hollow body near the other end of the actuator to exert a force on the hollow body in
30 accordance with the pushing of the actuator along the long axis, the force exerted by the actuator on the hollow body being greater on one side of the hollow body relative to the long axis than the force exerted by the actuator on the other side of the hollow body relative to the long axis to provide a bending of
35 the hollow body and the actuator.

62. In a combination as set forth in claim 61,
the actuator being disposed in a non-concentric
relationship with the hollow body in a plane substantially
orthogonal to the long axis of the hollow body.

5 63. In a combination as set forth in claim 61,
the hollow body being constructed to be stretched by the
movements of the actuator more easily on one of the sides of the
hollow body relative to the long axis than on the other of the
transverse sides of the hollow body relative to the long axis to
10 provide a bending of the hollow body.

64. In a combination as set forth in claim 61,
the hollow body being notched on one of the sides of the
hollow body.

15 65. In a combination as set forth in claim 61,
third means disposed on the hollow body for torsionally
stiffening the hollow body.

20 66. In a combination as set forth in claim 61,
third means disposed on the hollow body at first positions
for torsionally stiffening the hollow body and preventing the
hollow body from bending, and

fourth means disposed on the hollow body at second
positions for providing for the production of the greater force
on the hollow body relative to the long axis than the
25 force on the other side of the hollow body relative to the long
axis,

the second positions being further removed from the first
means than the first positions.

30 67. In a combination as set forth in claim 66 wherein
the third means includes at least one restraining
element disposed at the first positions on the hollow body at
both sides of the hollow body relative to the long axis.

68. In a combination as set forth in claim 61 wherein

third means are provided on the hollow body for providing for the production of the greater force on one side of the hollow body relative to the long axis than the force on the other side of the hollow body relative to the long axis.

5 69. In a combination as set forth in claim 68 wherein the third means includes at least one restraining element disposed at one of the sides of the hollow body relative to the long axis.

10 70. In a combination as set forth in claim 62 wherein the actuator is disposed closer to the periphery of the hollow body on one side of the hollow body relative to the long axis than to the periphery of the hollow body on the other side of the hollow body relative to the long axis and wherein

15 at least one restraining element is disposed on the hollow body on one of the sides of the hollow body relative to the long axis.

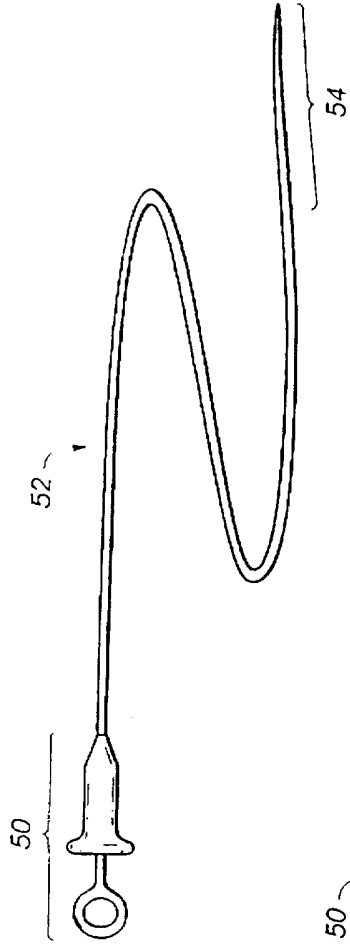

Fig. 1

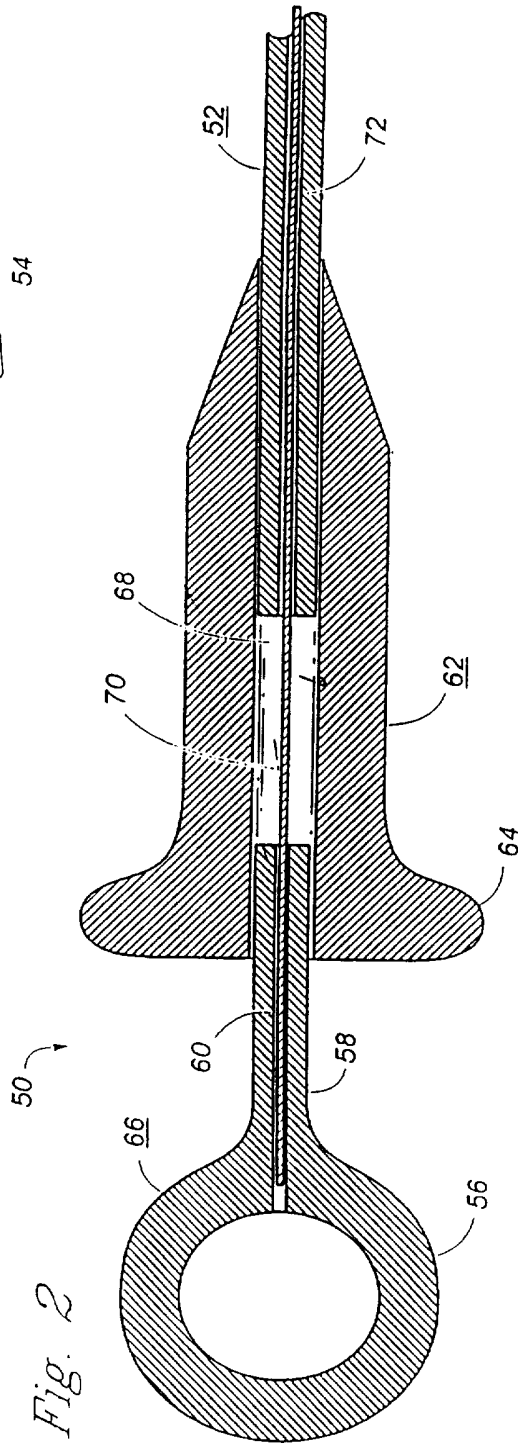

Fig. 2

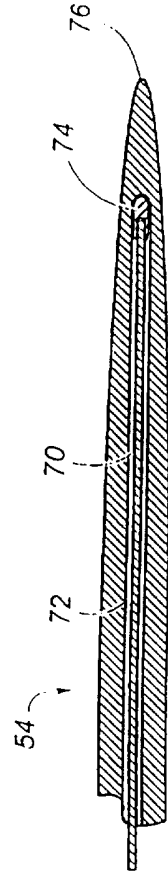

Fig. 3

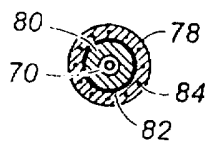
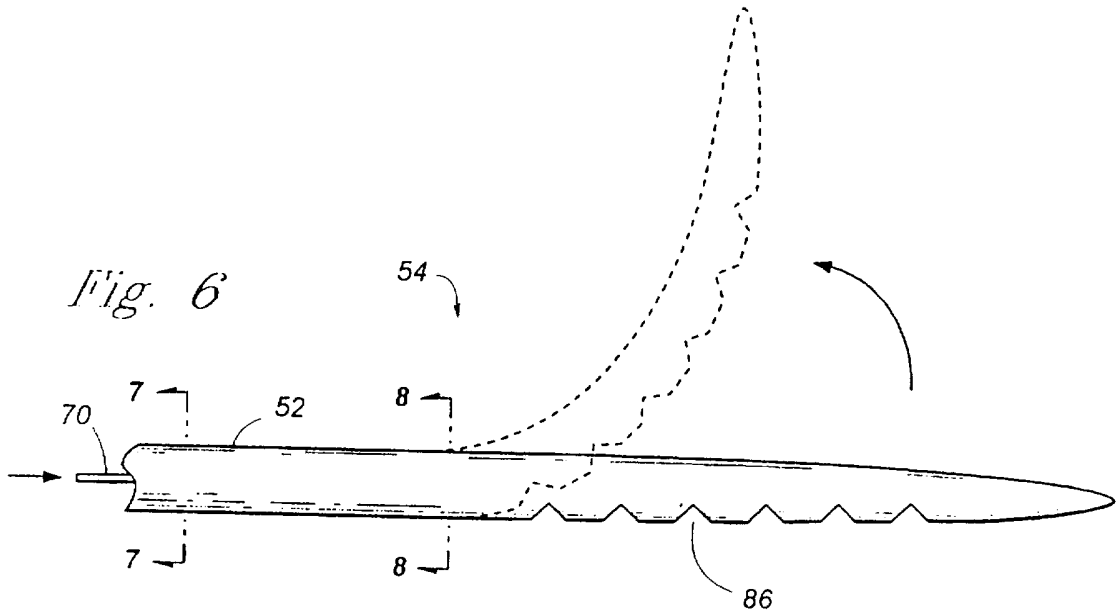
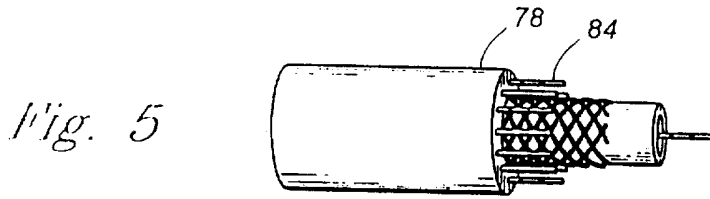
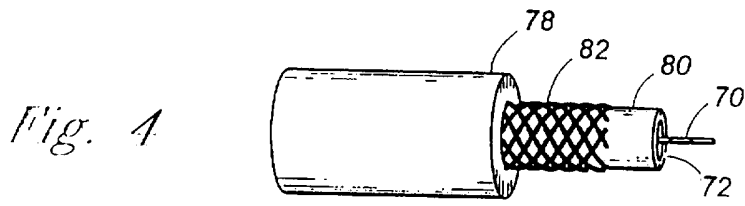

Fig. 7

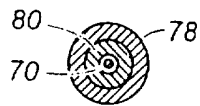

Fig. 8

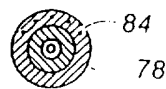
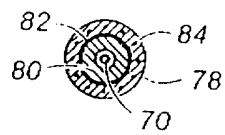
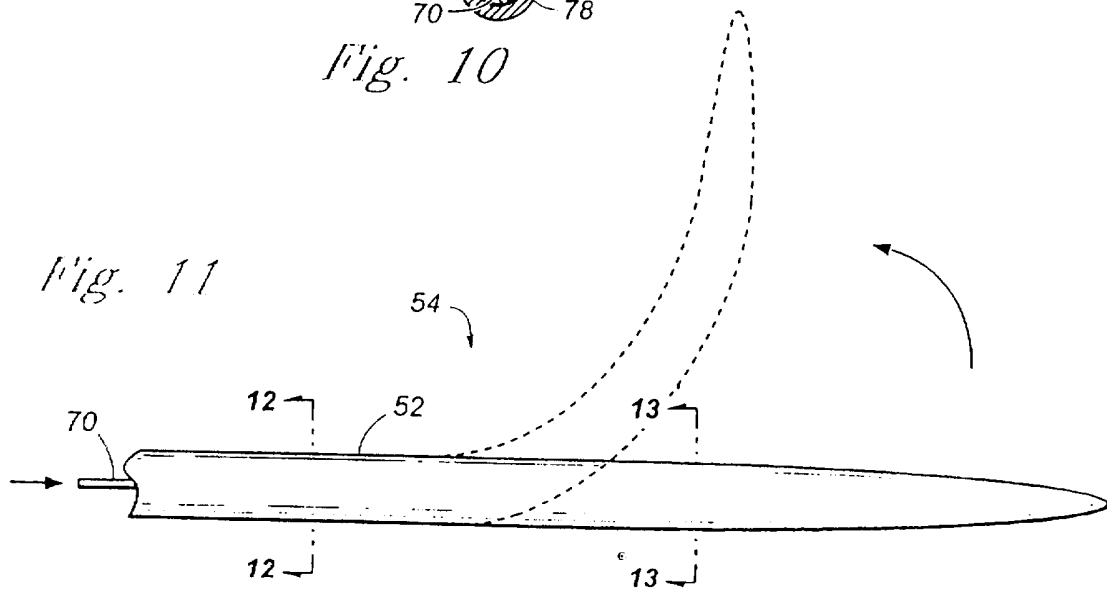
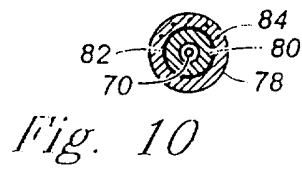
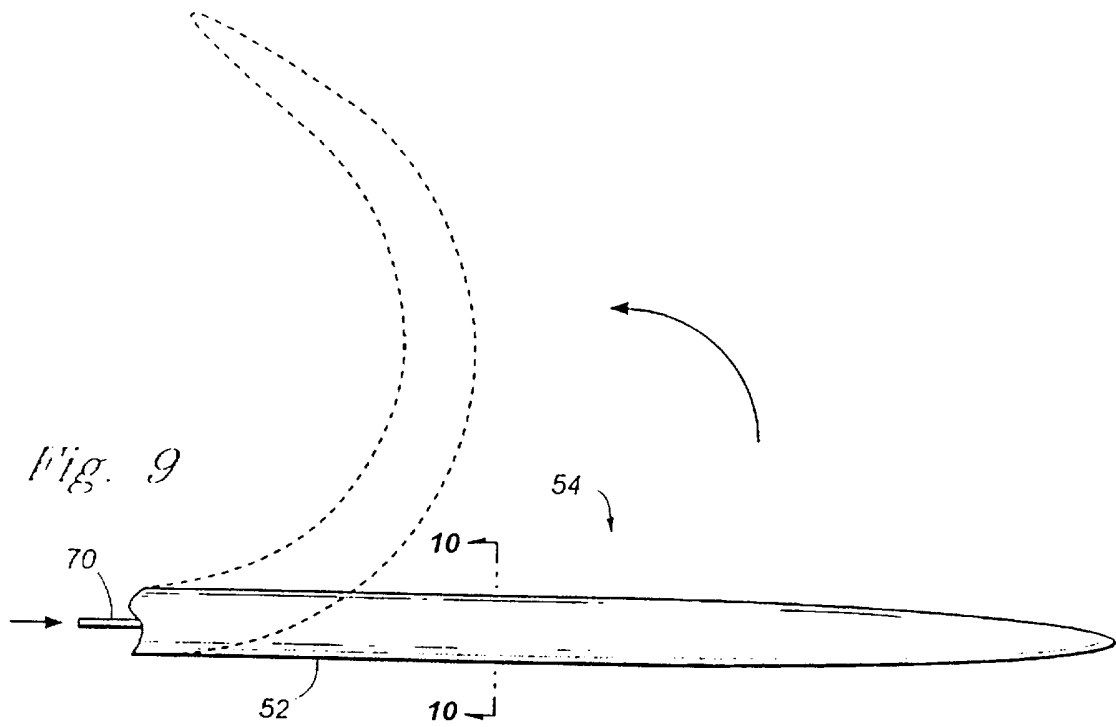
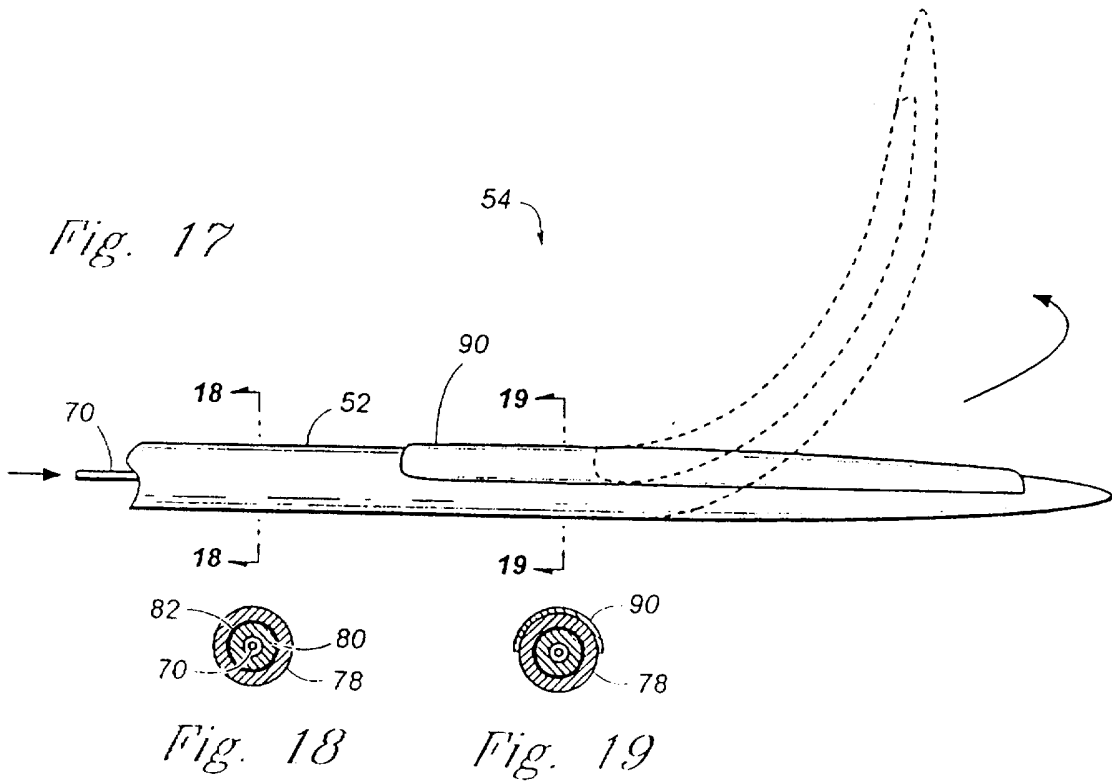
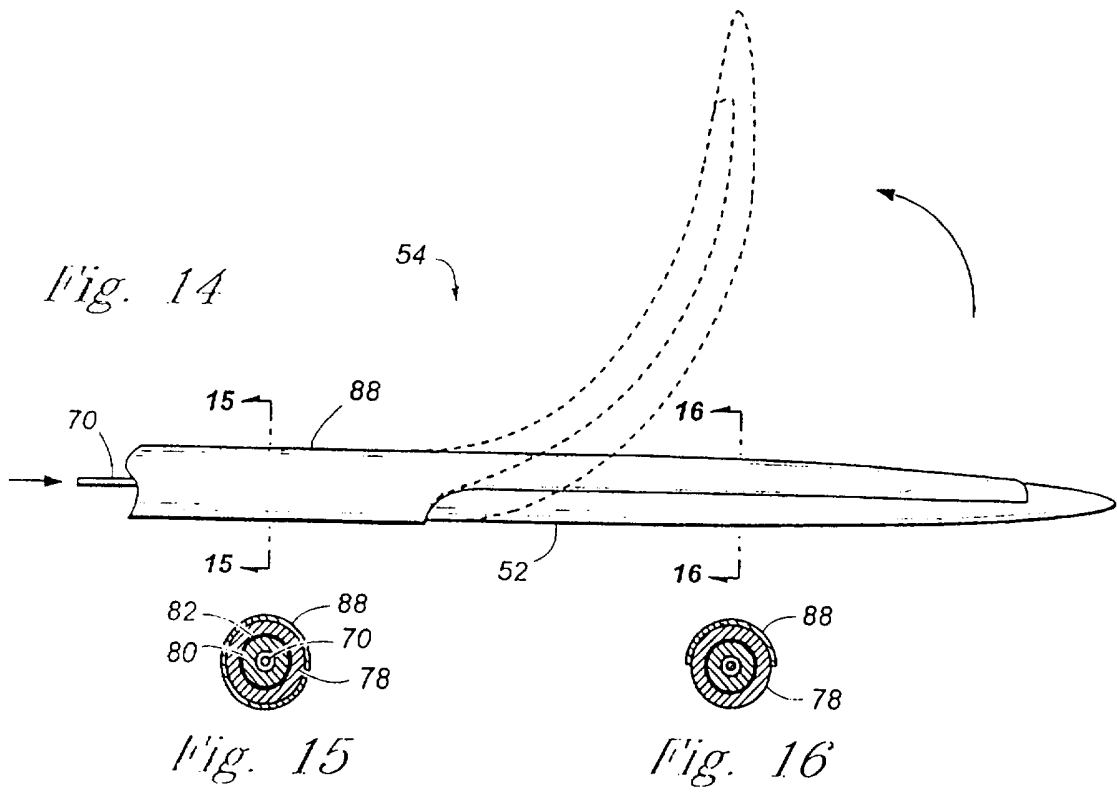

Fig. 12

Fig. 13



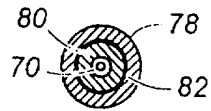
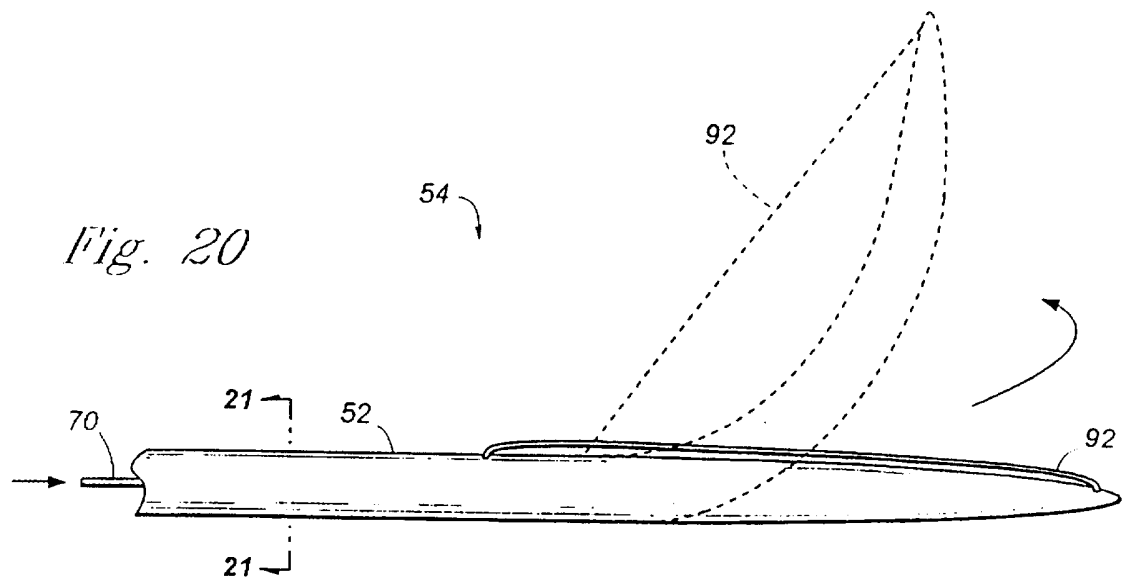

Fig. 21

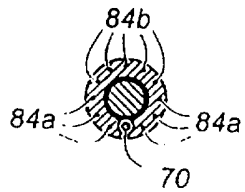
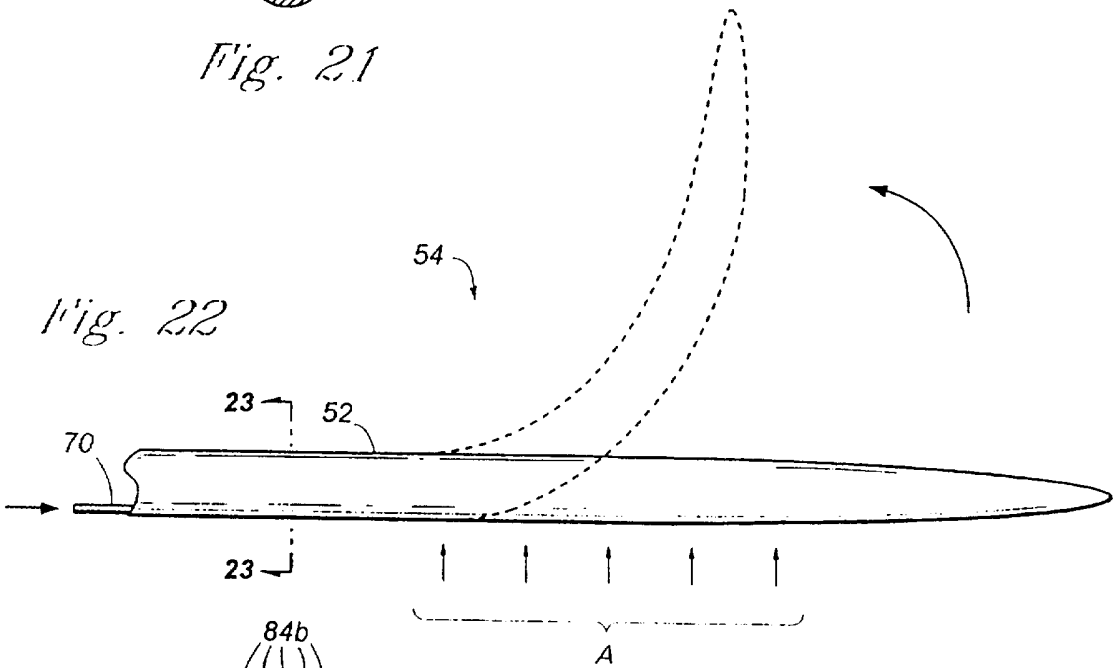

Fig. 23

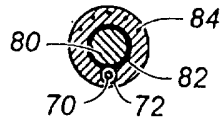

Fig. 24

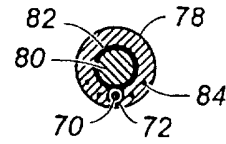

Fig. 25

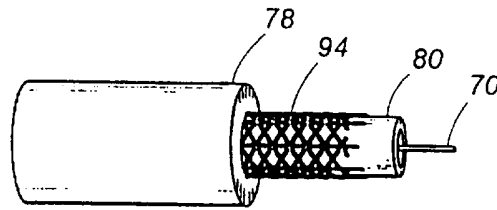

Fig. 26

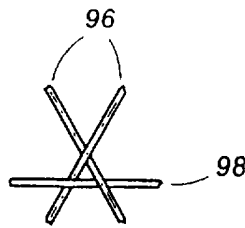

Fig. 27

INTERNATIONAL SEARCH REPORT

International Application No

PCT/US 97/01536

A. CLASSIFICATION OF SUBJECT MATTER
IPC 6 A61M25/01

According to International Patent Classification (IPC) or to both national classification and IPC

B. FIELDS SEARCHED

Minimum documentation searched (classification system followed by classification symbols)
IPC 6 A61M A61B

Documentation searched other than minimum documentation to the extent that such documents are included in the fields searched

Electronic data base consulted during the international search (name of data base and, where practical, search terms used)

C. DOCUMENTS CONSIDERED TO BE RELEVANT

Category *	Citation of document, with indication, where appropriate, of the relevant passages	Relevant to claim No.
X	WO 95 01204 A (CONCEPTUS) 12 January 1995 see page 4, line 27 - page 8, line 15; figures ---	1-4,6,8, 10-12, 18-20, 23-25, 27,28, 30,31, 33-40, 42,43, 46-70
X	US 5 318 526 A (COHEN) 7 June 1994 see column 4, line 58 - column 6, line 24; figures ---	33-44, 46-49 1-7,15, 17,20, 50-70
	-/--	

Further documents are listed in the continuation of box C.

Patent family members are listed in annex.

* Special categories of cited documents :

- *A* document defining the general state of the art which is not considered to be of particular relevance
- *E* earlier document but published on or after the international filing date
- *L* document which may throw doubts on priority claim(s) or which is cited to establish the publication date of another citation or other special reason (as specified)
- *O* document referring to an oral disclosure, use, exhibition or other means
- *P* document published prior to the international filing date but later than the priority date claimed

- *T* later document published after the international filing date or priority date and not in conflict with the application but cited to understand the principle or theory underlying the invention
- *X* document of particular relevance; the claimed invention cannot be considered novel or cannot be considered to involve an inventive step when the document is taken alone
- *Y* document of particular relevance; the claimed invention cannot be considered to involve an inventive step when the document is combined with one or more other such documents, such combination being obvious to a person skilled in the art.
- * & * document member of the same patent family

Date of the actual completion of the international search

12 June 1997

Date of mailing of the international search report

20. 06. 97

Name and mailing address of the ISA

European Patent Office, P.B. 5818 Patentlaan 2
 NL - 2280 HV Rijswijk
 Tel. (+ 31-70) 340-2040, Tx. 31 651 epo nl,
 Fax (+ 31-70) 340-3016

Authorized officer

Kousouretas, I

INTERNATIONAL SEARCH REPORT

International Application No
PCT/US 97/01536

C.(Continuation) DOCUMENTS CONSIDERED TO BE RELEVANT

Category *	Citation of document, with indication, where appropriate, of the relevant passages	Relevant to claim No.
X	EP 0 689 851 A (CORDIS) 3 January 1996	33-35,
		40,43,
A	see the whole document	45,49
		1,8,10,
		11,20,
A	EP 0 630 657 A (OSYPKA) 28 December 1994	23,25,
	see abstract; figures	50,61
A	US 4 846 175 A (FRIMBERGER) 11 July 1989	33,43
	see column 1, line 64 - column 2, line 22;	
	figures	

INTERNATIONAL SEARCH REPORT

Intern. Application No
PCT/US 97/01536

Patent document cited in search report	Publication date	Patent family member(s)	Publication date
WO 9501204 A	12-01-95	US 5391146 A AU 7210594 A	21-02-95 24-01-95

US 5318526 A	07-06-94	NONE	

EP 689851 A	03-01-96	NL 9401107 A	01-02-96

EP 630657 A	28-12-94	DE 4320962 A US 5484407 A	05-01-95 16-01-96

US 4846175 A	11-07-89	DE 3643362 A DE 3777135 A EP 0274705 A JP 63288150 A	23-06-88 09-04-92 20-07-88 25-11-88
