

J. M. CORNELL.  
DEVICE FOR BALANCING TOOL BARS.

APPLICATION FILED FEB. 10, 1903.

2 SHEETS—SHEET 1.

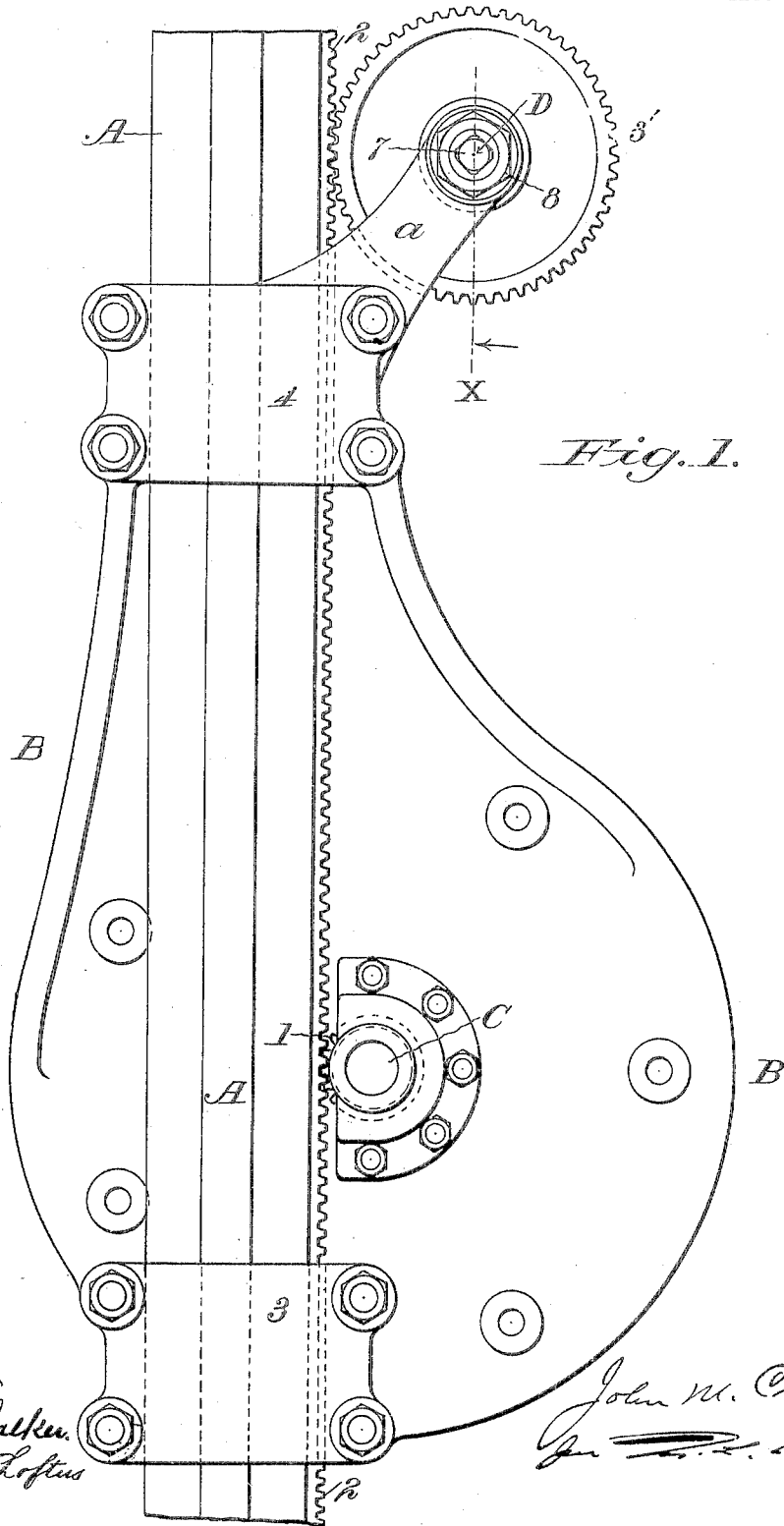

*Fig. 1.*

Witnesses  
*Chas. H. Walker.*  
*E. P. Hest. Loftus*

Inventor,  
*John M. Cornell*  
*J. H. Davis,*  
Attorney.



# UNITED STATES PATENT OFFICE.

JOHN M. CORNELL, OF NEW YORK, N. Y.

## DEVICE FOR BALANCING TOOL-BARS.

SPECIFICATION forming part of Letters Patent No. 793,873, dated July 4, 1905.

Application filed February 10, 1903. Serial No. 142,744.

*To all whom it may concern:*

Be it known that I, JOHN M. CORNELL, a citizen of the United States of America, and a resident of the borough of Manhattan, New York city, in the State of New York, have invented a new and useful Improvement in Devices for Balancing Tool-Bars, of which the following is a specification.

This invention relates to means for supporting the weight of the tool-post or tool-bar in boring-mills and in other machines which have depending tool-bars. This has heretofore commonly been done by counterweights and chains, which destroy the appearance of the machine.

The object of the present invention is to render it practicable to dispense with such weights and chains and to balance the tool-bar by means of a peculiarly-applied spring, also to provide for inclosing such spring and for regulating its tension.

The invention consists in certain novel combinations of parts hereinafter set forth and claimed.

Two sheets of drawings accompany this specification as part thereof.

Figure 1 of the drawings is a side view of a portion of a boring-mill, showing the location and application of the improved balancing device. Fig. 2 is another fragmentary elevation of the same, partly in section, on the line X, Fig. 1; and Fig. 3 is a fragmentary elevation projected from Fig. 2.

Like letters and numbers refer to like parts in all the figures.

In carrying this invention into effect the depending tool-bar A may be made of any required length and raised and lowered by any known or improved mechanism. The housing B of power mechanism for raising and lowering the bar is shown in Fig. 1 and a portion of the same in Fig. 2. The central shaft of said mechanism is represented at C in Fig. 1. A pinion 1, Fig. 1, on said shaft C meshes a rack 2 on one side of the tool-bar A, as in Fig. 1, to connect the tool-bar with the raising and lowering mechanism. A pair of guides 3 and 4 are conveniently formed on said housing B as guides for the tool-bar A. In connection with the cap of the uppermost,

4, of said guides a bracket a is formed, so as to project at a suitable angle at the top of said housing, and a companion bracket b is attached to the opposite side of said housing, as in Fig. 2. Said bracket b and the parts carried thereby are shown by Fig. 3. A horizontal shaft D, mounted in said brackets a and b, supports at one end the hollow elongated hub c of a spur-wheel 3', in mesh with said rack 2, and the other end of said hub c is embraced and supported within the upper extremity of said bracket b, as in Fig. 2. A spiral spring E of sufficient strength and of any required length is inclosed within said hub c and is securely fastened at its respective ends 5 and 6 to the partly-closed end of the hub c, adjacent to the bracket a, and to a ratchet-wheel d, integral with or fast on the other end of said shaft D within the bracket b. (See Fig. 2.) One end of the shaft D, protruding through the bracket a, is squared, as shown at 7, to receive a hand-crank by which to tighten the spring E and is provided with a screw-nut 8, by which to fasten the shaft in the brackets a and b. The ratchet-wheel d at the other end of the shaft D is meshed by a pawl e, which is attached to the bracket b and pivoted by a screw f. It will be apparent that by turning the shaft D by means of a hand-crank applied thereto and by taking up such movement of the shaft by means of the pawl and ratchet e and d the tension of the spring E may be readily regulated, so that it will balance the weight of the tool-bar A and obviate the use of counterweights for this purpose. A horizontal bearing 9 for a rock-shaft forming part of the boring-mill is conveniently made integral with the bracket b and is so shown in Figs. 2 and 3. This detail forms no part of the present invention and need not, therefore, be further described or illustrated.

The term "spiral spring" is herein employed as defined in *Knight's American Mechanical Dictionary*.

Other forms of coil-springs may be used as substitutes for the preferred spiral form without wholly departing from my invention, and other like modifications will suggest themselves to those skilled in the art.

Having thus described said improvement, I claim as my invention and desire to patent under this specification—

1. The combination with a depending tool-  
5 bar, provided with a longitudinal rack, of a spur-wheel in mesh with said rack, having a hollow elongated hub, partly closed at one end, a spiral balancing-spring coiled within  
10 said hub and connected therewith at said partly-closed end, a longitudinal shaft fixedly supported within said hub and surrounded by said spring, said shaft having a square and a fastening nut at one end, and at its other  
15 end a ratchet-wheel fast thereon to which the other end of the spring is connected, a pawl in mesh with said ratchet-wheel, and a pair of supporting-brackets, embracing respectively the squared end of said shaft, and the open end of said hub of the spur-wheel, sub-  
20 stantially as hereinbefore specified.
2. The combination with a depending tool-

bar provided at one edge with a longitudinal rack, and with mechanism for raising and lowering said bar including a pinion in mesh with said bar, of a housing for said mechan- 25  
ism provided with guides for said bar, a pair of brackets one of which is supported by the cap of the uppermost of said guides, a spur-wheel in mesh with said rack having a hollow elongated hub supported by and between 30  
said brackets, a spiral balancing-spring coiled within said hub and connected therewith at one end, a longitudinal shaft within said hub supported by said brackets and surrounded  
35 by said spring, and means for turning said shaft to tighten said spring, substantially as hereinbefore specified.

JOHN M. CORNELL.

Witnesses:

VERNON F. SMITH,  
CHAS. J. EVANS.