

(No Model.)

2 Sheets—Sheet 1.

S. H. DYER.
SEWING MACHINE.

No. 584,543.

Patented June 15, 1897.

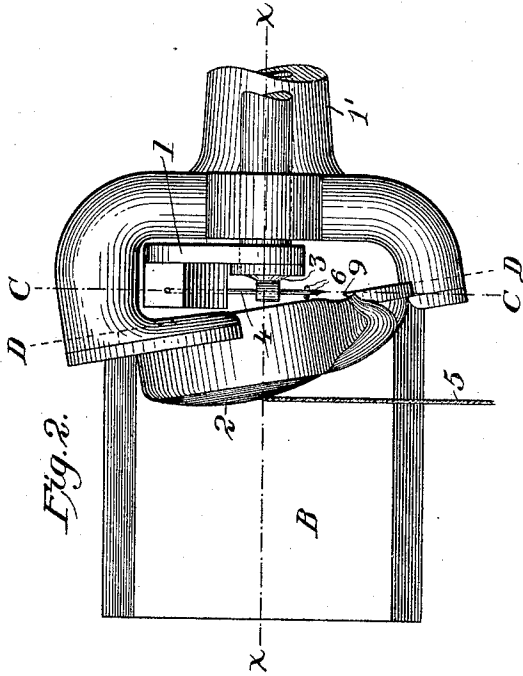

Fig. 2.

Fig. 4.

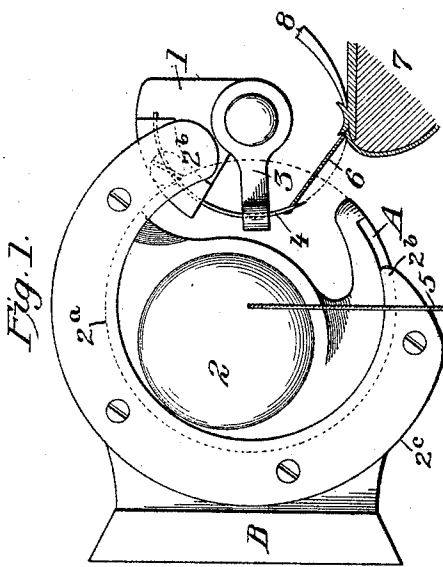
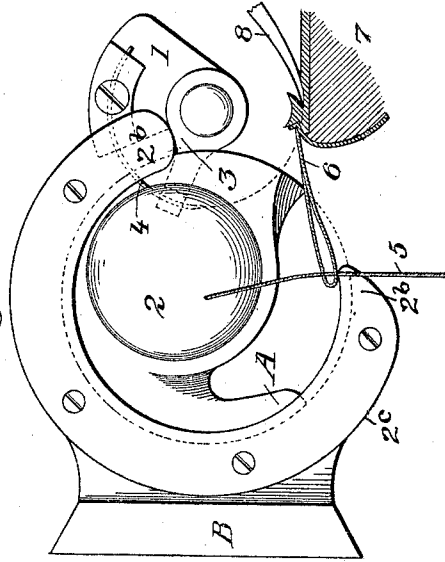
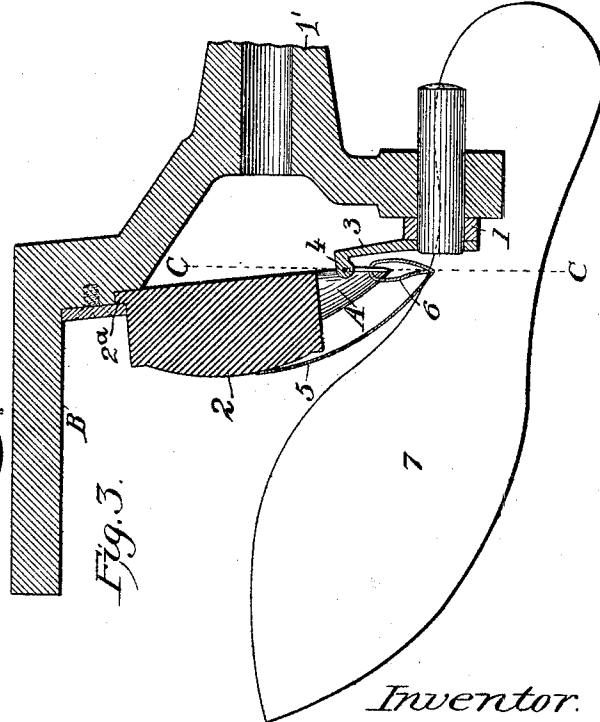

Fig. 1.

Fig. 3.



Witnesses
 John W. Robinson
 George H. Shuttlerff.

Inventor.
 Silas Henry Dyer.

(No Model.)

2 Sheets—Sheet 2.

S. H. DYER.
SEWING MACHINE.

No. 584,543.

Patented June 15, 1897.

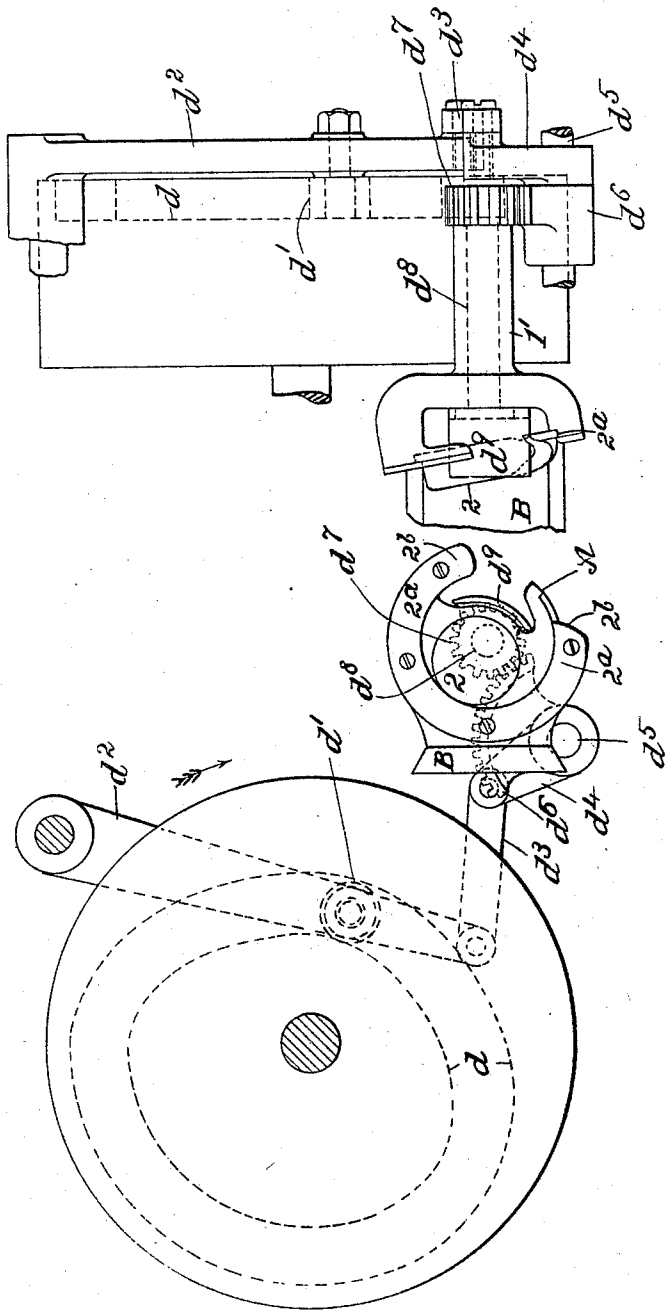

Fig. 6.

Fig. 5.

WITNESSES:

H. P. Guillo
John R. Snow,

INVENTOR

Silas Henry Dyer
BY *J. E. Meynadier.*

ATTORNEY.

UNITED STATES PATENT OFFICE.

SILAS HENRY DYER, OF PAWTUCKET, RHODE ISLAND, ASSIGNOR TO THE CAMPBELL MACHINE COMPANY, OF RHODE ISLAND.

SEWING-MACHINE.

SPECIFICATION forming part of Letters Patent No. 584,543, dated June 15, 1897.

Application filed March 23, 1894. Serial No. 504,867. (No model.)

To all whom it may concern:

Be it known that I, SILAS HENRY DYER, of the city of Pawtucket, in the county of Providence and State of Rhode Island, have invented a new and useful Improvement in Sewing-Machines; and I hereby declare that the following is a full, clear, and exact description of the same, reference being had to the accompanying drawings, forming part of this specification.

The invention relates to the class of sewing-machines known as "lock-stitch wax-thread" sewing-machines, and is especially adapted to welt-sewing machines; and it consists in the peculiar construction and arrangement by which the vamp and welt may be easily stitched to the inner sole of the shoe while on the last however sharp the toe or deeply curved the shank of the last may be, as will be more fully set forth hereinafter.

In welt-sewing machines it is desirable to sew the welt around the sole no matter how deeply curved the shank or how pointed the toe of the last may be. To do this and permit perfect freedom in the movement of the lasted shoe, the stitch-forming part of the machine must project so that the lasted shoe will not come in contact with any other part of the machine so as to obstruct the free operation required. To accomplish this end more fully than has been done in welt-sewing machines is one of the objects of my invention.

Another object of my invention is to simplify the construction and the operation of the stitch-forming part of lock-stitch wax-thread sewing-machines.

My invention consists in an improvement in that type of wax-thread lock-stitch sewing-machines in which the circular path of the point or nose of the shuttle is crosswise of the circular path of the point of the curved hook-needle to enable the point of the shuttle to enter the loop of needle-thread drawn out by the hook-needle, two examples of this class or type being shown in the United States Patent No. 432,011, to J. E. Bertrand, and in the British Patent No. 10,025 of 1892, to Mark Thomas Denne. In both these examples the circular path of the shuttle-point lies in a plane substantially at right angles to the plane which contains the circular path of the nee-

dle-point, and the needle carries a loop of thread directly into the path of the hook or nose of the shuttle, but as soon as the hook has taken the loop the motion of the needle must be reversed to free the loop from the hook of the needle. This compound motion of the needle requires complicated mechanism, which it is the object of my invention to avoid.

In my machine the shuttle and curved hook-needle are arranged in planes so slightly inclined that the continued motion of the shuttle-nose will of itself free the hook of the needle, and, moreover, by this slight inclination of these two planes both shuttle and curved needle are brought practically edgewise to the line of feed, while in all prior machines in which a hook-needle was used the shuttle has been practically flatwise to the line of feed—that is, the shuttle and its race were in a plane substantially parallel with the line of feed instead of substantially crosswise of the line of feed, as in my machine, and this is the distinguishing characteristic of my invention.

I am aware of the British patent to Albrecht, No. 13,352, of 1887, in which a straight hook-needle is combined with a shuttle so that the continued motion of the shuttle frees the loop of thread from the hook of the needle, and I disclaim all that is shown in Albrecht's patent, for Albrecht shows a straight hook-needle and not a curved hook-needle, and his shuttle is substantially parallel to the line of feed instead of crosswise of the line of feed.

In my machine the needle can be made to perform the work of an awl, as well as of the needle, when sewing welts and turned shoes. The hook on the needle can be placed under or on either side of the needle, and in connection with my shuttle and needle I can use a stationary channel-guide.

Figure 1 of the drawings is a side view of so much of my improved welt-sewing machine as is necessary to illustrate my invention. Fig. 2 is a front view of the same. Fig. 3 is a horizontal section through the line X X in Fig. 2. Fig. 4 is also a side view like Fig. 1, with the difference in the relative position of the parts. In Fig. 1 the hook or nose of the shuttle is about to enter the loop drawn out by the needle, while in Fig. 4 the needle is

at its rearward point of oscillation while the shuttle has carried the shuttle-thread through the loop. Figs. 5 and 6 show in front and side elevations means for actuating the shuttle.

5 In the drawings, 2 indicates the shuttle, which is supported in the shuttle-race 2^a. The segmental section between the points 2^b 2^b is left open. On the shuttle a segmental section of the circle in front of the hook or nose is
10 also left open.

A designates the nose of the shuttle; 1, the needle-holder; 3, the needle-guide; 4, the needle; 5, the shuttle-thread; 6, the upper thread; 7, the lasted shoe; 8, a stationary
15 channel-guide.

B designates the part of the frame supporting the needle-holder and the shuttle.

The line C C indicates the edge of the plane which contains the circular path of the point of the curved needle, and the line D D
20 the edge of the plane which contains the circular path of the shuttle-point.

In the construction shown in the drawings (which is the best now known to me) the
25 curved needle 4 is oscillated in the bearing 1' and provided with the needle-guide 3, the oscillation of the needle-holder causing the needle to penetrate the vamp and the proper portion of the sole in order that the needle-
30 thread may be laid in the hook of the needle and so that the needle on its return shall draw a loop of needle-thread, all in the usual way. During this forward and backward
35 motion of the needle the circular path in which its point travels (dotted in Fig. 1) lies in the plane C C, and as the circular path in which the point of the shuttle-nose travels (also dotted in Fig. 1) lies in the plane D D
40 the shuttle is cut away (see Fig. 4) and the motions are so timed that after the needle-point has passed through the path of the point of the shuttle (both paths are indicated in Fig. 1) the point of the nose of the shuttle passes into the loop of the thread 6 (see
45 Figs. 1 and 3) and the continued motion of the shuttle casts the loop off and carries the shuttle-thread 5 through the loop of needle-thread 6. (See Fig. 4.)

I preferably give to the shuttle an oscillat-

ing motion and to the needle an oscillating 50 motion, as those motions can be given by simple means and at high speed, but any construction will embody my invention when the plane C C in which the needle moves is slightly inclined to the plane D D in which 55 the shuttle moves, and both these planes are substantially crosswise of the line of feed.

The means shown for actuating the shuttle consists, essentially, of a cam-groove d in a cam-wheel, Fig. 5, cam-roll d' , connecting- 60 lever d^2 , link d^3 , and lever d^4 on the end of rock-shaft d^5 . Rock-shaft d^5 carries segment d^6 , which meshes with pinion d^7 . Pinion d^7 is fast to shaft d^8 , and the shuttle-driver d^9 is fast to one end of shaft d^8 and engages the 65 shuttle 2, mounted in the shuttle-race 2^a, in the well-known way. The operation is as follows: The rotation of the cam-wheel moves rock-shaft d^5 through connections d^2 d^3 d^4 , giving an oscillating motion to the shaft. 70 Through the segment d^6 and pinion d^7 this motion is transferred to shaft d^8 .

The shuttle-driver d^9 , fast to shaft d^8 , communicates the oscillating motion to the shuttle 2, moving in its race. 75

Having thus described my invention, I claim as new and desire to secure by Letters Patent—

In a lock-stitch sewing-machine the combination of a needle-holder and a curved 80 hook-needle on an axis approximately parallel with the line of feed, so that the plane in which the curved hook-needle moves is crosswise of the line of feed; means to oscillate the curved hook-needle in that plane; a dis- 85 coidal shuttle on an axis approximately parallel with the line of feed but slightly inclined to the axis about which the curved hook-needle moves; a shuttle-race for the shuttle; and means to move the shuttle in its 90 race in a plane crosswise of the line of feed, but slightly inclined to the plane in which the curved hook-needle moves; all substantially as described.

S. HENRY DYER.

Witnesses:

FREDERICK LUECKERT,
ELIZ. M. AULIFF.