

S. R. EARLE.  
COMBINED AIR INJECTOR AND EXHAUSTER.

No. 453,831.

Patented June 9, 1891.

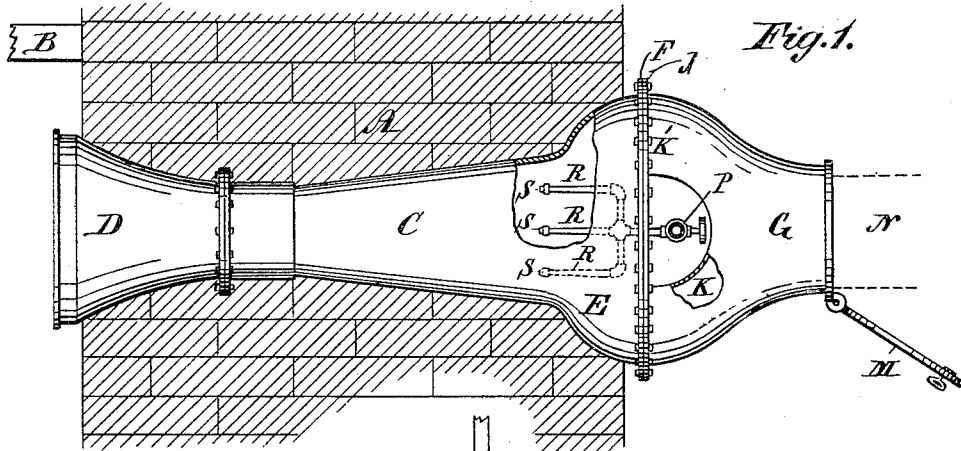

Fig. 1.

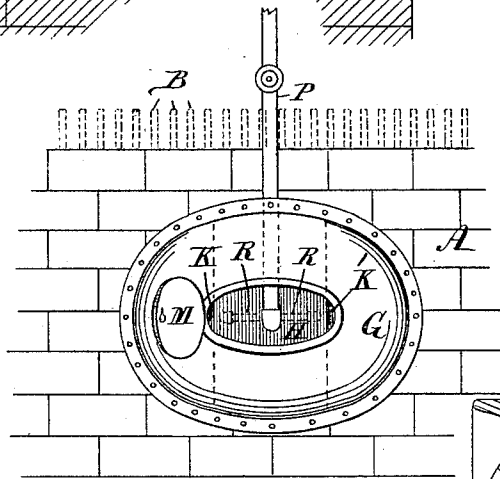

Fig. 2.

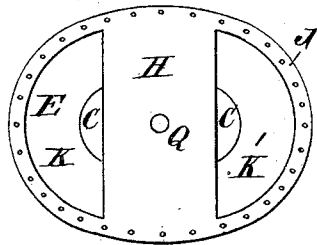

Fig. 3.

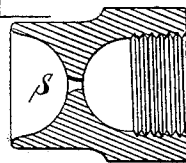

Fig. 4.

Witnesses:  
John Grist  
Chas. H. Storey.

Inventor:  
S. R. Earle  
By Henry Grist  
Attorney.

S. R. EARLE.

COMBINED AIR INJECTOR AND EXHAUSTER.

No. 453,831.

Patented June 9, 1891.

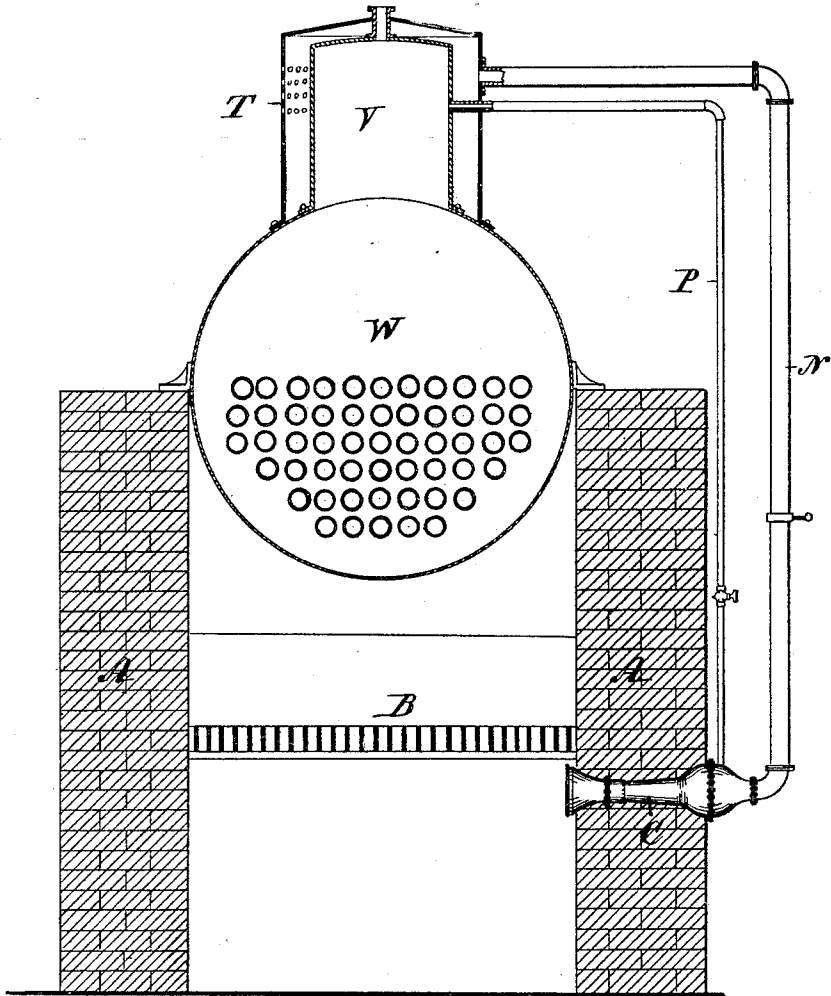

Fig. 5.

Witnesses:  
John Crist  
Attorney

Inventor:  
S. R. Earle  
By Henry Crist  
Attorney

# UNITED STATES PATENT OFFICE.

SALYER REED EARLE, OF BELLEVILLE, CANADA.

## COMBINED AIR INJECTOR AND EXHAUSTER.

SPECIFICATION forming part of Letters Patent No. 453,831, dated June 9, 1891.

Application filed March 23, 1891. Serial No. 386,082. (No model.) Patented in Canada February 2, 1891, No. 35,929.

*To all whom it may concern:*

Be it known that I, SALYER REED EARLE, of the city of Belleville, in the Province of Ontario, in the Dominion of Canada, have invented certain new and useful Improvements in a Combined Air Injector and Exhauster, (for which I have obtained a patent of Canada, No. 35,929, dated February 2, 1891;) and I do hereby declare that the following is a full, clear, and exact description of the same, reference being had to the accompanying drawings, in which—

Figure 1 is a top view of my combined injector and exhauster, a portion of the suction-inlet broken away to show the dividing-wall. Fig. 2 is an end view of the same. Fig. 3 is an elevation of that end of the suction connection which is attached to the injector-tube. Fig. 4 is a section of one of the steam-nozzles enlarged, and Fig. 5 is a sectional elevation of a furnace and boiler, showing my injector and exhauster applied to the furnace and connecting with the steam-dome of the boiler to obtain hot air and steam.

My invention has for its object to make an air and steam injector noiseless in operation and to adapt it for ventilating mines, sewers, ships' holds, and a variety of other purposes.

My invention consists in certain features of construction and combination of parts, which are hereinafter described, and indicated in the claims.

A represents the wall of a furnace, and B the grate-bars.

C is a tapering tube inserted through the wall, the smaller end provided with a flaring outlet or discharge D and the larger end of said tube provided with a circumferential swell E for the enlargement of said end, and said enlargement or swell has a peripheral flange F, to which is bolted a Y-shaped tubular connection G, forming a divided inlet, the space between the branches filled with a bridge-plate H. The ends of said bridge-plate and the exterior semi-circumference of said branches have a flange J, corresponding to the flange F of the tube C, and said flanges are bolted together, thereby dividing the in-

let into two sections K K' at the larger end of the tube C.

The suction-connection G is provided with a damper-valve or door M to close said inlet when a supply of air to the furnace under a slow combustion is not desired, and to said inlet may be connected a hose or pipe N (shown in dotted lines in Fig. 1) leading into a mine, sewer, ship's hold, building, &c., to induce a ventilating-current therein.

P is a steam-pipe entering the tube C through a hole Q in the bridge-plate H, and said pipe is provided with branches R, each having a steam-nozzle S for injecting steam into the tube C, whereby suction of air into the tube will be created through the Y-shaped tubular connection G and forced out of the tube to supply a furnace, and for exhaustion of air from a mine, sewer, &c., through the connecting-pipe N when used for such purposes.

The application of my air injector and exhauster as applied to a furnace and steam-boiler is shown in Fig. 5, wherein the air-pipe N is connected to a perforated jacket T, inclosing the dome V of a steam-boiler W for supply of hot air, and the steam-pipe P is connected to the dome for supply of steam to feed the furnace with commingled air and steam to assist combustion.

I claim as my invention—

1. The tapering tube C, having a flaring mouth at the smaller end and a swell or enlargement F at the larger end, said enlargement peripherally closed by a corresponding Y-shaped tubular connection G, as set forth.

2. The combination, with the tapering tube C, having a flaring outlet at the smaller end and a swell or enlargement E at the larger end, of a Y-shaped tubular connection G, bolted to said enlargement peripherally, and a steam-pipe entering the tube C between the branches of said connection, said pipe having a series of branches R, each provided with a nozzle S, as set forth.

SALYER REED EARLE.

Witnesses:

J. A. PHILLIPS.

E. ORMANDY.