



(12) **EUROPEAN PATENT APPLICATION**

(43) Date of publication:  
17.01.2001 Bulletin 2001/03

(51) Int. Cl.<sup>7</sup>: **B41F 15/22**

(21) Application number: **00112878.4**

(22) Date of filing: **19.06.2000**

(84) Designated Contracting States:  
**AT BE CH CY DE DK ES FI FR GB GR IE IT LI LU  
MC NL PT SE**  
Designated Extension States:  
**AL LT LV MK RO SI**

(72) Inventor: **LOSI, Bruno**  
**I-53034 Colle Val D'Elsa SI (IT)**

(74) Representative: **Celestino, Marco**  
**ABM, Agenzia Brevetti & Marchi,**  
**Via A. Della Spina 40**  
**56125 Pisa (IT)**

(30) Priority: **18.06.1999 IT PI990037**

(71) Applicant: **LOSI, Bruno**  
**I-53034 Colle Val D'Elsa SI (IT)**

(54) **Silk-screen printing method and printing machine that carries out this method**

(57) A silk-screen printing machine (1) comprising a base frame (2) with respect to which a flat support (3) for a sheet (4) can move from a loading position (5) to a printing position (6) under a silk-screen (7), having a silk screen (7'), relatively to which a support (8) can slide comprising a doctor (9) and a counter-doctor (10). Above the printing zone (6) a shield (11) is provided suitable for protecting the operator from the vapour of ink present on the silk cloth (7). The base frame (2), at the loading zone (5), has positioning registers of reference (12,13) suitable for allowing the location of the sheet (4) with respect to the flat support (3), so that when the latter is located in the printing zone (6) the sheet (4) is positioned correctly with respect to the silk-

screen (7). The flat support (3) is of vacuum type and has a projecting grid (20) on which the sheet (4') already printed in a previous step can rest. The machine provides furthermore two pawls (21,22) that engage with the flat support (3) and the grid (20). Opposite to the loading zone (5) an unloading zone (14) is provided where a conveyor belt (23) is present. At the end of the printing step, the back stroke of the flat support (3) towards the loading position (5) is effected, and the pawls (21, 22) block the back stroke of the sheet just printed (4) and the sheet previously printed (4'), which fall respectively on the grid (20) and on an unloading zone (14).

**Fig. 1**

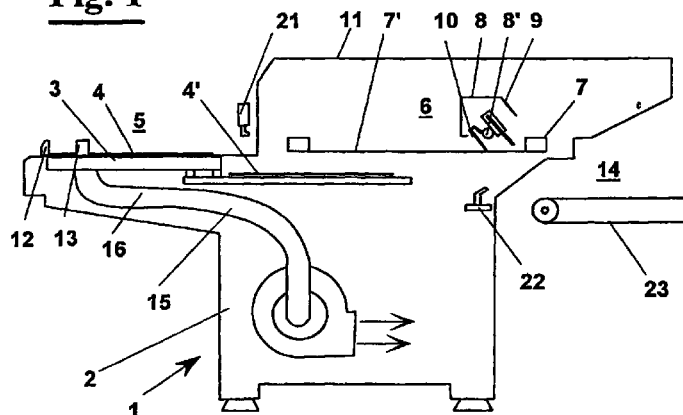

**Description**Field of the invention

**[0001]** The present invention relates to the field of graphic printing machines, and more precisely it relates to a silk-screen printing method with automatic delivery of the sheets.

**[0002]** Furthermore the invention relates to a silk-screen printing machine that carries out this method.

Description of the prior art

**[0003]** Traditional manual silk-screen printing machines provide a fixed flat support for a sheet to print. Usually the flat support is a suction plane for making easier the adhesion of the sheet. Above the flat support a movable support is provided holding a silk-screen for an ink of predetermined colour and an ink spreading means, commonly said doctor and counter-doctor.

**[0004]** The movable support of the silk-screen can be closed normally book-like on the flat support about a pivot axis opposite to the operator. For a correct arrangement of the sheet on the flat support positioning registers are necessary, so that the printing is effected with precision in a predetermined zone of the sheet. The precision of reference points for the sheets is essential in the silk-screen printing with several colours.

**[0005]** Practically, every sheet to print is arranged on the support plane, and, in the machines with suction plane, the operator commands the vacuum with a pedal. Then, manually, the operator lowers the support so that the silk-screen contacts the sheet. Automatically, or manually, the doctor effects a stroke for spreading the ink over the silk-screen and applying a layer of colour onto the sheet. In this step most of silk screen printing machines provide the silk-screen with a slight inclination towards the above after the passage of the doctor in order to avoid smudges of colour on the sheet.

**[0006]** At the end of the stroke, the counter-doctor with a backward movement removes the ink from the silk-screen gathering the ink all on a side and then the operator raises again the movable support, picking up the printed sheet from the flat support and putting it in a drier.

**[0007]** Manual machines of the above kind have the following drawbacks:

- the operator must carry out manually the two steps of loading and unloading the sheets;
- being the positioning registers thin in order not to disturb the printing step, the loading step must be effected with care to avoid that the sheet are placed incorrectly. In this case the thinner is the sheet to print the more is the loading difficult; in fact the thinner the positioning registers are, the more their correct placement is troublesome;
- the duration of the cycle is high owing to the double

loading stepping and unloading and to the need of raising and lowering manually the movable support;

- automatic sheet removing systems exist, for example by means of suction elements, which however have the drawback of being bulky and of requiring high additional costs, and in any case in the step of removal of the sheet from the flat support there is the risk of damaging the printing still fresh;
- la need of lowering and raising every time the support of the silk-screen prevents from using effective suction systems of the ink vapour, since every time the movable support is raised the printing zone is open.

**[0008]** Machines also exist wherein the support plane slides horizontally. However, except from the advantage of not raising and lowering the movable support, the same problems arise of unloading manually the sheets or of using expensive devices for picking up the sheets.

**[0009]** Concerning the silk-screen printing step, there is the drawback that in traditional machines the counter-doctor is at an angle with respect to the silk-screen and during the approach to the silk screen the counter-doctor wears the silk-screen in the point of impact.

Summary of the invention

**[0010]** It is object of the present invention to provide a silk-screen printing method wherein the step of unloading the printed sheets is carried out in an easy and automatic way, without the need of expensive auxiliary apparatus.

**[0011]** It is still object of the present invention to provide a silk-screen printing method wherein the doctor and the counter-doctor has a smooth stroke that does not cause wear of the silk-screen.

**[0012]** It is another object of the present invention to provide a silk-screen printing machine that carries out this method.

**[0013]** These and other objects are achieved by the silk-screen printing method according to the invention, which can be fixed to a silk-screen printing machine comprising a flat support for a sheet or other article to print, a silk-screen and means for effecting an ink spreading on the silk screen, comprising the steps of:

- loading a sheet to print flat support;
- translating the flat support from a loading position to a printing position of the sheet under the silk screen;
- lowering the silk-screen and effecting an ink spreading on the sheet;
- arranging a first pawl between the printing position and the loading position;
- back stroke of the flat support towards the loading position, the pawl at the passage of the flat support

blocking the back stroke of the sheet, whereby the sheet falls in a zone located under the silk screen.

**[0014]** In particular, at the moment of the fall of the sheet in the zone located under the silk-screen the further steps can be provided of:

- keeping the sheet on a suspension grid,
- loading a second sheet and forward stroke of the flat support again in the printing position, the sheet on the suspension grid running from a position located under the silk-screen to an unloading position on the grid;
- arranging a second pawl between the position located under the silk-screen and the unloading position,
- back stroke of the flat support in the loading position and of the grid in a position located under the silk screen, a second pawl at the passage of the grid blocking the sheet that is being carried by the grid, whereby the sheet falls in a an unloading zone.

**[0015]** In the zone of fall under the silk-screen or in the unloading zone a step is provided of delivering the sheet on a mezzo of transfer, for example a conveyor belt.

**[0016]** Preferably, the ink spreading on the silk-screen is executed by means of a doctor and a counter-doctor integral to a support, a step of rotation being provided of the doctor and the counter-doctor between a first position, wherein the doctor contacts the silk-screen and the counter-doctor is raised with respect to the silk screen, and a second position, wherein the doctor is raised with respect to the silk-screen and the counter-doctor contacts the silk screen, whereby the contact of the doctor and the counter-doctor with the silk-screen is carried out according to a curved line arranged substantially tangential with respect to the silk screen.

**[0017]** According to another aspect of the invention, a machine for silk-screen printing, having a flat support for a sheet or other article to print, a silk-screen and means for effecting a ink spreading on the silk screen, comprises:

- means for translating the flat support from a loading position, wherein a sheet to print is arranged thereon, to a printing position under the silk screen;
- means for lowering the silk-screen and for spreading ink;
- a first pawl located between the printing position and the loading position and movable from a rest position to a position of intersection with the sheet trajectory;
- a zone located under the silk-screen suitable for receiving the sheet in case of interference of the sheet with the first pawl during the back stroke of the flat support towards the loading position.

**[0018]** The zone located under the silk-screen suitable for receiving the sheet advantageously comprises a suspension grid that extends from the flat support opposite to the loading zone, the grid being movable from a position located under the silk-screen to an unloading position. A second pawl is provided between the position located under the silk-screen and the unloading position, movable between a position of intersection with the sheet trajectory and a rest position, whereby during the back stroke of the grid towards the position located under the silk screen, the second pawl is moved to a position of interference and blocks the sheet, which falls in a an unloading zone.

**[0019]** In the zone of fall under the silk-screen or in the unloading zone means of transfer of the sheet can be provided.

**[0020]** Advantageously, the means for effecting an ink spreading comprise a doctor and a counter-doctor integral to a support, means being provided on the support for rotating the doctor and the counter-doctor with respect to a longitudinal axis between a first position, wherein the doctor contacts the silk-screen and the counter-doctor is raised with respect to the silk screen, and a second position, wherein the doctor is raised with respect to the silk-screen and the counter-doctor contacts the silk screen, whereby the contact of the doctor and the counter-doctor with the silk-screen is carried out according to a curved line.

**[0021]** In a preferred embodiment the means for translating move the flat support from the loading position to the printing position on a base frame, in the loading position the base frame comprising fixed means of reference for positioning the sheet on the flat support ready for the following printing step, the means of reference being fastened to the edges of the flat support when it is in the loading position. The sheet is positioned in the loading position along two adjacent edges of the flat support, the silk-screen in the printing position having two adjacent edges located above said two edges of the flat support.

#### Brief description of the drawings

**[0022]** Further characteristics and the advantages of the machine and of the method for silk-screen printing according to the present invention will be made clearer with the following description of an embodiment thereof, exemplifying but not limitative, with reference to attached drawings wherein:

- figure 1 shows a sectional view Of a machine for silk-screen printing that uses the method according to the invention in a first working position and precisely a loading position;
- figure 2 shows the machine of figure 1 in a second working position, during the printing step;
- figure 3 shows the machine of figure 1 in a first step of back stroke of the flat support after the printing;

- figure 4 shows the machine of figure 1 in a successive steps of back stroke of the support plane.

#### Description of an the preferred embodiments

**[0023]** With reference to figure 1, a silk-screen printing machine 1 according to the invention comprises a base frame 2 with respect to which a flat support 3 for a sheet 4 can be moved by not shown means from a loading position 5 to a printing position 6 (figure 2).

**[0024]** In the printing position 6 the flat support 3 is located under a silk-screen 7, having a silk cloth 7', relatively to which a support 8 can slide comprising a doctor 9 and a counter-doctor 10.

**[0025]** Above the printing zone 6 a shield 11 is provided for protecting the operator from the vapour of ink present on the silk cloth 7. The base frame 2, at the loading zone 5, has positioning registers 12 and 13 suitable for allowing the correct delivery of the sheet 4 on the flat support 3, so that, when the latter is located (figure 2) in the printing zone 6, the sheet 4 is positioned correctly with respect to the silk-screen 7.

**[0026]** The flat support 3 is of vacuum type, i.e. it is perforated and under it a suction chamber is provided wherein vacuum is made by means of a suction pump 15 and a flexible tube 16.

**[0027]** The suction plane 3 has a grid 20 projecting outwardly on which a sheet 4' can rest that has been already printed in a previous step. The machine provides furthermore two pawls 21 and 22 suitable for engaging with the flat support 3 of the grid 20 in the way hereinafter described. Opposite to the loading zone 5 a an unloading zone 14 is provided where a conveyor belt 23 is present, for example of transfer into a drier.

**[0028]** The operative steps of the machine are the following:

- loading the sheet 4 to print on the flat support 3 in the loading position 5 (figure 1);
- translating the flat support 3 from the loading position 5 of figure 1 (indicated with a dotted line in figure 2) to the printing position 6 of the sheet 4 under the silk-screen 7 (figure 2),
- lowering the silk-screen 7 and effecting an ink spreading stroke on the sheet 4 by means of doctor 9, running from the position indicated with a continuous line of figure 2 to the position indicated with a dotted line;
- arranging the first pawl 21 between the printing position 6 and the loading position 5, so that it intersects the trajectory of printed sheet 4, but it does not block the flat support 3;
- back stroke (figure 3) of the flat support 3 towards the loading position 5, whereby the pawl 21 at the passage of the flat support 3 blocks the back movement of the sheet 4, which slides on the flat support 3 and falls below the printing zone 6 under the silk-screen 7 (figure 4).

**[0029]** At the moment of the fall the sheet 4 is held by grid 20, which protrudes from the flat support 3.

**[0030]** The sheet 4', which had been previously held by the suspension grid 20, as shown in figures 3 and 4, at the moment of the back stroke of the flat support 3 and of the grid 20 is blocked by second pawl 22, which in the meantime has been raised (figure 2). Therefore, sheet 4', as shown in figure 4, slides on the grid 20 and falls on conveyor belt 23 located in the unloading zone 14.

**[0031]** Concerning the loading step, sheet 4 position can be effected very easily by means of the positioning registers 12 and 13, which are fixed to the base frame 2 and then do not disturb the printing zone 6 and the silk-screen 7. Positioning registers 12 and 13 are arranged so that they coincide with the position of stop of the flat support 3 in the loading zone 5.

**[0032]** Concerning the step of printing, as shown in figure 2, the movement of the support 8 that causes the spreading of the ink on the silk-screen 7 is carried out when support 8 is rotated with respect to a pin 8', so that the doctor 9 touches the silk cloth 7' of silk-screen 7. At the end of the printing step, as shown in figure 3, the support 8 rotates about pin 8' so that counter-doctor 10 contacts smoothly silk cloth 7' of silk-screen 7 and then, as shown in figure 4, effects the movement of gathering the ink present on the silk cloth 7' same.

**[0033]** The machine for silk-screen printing that carries out the method according to the invention has then the following advantages:

- it operates in a way easy and automatic;
- it allows the evacuation of the printed sheets without richiedere expensive apparecchiature;
- the stroke of the doctor and of the counter-doctor is carried out in a smooth way and it does not cause quick wear of the silk-screen;
- the positioning step is easy and makes quick the steps of preparation of the printing on the machine;
- the cycle time is substantially half than the prior art since the step of manual unloading and the need of raising and lowering manually the movable support are avoided;
- the presence of a shield cover that has not to be raised and lowered every time allows the use of effective suction systems of the ink vapour;
- the movement of the flat support from the loading zone to the printing zone can be effected between two positions of fixed stroke end without the need of systems of detection of the position.

**[0034]** The foregoing description of a specific embodiment will so fully reveal the invention according to the conceptual point of view, so that others, by applying current knowledge, will be able to modify and/or adapt for various applications such an embodiment without further research and without parting from the invention, and it is therefore to be understood that such

adaptations and modifications will have to be considered as equivalent to the specific embodiment. The means and the materials to realise the different functions described herein could have a different nature without, for this reason, departing from the field of the invention. It is to be understood that the phraseology or terminology employed herein is for the purpose of description and not of limitation.

## Claims

1. A silk-screen printing method, which can be carried out by a silk-screen printing machine comprising a flat support for a sheet or other article to print, a silk-screen and means for effecting an ink spreading on said silk screen, characterised in that it comprises the steps of:
  - loading a sheet to print on said flat support;
  - translating said flat support from a loading position to a printing position of said sheet under said silk screen;
  - lowering said silk-screen and effecting an ink spreading through said screen on said sheet;
  - arranging a first pawl between said printing position and said loading position;
  - effecting a back stroke of said flat support towards said loading position, said pawl at the passage of said flat support blocking a back movement of said sheet, whereby said sheet falls in a zone located under said silk screen.
2. Method according to claim 1 wherein at the moment of the fall of said sheet in said zone located under said silk-screen the further steps are provided of:
  - keeping said sheet on a suspension grid,
  - loading a second sheet and forward stroke of said flat support again in said printing position, said sheet on said suspension grid running from a position located under said silk-screen to an unloading position on said grid;
  - arranging a second pawl between said position located under said silk-screen and said unloading position,
  - effecting a further back stroke of said flat support to said loading position and of said grid to said position located under said silk screen, said second pawl at the passage of said grid blocking a back movement of said sheet on said grid, whereby said sheet falls in a an unloading zone.
3. Method according to claims 1 or 2 wherein in said zone of fall under said silk-screen or in said unloading zone is provided a step of transfer said sheet on a conveyor means.
4. Method according to claim 1, wherein said ink spreading step on said silk-screen is carried out by means of a doctor and a counter-doctor integral to a support, a step of rotation being provided of said doctor and said counter-doctor between a first position, wherein said doctor contacts said silk-screen and said counter-doctor is raised with respect to said silk screen, and a second position, wherein said doctor is raised with respect to said silk-screen and said counter-doctor contacts said silk screen, whereby the contact between said doctor and said counter-doctor with said silk-screen is carried out according to a curved line arranged substantially tangential with respect to said silk screen.
5. Machine for silk-screen printing, comprising a flat support for a sheet or other article to print, a silk-screen and means for effecting an ink spreading on said silk screen, characterised in that it comprises:
  - means for translating said flat support from a loading position, wherein a sheet to print is arranged thereon, to a printing position under said silk screen;
  - means for lowering said silk-screen and for spreading ink;
  - a first pawl located between said printing position and said loading position and movable from a rest position to a position of interference with said sheet,
  - a zone located under said silk-screen suitable for receiving said sheet in case of interference of said sheet with said first pawl during the back stroke of said flat support towards said loading position.
6. Machine according to claim 5, wherein said zone located under said silk-screen suitable for receiving said sheet comprises a suspension grid that extends from said flat support opposite to said loading zone, said grid being movable from a position located under said silk-screen to an unloading position, a second pawl being provided between said position located under said silk-screen and said unloading position, movable between a position of interference with said sheet and a rest position, whereby during the back stroke of said grid towards said position located under said silk screen, said second pawl is in said position of interference and blocks said sheet, which falls in a an unloading zone.
7. Machine according to claim 5, wherein in said zone of fall under said silk-screen or in said unloading zone means of transfer of said sheet are provided.
8. Machine according to claim 5, wherein said means for effecting an ink spreading comprises a doctor

and a counter-doctor integral to a movable support, means being provided on said movable support for rotation of said doctor and said counter-doctor with respect to a longitudinal axis between a first position, wherein said doctor contacts said silk-screen 5 and said counter-doctor is raised with respect to said silk screen, and a second position, wherein said doctor is raised with respect to said silk-screen and said counter-doctor contacts said silk screen, wherein the contact between said doctor and said 10 counter-doctor with said silk-screen is carried out according to a curved line.

9. Machine according to claim 5, wherein said means for translating move said flat support from said loading position to said printing position on a base frame, in said loading position said base frame comprising fixed means of reference for positioning said sheet on said flat support ready for the following printing step, said means of reference being fastened to the edges of said flat support when it is in said loading position. 15 20

10. Machine according to claim 5, wherein said sheet is positioned in said loading position along two adjacent edges of said flat support, said silk-screen in said printing position having two adjacent edges located above said two edges of said flat support. 25 30

30

35

40

45

50

55

**Fig. 1**

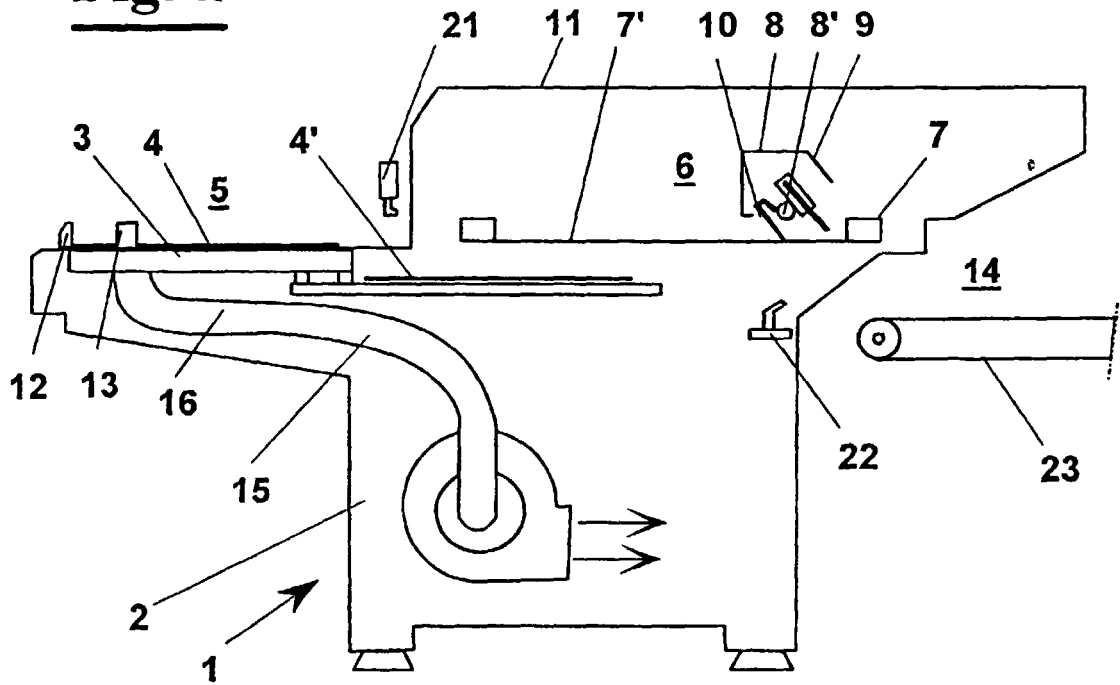

**Fig. 2**

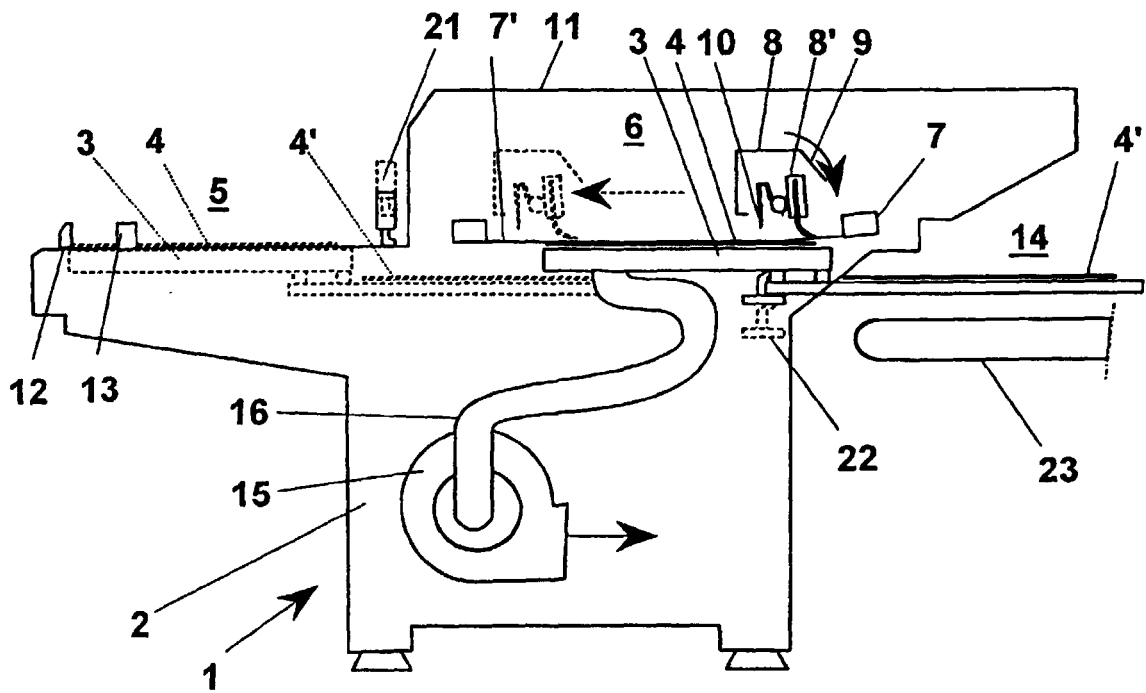

**Fig. 3**

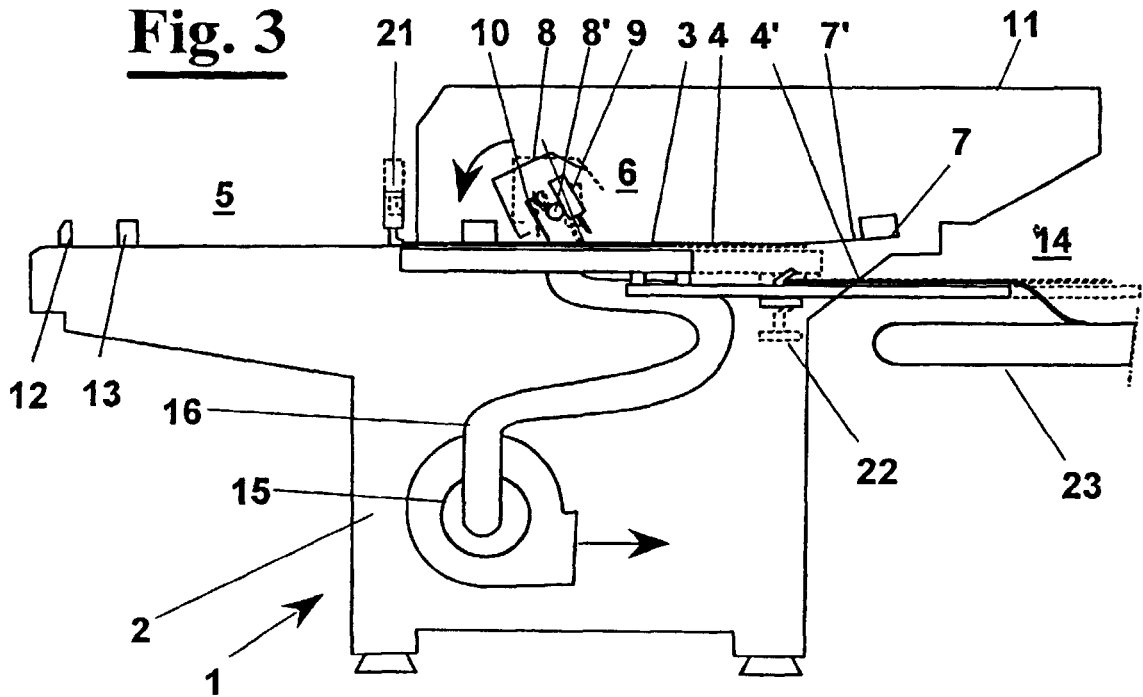

**Fig. 4**

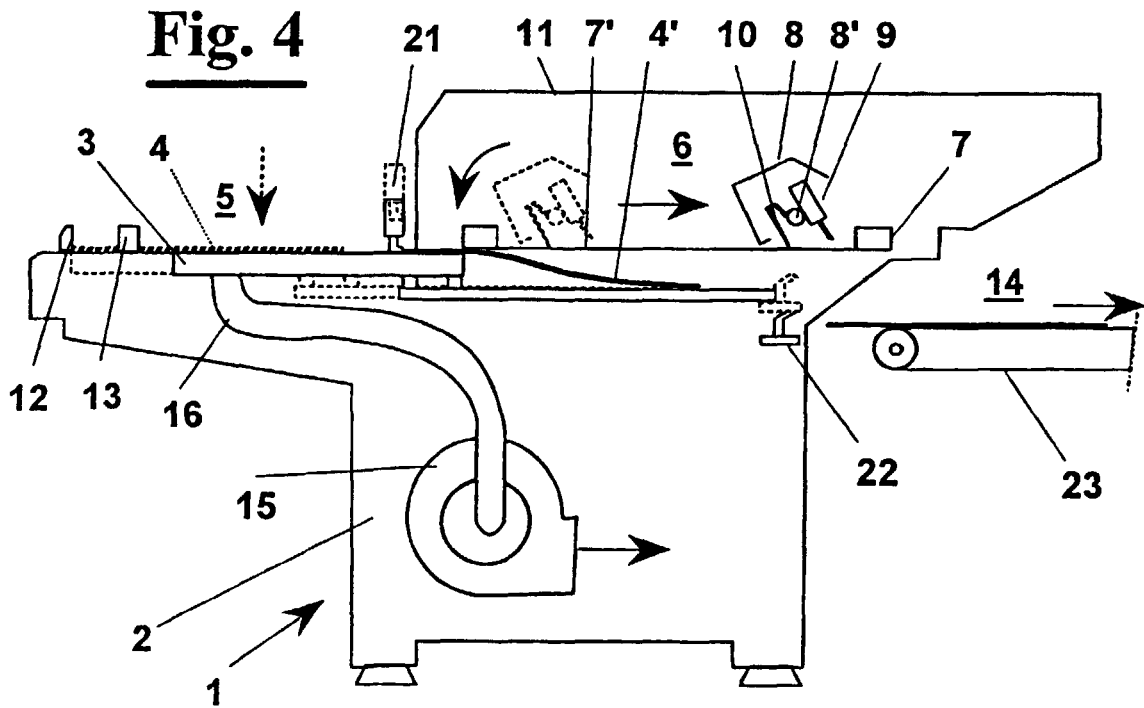



European Patent  
Office

EUROPEAN SEARCH REPORT

Application Number  
EP 00 11 2878

DOCUMENTS CONSIDERED TO BE RELEVANT			
Category	Citation of document with indication, where appropriate, of relevant passages	Relevant to claim	CLASSIFICATION OF THE APPLICATION (Int.Cl.7)
X	US 4 210 077 A (LINDSTROM NILS A E) 1 July 1980 (1980-07-01) * the whole document *	1,5	B41F15/22
A	EP 0 453 988 A (SPS SIEBDRUCKMASCHINEN GMBH) 30 October 1991 (1991-10-30) * the whole document *	1,5	
A	EP 0 173 064 A (SVANTESSON AKE) 5 March 1986 (1986-03-05) * claim 1; figures 1,2 *	1,5	
A	US 4 254 707 A (LAMBERT ET AL) 10 March 1981 (1981-03-10) * column 4, line 41 - line 68; figure 1 *	4,8	
The present search report has been drawn up for all claims			TECHNICAL FIELDS SEARCHED (Int.Cl.7)
			B41F
Place of search	Date of completion of the search	Examiner	
THE HAGUE	20 October 2000	DIAZ-MAROTO, V	
CATEGORY OF CITED DOCUMENTS		T : theory or principle underlying the invention	
X : particularly relevant if taken alone		E : earlier patent document, but published on, or after the filing date	
Y : particularly relevant if combined with another document of the same category		D : document cited in the application	
A : technological background		L : document cited for other reasons	
O : non-written disclosure		& : member of the same patent family, corresponding document	
P : intermediate document			

EPO FORM 1503 03.82 (P4/C01)

**ANNEX TO THE EUROPEAN SEARCH REPORT  
ON EUROPEAN PATENT APPLICATION NO.**

EP 00 11 2878

This annex lists the patent family members relating to the patent documents cited in the above-mentioned European search report. The members are as contained in the European Patent Office EDP file on  
The European Patent Office is in no way liable for these particulars which are merely given for the purpose of information.

20-10-2000

Patent document cited in search report	Publication date	Patent family member(s)	Publication date
US 4210077 A	01-07-1980	NONE	
EP 0453988 A	30-10-1991	DE 9004738 U	29-08-1991
EP 0173064 A	05-03-1986	SE 456640 B	24-10-1988
		AT 37824 T	15-10-1988
		AT 36273 T	15-08-1988
		AT 24152 T	15-12-1986
		AT 57135 T	15-10-1990
		AU 568486 B	07-01-1988
		AU 1057583 A	28-07-1983
		BR 8300233 A	18-10-1983
		CA 1197138 A	26-11-1985
		DE 3368228 D	22-01-1987
		DE 3377629 T	15-09-1988
		DE 3378199 D	17-11-1988
		DE 3378199 T	17-11-1988
		DE 3381928 D	08-11-1990
		EP 0109597 A	30-05-1984
		EP 0109598 A	30-05-1984
		EP 0109599 A	30-05-1984
		EP 0085034 A	03-08-1983
		ES 519035 D	01-06-1984
		ES 8404780 A	16-08-1984
		JP 1826414 C	28-02-1994
		JP 5030622 B	10-05-1993
		JP 59001258 A	06-01-1984
		SE 8200276 A	20-07-1983
		SE 454338 B	25-04-1988
		SE 8306374 A	18-11-1983
		SE 454339 B	25-04-1988
		SE 8306375 A	18-11-1983
		SE 457338 B	19-12-1988
		SE 8306376 A	18-11-1983
		US 4589335 A	20-05-1986
		US 4848226 A	18-07-1989
		ZA 8300165 A	26-10-1983
US 4254707 A	10-03-1981	NONE	

EPO FORM P0459

For more details about this annex : see Official Journal of the European Patent Office, No. 12/82