



(51) International Patent Classification:

A47K 1/00 (2006.01) A47K 11/02 (2006.01)  
A47K 3/00 (2006.01) C03C 17/36 (2006.01)

(21) International Application Number:

PCT/US2018/066524

(22) International Filing Date:

19 December 2018 (19.12.2018)

(25) Filing Language:

English

(26) Publication Language:

English

(30) Priority Data:

15/849,879 21 December 2017 (21.12.2017) US

(71) Applicant: **GUARDIAN GLASS, LLC** [US/US]; 2300 Harmon Road, Auburn Hills, MI 48326-1714 (US).

(72) Inventors: **KRASNOV, Alexey**; 2013 Woodmont Court, Canton, MI 48188 (US). **DEN BOER, Willem**; 9184 Lanning Lane, Brighton, MI 48116 (US). **BLUSH, Jason**; 4717 Hawkview Court, Milford, MI 48380 (US). **AKKASHIAN, Eric, W.**; 4793 Motorway, Waterford, MI 48328 (US).

(74) Agent: **RHOA, Joseph, A.**; Nixon & Vanderhye P.C., 901 North Glebe Road, 11th Floor, Arlington, VA 22203-1808 (US).

(81) Designated States (unless otherwise indicated, for every kind of national protection available): AE, AG, AL, AM, AO, AT, AU, AZ, BA, BB, BG, BH, BN, BR, BW, BY, BZ, CA, CH, CL, CN, CO, CR, CU, CZ, DE, DJ, DK, DM, DO, DZ, EC, EE, EG, ES, FI, GB, GD, GE, GH, GM, GT, HN, HR, HU, ID, IL, IN, IR, IS, JO, JP, KE, KG, KH, KN, KP, KR, KW, KZ, LA, LC, LK, LR, LS, LU, LY, MA, MD, ME, MG, MK, MN, MW, MX, MY, MZ, NA, NG, NI, NO, NZ, OM, PA, PE, PG, PH, PL, PT, QA, RO, RS, RU, RW, SA, SC, SD, SE, SG, SK, SL, SM, ST, SV, SY, TH, TJ, TM, TN, TR, TT, TZ, UA, UG, US, UZ, VC, VN, ZA, ZM, ZW.

(84) Designated States (unless otherwise indicated, for every kind of regional protection available): ARIPO (BW, GH, GM, KE, LR, LS, MW, MZ, NA, RW, SD, SL, ST, SZ, TZ, UG, ZM, ZW), Eurasian (AM, AZ, BY, KG, KZ, RU, TJ, TM), European (AL, AT, BE, BG, CH, CY, CZ, DE, DK, EE, ES, FI, FR, GB, GR, HR, HU, IE, IS, IT, LT, LU, LV, MC, MK, MT, NL, NO, PL, PT, RO, RS, SE, SI, SK, SM, TR), OAPI (BF, BJ, CF, CG, CI, CM, GA, GN, GQ, GW, KM, ML, MR, NE, SN, TD, TG).

(54) Title: TRANSPARENT CONDUCTIVE COATING FOR CAPACITIVE TOUCH PANEL WITH SILVER HAVING ADJUSTED RESISTANCE

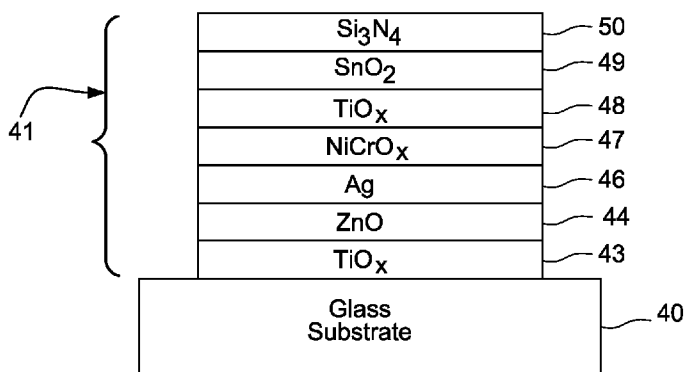


FIG. 4(a)

(57) Abstract: A multi-layer conductive coating is substantially transparent to visible light, contains at least one conductive layer comprising silver that is sandwiched between at least a pair of dielectric layers, and may be used as an electrode and/or conductive trace in a capacitive touch panel. The multi-layer conductive coating may contain a dielectric layer(s), and may be used in applications such as capacitive touch panels for controlling showers, appliances, vending machines, electronics, electronic devices, and/or the like. In certain example embodiments, different electrodes of the touch panel may have different resistance, with the respective silver-based structures of various electrodes being different from one another to provide different resistance for different electrodes.



**Published:**

— *with international search report (Art. 21(3))*

TRANSPARENT CONDUCTIVE COATING FOR CAPACITIVE TOUCH PANEL  
WITH SILVER HAVING ADJUSTED RESISTANCE

**[0001]** This application is a continuation-in-part (CIP) of U.S. Serial No. 15/678,266, filed August 16, 2017, which is a continuation-in-part (CIP) of U.S. Serial No. 15/647,541 filed July 12, 2017, which is a continuation of U.S. Serial No. 15/215,908 filed July 21, 2016 (U.S. Patent No. 9,733,779), which is a continuation-in-part (CIP) of U.S. Serial No. 15/146,270 filed May 4, 2016, which is a continuation of U.S. Serial No. 13/685,871 filed November 27, 2012 (now U.S. Patent No. 9,354,755), the disclosures of which are all hereby incorporated herein by reference in their entireties. This application is also a continuation-in-part (CIP) of U.S. Serial No. 15/678,266, filed August 16, 2017, which is a continuation-in-part (CIP) of U.S. Serial No. 15/409,658 filed January 19, 2017, which is a continuation of U.S. Serial No. 14/681,266 filed April 8, 2015 (now U.S. Patent No. 9,557,871), the disclosures of which are all hereby incorporated herein by reference in their entireties.

**[0002]** Example embodiments of this invention relate to a multi-layer conductive coating that is substantially transparent to visible light, contains at least one conductive layer comprising silver that is sandwiched between at least a pair of dielectric layers, and may be used as an electrode and/or conductive trace in a capacitive touch panel. The multi-layer conductive coating may contain a layer of or including zirconium oxide (e.g.,  $ZrO_2$ ) and/or silicon nitride in certain embodiments, and may be used in applications such as capacitive touch panels for controlling showers, appliances, vending machines, electronics, electronic devices, and/or the like. In certain example embodiments, the coating includes a silver layer(s) and may be used as an electrode(s) in a capacitive touch

panel so as to provide for an electrode(s) transparent to visible light but without much visibility due to the more closely matching visible reflection of the coating on the substrate to that of an underlying substrate in areas where the coating is not present. The coating also has improved conductivity (e.g., smaller sheet resistance  $R_s$  or smaller emissivity, given a similar thickness and/or cost of deposition) compared to typical ITO coatings used in touch panels. In certain example embodiments, the coating for at least one electrode may have increased resistance, and thus reduced conductivity, compared to pure silver layers of certain coatings, in order to allow the silver-based coating to be more suitable for use as touch panel electrodes. In certain example embodiments, different electrodes of the touch panel may have different resistance, with the respective silver-based structures of various electrodes being different from one another to provide different resistivities/resistances for different electrodes. For example, transmit electrodes may have higher sheet resistance than do receive electrodes in certain example embodiments.

## BACKGROUND

**[0003]** A capacitive touch panel often includes an insulator such as glass, coated with a conductive coating. As the human body is also an electrical conductor, touching the surface of the panel results in a distortion of the panel's electrostatic field, measurable as a change in capacitance for example. A transparent touch panel may be combined with a display such as a liquid crystal display (LCD) or LED panel to form a touchscreen. A projected capacitive (PROCAP) touch panel, which may optionally include an LCD or other display, allows finger or other touches to be sensed through a protective layer(s) in front of the conductive coating.

**[0004]** FIGS. 1(a) to 1(g) illustrate an example of a related art projected capacitive touch panel, e.g., see U.S. Patent No. 8,138,425 the disclosure of which is hereby incorporated herein by reference. Referring to FIG. 1(a), substrate 11, x-axis conductor 12 for rows, insulator 13, y-axis conductor 14 for columns, and conductive traces 15 are provided. Substrate 11 may be a transparent material such as glass. X-axis conductors 12 and y-axis conductors 14 are typically indium tin oxide (ITO) which is a transparent conductor. Insulator 13 may be an insulating material (for example, silicon nitride) which inhibits conductivity between x-axis conductors 12 and y-axis conductors 14. Traces 15 provide electrical conductivity between the plurality of conductors and a signal processor (not shown). ITO used for electrodes/traces in small PROCAP touch panels typically has a sheet resistance of at least about 100 ohms/square, which has been found to be too high for certain applications. Moreover, conventional ITO coatings for touch panels are typically highly crystalline and relatively thick and brittle, and thus in applications involving bending such ITO coatings are subject to failure.

**[0005]** Referring to FIG. 1(b), x-axis conductor 12 (e.g., ITO) is formed on substrate 11. The ITO is coated in a continuous layer on substrate 11 and then is subjected to a first photolithography process in order to pattern the ITO into x-axis conductors 12. FIG. 1(c) illustrates cross section A-A' of FIG. 1(b), including x-axis conductor 12 formed on substrate 11. Referring to FIG. 1(d), insulator 13 is then formed on the substrate 11 over x-axis channel(s) of x-axis conductor 12. FIG. 1(e) illustrates cross section B-B' of FIG. 1(d), including insulator 13 which is formed on substrate 11 and x-axis conductor 12. The insulator islands 13 shown in Figs. 1(d)-(e) are formed by depositing a continuous layer of insulating material (e.g., silicon nitride) on the substrate

11 over the conductors 12, and then subjecting the insulating material to a second photolithography, etching, or other patterning process in order to pattern the insulating material into islands 13. Referring to FIG. 1(f), y-axis conductors 14 are then formed on the substrate over the insulator islands 13 and x-axis conductors 12. The ITO for y-axis conductors 14 is coated on substrate 11 over 12, 13, and then is subjected to a third photolithography or other patterning process in order to pattern the ITO into y-axis conductors 14. While much of y-axis conductor material 14 is formed directly on substrate 11, the y-axis channel is formed on insulator 13 to inhibit conductivity between x-axis conductors 12 and y-axis conductors 14. FIG. 1(g) illustrates cross section C-C' of FIG. 1(f), including part of an ITO y-axis conductor 14, which is formed on the substrate 11 over insulative island 13 and over an example ITO x-axis conductor 12. It will be appreciated that the process of manufacturing the structure shown in Figs. 1(a)-(g) requires three separate and distinct deposition steps and three photolithography type processes, which renders the process of manufacture burdensome, inefficient, and costly.

**[0006]** FIG. 1(h) illustrates another example of an intersection of ITO x-axis conductor 12 and ITO y-axis conductor 14 according to a related art projected capacitive touch panel. Referring to FIG. 1(h), an ITO layer is formed on the substrate 11 and can then be patterned into x-axis conductors 12 and y-axis conductors 14 in a first photolithography process. Then, an insulating layer is formed on the substrate and is patterned into insulator islands 13 in a second photolithography or etching process. Then, a conductive layer is formed on the substrate 11 over 12-14 and is patterned into conductive bridges 16 in a third photolithography process. Bridge 16 provides electrical conductivity for a y-axis conductor 14 over an x-axis conductor 12. Again, this process

of manufacture requires at least three deposition steps and at least three different photolithography processes.

**[0007]** The projected capacitive touch panels illustrated in FIGS. 1(a) through 1(h) may be mutual capacitive devices or self-capacitive devices. In a mutual capacitive device, there is a capacitor at every intersection between an x-axis conductor 12 and a y-axis conductor 14 (or metal bridge 16). A voltage is applied to x-axis conductors 12 while the voltage of y-axis conductors 14 is measured (and/or vice versa). When a user brings a finger or conductive stylus close to the surface of the device, changes in the local electrostatic field reduce the mutual capacitance. The capacitance change at every individual point on the grid can be measured to accurately determine the touch location. In a self-capacitive device, the x-axis conductors 12 and y-axis conductors 14 operate essentially independently. With self-capacitance, the capacitive load of a finger or the like is measured on each x-axis conductor 12 and y-axis conductor 14 by a current meter.

**[0008]** As described above, prior art transparent conductors 12 and 14 in touch panels are typically indium tin oxide (ITO), which is problematic for a number of reasons. First, ITO is costly. Second, thin layers of ITO have a high sheet resistance  $R_s$  (typically at least about 100 ohms/square at a given thickness); in other words the conductivity of ITO is not particularly good and its resistivity is high. In order for an ITO layer to have a much lower sheet resistance, the ITO layer must be extremely thick (for example, greater than 300 or 400 nm). However, such a thick layer of ITO is both prohibitively expensive and less transparent. Thus, the high sheet resistance of thin layers of ITO limits their use in layouts requiring long narrow traces on touch panels, with an emphasis on large panels. Accordingly, it will be appreciated that there exists a

need in the art for touch panel electrodes that are of material which does not suffer from the ITO disadvantage combination of high cost and low conductivity at small thicknesses.

#### SUMMARY OF EXAMPLE EMBODIMENTS

**[0009]** Example embodiments of this invention relate to a multi-layer conductive coating that is substantially transparent to visible light, contains at least one conductive layer comprising silver that is sandwiched between at least a pair of dielectric layers, and may be used as an electrode and/or conductive trace in a capacitive touch panel. The multi-layer conductive coating may contain a dielectric layer(s) of or including zirconium oxide (e.g.,  $ZrO_2$ ) and/or silicon nitride in certain example embodiments, and may be used in applications such as capacitive touch panels for controlling showers, appliances, vending machines, electronics, electronic devices, and/or the like. The coating has improved conductivity (e.g., smaller sheet resistance  $R_s$  or smaller emissivity, given a similar thickness and/or cost of deposition) compared to typical ITO coatings used in touch panels. The coating may be used as electrode layers and/or traces in capacitive touch panels such as PROCAP touch panel or any other type of touch panel.

**[0010]** In certain example embodiments, the coating for at least one electrode of the touch panel may have increased resistance, and thus reduced conductivity, compared to pure silver layers of certain coatings, in order to allow the silver-based coating to be more suitable for touch panel electrode applications. The increased resistance, and thus reduced conductivity, of the silver layer(s) in the coating may be achieved by any of several techniques. For example, the increased resistance, and thus the reduced conductivity, of the silver layer(s) in the coating may be achieved by doping the silver with an impurity such as one or more of Zn, Pt, Pd, Ti, Al or the like, and/or by replacing

crystalline zinc oxide directly under and contacting the silver with another material such as a suitable non-crystalline dielectric, amorphous semiconductor, or metal alloy (e.g., NiCr) in order to increase the silver's resistance. Silver with increased resistance may be used for all electrodes and/or traces in the touch panel, or alternatively may be done for only a portion of the electrodes and/or traces in the touch panel.

**[0011]** In certain example embodiments, different electrodes of the touch panel may have different resistance, with respective silver-based structures of various electrodes being different from one another to provide different resistance for different electrodes. For example, transmit electrodes may have higher sheet resistance (ohms/square) than receive electrodes in certain example embodiments. Thus, for example, one, some, or all of the transmit electrodes may be made up of a multi-layer coating including a silver layer that has higher sheet resistance (and thus lower conductivity) compared to pure silver in certain types of coatings, with the higher sheet resistance of the silver-based layer being achieved by doping the silver with an impurity such as one or more of Zn, Pt, Pd, Ti, Al or the like, and/or by replacing crystalline zinc oxide directly under and contacting the silver with another material such as a suitable non-crystalline dielectric, amorphous semiconductor, or metal alloy (e.g., NiCr) in order to increase the silver's resistance. The differences in resistance between transmit and receive electrodes may also be realized by: making conductors of these electrodes different thicknesses, doping silver of the transmit electrodes, and/or providing silver of the transmit electrodes over and directly contacting a layer other than a crystalline zinc oxide based layer.

**[0012]** In an example embodiment of this invention, there is provided a capacitive touch panel, comprising: a glass substrate; a multi-layer transparent conductive coating supported by the glass substrate, the multi-layer transparent conductive coating including at least one conductive layer comprising silver, a dielectric layer located between at least the glass substrate and the conductive layer comprising silver, and a dielectric layer comprising one or more of: zirconium oxide, silicon nitride, and tin oxide located over the conductive layer comprising silver; a plurality of electrodes and a plurality of conductive traces, wherein the electrodes and/or the conductive traces include the multi-layer transparent conductive coating; and processor configured for determining touch position on the touch panel; wherein the plurality of electrodes may or may not be formed substantially in a common plane, and are supported by the glass substrate.

**[0013]** In order to provide higher sheet resistance for a silver-based layer for one or more electrode(s) and/or trace(s), the conductive layer comprising silver may be doped for at least one electrode of the touch panel (e.g., for a transmit electrode(s)). For example, the conductive layer comprising silver may be doped with from about 0.05 to 3.0% (wt.%) [more preferably from 0.1 to 2.0%, and most preferably from 0.1 to 0.5%] of one or more of Zn, Pt, Pd, Ti, and Al.

**[0014]** In order to provide higher sheet resistance for a silver-based layer for one or more electrode(s) and/or trace(s), the multi-layer transparent conductive coating may also or instead include: (a) a layer comprising Ni and Cr (or Ni, Cr and Mo) that contacts the layer comprising silver, wherein the layer comprising Ni and Cr (or Ni, Cr and Mo) may be located between at least the glass substrate and the conductive layer comprising silver, (b) a semiconductor layer that contacts the layer comprising silver, wherein the

semiconductor layer is located between at least the glass substrate and the conductive layer comprising silver, or (c) a substantially amorphous dielectric layer comprising one or more of silicon oxide, silicon nitride, silicon oxynitride, and titanium oxide that contacts the layer comprising silver, wherein the substantially amorphous dielectric layer is located between at least the glass substrate and the conductive layer comprising silver.

#### BRIEF DESCRIPTION OF THE DRAWINGS

**[0015]** FIGS. 1(a) to 1(h) illustrate examples of prior art projected capacitive touch panels.

**[0016]** FIG. 2(a) illustrates a top or bottom plan layout of a projected capacitive touch panel according to an exemplary embodiment, that may contain the coating(s) of Figs. 4, 6, 7, and/or 8 as conductive electrode(s) and/or conductive trace(s).

**[0017]** FIG. 2(b) illustrates a schematic representation of circuitry for the projected capacitive touch panel of Fig. 2(a), 3, 9, and/or 10.

**[0018]** FIG. 3(a) illustrates a top or bottom plan layout of a projected capacitive touch panel according to another example embodiment, that may contain the coating(s) of Figs. 4, 6, 7, and/or 8 as conductive electrode(s) and/or conductive trace(s).

**[0019]** FIG. 3(b) illustrates a top or bottom plan layout of a projected capacitive touch panel electrode arrangement according to another example embodiment, that may contain the coating(s) of Figs. 4, 6, 7, and/or 8 as conductive electrode(s) and/or conductive trace(s).

**[0020]** FIG. 3(c) illustrates a top or bottom plan layout of a projected capacitive touch panel electrode arrangement according to another example embodiment, that may

contain the coating(s) of Figs. 4, 6, 7, and/or 8 as conductive electrode(s) and/or conductive trace(s).

**[0021]** FIG. 3(d) is a perspective view of part of a capacitive touch panel electrode arrangement according to an example embodiment of this invention, where transmit electrodes have higher resistance than do receive electrodes.

**[0022]** FIG. 3(e) is a perspective view of part of a capacitive touch panel electrode arrangement according to an example embodiment of this invention, where transmit electrodes have higher resistance than do receive electrodes.

**[0023]** FIGS. 4(a)-4(g) are cross-sectional views of various silver-inclusive transparent conductive coatings for use in a touch panel of Figs. 2, 3, 7, 8, 9, 10, 11, 12, 13 and/or 14 according to exemplary embodiments of this invention.

**[0024]** FIG. 5 is a percent visible transmission/reflectance vs. wavelength (nm) graph illustrating the visible transmission (TR) percentage and glass side visible reflection (BRA) percentage of a Comparative Example (CE) coating on a glass substrate, compared to those values for the glass substrate alone (Glass-TR, Glass-BRA).

**[0025]** FIG. 6 is a percent visible transmission/reflectance vs. wavelength (nm) graph illustrating the visible transmission (TR) and glass side visible reflection (BRA) of an example coating of Fig. 4(a) according to an example embodiment of this invention on a glass substrate, demonstrating that it is transparent to visible light and has glass side visible reflectance more closely matched to that of the glass substrate compared to the CE in Fig. 5. Fig. 6, like Fig. 5, also illustrates the visible transmission (Glass-TR) and visible reflectance (Glass-BRA) for the glass substrate alone without the coating on it.

**[0026]** FIG. 7 is a cross sectional view of a touch panel assembly according to an example embodiment of this invention, including a touch panel according to any of Figs. 2-4, 6, 8-10 coupled to a liquid crystal panel, for use in electronic devices such as portable phones, portable pads, computers, and/or so forth.

**[0027]** FIG. 8(a) is a percent visible transmission/reflectance vs. wavelength (nm) graph illustrating the visible transmission (CGN-TR or TR) and glass side visible reflection (CGN-BRA or BRA) of an example coating of Fig. 4(b) according to another example embodiment of this invention, demonstrating that it is transparent to visible light and has a glass side visible reflectance more closely matched to the reflectance of the glass substrate alone compared to the CE. Fig. 8(a) also illustrates the visible transmission (Glass-TR) and visible reflectance (Glass-BRA) for just the glass substrate absent the coating.

**[0028]** FIG. 8(b) is a percent visible transmission/reflectance vs. wavelength (nm) graph illustrating the visible transmission (CGN-TR or TR) and glass side visible reflection (CGN-BRA or BRA) of an example coating of Fig. 4(c) according to another example embodiment of this invention, demonstrating that it is transparent to visible light and has a glass side visible reflectance more closely matched to the reflectance of the substrate compared to the CE.

**[0029]** FIG. 9 illustrates a top or bottom plan layout of a low resolution capacitive touch panel according to another example embodiment, that may contain the coating(s) of Figs. 4, 6, 7, 8 as conductive electrode(s) and/or conductive trace(s).

**[0030]** FIG. 10 is a cross sectional view of a low resolution capacitive touch panel according to another example embodiment where the substrate supporting the coating of

this invention of Fig. 9 may be laminated to another substrate (e.g., glass) via a polymer inclusive interlayer such as PVB or EVA.

**[0031]** FIG. 11 is a flow chart of a process for making the transparent conductive coating pattern according to any of Figs. 2, 3, 4, 7, 8, 9, or 10 according to an example embodiment of this invention.

**[0032]** FIG. 12 is a flow chart of a process for making the transparent conductive coating pattern according to any of Figs. 2, 3, 4, 7, 8, 9, or 10 according to another example embodiment of this invention.

**[0033]** FIG. 13 is a flow chart of a process for making the transparent conductive coating pattern according to any of Figs. 2, 3, 4, 7, 8, 9, or 10 according to another example embodiment of this invention.

**[0034]** FIG. 14 is a flow chart of a process for making the transparent conductive coating pattern according to any of Figs. 2, 3, 4, 7, 8, 9, or 10 according to another example embodiment of this invention.

**[0035]** FIG. 15 is a cross sectional view of a capacitive touch panel according to an example embodiment of this invention, including the transparent conductive coating pattern according to any of Figs. 2, 3, 4, 7, 8, 9, or 10 on surface #2, and an additional functional film provided on the surface adapted to be touched by a user.

**[0036]** FIG. 16 is a cross sectional view of a capacitive touch panel according to another example embodiment of this invention, including the transparent conductive coating pattern according to any of Figs. 2, 3, 4, 7, 8, 9, or 10 on surface #3, and an additional functional film provided on the surface adapted to be touched by a user.

**[0037]** FIG. 17 is a cross sectional view of a monolithic capacitive touch panel according to another example embodiment of this invention, including the transparent conductive coating pattern according to any of Figs. 2, 3, 4, 7, 8, 9, or 10 on surface #2, and an additional functional film provided on the surface adapted to be touched by a user.

#### DETAILED DESCRIPTION OF EXEMPLARY EMBODIMENTS

**[0038]** A detailed description of exemplary embodiments is provided with reference to the accompanying drawings. Like reference numerals indicate like parts throughout the drawings.

**[0039]** Example embodiments of this invention relate to a multi-layer conductive coating 41 that is substantially transparent to visible light, contains at least one conductive layer comprising silver 46 that is sandwiched between at least a pair of layers such as dielectric layers, and may be used as an electrode and/or conductive trace in a capacitive touch panel. Example multi-layer transparent conductive coatings 41 are shown in Figs. 4(a)-(g). The multi-layer conductive coating 41 may be used in applications such as capacitive touch panels for controlling showers (e.g., water on/off control, water temperature control, and/or steam control), appliances, vending machines, music control, thermostat control, electronics, electronic devices, and/or the like. The zirconium oxide and/or DLC layers discussed herein provide for scratch resistance, and resistance to stains and cleaning chemicals in applications such as shower door/wall touch panel applications. In certain example embodiments, the coating includes a silver layer(s) 46 and may be used as an electrode(s) and/or conductive trace(s) in a capacitive touch panel so as to provide for an electrode(s) transparent to visible light but without much visibility due to closely matching visible reflection of the coating on the substrate

to that of an underlying substrate in areas where the coating is not present. The coating 41 has improved conductivity (e.g., smaller sheet resistance  $R_s$  or smaller emissivity, given a similar thickness and/or cost of deposition) compared to typical ITO coatings used in touch panels. The coating may be used as electrode layers and/or traces in capacitive touch panels such as PROCAP touch panels or any other type of touch panel. The touch panels discussed herein, including the electrodes and traces of the multi-layer coating 41, preferably have a visible transmission (Ill. A, 2 deg. Obs.) of at least 50%, more preferably of at least 60%, and most preferably of at least 70%.

**[0040]** In certain example embodiments, the coating 41 for at least one electrode in the touch panel may have increased resistivity, and thus reduced conductivity, compared to pure silver layers of certain coatings, in order to allow the silver-based coating to be more suitable for certain touch panel electrode applications. The increased sheet resistance, and reduced conductivity, of the silver layer(s) 46 in the coating 41 may be achieved by any of several techniques. For example, the increased sheet resistance, and reduced conductivity, of the silver layer(s) 46 in the coating may be achieved by doping the silver with an impurity such as one or more of Zn, Pt, Pd, Ti, Al or the like. For example, the silver layer 46 of any of Figs. 4(a)-4(g) may be doped with from about 0.05 to 3.0%, more preferably from about 0.1 to 2.0%, and most preferably from about 0.1 to 0.5% (wt. %), of one or more of Zn, Pt, Pd, Ti, Al, or a combination thereof. The increased sheet resistance, and reduced conductivity, of the silver layer(s) 46 may also or instead be achieved by replacing crystalline zinc oxide 44 directly under and contacting the silver with another material such as a suitable non-crystalline dielectric, amorphous semiconductor, or metal alloy (e.g., NiCr, NiCrMo, etc.) in order to increase the silver's

resistance (e.g., see the NiCr based layer under the silver in Fig. 4(f)). The increased sheet resistance, and reduced conductivity, of the silver based layer(s) 46 may be achieved by, for example, one or both of: (a) doping the silver, and/or (b) replacing crystalline zinc oxide 44 directly under the silver with a suitable non-crystalline dielectric, amorphous semiconductor, or metal alloy. Silver with increased sheet resistance may be used for all electrodes and/or traces in the touch panel, or alternatively may be used for only a portion of the electrodes and/or traces in the touch panel.

**[0041]** In certain example embodiments, different electrodes 41 of the touch panel may be designed to have different sheet resistances, with respective silver-based structures of various electrodes being different from one another to provide different sheet resistances for different electrodes. For example, transmit electrodes (T) may have higher sheet resistance than receive electrodes (R) in certain example embodiments. Thus, for example, one, some, or all of the transmit electrodes (T) in any embodiment herein may be made up of a multi-layer coating 41 including a silver layer 46 that has higher sheet resistance (and thus lower conductivity) compared to pure silver in certain types of coatings, with the higher sheet resistance of the silver-based layer 46 being achieved by doping the silver with an impurity such as one or more of Zn, Pt, Pd, Ti, Al or the like, and/or by replacing crystalline zinc oxide directly under and contacting the silver with another material such as a suitable non-crystalline dielectric, amorphous semiconductor, or metal alloy (e.g., NiCr) in order to increase the silver based layer's sheet resistance. The receive electrodes may be designed to have a lower sheet resistance than the transmit electrodes, such as by not doping the silver based receive electrodes and/or by providing them on and contacting a crystalline or substantially crystalline layer

of or including zinc oxide 44 which may optionally be doped with from about 1-10%, more preferably from about 1-5% aluminum.

**[0042]** In certain example embodiments of this invention, there is provided a capacitive touch panel that includes a glass substrate 40; a multi-layer transparent conductive coating 41 supported by the glass substrate 40. The multi-layer transparent conductive coating 41 may include at least one conductive layer comprising silver 46, a layer 44 under the conductive layer comprising silver 46, and a dielectric layer comprising one or more of silicon nitride 50, tin oxide 49, titanium oxide 48, NiCrO<sub>x</sub> 47 and/or zirconium oxide 75 over the conductive layer comprising silver 46, a plurality of electrodes and a plurality of conductive traces, wherein the electrodes and/or the conductive traces of the touch panel are made of the multi-layer transparent conductive coating 41. A processor (including processing circuitry) may be provided for detecting touch position on the touch panel; wherein the electrodes, and the conductive traces may be formed substantially in a common plane substantially parallel to the glass substrate 40, and a plurality of the electrodes are electrically connected to the processor by conductive traces. The glass substrate may be heat treated (e.g., thermally tempered). For one or more electrode(s) and/or trace(s), increased resistance, and reduced conductivity, of the silver in coating 41 compared to pure silver in certain coatings may be achieved by, for example, one or both of: (a) doping the conductive silver layer 46 with an impurity such as one or more of Zn, Pt, Pd, Ti, Al, or a combination thereof, and/or (b) replacing crystalline zinc oxide directly under the conductive silver 46 with a suitable non-crystalline dielectric [e.g., silicon oxide (e.g., SiO<sub>2</sub>), silicon oxynitride, silicon nitride

(e.g., Si<sub>3</sub>N<sub>4</sub>), titanium oxide (e.g., TiO<sub>2</sub>), or zinc stannate], amorphous semiconductor (e.g., a-Si), or metal alloy (e.g., NiCr, NiCrMo, or the like).

**[0043]** The multi-layer transparent conductive coating 41 (and thus silver based layer 46 in certain example embodiments) may have a sheet resistance ( $R_s$ ) of less than or equal to about 40 ohms/square, more preferably less than or equal to about 20 ohms/square, more preferably less than or equal to about 15 ohms/square, and most preferably less than or equal to about 10 ohms/square. The multi-layer transparent conductive coating 41, and thus silver based layer 46, may have a resistivity of from  $30 \times 10^{-7}$  to  $90 \times 10^{-7} \Omega \cdot \text{cm}$ , more preferably from  $40 \times 10^{-7}$  to  $80 \times 10^{-7} \Omega \cdot \text{cm}$  (ohm·cm).

**[0044]** FIG. 2(a) illustrates a top or bottom plan layout of a projected capacitive touch panel according to an exemplary embodiment, that may contain the multi-layer conductive transparent coating 41 of Figs. 4, 6, 7, and/or 8 as conductive electrode(s) x, y and/or conductive trace(s) 22. Referring to FIG. 2(a), touch panel 20 is provided. Touch panel 20 includes a matrix of electrodes x, y including n columns and m rows, provided on a substrate 40 such as a glass substrate. The glass substrates may also include an antireflective (AR) layer in certain example embodiments. The matrix of row/column electrodes x, y may be provided on the side of the substrate (e.g., glass substrate 40) that is opposite the side touched by person(s) using the touch panel, in order to prevent corrosion of the silver-based coating 41 by human finger touches. In other words, when the touch panel is touched by a finger, stylus, or the like, the glass substrate 40 is typically located between (a) the finger and (b) the matrix of row/column electrodes x, y and conductive traces 22. However, in certain embodiments the matrix of row/column electrodes x, y and traces may be provided on the side of the substrate (e.g., glass

substrate 40) that is touched by person(s) using the touch panel, such as in shower door application, glass wall applications, and/or the like, for example in situations where only one glass substrate is provided. Change in capacitance between adjacent row and column electrodes in the matrix as a result of the proximity of a finger or the like is sensed by the electronic circuitry, and the connected circuitry can thus detect where the panel is being touched by a finger or the like. For example, referring to Fig. 2(a), row 0 includes row electrodes  $x_{0,0}$ ,  $x_{1,0}$ ,  $x_{2,0}$ , etc., through  $x_{n,0}$  and columns 0, 1 and 2 respectively include column electrodes  $y_0$ ,  $y_1$ ,  $y_2$ , etc., through  $y_n$ . Optionally, the x electrodes in a column direction may also be grouped for column sensing. The number of row and column electrodes is determined by the size and resolution of the touch panel. In this example, the top-right row electrode is  $x_{n,m}$ . Each row electrode  $x_{0,0}$ - $x_{n,m}$  of touch panel 20 is electrically connected to interconnect area 21 and corresponding processing circuitry/software by a conductive trace 22. Each column electrode  $y_0$ - $y_n$  is also electrically connected to interconnect area 21 and corresponding processing circuitry/software, either directly or by a conductive trace. The conductive traces 22 are preferably formed of the same transparent conductive material (multilayer conductive transparent coating 41) as the row and column electrodes (e.g., same material as at least row electrodes  $x_{0,0}$ ,  $x_{1,0}$ ,  $x_{2,0}$ , etc.). Thus, in certain example embodiments, the matrix of row and column electrodes x, y and corresponding traces 22 can be formed on the substrate (e.g., glass substrate) 40 by forming the coating 41 (e.g., by sputter-depositing the coating 41) on the substrate 40 and by performing only one (or maximum two) photolithography and/or other patterning process in order to pattern the coating 41 into the conductive electrodes x, y and/or conductive traces 22. In certain example

embodiments, the silver-inclusive coating (e.g., see example coating 41 in Figs. 4(a)-(g)) is sputter deposited on the glass substrate 40 and is then subjected to photolithography and/or laser patterning to pattern the silver-inclusive coating 41 into traces 22, row electrodes  $x_{0,0}$ ,  $x_{1,0}$ ,  $x_{2,0}$ ,  $x_{0,1}$ ,  $x_{0,2}$ ,  $x_{0,3}$ , etc. through  $x_{n,m}$ , and column electrodes  $y_0$ - $y_n$ . Because the row electrodes  $x_{0,0}$ - $x_{n,m}$ , column electrodes  $y_0$ - $y_n$ , and traces 22 do not overlap as viewed from above/below, the row electrodes  $x_{0,0}$ - $x_{n,m}$ , column electrodes  $y_0$ - $y_n$ , and traces 22 may be formed on the same plane parallel (or substantially parallel) to glass substrate 40 on which the electrodes and traces are formed. And no insulating layer between electrodes  $x$  and  $y$  is needed in certain example embodiments. Significant portions of traces 22 may also be parallel (or substantially parallel) to the column electrodes in the plane parallel (or substantially parallel) to the substrate 40. Accordingly, touch panel 20 may be made via a smaller number of photolithography or laser patterning steps while achieving traces that achieve sufficient transparency and conductivity, thereby reducing production costs and resulting in a more efficient touch panel for use in a display assembly or the like.

**[0045]** FIG. 2(b) illustrates a schematic representation of circuitry for the touch panel 20 illustrated in FIG. 2(a), according to exemplary embodiments. In touch panel 20, there is a capacitance between each row electrode and the adjacent column electrode (for example, between row electrode  $x_{0,0}$  and column electrode  $y_0$ ). This capacitance can be measured by applying a voltage to a column electrode (for example, column electrode  $y_0$ ) and measuring the voltage of an adjacent row electrode (for example, row electrode  $x_{0,0}$ ). When a user brings a finger or conductive stylus close to touch panel 20, changes in the local electrostatic field reduce the mutual capacitance. Thus, one may be

considered a transmit electrode  $y_0$  and the other a receive electrode  $x_{0,0}$ . The capacitance change at individual points on the surface can be measured by measuring each pair of row electrodes and column electrodes in sequence. The traces 22 of each row electrode in the same row (for example, the traces 22 of row electrodes  $x_{0,0}$ ,  $x_{1,0}$ ,  $x_{2,0}$ , etc., through  $x_{n,0}$  of row 0) may be electrically connected together (as shown in Fig. 2(b)). The interconnection of the first row segments to each other, second row segments to each other, etc., may be made on a flexible circuit(s) attached at the periphery of the touch panel in the interconnection area, so that no cross-overs are needed on the glass substrate 40. In that instance, a voltage is applied to a column electrode and the voltage of each row is measured in sequence before the process is repeated with a voltage applied to another column. Alternatively, each trace 22 may be connected to signal processor 25 and the voltage of each trace 22 may be measured individually. The same capacitance may be measured by applying a voltage to a row electrode and measuring the voltage on an adjacent column electrode rather than applying a voltage to a column electrode and measuring the voltage of an adjacent row electrode. Signal processing (for example, applying and measuring voltages, measuring the capacitance between adjacent electrodes, measuring changes in capacitance over time, outputting signals in response to user inputs, etc.) may be performed by signal processor 25. Signal processor 25 may be one or more hardware processors, may include volatile or non-volatile memory, and may include computer-readable instructions for executing the signal processing. Signal processor 25 is electrically connected to the column electrodes  $y_0$ - $y_n$  and electrically connected to the row electrodes  $x_{0,0}$ - $x_{n,m}$  through the traces 22. Signal processor 25 may or may not be

located on the same plane as row electrodes  $x_{0,0}$ - $x_{n,m}$ , column electrodes  $y_0$ - $y_n$ , and traces 22 (for example, in interconnect area 21 of FIG. 2(a)).

**[0046]** FIG. 3(a) illustrates a top or bottom plan layout of a projected capacitive touch panel according to another example embodiment, that includes the coating 41 of any of Figs. 4(a)-(g), 6, 7, and/or 8 patterned to form the conductive electrode(s)  $x$ ,  $y$  and/or conductive trace(s) 22. Referring to FIG. 3(a), touch panel 30 is similar to touch panel 20 of FIG. 2(a), except that touch panel 30 is divided into upper section 31 and lower section 32, each of which includes a matrix of electrodes  $x$ ,  $y$  including  $n$  columns and  $m$  rows. For example, row 0 of upper section 31 includes row electrodes  $x_{0,0}$ ,  $x_{1,0}$ ,  $x_{2,0}$ , etc., through  $x_{n,0}$ . Upper section 31 also includes column electrodes  $y_0$ ,  $y_1$ ,  $y_2$ , etc., through  $y_n$ . Likewise, lower section 32 would also include row electrodes, and column electrodes  $y_0$ - $y_n$  that may be electrically separate from the column electrodes  $y_0$ - $y_n$  of the upper section 31. Thus, lower section 32 also includes a matrix of row electrodes including  $n$  columns and  $m$  rows, and  $n$  column electrodes. Lower section 32 may have more or less rows than upper section 31 in different example embodiments. The number of row and column electrodes of touch panel 30 is determined by the size and resolution of the touch panel. Each column electrode of upper section 31 is electrically connected to interconnect area 21, and each row electrode of upper section 31 is electrically connected to interconnect area 21 by a trace 22. As with the Fig. 2 embodiment, traces may or may not be used for connecting the column electrodes of upper section 31 to the interconnect area. Each column electrode of lower section 32 is electrically connected to interconnect area 21' and each row electrode of lower section 32 is electrically connected to interconnect area 21' by a trace 22. Again, traces may or may not be used for connecting

the column electrodes of the lower section 32 to the interconnect area 21'. Still referring to Fig. 3(a), touch panel 30 is similar to touch panel 20 in that there is a capacitance between each row electrode and the adjacent column electrode which may be measured by applying a voltage to a column electrode and measuring the voltage of an adjacent row electrode (or, alternatively, by applying a voltage to a row electrode and measuring the voltage of an adjacent column electrode). When a user brings a finger or conductive stylus close to touch panel 30, changes in the local electrostatic field reduce the mutual capacitance. The capacitance change at individual points on the surface can be measured by measuring the mutual capacitance of each pair of row electrodes and column electrodes in sequence.

**[0047]** FIGS. 3(b) and 3(c) illustrate top or bottom plan layouts of a portion of a projected capacitive touch panel according to further example embodiments, that includes the coating 41 of any of Figs. 4(a)-(g), 6, 7, and/or 8 patterned to form the conductive electrode(s) x, y and/or conductive trace(s) 22. An example electrode configuration of a pro-cap sensor may utilize a single transparent conductive coating 41 patterned into the form of parallel electrode stripes as shown in either Fig. 3(b) or Fig. 3(c). In Fig. 3(b), the electrodes stripes are fairly straight, while in Fig. 3(c) one or more of the electrode stripes may have a zig-zag shape. These electrode stripes correspond to the alternating receiving (R) and transmitting (T) electrodes connected to a driver. The driver charges the transmit/transmitting electrodes (T) with alternating current. The position of a receive/receiving electrode (R) allows the detection of the X coordinate upon touch from a finger, while the output voltage from the transmitting electrode (T) allows the detection of the Y coordinate, thus enabling the positional identification of a single touch or

multiple touches. It is desirable to have a set of receiving electrodes (R) made from a material with a low sheet resistance ( $R_s$ ), such as silver (e.g., lower  $R_s$  than ITO of a similar thickness), so that the voltage drop along each electrode is minimal/reduced. It is desired, at the same time, that the transmitting electrodes (T) have a higher sheet resistance (reduced conductivity), compared to pure silver in certain coatings so there is a substantial voltage gradient along each transmit electrode to increase the noise-to-signal ratio. Thus, there are competing interests with respect to the sheet resistance of the two sets of electrodes, namely receive electrodes (R) and transmit electrodes (T). For the receive and transmit electrodes, silver-based layer 46 in a coating 41 as a substitute for the commonly used indium-tin-oxide (ITO) is desirable, for a much more conductive electrode material. The silver layer 46 may be sandwiched between at least two dielectric layers, and may use an underlayer (e.g., crystalline zinc oxide 44, which may be doped with Al for example) to attain a higher silver conductivity due to a better crystalline orientation. In this case, the low sheet resistance of silver allows large formats of the touch screen, but may sometimes be too low for effective use of transmitting electrodes. To address this discrepancy, one of the transmitting electrode(s) architectures may use a zigzag pattern as shown in Fig. 3(c) to reduce the width of each electrode, while increasing its effective length and, thus increasing its sheet resistance. Such a reduction in width, however, makes the transmitting electrode prone to defects, such as scratches, particulates, macro-inclusions, etc. Thus, in certain example embodiments of this invention, embodiments are provided reducing the conductivity of the silver layer 46 to make it conductive enough for the receiving electrodes and, at the same time, resistive enough for an effective use of the transmitting electrodes. Thus, the same silver structure

may be used for conductive layer(s) 46 for both the transmit and receive electrodes in certain example embodiments. The increase in sheet resistance of the silver layer 46 may be done by one of the following methods or by their combination: (a) doping the conductive silver layer 46 with an impurity such as one or more of Zn, Pt, Pd, Ti, Al, or a combination thereof, and/or (b) replacing crystalline zinc oxide directly under the conductive silver 46 with a suitable non-crystalline dielectric [e.g., silicon oxide (e.g., SiO<sub>2</sub>), silicon oxynitride, silicon nitride (e.g., Si<sub>3</sub>N<sub>4</sub>), titanium oxide (e.g., TiO<sub>2</sub>), or zinc stannate], amorphous semiconductor (e.g., a-Si), or metal alloy (e.g., NiCr, NiCrMo, or the like). Doping with some impurities may help make the silver layer 46 more resistive to oxidation and/or environmental degradation.

**[0048]** Because the row electrodes and column electrodes x, y illustrated in FIGS. 3(a)-3(c) do not overlap in certain example embodiments, the row electrodes and column electrodes may (or may not) be formed on the same plane by patterned transparent conductive coating 41, in the manner explained above in connection with Fig. 2. Accordingly, electrode structure x, y for the touch panel 30 of any of Figs. 3(a)-3(c) may be thin in nature and may be patterned with one process (for example, one photolithography process or one laser patterning process) which reduces the production cost of the projected capacitive touch panel.

**[0049]** However, in certain example embodiments, different silver structure may be used for receive electrodes compared to that used for transmit electrodes of the touch panel. This is applicable to any embodiment herein. As explained above, referring to Figs. 3(b)-3(e) for example, it is desirable to have a set of receiving electrodes (R) made from a material with a low sheet resistance ( $R_s$ ) and low resistivity, such as silver (e.g.,

lower  $R_s$  and lower resistivity than ITO of a similar thickness), so that the voltage drop along each electrode is minimal/reduced, while at the same time it is desirable for the transmitting electrodes (T) to have a higher sheet resistance and higher resistivity (reduced conductivity), compared to pure silver in certain coatings, so there is a substantial voltage gradient along each transmit electrode (T) to increase the noise-to-signal ratio. Thus, there are competing interests with respect to the sheet resistance of the two sets of electrodes, namely receive electrodes (R) and transmit electrodes (T). Therefore, in certain example embodiments, different electrodes 41 of the touch panel may be designed to have different sheet resistances.

**[0050]** For example, referring to any of Figs. 3(b)-3(e) for example, transmit electrodes (T) may have higher sheet resistance than receive electrodes (R) in certain example embodiments. For example, transmit electrodes (T) may have a sheet resistance of from about 15-50 ohms/square, more preferably from about 20-50 ohms/square, and most preferably from about 20-40 ohms/square. And receive electrodes (R) may have a sheet resistance of from about 1-14 ohms/square, more preferably from about 2-12 ohms/square, and most preferably from about 2-10 ohms/square. In certain example embodiments, the transmit electrodes (T) may have a sheet resistance at least 1 ohm/square higher, more preferably at least 5 ohms/square (more preferably at least 10, 15 or 20 ohms/square) higher, than the sheet resistance of the receive electrodes (R). This may also apply to any other embodiment herein, and may apply to some or all transmit and receive electrodes. For example, one, some, or all of the transmit electrodes (T) in any embodiment herein may be made up of a multi-layer coating 41 including a silver layer 46 that has higher sheet resistance (and thus lower conductivity) compared to

pure silver in certain types of coatings, with the higher sheet resistance of the silver-based layer 46 for transmit electrodes (T) being achieved by doping the silver with an impurity such as one or more of Zn, Pt, Pd, Ti, Al or the like, and/or by replacing crystalline zinc oxide directly under and contacting the silver with another material such as a suitable non-crystalline dielectric, amorphous semiconductor, or metal alloy (e.g., NiCr) in order to increase the silver's resistance as discussed above. The receive electrodes (R) may be designed to have a lower sheet resistance than the transmit electrodes (T), such as by not doping the silver based layer 46 in the coating 41 of the receive electrodes and/or by providing them on and contacting a crystalline or substantially crystalline layer of or including zinc oxide 44 which may optionally be doped with from about 1-10%, more preferably from about 1-5% aluminum.

**[0051]** In other example embodiments, the different resistance of the transmit (T) and receive (R) electrodes may be achieved by making the silver-based conductive layer 46 of these respective electrodes at different thicknesses (with the same or different structure/material) in order to adjust the respective sheet resistance of each electrode based on thickness. Different thicknesses for the silver based layers 46 of the different electrodes (T) and (R) may (but need not) be used in combination with other techniques, such as doping and adjustment of the layer directly under the silver discussed herein.

**[0052]** Fig. 3(d) illustrates an example embodiment where the transmit (T) and receive (R) electrodes, with their different respective sheet resistances, are parallel and overlap one another. Thus, the (T) and (R) electrodes are on different planes in the Fig. 3(d) embodiment. In the Fig. 3(d) embodiment, the (T) and (R) electrodes may be formed using different multi-layer coatings 41, or alternatively a single multi-layer

coating 41 with two different silver based layers 46 having different resistance may be used to form overlapping (T) and (R) electrodes. In embodiments where the (T) and (R) electrodes are formed using a single multi-layer coating 41 with two different silver based layers 46, the double silver multi-layer coating may be formed, for example, by repeating the layer stacks of any of Figs. 4(a)-4(g) on top of the illustrated coating so as to provide a coating including two silver based layers 46. For instance, referring to Fig. 4(a), a double silver coating 41 could be made up of the following layers moving outwardly from the glass substrate 40: 40/43/44/46/47/48/49/50/43/44/46/47/48/49/50. Referring to Fig. 4(f), a double silver coating 41 may be formed of the following layers moving away from the glass substrate 40: 40/61/101/46/47/50/61/101/46/47/50, as another example. In each of these example double silver coatings, the bottom conductive silver based layer 46 may be used for one of the electrodes (transmit or receive), and the top silver based layer 46 may be used for the other of the electrodes – this is particularly useful in embodiments such as Fig. 3(d) where the T and R electrodes are parallel, overlap, and are directly over each other.

**[0053]** Fig. 3(e) illustrates an example embodiment where the transmit (T) and receive (R) electrodes, with their different respective sheet resistances, are parallel and do not overlap one another. Thus, the (T) and (R) electrodes may be in the same plane, or on different planes, in the Fig. 3(d) embodiment. In the Fig. 3(e) embodiment, since the transmit and receive electrodes do not overlap, the (T) and (R) electrodes may be formed using different multi-layer coatings 41. In Figs. 3(d)-(e) for example, the transmit and receive electrodes may generally be of the same shape in certain example embodiments, and may be formed via the same or different patterning steps. While the transmit and

receive electrodes are parallel or substantially parallel to each other in Figs. 3(d)-(e), in other example embodiments the transmit and receive electrodes of the touch panel may be perpendicular to each other and overlap each other.

**[0054]** In certain example embodiments of this invention, transmit (T) electrodes may have a sheet resistance

**[0055]** As one of ordinary skill in the art would recognize, touch panels 20 and 30 described are not limited to the orientations described above and shown in FIGS. 2-3. In other words, the terms “row,” “column” “x-axis,” and y-axis” as used in this application are not meant to imply a specific direction. Touch panel 20 of FIG. 2(a), for example, may be modified or rotated such that interconnect area 21 is located in any part of touch panel 20.

**[0056]** In the Fig. 2-3 embodiments, narrow transparent conductive traces (e.g., 22) may be routed to electrically connect electrodes to interconnect area 21 (and interconnect area 21'). Because of the large resistance of the narrow ITO traces, narrow ITO traces may only been used in small touch panels, such as for smart phones. To use one of the layouts illustrated in FIGS. 2(a) and 3 on larger touch panels (for example, measuring more than 10 inches diagonally) or otherwise, a transparent conductive coating 41 with lower sheet resistance (compared to ITO at like thickness) is used. The silver inclusive coating 41 shown in Fig. 4 (any of Figs. 4(a)-(g)) for use in forming the electrodes and traces of Figs. 2-3 is advantageous in this respect because it has a much lower sheet resistance (and thus more conductivity) than typical conventional ITO traces/electrodes.

**[0057]** Examples of multilayer silver-inclusive transparent conductive coatings (TCC) 41 with low sheet resistance, for forming any and/or all of the conductive electrodes and/or conductive traces of Figs. 2-3 are illustrated in Fig. 4 (Figs. 4(a)-4(g)) according to exemplary embodiments of this invention. The low sheet resistance and high transparency of the TCC 41 allow the TCC to form the long narrow traces 22 as well as the row and column electrodes x, y and/or transmit/receive electrodes for example.

**[0058]** Referring to FIG. 4(a), multilayer transparent conductive coating 41 in an example embodiment is provided, either directly or indirectly, on substrate 40. Substrate 40 may be, for example, glass. In alternative embodiments discussed below, an anti-reflective (AR) coating may be provided between the substrate 40 and the coating 41. Coating 41 may include, for example, a dielectric high index layer 43 of or including a material such as titanium oxide or niobium oxide, which may include titanium oxide (e.g., TiO<sub>2</sub> or other suitable stoichiometry); a dielectric layer of or including zinc oxide 44, optionally doped with aluminum, to be in contact with the silver-based layer; a silver-based conductive layer 46 on and directly contacting the zinc oxide based layer 44; an upper contact layer 47 including nickel and/or chromium or other suitable material which may be oxidized and/or nitrided, that is over and contacting the silver-based conductive layer 46; a dielectric high index layer 48 of or including a material such as titanium oxide or niobium oxide, which may include titanium oxide (e.g., TiO<sub>2</sub> or other suitable stoichiometry); a dielectric layer 49 of or including tin oxide (e.g., SnO<sub>2</sub>); and a dielectric layer 50 of or including silicon nitride and/or silicon oxynitride which may be doped with from 1-8% Al for example. Each of the layers in the coating 41 is designed to be substantially transparent (e.g., at least 70% or at least 80% transparent) to visible light.

The dielectric high index layer 43 may be fully oxidized or sub-stoichiometric in different example embodiments. The silver layer 46 may or may not be doped with other materials (e.g., Pd, Pt, Zn, Ti and/or Al) in certain example embodiments, as discussed herein. Instead, of zinc oxide, layer 44 may be of or include Upper contact layer 47 may be of or include materials such as NiCr, NiCrO<sub>x</sub>, NiCrN<sub>x</sub>, NiCrON<sub>x</sub>, NiCrMo, NiCrMoO<sub>x</sub>, TiO<sub>x</sub>, or the like. The zinc oxide of layer 44 directly under the conductive silver 46 may be replaced with an amorphous or substantially amorphous dielectric [e.g., silicon oxide (e.g., SiO<sub>2</sub>), silicon oxynitride, silicon nitride (e.g., Si<sub>3</sub>N<sub>4</sub>), titanium oxide (e.g., TiO<sub>2</sub>), or zinc stannate], an amorphous semiconductor (e.g., a-Si), or a metal alloy (e.g., NiCr, NiCrMo, or the like) as layer 44, in order to adjust the conductivity of the silver based layer 46 as discussed herein.

**[0059]** The coating 41 is designed to achieve good conductivity via conductive silver based layer 46, while optionally at the same time to reduce visibility by more closely matching its visible reflectance (glass side and/or film side visible reflectance) to the visible reflectance of the supporting substrate 40. Note that the glass side visible reflectance is measured from the side of the coated glass substrate opposite the coating, whereas the film side visible reflectance is measured from the side of the coated glass substrate having the coating. Substantial matching of the visible reflectance of the coating 41 and the visible reflectance of the supporting glass substrate 40 reduces visibility of the electrodes and traces formed of the coating material 41. Surprisingly and unexpectedly, it has been found that adjusting certain dielectric thicknesses of the Fig. 4(a) coating can surprising improve (reduce) the visibility of the coating 41 and thus

make the patterned electrodes and traces of the touch panel less visible to users and therefore more aesthetically pleasing.

**[0060]** While various thicknesses and materials may be used in layers in different embodiments of this invention, example thicknesses and materials for the respective sputter-deposited layers of coating 41 on the glass substrate 40 in the Fig. 4(a) embodiment are as follows, from the glass substrate outwardly:

Table 1: Fig. 4(a) Transparent Conductive Coating

Ref	Material	Preferred Thickness (Å)	More Preferred Thickness (Å)	Example Thickness (Å)
43	TiO <sub>x</sub>	130-185	150-185	177
44	ZnO	50-140	60-100	83
46	Ag	90-160	115-140	124
47	NiCrO <sub>x</sub>	15-50	15-30	20
48	TiO <sub>x</sub>	10-60	15-35	23
49	SnO <sub>2</sub>	80-220	110-150	130
50	Si <sub>x</sub> N <sub>y</sub>	300-400	300-320	305

**[0061]** It is noted that the above materials for coating 41 in the Fig. 4(a) embodiment are exemplary, so that other material(s) may instead be used and certain layers may be omitted in certain example embodiments. This coating has both low sheet resistance, and has layers designed to reduce visibility of the coating 41 on the supporting glass substrate 40. In certain exemplary embodiments, glass substrate 40 with coating 41 thereon may be heat treated (e.g., thermally tempered), e.g., after coating, or chemically strengthened before coating.

**[0062]** In Figs. 4(a)-(g), silver-inclusive coating 41 is inexpensive, has a low sheet resistance (preferably less than 40 ohms/square, more preferably less than 20 ohms/square, even more preferably less than about 15 or 10 ohms/square) and maintains high visible transmittance (preferably at least 60%, more preferably at least 70%, more preferably at least 80%, and most preferably at least 84%). The coating 41 is preferably deposited on substantially the entirety of the major surface of the glass substrate 40, and then patterned to form the electrodes and/or traces. For example, the example display assembly shown in Fig. 7 includes a touch panel (20 or 30 or 50) mounted on a liquid crystal display panel (100-300). In the Fig. 7 embodiment, one or more of the row electrodes, column electrodes, and traces may be formed from coating 41 on the surface of the glass substrate 40 opposite the finger, and the touch panel (20, 30 or 50) may be adhered to the LCD panel via an index-matching adhesive layer 85. The LCD panel includes first and second substrates (e.g., glass substrates) 100, 200 with a liquid crystal layer 300 provided therebetween. In order to form a touchscreen, the touch panel 20, 30 may optionally be mounted on the LCD panel with a small air gap or bonded to the display with an index-matching adhesive 85. Thus, reference numeral 85 in Fig. 7 represents either an air gap or an index matching adhesive between the display and the touch panel. It is noted that for the measurements taken for Figs. 5-6 and 8(a)-(b), an air gap 85 was assumed so that the coating 41 was adjacent an air gap 85. In air gap embodiments, the periphery of the substrate 40 supporting the coating 41 may be bonded to the liquid crystal panel via adhesive or any other suitable type of edge seal material.

**[0063]** The pixel pitch for projected capacitive touch panels may, for example, be in the range of from about 6 to 7 mm. Touch location can be determined more accurately

for example, to about 1 mm, by signal processing and interpolation. If the line width/spacing for the traces 22 is approximately 10 μm to 20 μm, it can be calculated that a projected capacitive touch panel of at least 20 inches (measured diagonally) is possible for a TCC sheet resistance of about 4 ohms/square. Further optimization of the routing, signal processing and/or noise suppression allows for production of even larger touch panels (for example, up to 40 or 50 inches diagonally). This invention is also applicable to smaller touch panels in certain example embodiments.

**[0064]** EXAMPLE 1 vs. COMPARATIVE EXAMPLE (CE)

**[0065]** Surprisingly and unexpectedly, it has been found that adjusting certain dielectric thicknesses of the Fig. 4(a) coating can surprisingly reduce the visibility of the coating 41 on the supporting substrate 40, and thus make the electrodes and traces of the touch panel less visible to users and therefore the overall panel more aesthetically pleasing. This is evidenced, for example, by the comparison below between a Comparative Example (CE) and Example 1 of this invention, where the coatings include from the glass substrate outwardly:

Table 2: Comparative Example (CE) vs. Example 1

Ref	Material	Comparative Example (CE) Thickness (Å)	Example 1 Thickness (Å)
43	TiO <sub>x</sub>	194	177
44	ZnO	83	83
46	Ag	124	124
47	NiCrO <sub>x</sub>	20	20
48	TiO <sub>x</sub>	23	23
49	SnO <sub>2</sub>	30	130

50	Si <sub>x</sub> N <sub>y</sub>	295	305
----	--------------------------------	-----	-----

**[0066]** It can be seen from Table 2 above that the only difference between Example 1 according to this invention and the Comparative Example (CE) are the thicknesses of the dielectric layers 43 and 50. Surprisingly and unexpectedly, it has been found that adjusting the thicknesses of layers 43 and 50 the coating can surprising reduce the visibility of the coating 41 areas on the supporting glass substrate 40 by more closely matching the visible reflectance (e.g., glass side visible reflectance) of the coating 41 on the glass substrate to the visible reflection of the glass substrate 40 alone, and thus make the electrodes and traces of the touch panel less visible to users and therefore more aesthetically pleasing. This is shown in Figs. 5-6 and also in the tables below.

**[0067]** FIG. 5 is a percent transmission/reflectance vs. wavelength (nm) graph illustrating the visible transmission (TR) percentage and glass side visible reflection (BRA) percentage of the Comparative Example (CE) coating on a glass substrate, compared to those values for the glass substrate alone (Glass-TR, Glass-BRA). Note that Fig. 5 includes the visible spectrum, as well as some wavelength outside the visible spectrum. The line plot with the “x” through it in Fig. 5 is the glass side visible reflection of the CE coating on the glass substrate 40 (i.e., reflection taken from the side of the finger in Fig. 7), and the line plot in Fig. 5 with the triangle marking through it is the visible reflection of the glass substrate 40 alone in areas where the coating 41 is not present. The difference between these two lines is relevant, because it shows the difference in glass side visible reflection between: (a) areas of the glass substrate 40 where the CE coating is not present (i.e., in non-electrode and non-trace areas), and (b) areas of the glass substrate 40 where the CE coating is present (i.e., in electrode and trace

areas). Thus, the larger the difference between these two lines (the bottom two lines in the Fig. 5 graph), the more visible the electrodes and traces are to a viewer from the point of view on the finger side in Fig. 7. It can be seen in Fig. 5 that there is a significant gap (more than 2.0 difference in reflectance percentage) between these two lines around the visible wavelength 600 nm (including on both sides thereof), meaning that the electrodes and traces on a touch panel made of the CE material will be very visible which can render a touch panel or the like aesthetically non-pleasing.

**[0068]** In contrast, Fig. 6 is a percent visible transmission/reflectance vs. wavelength (nm) graph illustrating the visible transmission (CGN-TR or TR) and glass side visible reflection (CGN-BRA or BRA) of the Example 1 coating of Fig. 4(a) according to an example embodiment of this invention on a glass substrate, demonstrating that it is transparent to visible light and has glass side visible reflectance more closely matched to that of the glass substrate compared to the CE in Fig. 5. Fig. 6, like Fig. 5, also illustrates the visible transmission (Glass-TR) and visible reflectance (Glass-BRA) for the glass substrate alone in areas without the coating on it. The line plot with the “x” through it in Fig. 6 is the glass side visible reflection of the Example 1 coating 41 on the glass substrate 40, and the line plot in Fig. 6 with the triangular marking through it is the visible reflection of the glass substrate 40 alone without the coating 41 on it. The difference between these two lines is relevant, because it shows the difference in visible reflection (from the point of view of the finger in Fig. 7) between (a) areas of the glass substrate and touch panel where coating 41 is not present (i.e., in non-electrode and non-trace areas), and (b) areas of the glass substrate and touch panel where the coating 41 is present (i.e., in electrode and trace areas). Thus, the larger the

difference between these two lines (the bottom two lines in the Fig. 6 graph), the more visible the electrodes and traces are to a viewer. And the smaller the difference between these two lines (the bottom two lines in the Fig. 6 graph), the less visible the electrodes and traces are to a viewer. Comparing Figs. 5 and 6 to each other, it can be seen that in Fig. 6 that there is a much smaller gap (if any) between these two lines for the visible wavelengths from about 550 nm to about 650 nm compared to the larger gap for the CE in Fig. 5, meaning that the electrodes and traces on a touch panel made of the Example 1 material (Fig. 6) will be much less visible (compared to the CE material of Fig. 5) which renders the touch panel more aesthetically pleasing. In other words, compared to the CE, Example 1 more closely matches the glass side visible reflectance of the coating 41 on the glass substrate 40 to the visible reflection of the glass substrate 40 in areas where the coating is not present, and thus make the electrodes and traces of the touch panel less visible to users and therefore more aesthetically pleasing.

**[0069]** The table below shows optical differences between the Comparative Example (CE) and Example 1, where at 550 nm TR is visible transmission, RA is film side visible reflectance which is measured viewing the glass/coating combination from the coating side, and BRA is glass side visible reflectance which is measured viewing the glass/coating combination from the glass side. As will be recognized by one skilled in the art, a\* and b\* are color values measured with respect to transmissive color [a\*(TR) and b\*(TR)], and glass side reflective color [a\*(BRA) and b\*(BRA)].

Table 3: Comparative Example (CE) vs. Example 1 (Optical Parameters) [Ill. C 2 deg.]

Parameter	Comparative Example (CE) on glass	Example 1 on glass substrate (Fig. 4a	Glass substrate alone
-----------	-----------------------------------	---------------------------------------	-----------------------

	substrate	embodiment)	
TR(%)	88%	85.47%	91.7%
a* (TR)	-1	-0.60	-0.35
b* (TR)	1.5	1.05	0.18
BRA(%)	5.8%	8.20%	8.11%
a* (BRA)	-2.2	-2.37	-0.17
b* (BRA)	-6	-6.43	-0.74

**[0070]** The glass side visible reflection (BRA) of the coating 41 on the glass substrate 40 for Example 1 more closely matches the visible reflection of the glass substrate 40 alone (8.20% vs. 8.11%), compared to the CE (5.8% vs. 8.11%). Thus, the patterned coating 41 on the glass substrate 40 is much less visible for Example 1 compared to the CE.

**[0071]** In certain example embodiments of this invention (e.g., Figs. 2-7), the coating 41 (unlike the CE) on a glass substrate 40 has a film side visible reflectance (RA) from 550-600 nm of from 7-10%, more preferably from 7.5 to 8.5%. And in certain example embodiments of this invention, the coating 41 (unlike the CE) on a glass substrate 40 has a glass side visible reflectance (BRA) from 550-600 nm of from 7-13%, more preferably from 7-9%, and still more preferably from 7.25 to 8.75% (the BRA for the CE was only 5.8% as seen above). In certain example embodiments of this invention, unlike the CE, there is no more than a 2.0 difference (more preferably no more than a 1.5 or 1.0 difference) at 550 nm and/or 600 nm, or in the range from 550-600 nm, between: (a) the film side and/or glass side visible reflectance percentage of a coated article including the coating 41 on a glass substrate 40 (in the area where the coating 41 is present), and (b) the visible reflectance percentage of the glass substrate alone in areas

where coating 41 is not present. This can be seen in Fig. 6 for example (see also Figs. 8(a)-(b)). In contrast, for example, for the CE it can be seen from the above that there is a 2.31 difference ( $8.11\% - 5.8\% = 2.31$ ) between (a) the glass side visible reflectance percentage of a coated article including the CE coating on a glass substrate 40 in the area where the coating 41 is present, and (b) the visible reflectance percentage of the glass substrate alone, which is too much of a difference and renders the electrodes and traces easily visible to viewers viewing the device from the side of the finger shown in Fig. 7. Example embodiments of this invention have reduced this difference to no more than 2.0, more preferably no more than 1.5, and most preferably no more than 1.0.

**[0072]** While the Comparative Example (CE) is discussed above in connection with comparison to Example 1, it is noted that the coatings of both the CE and Example 1 may be used as the electrodes and/or traces in a touch panel according to example embodiments of this invention.

**[0073]** In certain example embodiments, an antireflective (AR) coating may be provided between the glass substrate 40 and the coating 41 of any of Figs. 4(a)-(g) to still more closely match the visible reflectance (glass side and/or film side) of the coating to that of the supporting substrate (glass plus AR coating). The AR coating may be applied across the entire or substantially the entire major surface of the glass substrate 40, and unlike the transparent conductive coating 41, the AR coating need not be patterned in certain example embodiments. As another optional, an AR coating may in effect be provided as a bottom portion of the coating 41 in order to add AR effect to the coating 41.

[0074] Fig. 4(b) illustrates a multilayer transparent conductive coating 41 according to another example embodiment which may be provided, either directly or indirectly, substrate 40 in any of the devices or products discussed herein (e.g., see Figs. 2-3, 7 and 9-17). Substrate 40 may be, for example, glass or glass coated with an AR coating. Coating 41 of the Fig. 4(b) embodiment may include, for example, base dielectric layer 61 or of including silicon nitride (e.g.,  $\text{Si}_3\text{N}_4$  or other suitable stoichiometry), which may or may not be doped with Al and/or oxygen; low index dielectric layer 62 of or including silicon oxide (e.g.,  $\text{SiO}_2$  or other suitable stoichiometry) which may or may not be doped with Al and/or nitrogen; a dielectric high index layer 43 of or including a material such as titanium oxide or niobium oxide, which may include titanium oxide (e.g.,  $\text{TiO}_2$  or other suitable stoichiometry); a dielectric layer 44 of or including zinc oxide (optionally doped with Al) or any of the other materials discussed herein in connection with layer 44, to be in contact with the silver-based layer; a silver-based conductive layer 46 on and directly contacting the zinc oxide based layer 44; an upper contact layer 47 including nickel and/or chromium which may be oxidized and/or nitrided, that is over and contacting the silver-based conductive layer 46; a dielectric high index layer 48 of or including a material such as titanium oxide or niobium oxide, which may include titanium oxide (e.g.,  $\text{TiO}_2$  or other suitable stoichiometry); a dielectric layer 49 of or including tin oxide (e.g.,  $\text{SnO}_2$ ); and an outermost protective dielectric layer 50 of or including silicon nitride and/or silicon oxynitride. Each of the layers in the coating 41 is designed to be substantially transparent (e.g., at least 70% or at least 80% transparent) to visible light. The silver layer 46 may or may not be doped with other materials as discussed herein.

**[0075]** The coatings 41 of Figs. 4(a)-(c) are designed to achieve good conductivity while at the same time to reduce visibility by more closely matching its visible reflectance (glass side and/or film side visible reflectance) to the visible reflectance of the supporting substrate 40. Substantial matching of the visible reflectance of the coating 41 and the visible reflectance of the supporting glass substrate 40 reduces visibility of the electrodes and traces formed of the coating material 41. While various thicknesses and materials may be used in layers in different embodiments of this invention, example thicknesses and materials for the respective sputter-deposited layers of coating 41 on the glass substrate 40 in the Fig. 4(b) embodiment are as follows, from the glass substrate outwardly:

Table 4: Fig. 4(b) Transparent Conductive Coating

Ref	Material	Preferred Thickness (Å)	More Preferred Thickness (Å)	Example Thickness (Å)
61	Si <sub>x</sub> N <sub>y</sub>	200-500	250-400	318
62	SiO <sub>x</sub>	200-600	400-500	440
43	TiO <sub>x</sub>	130-185	150-185	354
44	ZnO	50-140	60-100	83
46	Ag	90-160	115-140	124
47	NiCrO <sub>x</sub>	15-50	15-30	20
48	TiO <sub>x</sub>	10-60	15-35	23
49	SnO <sub>2</sub>	80-220	110-150	130
50	Si <sub>x</sub> N <sub>y</sub>	300-400	300-320	303

**[0076]** It is noted that the above materials for Fig. 4(b) coating 41 are exemplary, so that other material(s) may instead be used and certain layers may be omitted in certain example embodiments. This coating has both low sheet resistance, and has layers

designed to reduce visibility of the coating 41 on the supporting glass substrate 40. In certain exemplary embodiments, glass substrate 40 with coating 41 thereon may be heat treated (e.g., thermally tempered), e.g., after coating, or chemically strengthened before coating. As with the Fig. 4(a) embodiment, the silver-based coating 41 of the Fig. 4(b) embodiment is inexpensive, has a low sheet resistance (preferably less than 15 ohms/square, more preferably less than about 10 or 5 ohms/square, with an example being approximately 4 ohms per square) and maintains high visible transmittance (preferably at least 60%, more preferably at least 70%, more preferably at least 80%, and most preferably at least 84%). The coating 41 is preferably deposited on substantially the entirety of the major surface of the glass substrate 40, and then patterned to form the electrodes and/or traces discussed herein.

**[0077]** EXAMPLE 2 vs. COMPARATIVE EXAMPLE (CE)

**[0078]** Example 2 utilizes a coating according to the Fig. 4(b) embodiment.

Surprisingly and unexpectedly, it has been found that the Fig. 4(b) coating can surprisingly reduce the visibility of the coating 41 on the supporting substrate 40, and thus make the electrodes and traces of the touch panel less visible to users and therefore the overall panel more aesthetically pleasing compared to the CE discussed above. This is evidenced, for example, by the comparison below between a Comparative Example (CE) and Example 2 of this invention, where the coatings include from the glass substrate outwardly:

Table 5: Comparative Example (CE) vs. Example 2

Ref	Material	Example 2 Thickness (Å)

61	Si <sub>3</sub> N <sub>4</sub>	318
62	SiO <sub>2</sub>	440
43	TiO <sub>2</sub>	354
44	ZnO	83
46	Ag	124
47	NiCrO <sub>x</sub>	20
48	TiO <sub>2</sub>	23
49	SnO <sub>2</sub>	130
50	Si <sub>3</sub> N <sub>4</sub>	303

**[0079]** Fig. 5 is discussed above, and illustrates properties of the CE.

**[0080]** In contrast, Fig. 8(a) is a percent visible transmission/reflectance vs. wavelength (nm) graph illustrating the visible transmission (CGN-TR or TR) and glass side visible reflection (CGN-BRA or BRA) of Example 2 of this invention, demonstrating that it is transparent to visible light and has a glass side visible reflectance more closely matched to the reflectance of the glass substrate alone compared to the CE of Fig. 5. Fig. 8(a) also illustrates the visible transmission (Glass-TR) and visible reflectance (Glass-BRA) for just the glass substrate absent the coating. The line plot with the “x” through it in Fig. 8(a) is the glass side visible reflection of the Example 2 coating 41 on the glass substrate 40, and the line plot in Fig. 8(a) with the triangular marking through it is the visible reflection of the glass substrate 40 alone without the coating 41 on it. The difference between these two lines is significant, because it shows the difference in visible reflection (from the point of view of the finger in Fig. 7) between (a) areas of the glass substrate and touch panel where coating 41 is not present (i.e., in non-electrode and non-trace areas), and (b) areas of the glass substrate and touch panel where the coating 41 is present (i.e., in electrode and trace areas). Thus, the larger the

difference between these two lines (the bottom two lines in the Fig. 8(a) graph), the more visible the electrodes and traces are to a viewer. And the smaller the difference between these two lines (the bottom two lines in the Fig. 8(a) graph), the less visible the electrodes and traces are to a viewer. Comparing Figs. 5 and 8(a) to each other, it can be seen that in Fig. 8(a) that there is a much smaller gap (if any) between these two lines for the visible wavelengths from about 550 nm to about 650 nm compared to the larger gap for the CE in Fig. 5, meaning that the electrodes and traces on a touch panel made of the Example 2 material will be much less visible (compared to the CE material of Fig. 5) which renders the touch panel more aesthetically pleasing. In other words, compared to the CE, Example 2 more closely matches the glass side visible reflectance of the coating 41 on the glass substrate 40 to the visible reflection of the glass substrate 40 in areas where the coating is not present, and thus make the electrodes and traces of the touch panel less visible to users and therefore more aesthetically pleasing.

**[0081]** The table below shows optical differences between the Comparative Example (CE) and Example 2, where at 550 nm TR is visible transmission, RA is film side visible reflectance which is measured viewing the glass/coating combination from the coating side, and BRA is glass side visible reflectance which is measured viewing the glass/coating combination from the glass side. As will be recognized by one skilled in the art, a\* and b\* are color values measured with respect to transmissive color [a\*(TR) and b\*(TR)], and glass side reflective color [a\*(BRA) and b\*(BRA)].

Table 6: Comparative Example (CE) vs. Example 2 (Optical Parameters) [Ill. C 2 deg.]

Parameter	Comparative Example (CE) on glass	Example 2 on glass substrate (Fig. 4b)	Glass substrate alone
-----------	-----------------------------------	--	-----------------------

	substrate	embodiment)	
TR(%)	88%	85.75%	91.7%
a* (TR)	-1	-1.05	-0.35
b* (TR)	1.5	-0.31	0.18
BRA(%)	5.8%	7.86%	8.11%
a* (BRA)	-2.2	0.02	-0.17
b* (BRA)	-6	-0.33	-0.74

**[0082]** It is relevant here that the glass side visible reflection (BRA) of the coating 41 on the glass substrate 40 for Example 2 more closely matches the visible reflection of the glass substrate 40 alone (7.86% vs. 8.11%), compared to the CE (5.8% vs. 8.11%). Thus, the patterned coating 41 on the glass substrate 40 is much less visible for Example 2 compared to the CE. As discussed above, in certain example embodiments of this invention (e.g., Figs. 2-7), the coating 41 (unlike the CE) on a glass substrate 40 has a film side visible reflectance (RA) from 550-600 nm of from 7-10%, more preferably from 7.5 to 8.5%. And in certain example embodiments of this invention, the coating 41 (unlike the CE) on a glass substrate 40 has a glass side visible reflectance (BRA) from 550-600 nm of from 7-13%, more preferably from 7-9%, and still more preferably from 7.25 to 8.75% (the BRA for the CE was only 5.8% as seen above). As also mentioned above, in certain example embodiments of this invention there is no more than a 2.0 difference (more preferably no more than a 1.5 or 1.0 difference) at 550 nm and/or 600 nm, or in the range from 550-600 nm, between: (a) the film side and/or glass side visible reflectance percentage of a coated article including the coating 41 on a glass substrate 40 (in the area where the coating 41 is present), and (b) the visible reflectance percentage of the glass substrate alone in areas where coating 41 is

not present. This can be seen in Fig. 8(a) for example (see also Figs. 6 and 8(b)). In contrast, for example, for the CE it can be seen from the above that there is a 2.31 difference ( $8.11\% - 5.8\% = 2.31$ ) between (a) the glass side visible reflectance percentage of a coated article including the CE coating on a glass substrate 40 in the area where the coating 41 is present, and (b) the visible reflectance percentage of the glass substrate alone, which is too much of a difference and renders the electrodes and traces easily visible to viewers viewing the device from the side of the finger shown in Fig. 7.

Example embodiments of this invention have reduced this difference to no more than 2.0, more preferably no more than 1.5, and most preferably no more than 1.0.

**[0083]** Fig. 4(c) illustrates a multilayer transparent conductive coating (41' or 41", both of which may also be referred to as 41) according to another example embodiment which may be provided, either directly or indirectly, substrate 40 in any of the devices or products discussed herein (e.g., see Figs. 2-3, 7 and 9-17). Substrate 40 may be, for example, glass. Coating 41' of the Fig. 4(c) embodiment may include, for example, an antireflective (AR) section 70 including a dielectric high index layer 71 of or including a material such as titanium oxide or niobium oxide, which may include titanium oxide (e.g.,  $\text{TiO}_2$  or other suitable stoichiometry); low index dielectric layer 72 of or including silicon oxide (e.g.,  $\text{SiO}_2$  or other suitable stoichiometry) which may or may not be doped with Al and/or nitrogen; a dielectric high index layer 73 of or including a material such as titanium oxide or niobium oxide; another low index dielectric layer 74 of or including silicon oxide (e.g.,  $\text{SiO}_2$  or other suitable stoichiometry) which may or may not be doped with Al and/or nitrogen, and a dielectric layer 75 of or including zirconium oxide (e.g.,  $\text{ZrO}_2$  or other suitable stoichiometry). The "substrate" in the Fig.

4(c) embodiment may be considered the glass 40 plus the AR section 70 of the coating, as the AR section 70 of the coating 41' need not be patterned along with the rest of the coating 41', and in such a case the transparent conductive coating of the Fig. 4(c) embodiment may be considered to be made up of just the layers 61, 44, 46, 47 and 50. In other words, in the Fig. 4(c) embodiment, the multi-layer transparent conductive coating may be considered as 41" which is made up of layers 61, 44, 46, 47 and 50, and the "substrate" may be considered to be the combination of the glass 40 and the AR coating 70.

**[0084]** The coating 41 of the Fig. 4(c) embodiment may further include, as section 41", dielectric layer 61 or of including silicon nitride (e.g.,  $\text{Si}_3\text{N}_4$  or other suitable stoichiometry), which may or may not be doped with Al and/or oxygen; a dielectric layer 44 of or including zinc oxide (optionally doped with Al) or any of the other materials discussed herein in connection with layer 44, to be in contact with the silver-based layer; a silver-based conductive layer 46 on and directly contacting the zinc oxide based layer 44; an upper contact layer 47 including nickel and/or chromium which may be oxidized and/or nitrated, that is over and contacting the silver-based conductive layer 46; optionally a dielectric high index layer 48 of or including a material such as titanium oxide or niobium oxide, which may include titanium oxide (e.g.,  $\text{TiO}_2$  or other suitable stoichiometry); and an outer-most protective dielectric layer 50 of or including silicon nitride and/or silicon oxynitride. Each of the layers in the coating 41 of the Fig. 4(a)-(c) embodiments is designed to be substantially transparent (e.g., at least 70% or at least 80% transparent) to visible light. Silver layer 46 may or may not be doped as discussed herein.

**[0085]** The coating 41 of Fig. 4(c) is designed to achieve good conductivity while at the same time to reduce visibility by more closely matching its visible reflectance (glass side and/or film side visible reflectance) to the visible reflectance of the supporting substrate. Substantial matching of the visible reflectance of the coating 41 and the visible reflectance of the supporting substrate reduces visibility of the electrodes and traces formed of the coating material 41. While various thicknesses and materials may be used in layers in different embodiments of this invention, example thicknesses and materials for the respective sputter-deposited layers of coating 41 on the glass 40 in the Fig. 4(c) embodiment are as follows, from the glass outwardly:

Table 7: Fig. 4(c) Coating

Ref	Material	Preferred Thickness (Å)	More Preferred Thickness (Å)	Example Thickness (Å)
71	TiO <sub>x</sub>	40-350	50-250	100
72	SiO <sub>x</sub>	200-600	300-450	373
73	NbO <sub>x</sub>	200-2000	500-1500	1112
74	SiO <sub>x</sub>	200-1200	500-950	744
75	ZrO <sub>x</sub>	30-120	30-80	50
61	Si <sub>x</sub> N <sub>y</sub>	150-500	200-400	271
44	ZnO	50-140	60-100	83
46	Ag	90-160	115-150	131
47	NiCrO <sub>x</sub>	15-50	15-30	20
50	Si <sub>x</sub> N <sub>y</sub>	300-450	300-350	339

**[0086]** It is noted that the above materials for Fig. 4(c) coating 41 are exemplary, so that other material(s) may instead be used and certain layers may be omitted in certain example embodiments. The coating has both low sheet resistance, and has layers

designed to reduce visibility of the coating 41 on the supporting substrate. In certain exemplary embodiments, glass substrate 40 with coating 41 thereon may be heat treated (e.g., thermally tempered), e.g., after coating, or chemically strengthened before coating. As with the Fig. 4(a)-(b) embodiments, the silver-based coating 41 of the Fig. 4(c) embodiment is inexpensive, has a low sheet resistance (preferably less than 15 ohms/square, more preferably less than about 10 or 5 ohms/square, with an example being approximately 4 ohms per square) and maintains high visible transmittance (preferably at least 60%, more preferably at least 70%, more preferably at least 80%, and most preferably at least 84%). The coating 41 is preferably deposited on substantially the entirety of the major surface of the glass substrate 40 and then patterned to form the electrodes and traces discussed herein.

**[0087]** EXAMPLE 3 vs. COMPARATIVE EXAMPLE (CE)

**[0088]** Example 3 utilizes a coating according to the Fig. 4(c) embodiment.

Surprisingly and unexpectedly, it has been found that the Fig. 4(c) coating can surprisingly reduce the visibility of the coating 41 on the supporting substrate, and thus make the electrodes and traces of the touch panel less visible to users and therefore the overall panel more aesthetically pleasing compared to the CE discussed above. This is evidenced, for example, by the comparison below between a Comparative Example (CE) and Example 3 of this invention, where the coatings include from the glass outwardly:

Table 8: Comparative Example (CE) vs. Example 3

Ref	Material	Example 3 Thickness (Å)
71	TiO <sub>2</sub>	100

72	SiO <sub>2</sub>	373
73	NbO <sub>x</sub>	1112
74	SiO <sub>2</sub>	744
75	ZrO <sub>2</sub>	50
61	Si <sub>3</sub> N <sub>4</sub>	271
44	ZnO	83
46	Ag	131
47	NiCrO <sub>x</sub>	20
50	Si <sub>3</sub> N <sub>4</sub>	339

**[0089]** Fig. 5 is discussed above, and illustrates properties of the CE.

**[0090]** In contrast, Fig. 8(b) is a percent visible transmission/reflectance vs. wavelength (nm) graph illustrating the visible transmission (CGN-TR or TR) and glass side visible reflection (CGN-BRA or BRA) of Example 3 according to another example embodiment of this invention, demonstrating that it is transparent to visible light and has a glass side visible reflectance more closely matched to the reflectance of the substrate compared to the CE. Fig. 8(b) also illustrates the visible transmission (Glass-TR) and visible reflectance (Glass-BRA) for just the glass substrate and AR section 71-75 absent the other layers (61, 44, 46, 47 and 50) of the coating. The line plot with the “x” through it in Fig. 8(b) is the glass side visible reflection of the Example 3 coating 41 on the glass substrate 40, and the line plot in Fig. 8(b) with the triangular marking through it is the visible reflection of the glass substrate 40 with only the AR section 70-75 thereon. The difference between these two lines is relevant, because it shows the difference in visible reflection (from the point of view of the finger in Fig. 7) between (a) areas of the glass substrate and touch panel where just the AR section of the coating is present (i.e., in non-electrode and non-trace areas), and (b) areas of the glass substrate and touch panel where

the entire coating 41 is present (i.e., in electrode and trace areas). Thus, the larger the difference between these two lines (the bottom two lines in the Fig. 8(b) graph), the more visible the electrodes and traces are to a viewer. And the smaller the difference between these two lines (the bottom two lines in the Fig. 8(b) graph), the less visible the electrodes and traces are to a viewer. Comparing Figs. 5 and 8(b) to each other, it can be seen that in Fig. 8(b) that there is a much smaller gap (if any) between these two lines for the visible wavelengths from about 550 nm to about 650 nm compared to the larger gap for the CE in Fig. 5, meaning that the electrodes and traces on a touch panel made of the Example 3 material will be much less visible (compared to the CE material of Fig. 5) which renders the touch panel more aesthetically pleasing. In other words, compared to the CE, Example 3 more closely matches the glass side visible reflectance of the coating 41 on the glass substrate 40 to the visible reflection of the supporting substrate (glass plus AR layers), and thus make the electrodes and traces of the touch panel less visible to users and therefore more aesthetically pleasing.

**[0091]** The table below shows optical characteristics of Example 3, where at 550 nm TR is visible transmission, RA is film side visible reflectance which is measured viewing the glass/coating combination from the coating side, and BRA is glass side visible reflectance which is measured viewing the glass/coating combination from the glass side. As will be recognized by one skilled in the art,  $a^*$  and  $b^*$  are color values measured with respect to transmissive color [ $a^*(TR)$  and  $b^*(TR)$ ], and glass side reflective color [ $a^*(BRA)$  and  $b^*(BRA)$ ]. In the table below for Example 3, the glass substrate parameters are for the glass substrate with only AR layers 71-75 thereon across the entire substrate 40, and the Example 3 parameters are for the entire coating 41 on the

glass substrate 40 (i.e., the AR layers 71-75 may be provided across substantially the entire substrate whereas the layers 61, 44, 46, 47 and 50 may be patterned to form the electrodes and traces).

Table 9: Example 3 (Optical Parameters) [Ill. C 2 deg.]

Parameter	Example 3 on glass substrate (Fig. 4c embodiment)	Glass substrate with only AR layers 71-75 thereon
TR(%)	85.61%	94.80%
a* (TR)	-0.78	-0.30
b* (TR)	-0.94	0.35
BRA(%)	4.99%	4.51%
a* (BRA)	-0.15	-0.44
b* (BRA)	-1.38	-2.34

**[0092]** The glass side visible reflection (BRA) of the entire coating 41 on the glass substrate 40 for Example 3 closely matches the visible reflection of the glass substrate 40 with only the AR layers 71-75 thereon (4.99% vs. 4.51%). Thus, the patterned coating portion (61, 44, 46, 47 and 50) on the substrate is much less visible for Example 3 compared to the CE. In certain example embodiments of this invention, the coating 41 (unlike the CE) of this embodiment on a glass substrate 40 has a glass side visible reflectance (BRA) from 550-600 nm of from 4-13%, more preferably from 4.5-9%, and still more preferably from 4.5 to 8.75%. As also mentioned above, in certain example embodiments of this invention (Figs. 2-14) there is no more than a 2.0 difference (more preferably no more than a 1.5 or 1.0 difference) at 550 nm and/or 600 nm, or in the range from 550-600 nm, between: (a) the film side and/or glass side visible reflectance

percentage of a coated article including the entire coating 41 on a glass substrate 40 (in the area where the coating 41 is entirely present), and (b) the visible reflectance percentage of the glass substrate areas where only the glass 40 and AR layers 71-75 are present. This can be seen in Fig. 8(b) for example. In contrast, for example, for the CE it can be seen from the above that there is a 2.31 difference ( $8.11\% - 5.8\% = 2.31$ ) between (a) the glass side visible reflectance percentage of a coated article including the CE coating on a glass substrate 40 in the area where the coating 41 is present, and (b) the visible reflectance percentage of the glass substrate alone, which is too much of a difference and renders the electrodes and traces easily visible to viewers viewing the device from the side of the finger shown in Fig. 7. Example embodiments of this invention have reduced this difference to no more than 2.0, more preferably no more than 1.5, and most preferably no more than 1.0.

**[0093]** Fig. 4(d) illustrates a multilayer transparent conductive coating 41 according to another example embodiment which may be provided, either directly or indirectly, on substrate 40 in any of the devices or products discussed herein (e.g., see Figs. 2-3, 7 and 9-17). Substrate 40 may be, for example, glass or glass coated with an AR coating. Coating 41 of the Fig. 4(d) embodiment may include, for example, base dielectric layer 61 or of including silicon nitride (e.g.,  $\text{Si}_3\text{N}_4$  or other suitable stoichiometry) which may or may not be doped with Al and/or oxygen, silicon oxynitride, or other suitable dielectric material; lower contact layer 44 of or including zinc oxide which may be doped with from about 1-8% Al, or may be of or include any of the other materials discussed herein in connection with layer 44, and is in contact with the silver based layer; silver-based conductive layer 46 on and directly contacting the lower

contact layer 44; an upper contact layer 47 including nickel and/or chromium which may be oxidized and/or nitrided that is over and contacting the silver-based conductive layer 46; dielectric layer 50 of or including silicon nitride and/or silicon oxynitride or other suitable material, dielectric layer of or including zirconium oxide (e.g.,  $ZrO_2$ ) 75, and optionally protective layer of or including diamond-like carbon (DLC) 120. The DLC of layer 120 may, for example, be any of the DLC materials discussed in any of U.S. Patent Nos. 6,261,693, 6,303,225, 6,447,891, 7,622,161, and/or 8,277,946, which are incorporated herein by reference. Each of the layers in the coating 41 is designed to be substantially transparent (e.g., at least 70% or at least 80% transparent) to visible light. The silver layer 46 may or may not be doped with other materials as discussed herein. Upper contact layer 47 may be of or include materials such as NiCr, NiCrO<sub>x</sub>, NiCrN<sub>x</sub>, NiCrON<sub>x</sub>, NiCrMo, NiCrMoO<sub>x</sub>, TiO<sub>x</sub>, or the like.

**[0094]** While various thicknesses and materials may be used in layers in different embodiments of this invention, example thicknesses and materials for the respective sputter-deposited layers of coating 41 on the glass 40 in the Fig. 4(d) embodiment are as follows, from the glass outwardly:

Fig. 4(d) Coating

Ref	Material	Preferred Thickness (Å)	More Preferred Thickness (Å)	Example Thickness (Å)
61	Si <sub>x</sub> N <sub>y</sub>	150-500	200-400	271
44	ZnO	50-140	60-100	83
46	Ag	90-160	115-150	131
47	NiCrN <sub>x</sub>	15-50	15-30	20
50	Si <sub>x</sub> N <sub>y</sub>	200-500	300-350	339
75	ZrO <sub>2</sub>	40-300	50-200	100

120	DLC	10-200	20-150	40-120
-----	-----	--------	--------	--------

**[0095]** Fig. 4(e) illustrates a multilayer transparent conductive coating 41 according to another example embodiment which may be provided, either directly or indirectly, on substrate 40 in any of the devices or products discussed herein (e.g., see Figs. 2-3, 7 and 9-17). The Fig. 4(e) coating is the same as the Fig. 4(d) coating, except that layer 120 is not present in the Fig. 4(e) coating.

**[0096]** Fig. 4(f) illustrates a multilayer transparent conductive coating 41 according to another example embodiment which may be provided, either directly or indirectly, on substrate 40 in any of the devices or products discussed herein (e.g., see Figs. 2-3, 7 and 9-17). Substrate 40 may be, for example, glass or glass coated with an AR coating. Coating 41 of the Fig. 4(f) embodiment may include, for example, base dielectric layer 61 or of including silicon nitride (e.g.,  $\text{Si}_3\text{N}_4$  or other suitable stoichiometry), which may or may not be doped with Al and/or oxygen; lower contact layer 101 in contact with the silver based layer and which may include nickel and/or chromium which may be oxidized and/or nitrided; silver-based conductive layer 46 on and directly contacting the lower contact layer 101; an upper contact layer 47 including nickel and/or chromium which may be oxidized and/or nitrided that is over and contacting the silver-based conductive layer 46; and an protective dielectric layer 50 of or including silicon nitride and/or silicon oxynitride. Each of the layers in the coating 41 is designed to be substantially transparent (e.g., at least 70% or at least 80% transparent) to visible light. The silver layer 46 may or may not be doped as discussed herein. Upper and lower contact layers 47 and 101 may be of or include materials such as NiCr, NiCrO<sub>x</sub>, NiCrN<sub>x</sub>, NiCrON<sub>x</sub>, NiCrMo, NiCrMoO<sub>x</sub>, TiO<sub>x</sub>, or the like. Optionally, a layer of or including

diamond-like carbon (DLC) or zirconium oxide (e.g.,  $ZrO_2$ ) may be provided as a protective overcoat in the coating 41 over the layer 50 in the Fig. 4(f) embodiment. The zirconium oxide and/or DLC layers discussed herein provide for scratch resistance, and resistance to stains and cleaning chemicals in applications such as shower door/wall touch panel applications. The use of one or more of NiCr,  $NiCrO_x$ ,  $NiCrN_x$ ,  $NiCrON_x$ , NiCrMo, and/or  $MiCrMoO$  for layer lower contact layer 101, instead of crystalline zinc oxide layer 44, allows the conductivity of the silver layer 46 to be reduced in a manner that is sometimes desirable, as discussed herein.

**[0097]** While various thicknesses and materials may be used in layers in different embodiments of this invention, example thicknesses and materials for the respective sputter-deposited layers of coating 41 on the glass 40 in the Fig. 4(f) embodiment are as follows, from the glass outwardly:

Fig. 4(f) Coating

Ref	Material	Preferred Thickness (Å)	More Preferred Thickness (Å)	Example Thickness (Å)
61	$Si_xN_y$	10-500	20-200	100
101	$NiCrN_x$	5-50	10-30	20
46	Ag	50-160	115-150	131
47	$NiCrN_x$	5-50	10-30	20
50	$Si_xN_y$	100-500	200-300	250

**[0098]** Fig. 4(g) illustrates a multilayer transparent conductive coating 41 according to another example embodiment which may be provided, either directly or indirectly, on substrate 40 in any of the devices or products discussed herein (e.g., see Figs. 2-3, 7 and 9-17). Substrate 40 may be, for example, glass or glass coated with an AR coating. Coating 41 of the Fig. 4(g) embodiment may include, for example, base

dielectric layer 61 or of including silicon nitride (e.g.,  $\text{Si}_3\text{N}_4$  or other suitable stoichiometry), which may or may not be doped with Al and/or oxygen; lower contact layer 44 as discussed above in connection with other figures; silver-based conductive layer 46 on and directly contacting the lower contact layer 44; an upper contact layer 47 including nickel and/or chromium which may be oxidized and/or nitrated that is over and contacting the silver-based conductive layer 46; dielectric layer 50 of or including silicon nitride and/or silicon oxynitride, which may be doped with from about 1-8% (atomic %) Al; and protective overcoat of or including zirconium oxide (e.g.,  $\text{ZrO}_2$ ) 75. Each of the layers in the coating 41 is designed to be substantially transparent (e.g., at least 70% or at least 80% transparent) to visible light. The silver layer 46 may or may not be doped with other materials as discussed herein. Upper contact layer 47 may be of or include materials such as NiCr,  $\text{NiCrO}_x$ ,  $\text{NiCrN}_x$ ,  $\text{NiCrON}_x$ ,  $\text{NiCrMo}$ ,  $\text{NiCrMoO}_x$ ,  $\text{TiO}_x$ , or the like. Optionally, a layer of or including diamond-like carbon (DLC) may be provided as a protective overcoat in the coating 41 over the layer 75 in the Fig. 4(g) embodiment. Note that layer 47 may optionally be omitted from the Fig. 4(g) embodiment in certain example embodiments of this invention.

**[0099]** While various thicknesses and materials may be used in layers in different embodiments of this invention, example thicknesses and materials for the respective sputter-deposited layers of coating 41 on the glass 40 in the Fig. 4(g) embodiment are as follows, from the glass outwardly:

Fig. 4(g) Coating

Ref	Material	Preferred Thickness (Å)	More Preferred Thickness (Å)	Example Thickness (Å)
61	$\text{Si}_x\text{N}_y$	10-500	20-200	100

44	ZnO	20-140	30-100	83
46	Ag	50-160	115-150	131
47	NiCrNx	5-50	10-30	20
50	Si <sub>x</sub> N <sub>y</sub>	100-500	200-300	250
75	ZrO <sub>2</sub>	40-300	50-200	100

**[00100]** The coatings shown in any of Figs. 4-6 of parent case 13/685,871 (now U.S. Patent No. 9,354,755, and incorporated herein by reference), and/or described elsewhere in parent case 13/685,871, may also be used as the multi-layer transparent conductive coatings 41 in touch panels for electrodes and/or traces in any of the various embodiments discussed herein.

**[00101]** The patterned low sheet resistance coatings 41 herein (e.g., any of the Fig. 2-8 embodiments) may also be used in low resolution touch panel applications (e.g., see Fig. 9). Example applications for touch panels discussed herein are interactive storefronts, preferably standalone, but possibly also in combination with a projected image on the glass assembly or with direct view displays, shower controls on glass based shower doors or glass based shower walls, light controls on glass walls in office buildings, controls for appliances such as ovens, stovetops, refrigerators, and the like. The glass substrate 40 may be flat or curved (e.g., heat bent) in different embodiments of this invention. The silver based coatings 41 discussed herein are advantageous with respect to bent substrates, because conventional ITO coatings for touch panels are typically highly crystalline and relatively thick and brittle when bent, which can readily lead to failure of the ITO. In bent glass applications, the glass or plastic substrate 40 may be bent for example via heat bending, cold lamination, or any other suitable technique, and may end up with a curvature radius after bending of from about 0.05 to 100 nm. Low

resolution touch panels on glass allow the user to select information or otherwise interact with the glass surface while simultaneously viewing what's behind the glass. In a standalone configuration, for example, the touch panel may be operated from both sides of the glass panel. Low resolution capacitive touch panels may be for example an array of 5 x 5 touch buttons, each about a square inch and separated by about half an inch, as shown in Fig. 9. The touch principle of operation may be self-capacitance which can detect gloved fingers as well as bare fingers. The interconnect flex circuit in Fig. 9 is connected to a touch controller and the function of each button can therefore be reconfigured in software or firmware. The lower resolution touch interface is easier to make than a multi-touch panel on top of a high resolution LCD, because the minimum feature size for the patterning coating 41 by laser, photolithography or other method can be much larger. For example, the minimum feature size for the traces could be about 1 mm, so that the requirements for pinholes, scratches and other defects in the glass and in the coating are greatly relaxed. In other words, it allows the use of standard soda lime glass 40 and coatings 41 produced in a horizontal architectural coater. For certain low resolution touch applications, there is no need for the advanced clean room facilities that typically are used to produce high resolution multi-touch panels for phones, tablets, laptops and larger size multi-touch panels. The wider traces (e.g ~ 1 mm) also reduce the resistance and signal delay from the touch electrodes.

**[00102]** Referring to the laminated Fig. 10 embodiment (the coatings of any of Figs. 2-8 may be used in the Fig. 10 embodiment, as well as in the Fig. 7 lamination embodiment), to further protect the patterned silver based coating 41 from corrosion in a standalone application, the touch panel substrate 40 (with or without an AR coating

thereon between 40 and 41) is laminated to another glass substrate 45 with PVB, EVA, or other polymer inclusive lamination material 52. The PVB 52 based laminating layer for example will encapsulate the patterned coating 41, so that corrosion is further inhibited. Of course, as explained herein, the touch panel need not include the second substrates or the laminating layer in certain instances and may be made up of the glass substrate 40 and the electrodes/traces/circuitry discussed herein.

**[00103]** Figs. 15-17 are cross sectional views of capacitive touch panels according to various embodiments of this invention that include additional functional film 300. Fig. 15 is a cross sectional view of a capacitive touch panel according to an example embodiment of this invention, including the transparent conductive coating pattern 41 according to any of Figs. 2, 3, 4 (any of 4(a)-(g)), 7, 8, 9, or 10 on surface #2, and an additional functional film 300 provided on the surface adapted to be touched by a user. Note the user's finger shown in Fig. 15. Meanwhile, Fig. 16 is a cross sectional view of a capacitive touch panel according to another example embodiment of this invention, including the transparent conductive coating pattern 41 according to any of Figs. 2, 3, 4, 7, 8, 9, or 10 on surface #3, and an additional functional film 300 provided on the surface adapted to be touched by a user. In the laminated embodiments of Figs. 15-16, to further protect the patterned silver based coating 41 from corrosion, the touch panel substrate 40 (glass or plastic, with or without an AR coating thereon between 40 and 41) is laminated to another glass substrate 45 (or 200) with PVB or other polymer inclusive lamination material 52. The laminating material (e.g., EVA or PVB) 52 will encapsulate the patterned coating 41, so that corrosion is further inhibited. And Fig. 17 is a cross sectional view of a monolithic capacitive touch panel according to another example

embodiment of this invention, including the transparent conductive coating pattern 41 according to any of Figs. 2, 3, 4, 7, 8, 9, or 10 on surface #2, and additional functional films 300 and 301. The Fig. 17 monolithic embodiment may be designed for the user to touch either major surface of the touch panel. An interconnect 400, such as a flexible circuit, is provided for allowing the electrodes 41 of the touch panel to communicate with processing circuitry such as the processor discussed above.

**[00104]** Functional film 300 and/or 301 in Figs. 15-17 may be made up of one or more layers, and may be one or more of: an index-matching film, an antiglare film, an anti-fingerprint film, and anti-microbial film, a scratch resistant film, and/or an antireflective (AR) film. Unlike the electrode/trace coating 41, functional films 300 and 301 need not be patterned and may be applied across substantially the entirety of the substrate 40 (or 45).

**[00105]** When functional film 300 and/or 301 is an index matching (see also index matching film 85 in Fig. 7), this is provided to reduce the refractive index different between the areas/surfaces adjacent the two sides of the index matching film, in order to reduce visible reflections and render the touch panel more aesthetically pleasing. Laminating layers 52 in Figs. 15-16 may also be index matching films. Index matching films may or may not be adhesive types in different embodiments of this invention. Thus, the index matching film has a refractive index value that is valued between the respective refractive index values of the areas/surfaces on both sides of the index matching film. For example, in Fig. 7 the index matching film 85 has a refractive index value between the refractive index values of coating 41 and substrate 200. In a similar manner, in Fig. 15 the index matching film 300 would have a refractive index value

between the refractive index values of substrate 40 and air. In a similar manner, in Fig. 17 the index matching film 301 would have a refractive index value between the refractive index values of coating 41 and air. Example index matching films include optically clear adhesives and index matching laminating material.

**[00106]** When functional film 300 in Figs. 15-17 is an antiglare film, this is provided to reduce glare off the front of the touch panel in order to render the touch panel more aesthetically pleasing. Example anti-glare films that may be used are described in U.S. Patent Nos. 8,114,472 and 8,974,066, which are incorporated herein by reference. Moreover, an antiglare surface at surface #1 of the touch panel may be obtained by a short or weak acid etch of surface #1 (the surface shown being touched in Figs. 15-17).

**[00107]** When functional film 300 in Figs. 15-17 is an anti-fingerprint film, this is provided to reduce visibility of fingerprints on the touch panel to render the touch panel more aesthetically pleasing. Example anti-fingerprint films that may be used are described in U.S. Patent No. 8,968,831, which is incorporated herein by reference. Anti-fingerprint or anti-smudge films may be obtained for example with an oleo-phobic coating and/or roughened surface. Spray-on anti-fingerprint coatings, such as fluorocarbon compounds, with limited durability, may also be used. Such film may increase the initial contact angle of surface #1 (for sessile drop of water) of the touch panel to a value of at least 90 degrees, more preferably at least 100 degrees, and most preferably at least 110 degrees.

**[00108]** When functional film 300 in Figs. 15-17 is an anti-microbial film, this is provided to kill germs at the front of the touch panel in order to render the touch panel more health appealing. Example anti-microbial films that may be used include silver

colloids, rough titanium oxide, porous titanium oxide, doped titanium oxide, and may be described in U.S. Patent Document Nos. 8,647,652, 8,545,899, 7,846,866, 8,802,589, 2010/0062032, 7,892,662, 8,092,912, and 8,221,833, which are all incorporated herein by reference.

**[00109]** When functional film 300 in Figs. 15-17 is a scratch resistant film, this is provided to reduce scratching and improve durability of the touch panel. Example scratch resistant films may be made of ZrO<sub>2</sub> or DLC. When functional film 300 is of or includes DLC, the DLC may for example be any of the DLC materials discussed in any of U.S. Patent Nos. 6,261,693, 6,303,225, 6,447,891, 7,622,161, and/or 8,277,946, which are incorporated herein by reference.

**[00110]** When functional film 300 in Figs. 15-17 is an antireflective (AR) film, this is provided to reduce visible reflections off the front of the touch panel to render the panel more aesthetically pleasing. Example AR films that may be used are described in U.S. Patent Nos. 9,556,066, 9,109,121, 8,693,097, 7,767,253, 6,337,124, and 5,891,556, the disclosures of which are hereby incorporated herein by reference. In certain example embodiments, the AR film may be part of the multi-layer transparent conductive coating (e.g., see AR film 70 which is part of coating 41' in Fig. 4(c)).

**[00111]** It is noted that in various embodiments of this invention, electrode patterns other than a rectangular array of buttons can be envisioned including patterns allowing swiping, circular patterns for dials, and so forth. Potential applications include storefronts, commercial refrigerators, appliances, glass walls in office or other environments, transportation, dynamic glazing, vending machines, and so forth, where a see-through low resolution touch panel is beneficial as a user interface.

**[00112]** The sputter-deposited coating 41 discussed above in connection with Figs. 2-10 may be formed and patterned in any of a variety of manners. For example, the sputter-deposited coating 41 may be formed by inkjet printing and lift-off (see Fig. 11), metal shadow mask patterning (see Fig. 12), photolithograph (see Fig. 13), or laser patterning (see Fig. 14).

**[00113]** In an example embodiment of this invention, there is provided a capacitive touch panel, comprising: a glass substrate; a patterned multi-layer transparent conductive coating supported by the glass substrate, the multi-layer transparent conductive coating including at least one conductive layer comprising silver, a dielectric layer located between at least the glass substrate and the conductive layer comprising silver, and a dielectric layer which may optionally comprise one or more of: zirconium oxide, silicon nitride, and tin oxide located over the conductive layer comprising silver; a plurality of electrodes configured for allowing touch position to be determined, wherein at least some of the electrodes comprise the multi-layer transparent conductive coating; and a processor configured for determining touch position on the touch panel; wherein the processor is in electrical communication with at least some of the electrodes, for determining touch position on the touch panel; and wherein the plurality of electrodes are supported by the glass substrate.

**[00114]** In the capacitive touch panel of the immediately preceding paragraph, the plurality of electrodes may comprise transmit electrodes and receive electrodes, wherein the transmit electrodes may have a higher sheet resistance ( $R_s$ ) than do the receive electrodes, and wherein the transmit electrodes may have a sheet resistance ( $R_s$ ) at least 1 ohm/square higher than a sheet resistance of the receive electrodes.

**[00115]** In the capacitive touch panel of any of the preceding two paragraphs, the transmit electrodes may have a sheet resistance ( $R_s$ ) at least 5 ohms/square higher than a sheet resistance of the receive electrodes, more preferably at least 10 ohms/square higher, and most preferably at least 15 ohms/square higher.

**[00116]** In the capacitive touch panel of any of the preceding three paragraphs, the transmit electrodes may have a sheet resistance of from about 15-50 ohms/square (more preferably from about 20-50 ohms/square, and most preferably from about 20-40 ohms/square), and the receive electrodes may have a sheet resistance of from about 1-14 ohms/square (more preferably from about 2-12 ohms/square, and most preferably from about 2-10 ohms/square).

**[00117]** In the capacitive touch panel of any of the preceding four paragraphs, the transmit electrodes may comprise the patterned multi-layer transparent conductive coating, and wherein the conductive layer comprising silver of the transmit electrodes may be is doped. The conductive layer comprising silver may be doped with from about 0.05 to 3.0% (wt.%) of one or more of Zn, Pt, Pd, Ti, and Al, more preferably may be doped with from about 0.1 to 2.0% (wt.%) of one or more of Zn, Pt, Pd, Ti, and Al, and most preferably may be doped with from about 0.1 to 0.5% (wt.%) of one or more of Zn, Pt, Pd, Ti, and Al.

**[00118]** In the capacitive touch panel of any of the preceding five paragraphs, the layer over and contacting the conductive layer comprising silver may comprise Ni and/or Cr, optionally including Mo.

**[00119]** In the capacitive touch panel of any of the preceding six paragraphs, the transparent conductive coating may have a sheet resistance of less than or equal to about 40 ohms/square.

**[00120]** In the capacitive touch panel of any of the preceding seven paragraphs, the dielectric layer comprising one or more of zirconium oxide, silicon nitride, and tin oxide, may comprise silicon nitride, optionally further including oxygen and/or aluminum for example.

**[00121]** In the capacitive touch panel of any of the preceding eight paragraphs, the dielectric layer located between at least the glass substrate and the conductive layer comprising silver may comprise an oxide of titanium (e.g.,  $\text{TiO}_2$ ) or silicon nitride (e.g.,  $\text{Si}_3\text{N}_4$ ).

**[00122]** In the capacitive touch panel of any of the preceding eight paragraphs, the transmit electrodes may comprise the patterned multi-layer transparent conductive coating, and the multi-layer transparent conductive coating may further comprise a layer comprising Ni and Cr (optionally further including Mo) that contacts the layer comprising silver, wherein the layer comprising Ni and Cr is located between at least the glass substrate and the conductive layer comprising silver. Instead of the layer comprising an alloy such as NiCr or NiCrMo, this layer directly under and contacting the silver based layer may instead be a semiconductor layer (e.g., a-Si) or a substantially amorphous dielectric layer comprising one or more of silicon oxide, silicon nitride, silicon oxynitride, and titanium oxide.

**[00123]** In the capacitive touch panel of any of the preceding nine paragraphs, the transmit electrodes and the receive electrodes may each comprise the patterned multi-

layer transparent conductive coating, wherein the conductive layer comprising silver may be a conductor of the transmit electrodes and a second conductive layer comprising silver in the transparent conductive coating may be a conductor of the receive electrodes.

Alternatively, in the capacitive touch panel of any of the preceding nine paragraphs, the transmit electrodes may comprise the patterned multi-layer transparent conductive coating, and the receive electrodes may comprise another patterned multi-layer transparent conductive coating, wherein the another patterned multi-layer transparent conductive coating may comprise one or more of at least one conductive layer comprising silver, a dielectric layer located between at least the glass substrate and the conductive layer comprising silver, and a dielectric layer comprising one or more of: zirconium oxide, silicon nitride, and tin oxide located over the conductive layer comprising silver.

**[00124]** In the capacitive touch panel of any of the preceding ten paragraphs, the transmit electrodes and receive electrodes may be substantially parallel to each other.

**[00125]** In the capacitive touch panel of any of the preceding eleven paragraphs, the transmit electrodes and receive electrodes may (or may not) be coplanar.

**[00126]** In the capacitive touch panel of any of the preceding twelve paragraphs, the touch panel may be provided on a glass door, such as a shower door.

**[00127]** In the capacitive touch panel of any of the preceding thirteen paragraphs, the touch panel may be configured to control a shower functionality.

**[00128]** In the capacitive touch panel of any of the preceding fourteen paragraphs, the glass substrate may be thermally tempered.

**[00129]** In the capacitive touch panel of any of the preceding fifteen paragraphs, the glass substrate may further support a functional film, such as one or more of an antiglare film, an anti-microbial film, and an anti-fingerprint film. The functional film need not be patterned. The functional film may be located on an opposite side of the glass substrate than the transparent conductive coating.

**[00130]** The touch panel of any of the preceding sixteen paragraphs may be coupled to a liquid crystal panel, and/or may have a visible transmission of at least 70%.

**[00131]** The forgoing exemplary embodiments are intended to provide an understanding of the disclosure to one of ordinary skill in the art. The forgoing description is not intended to limit the inventive concept described in this application, the scope of which is defined in the following claims.

## WHAT IS CLAIMED IS:

1. A capacitive touch panel, comprising:
  - a glass substrate;
  - a patterned multi-layer transparent conductive coating supported by the glass substrate, the multi-layer transparent conductive coating including at least one conductive layer comprising silver, a dielectric layer located between at least the glass substrate and the conductive layer comprising silver, and a dielectric layer comprising one or more of: zirconium oxide, silicon nitride, and tin oxide located over the conductive layer comprising silver, each of said layers of the multi-layer transparent conductive coating patterned in the same manner;
  - a plurality of electrodes configured for allowing touch position to be determined, wherein at least some of the electrodes comprise the multi-layer transparent conductive coating; and
  - a processor configured for determining touch position on the touch panel;
  - wherein the processor is in electrical communication with at least some of the electrodes, for determining touch position on the touch panel; and
  - wherein the plurality of electrodes are supported by the glass substrate.
  
2. The capacitive touch panel of claim 1, wherein the plurality of electrodes comprise transmit electrodes and receive electrodes, wherein the transmit electrodes have a higher sheet resistance ( $R_s$ ) than do the receive electrodes, and wherein the transmit

electrodes have a sheet resistance ( $R_s$ ) at least 1 ohm/square higher than a sheet resistance of the receive electrodes.

3. The capacitive touch panel of claim 2, wherein the transmit electrodes have a sheet resistance ( $R_s$ ) at least 5 ohms/square higher than a sheet resistance of the receive electrodes.

4. The capacitive touch panel of claim 2, wherein the transmit electrodes have a sheet resistance ( $R_s$ ) at least 10 ohms/square higher than a sheet resistance of the receive electrodes.

5. The capacitive touch panel of claim 2, wherein the transmit electrodes have a sheet resistance ( $R_s$ ) at least 15 ohms/square higher than a sheet resistance of the receive electrodes.

6. The capacitive touch panel of any of claims 2-5, wherein the transmit electrodes have a sheet resistance of from about 15-50 ohms/square, and the receive electrodes have a sheet resistance of from about 1-14 ohms/square.

7. The capacitive touch panel of any of claims 2-5, wherein the transmit electrodes have a sheet resistance of from about 20-50 ohms/square, and the receive electrodes have a sheet resistance of from about 2-12 ohms/square.

8. The capacitive touch panel of any of claims 2-5, wherein the transmit electrodes have a sheet resistance of from about 20-40 ohms/square, and the receive electrodes have a sheet resistance of from about 2-10 ohms/square.

9. The capacitive touch panel of any of claims 2-8, wherein the transmit electrodes comprise the patterned multi-layer transparent conductive coating, and wherein the conductive layer comprising silver of the transmit electrodes is doped.

10. The capacitive touch panel of claim 9, wherein the conductive layer comprising silver is doped with from about 0.05 to 3.0% (wt.%) of one or more of Zn, Pt, Pd, Ti, and Al.

11. The capacitive touch panel of any of claims 9-10, wherein the conductive layer comprising silver is doped with from about 0.1 to 2.0% (wt.%) of one or more of Zn, Pt, Pd, Ti, and Al.

12. The capacitive touch panel of any of claims 9-11, wherein the conductive layer comprising silver is doped with from about 0.1 to 0.5% (wt.%) of one or more of Zn, Pt, Pd, Ti, and Al.

13. The capacitive touch panel of any preceding claim, wherein the coating further comprises a layer over and contacting the conductive layer comprising silver which comprises Ni and/or Cr.

14. The capacitive touch panel of any preceding claim, wherein the transparent conductive coating has a sheet resistance of less than or equal to about 40 ohms/square.

15. The capacitive touch panel of any preceding claim, wherein the dielectric layer comprising one or more of: zirconium oxide, silicon nitride, and tin oxide comprises  $ZrO_2$ .

16. The capacitive touch panel of any preceding claim, wherein the dielectric layer comprising one or more of zirconium oxide, silicon nitride, and tin oxide, comprises silicon nitride.

17. The capacitive touch panel of any preceding claim, wherein the dielectric layer comprising one or more of zirconium oxide, silicon nitride, and tin oxide, comprises silicon nitride and further comprises oxygen.

18. The capacitive touch panel of any preceding claim, wherein the dielectric layer located between at least the glass substrate and the conductive layer comprising silver comprises an oxide of titanium.

19. The capacitive touch panel of any preceding claim, wherein the dielectric layer located between at least the glass substrate and the conductive layer comprising silver comprises silicon nitride.

20. The capacitive touch panel of any preceding claim, wherein the transmit electrodes comprise the patterned multi-layer transparent conductive coating, and wherein the multi-layer transparent conductive coating further comprises a layer comprising Ni and Cr that contacts the layer comprising silver, wherein the layer comprising Ni and Cr is located between at least the glass substrate and the conductive layer comprising silver.

21. The capacitive touch panel of claim 20, wherein the layer comprising Ni and Cr further comprises Mo.

22. The capacitive touch panel of any of claims 2-21, wherein the transmit electrodes comprise the patterned multi-layer transparent conductive coating, and wherein the multi-layer transparent conductive coating further comprises a semiconductor layer that contacts the layer comprising silver, wherein the semiconductor layer is located between at least the glass substrate and the conductive layer comprising silver.

23. The capacitive touch panel of any of claims 2-22, wherein the transmit electrodes comprise the patterned multi-layer transparent conductive coating, and

wherein the multi-layer transparent conductive coating further comprises a substantially amorphous dielectric layer that contacts the layer comprising silver, wherein the substantially amorphous dielectric layer is located between at least the glass substrate and the conductive layer comprising silver.

24. The capacitive touch panel of any of claims 2-23, wherein the transmit electrodes comprise the patterned multi-layer transparent conductive coating, and wherein the multi-layer transparent conductive coating further comprises a dielectric layer comprising one or more of silicon oxide, silicon nitride, silicon oxynitride, and titanium oxide that contacts the layer comprising silver, wherein the dielectric layer comprising one or more of silicon oxide, silicon nitride, silicon oxynitride, and titanium oxide is located between at least the glass substrate and the conductive layer comprising silver.

25. The capacitive touch panel of any of claims 2-24, wherein the transmit electrodes and the receive electrodes each comprise the patterned multi-layer transparent conductive coating, wherein the conductive layer comprising silver is a conductor of the transmit electrodes and a second conductive layer comprising silver in the transparent conductive coating is a conductor of the receive electrodes.

26. The capacitive touch panel of any of claims 2-25, wherein the transmit electrodes comprise the patterned multi-layer transparent conductive coating, and the receive electrodes comprise another patterned multi-layer transparent conductive coating,

wherein the another patterned multi-layer transparent conductive coating comprises at least one conductive layer comprising silver, a dielectric layer located between at least the glass substrate and the conductive layer comprising silver, and a dielectric layer comprising one or more of: zirconium oxide, silicon nitride, and tin oxide located over the conductive layer comprising silver.

27. The capacitive touch panel of any of claims 2-26, wherein the transmit electrodes and receive electrodes are substantially parallel to each other.

28. The capacitive touch panel of any of claims 2-27, wherein the transmit electrodes and receive electrodes are coplanar.

29. The capacitive touch panel of any of claims 2-28, wherein the touch panel is provided on a glass door.

30. The capacitive touch panel of claim 29, wherein the glass door is a shower door.

31. The capacitive touch panel of any preceding claim, wherein the touch panel is configured to control a shower functionality.

32. The capacitive touch panel of any preceding claim, wherein the glass substrate is thermally tempered.

33. The capacitive touch panel of any preceding claim, wherein the glass substrate further supports a functional film.

34. The capacitive touch panel of claim 33, wherein, unlike the transparent conductive coating, the functional film is not patterned.

35. The capacitive touch panel of any of claims 33-34, wherein the functional film is one or more of an antiglare film, an anti-microbial film, and an anti-fingerprint film, and is located on an opposite side of the glass substrate than the transparent conductive coating.

36. An assembly comprising the capacitive touch panel of any preceding claim, coupled to a liquid crystal panel.

37. The capacitive touch panel of any preceding claim, wherein the touch panel, including the electrodes, has a visible transmission of at least 70%.

38. A capacitive touch panel, comprising:  
a glass substrate;

a patterned multi-layer transparent conductive coating supported by the glass substrate, the multi-layer transparent conductive coating including at least one conductive layer comprising silver, a dielectric layer located between at least the glass substrate and the conductive layer comprising silver, and a dielectric layer located over the conductive layer comprising silver;

a plurality of electrodes configured for allowing touch position to be determined, wherein at least some of the electrodes comprise the multi-layer transparent conductive coating;

a processor configured for determining touch position on the touch panel;

wherein the processor is in electrical communication with at least some of the electrodes, for determining touch position on the touch panel;

wherein the plurality of electrodes are supported by the glass substrate; and

wherein the plurality of electrodes comprise transmit electrodes and receive electrodes, wherein the transmit electrodes have a higher sheet resistance ( $R_s$ ) than do the receive electrodes, and wherein the transmit electrodes have a sheet resistance ( $R_s$ ) at least 1 ohm/square higher than a sheet resistance of the receive electrodes.

39. The capacitive touch panel of claim 38, wherein the transmit electrodes have a sheet resistance ( $R_s$ ) at least 5 ohms/square higher than a sheet resistance of the receive electrodes.

40. The capacitive touch panel of claim 38, wherein the transmit electrodes have a sheet resistance ( $R_s$ ) at least 10 ohms/square higher than a sheet resistance of the receive electrodes.

41. The capacitive touch panel of claim 38, wherein the transmit electrodes have a sheet resistance of from about 15-50 ohms/square, and the receive electrodes have a sheet resistance of from about 1-14 ohms/square.

42. The capacitive touch panel of claim 38, wherein the transmit electrodes have a sheet resistance of from about 20-50 ohms/square, and the receive electrodes have a sheet resistance of from about 2-12 ohms/square.

43. The capacitive touch panel of claim 38, wherein the transmit electrodes comprise the patterned multi-layer transparent conductive coating, and wherein the conductive layer comprising silver of the transmit electrodes is doped.

44. The capacitive touch panel of claim 43, wherein the conductive layer comprising silver is doped with from about 0.05 to 3.0% (wt.%) of one or more of Zn, Pt, Pd, Ti, and Al.

45. The capacitive touch panel of claim 43, wherein the conductive layer comprising silver is doped with from about 0.1 to 2.0% (wt.%) of one or more of Zn, Pt, Pd, Ti, and Al.

46. The capacitive touch panel of claim 38, wherein each of the dielectric layers comprises silicon nitride.

47. The capacitive touch panel of claim 38, wherein the transmit electrodes comprise the patterned multi-layer transparent conductive coating, and wherein the multi-layer transparent conductive coating further comprises a layer comprising Ni and Cr that contacts the layer comprising silver, wherein the layer comprising Ni and Cr is located between at least the glass substrate and the conductive layer comprising silver.

48. The capacitive touch panel of claim 38, wherein the transmit electrodes comprise the patterned multi-layer transparent conductive coating, and wherein the multi-layer transparent conductive coating further comprises a semiconductor layer that contacts the layer comprising silver, wherein the semiconductor layer is located between at least the glass substrate and the conductive layer comprising silver.

49. The capacitive touch panel of claim 38, wherein the transmit electrodes comprise the patterned multi-layer transparent conductive coating, and wherein the multi-layer transparent conductive coating further comprises a dielectric layer comprising one or more of silicon oxide, silicon nitride, silicon oxynitride, and titanium oxide that contacts the layer comprising silver, wherein the dielectric layer comprising one or more of silicon oxide, silicon nitride, silicon oxynitride, and titanium oxide is located between at least the glass substrate and the conductive layer comprising silver.

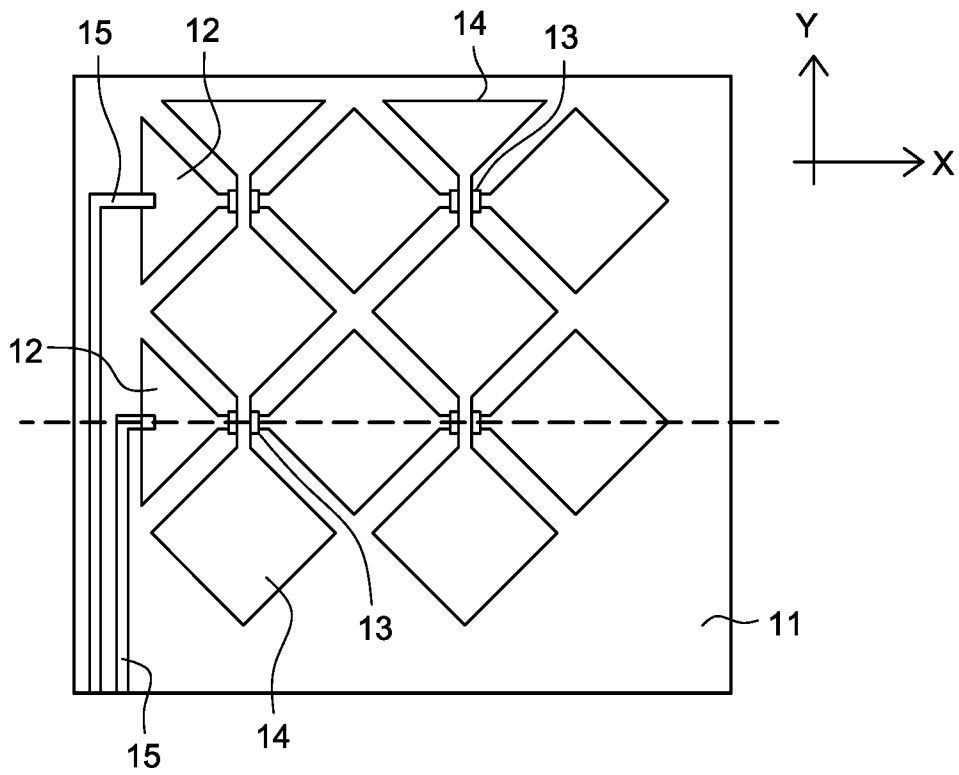
50. The capacitive touch panel of claim 38, wherein the transmit electrodes and the receive electrodes each comprise the patterned multi-layer transparent conductive coating, wherein the conductive layer comprising silver is a conductor of the transmit electrodes and a second conductive layer comprising silver in the transparent conductive coating is a conductor of the receive electrodes.

51. The capacitive touch panel of claim 38, wherein the transmit electrodes comprise the patterned multi-layer transparent conductive coating, and the receive electrodes comprise another patterned multi-layer transparent conductive coating, wherein the another patterned multi-layer transparent conductive coating comprises at least one conductive layer comprising silver, a dielectric layer located between at least the glass substrate and the conductive layer comprising silver, and a dielectric layer comprising one or more of: zirconium oxide, silicon nitride, and tin oxide located over the conductive layer comprising silver.

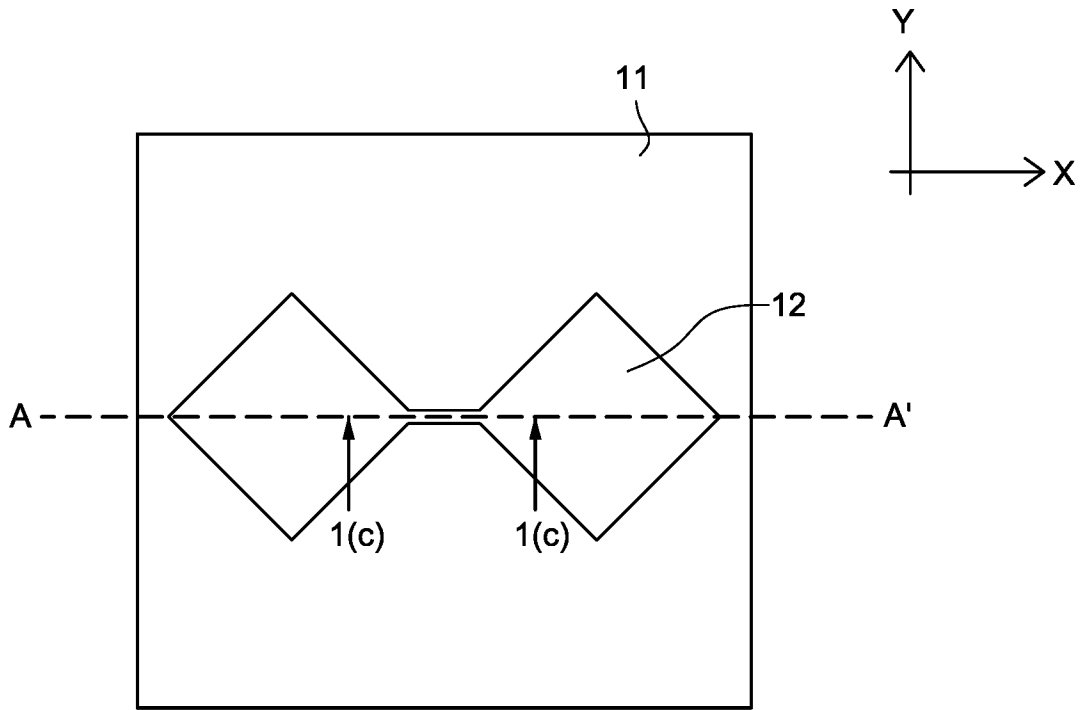
52. The capacitive touch panel of claim 38, wherein the transmit electrodes and receive electrodes are substantially parallel to each other.

53. The capacitive touch panel of claim 38, wherein the transmit electrodes and receive electrodes are coplanar.

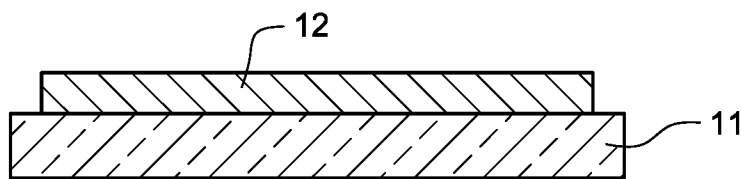
54. The capacitive touch panel of claim 38, wherein the touch panel is provided on a glass door.
55. The capacitive touch panel of claim 38, wherein the glass substrate is thermally tempered.
56. The capacitive touch panel of claim 38, wherein the touch panel, including the electrodes, has a visible transmission of at least 70%.
57. The capacitive touch panel of claim 1, further comprising a laminating layer and another glass substrate, wherein the laminating layer and the multi-layer transparent conductive coating are provided between the glass substrates.
58. The capacitive touch panel of claim 57, wherein the laminating layer comprises PVB.



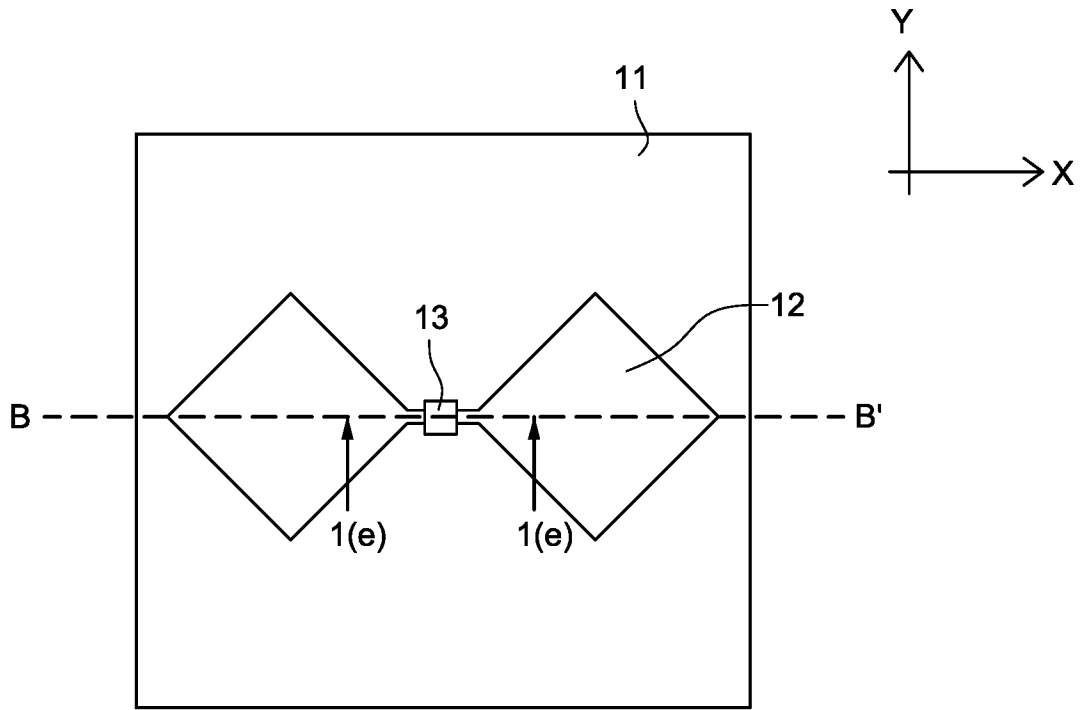
**FIG. 1(a)**  
(Related Art)



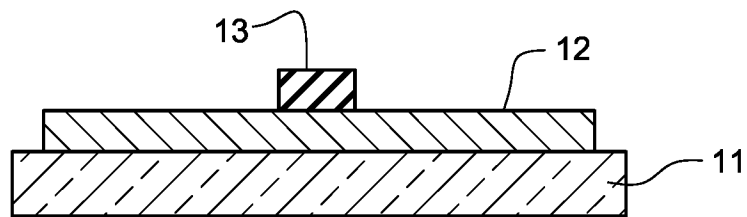
**FIG. 1(b)**  
(Related Art)



**FIG. 1(c)**  
(Related Art)

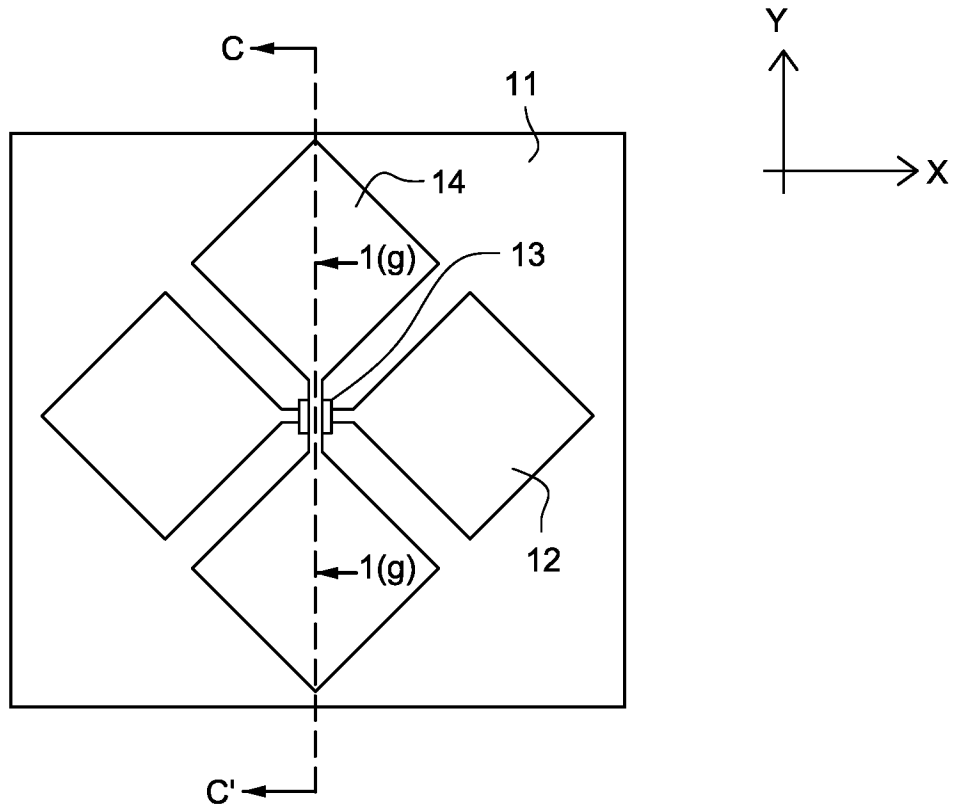


**FIG. 1(d)**  
(Related Art)

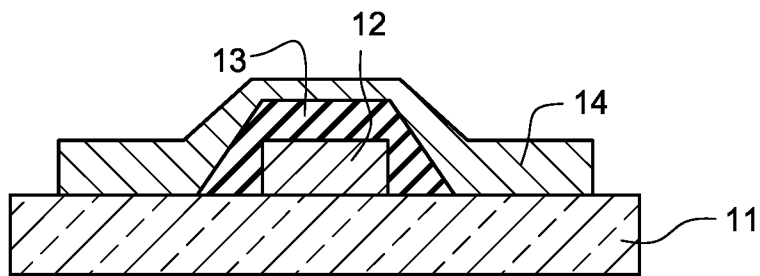


**FIG. 1(e)**  
(Related Art)

4/21



**FIG. 1(f)**  
(Related Art)



**FIG. 1(g)**  
(Related Art)



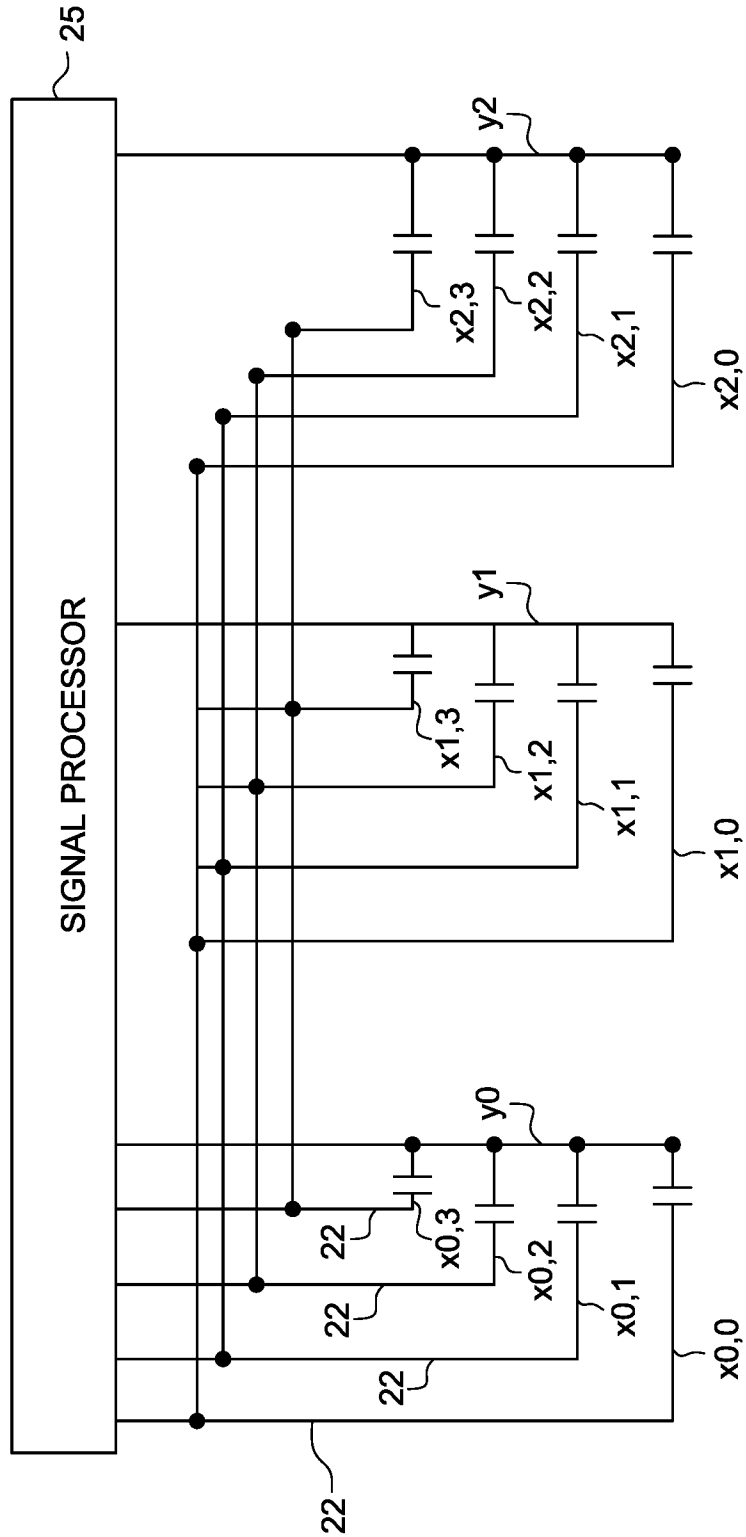
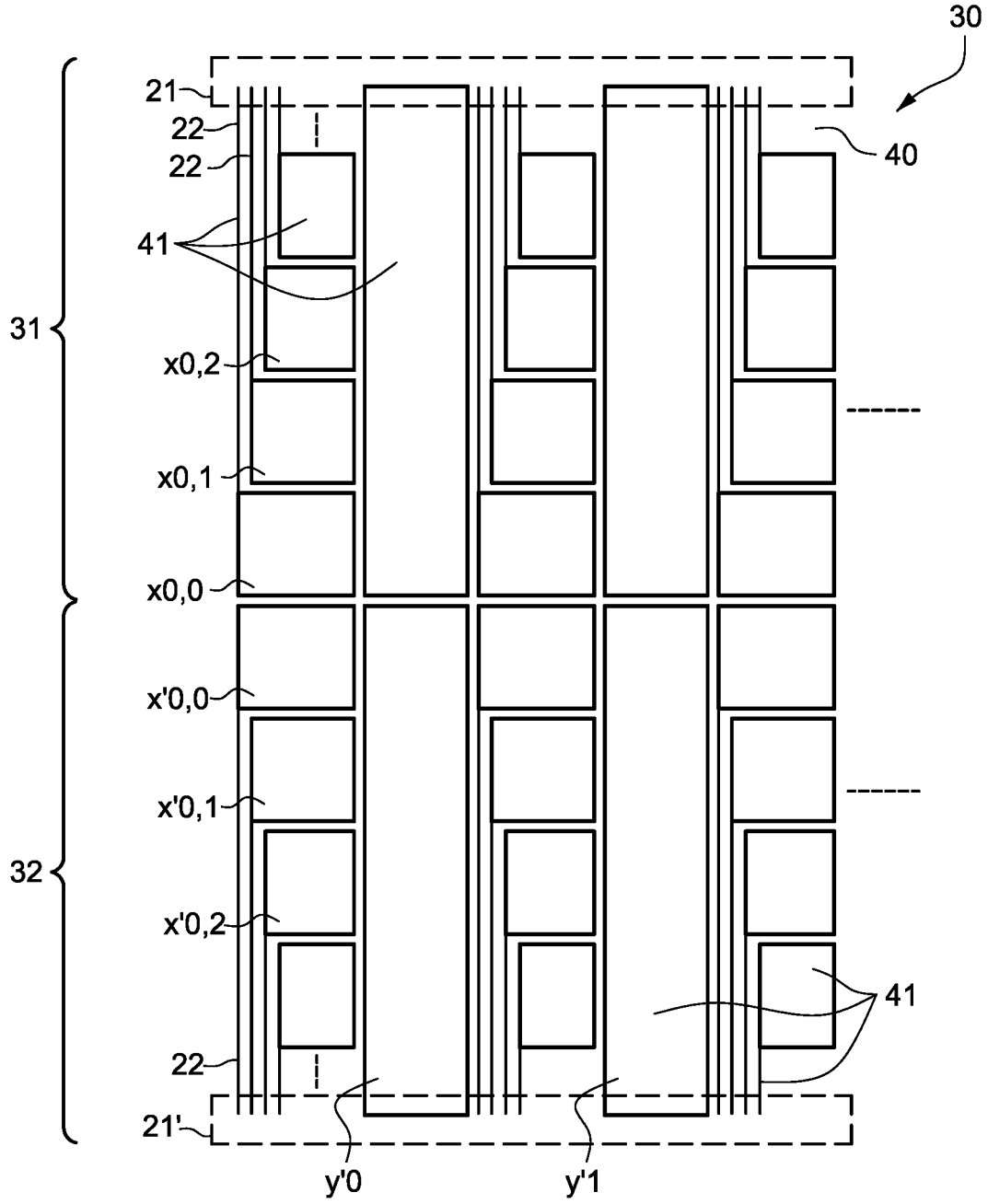
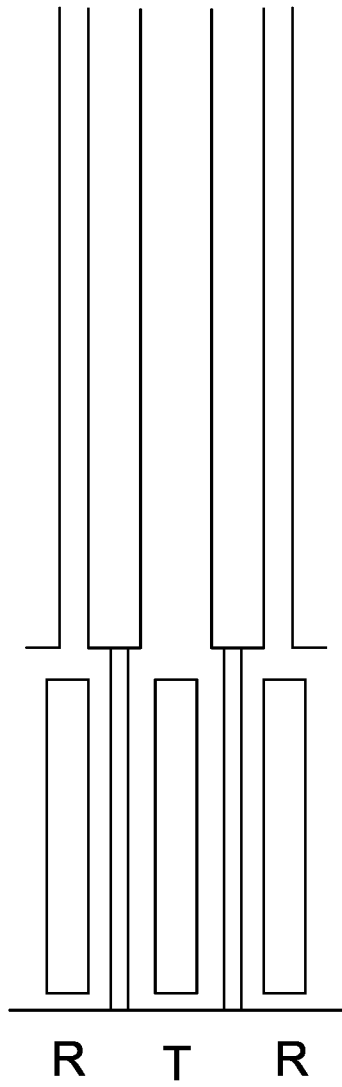


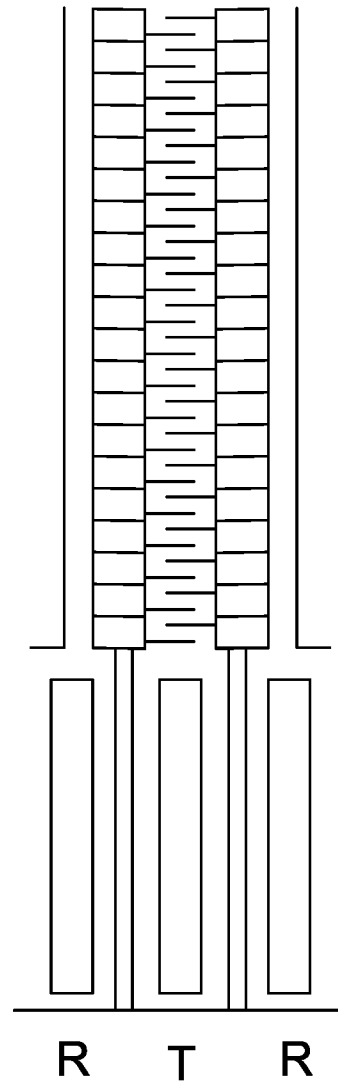
FIG. 2(b)



**FIG. 3(a)**

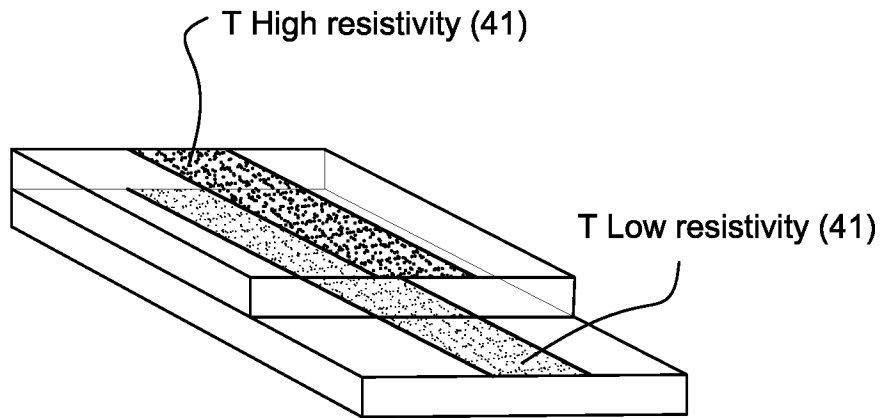


**FIG. 3(b)**

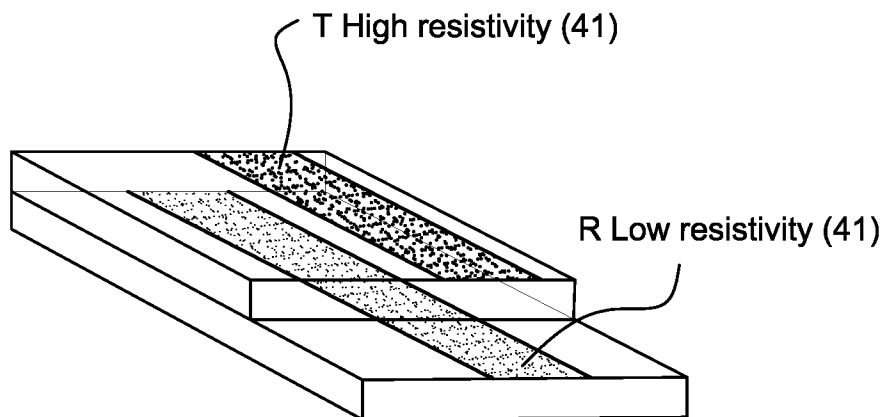


**FIG. 3(c)**

9/21

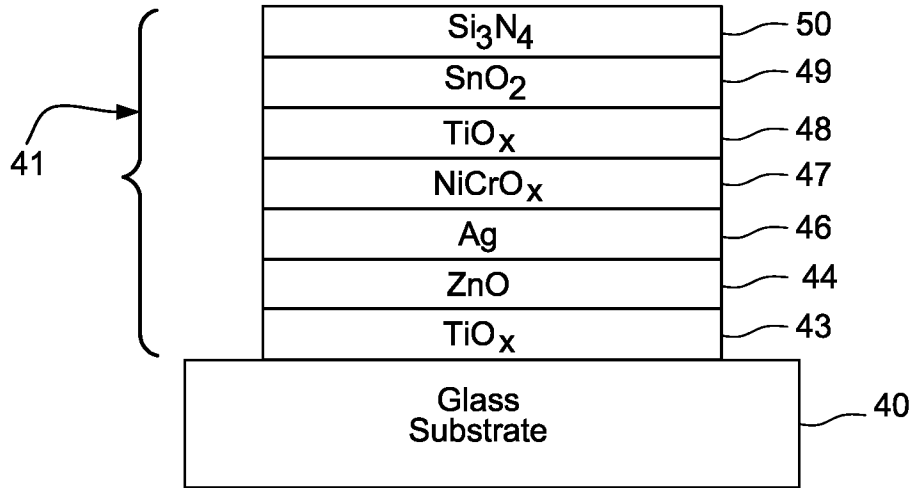


**FIG. 3(d)**

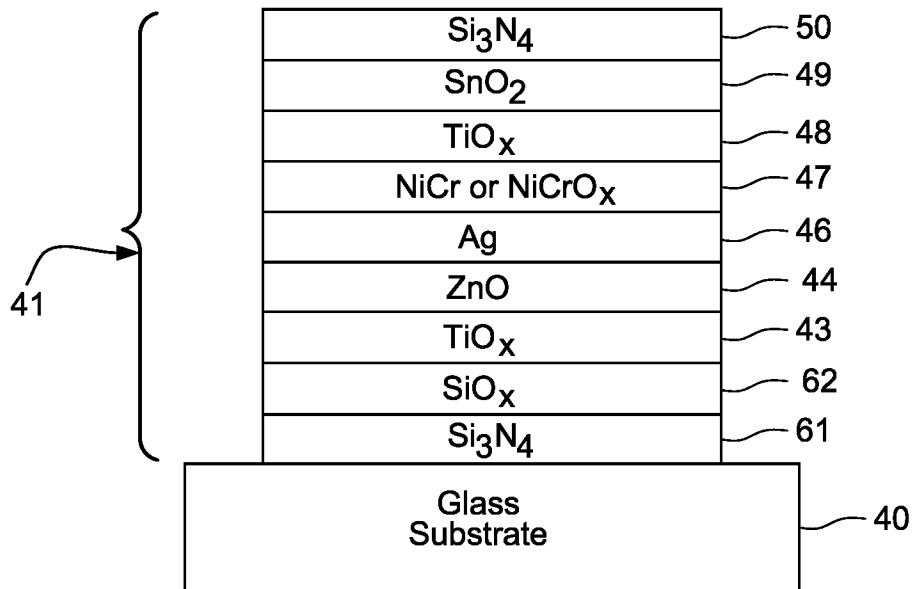


**FIG. 3(e)**

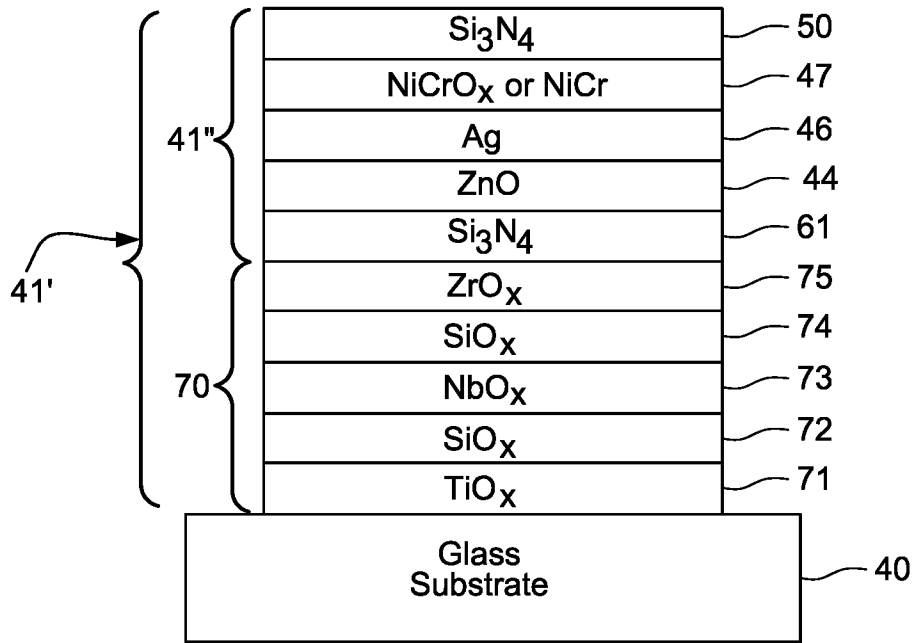
10/21



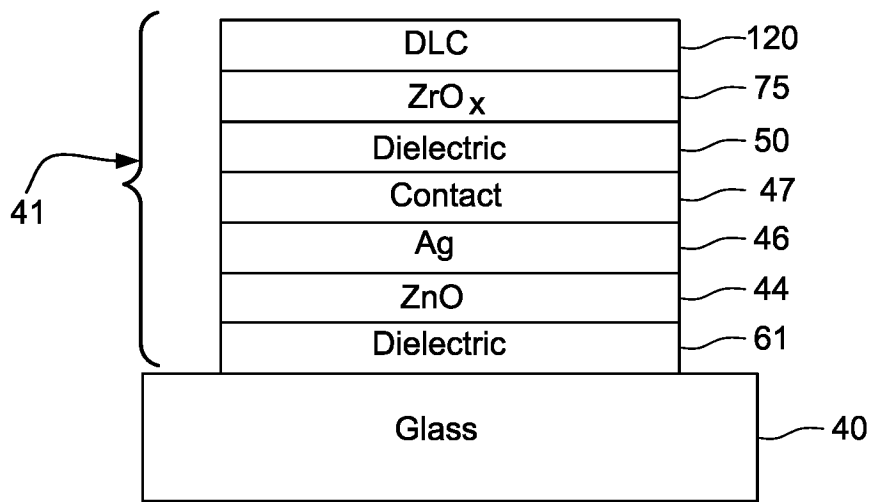
**FIG. 4(a)**



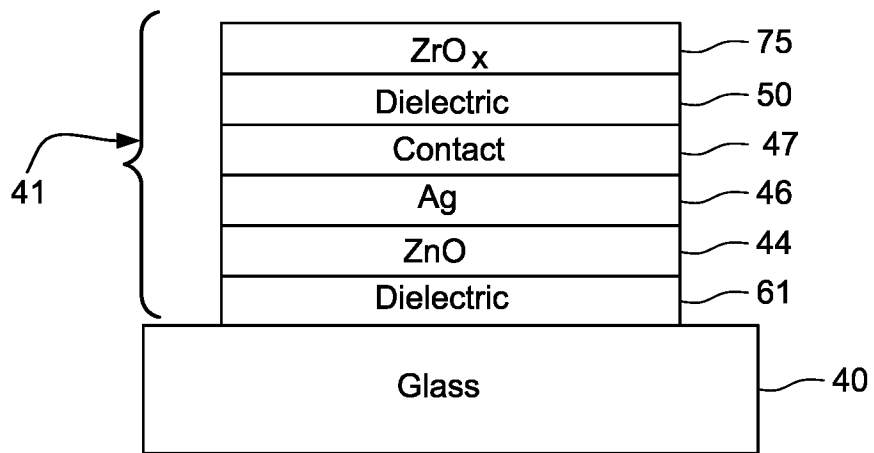
**FIG. 4(b)**



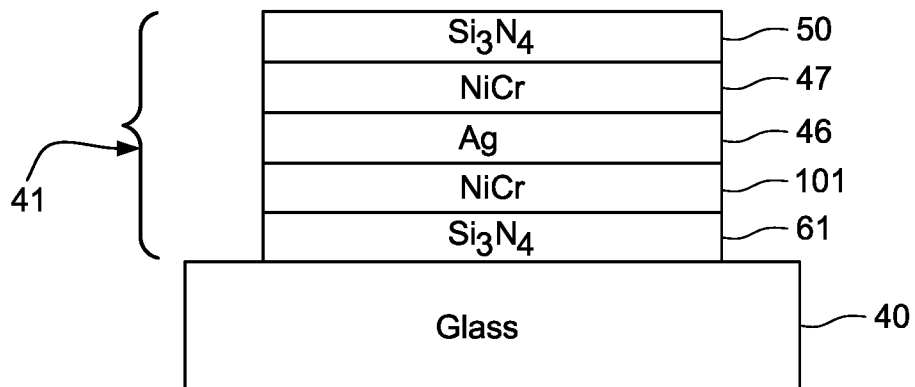
**FIG. 4(c)**



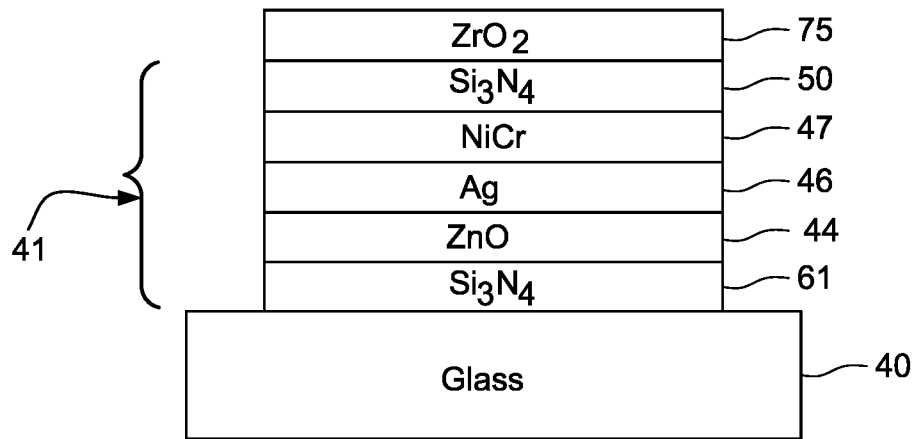
**FIG. 4(d)**



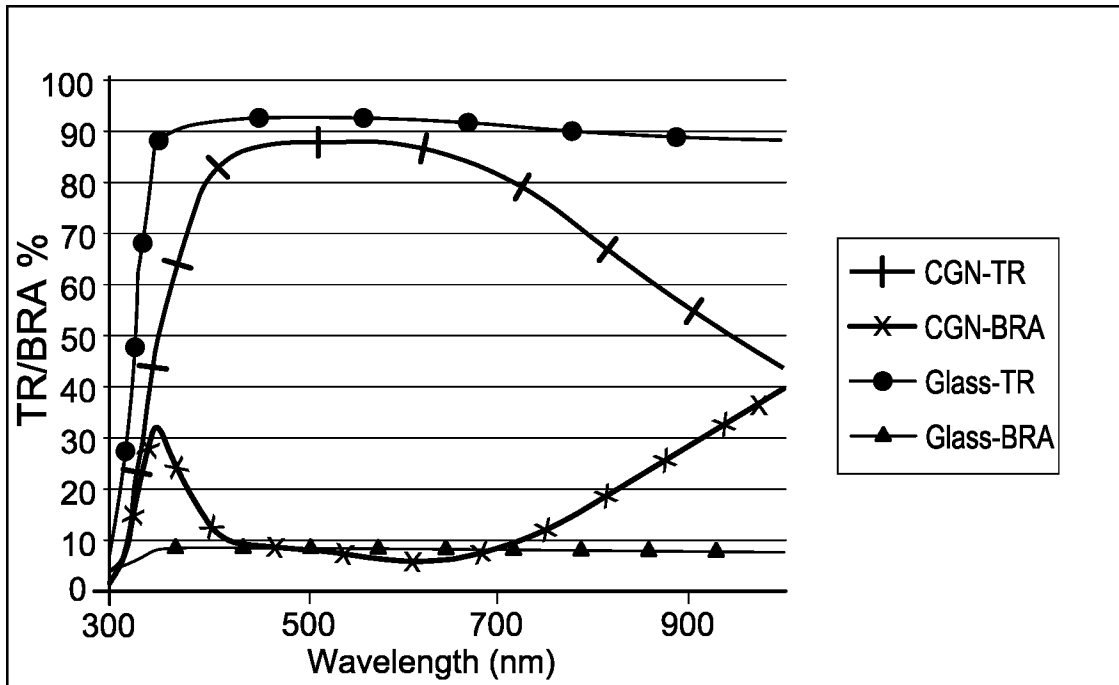
**FIG. 4(e)**



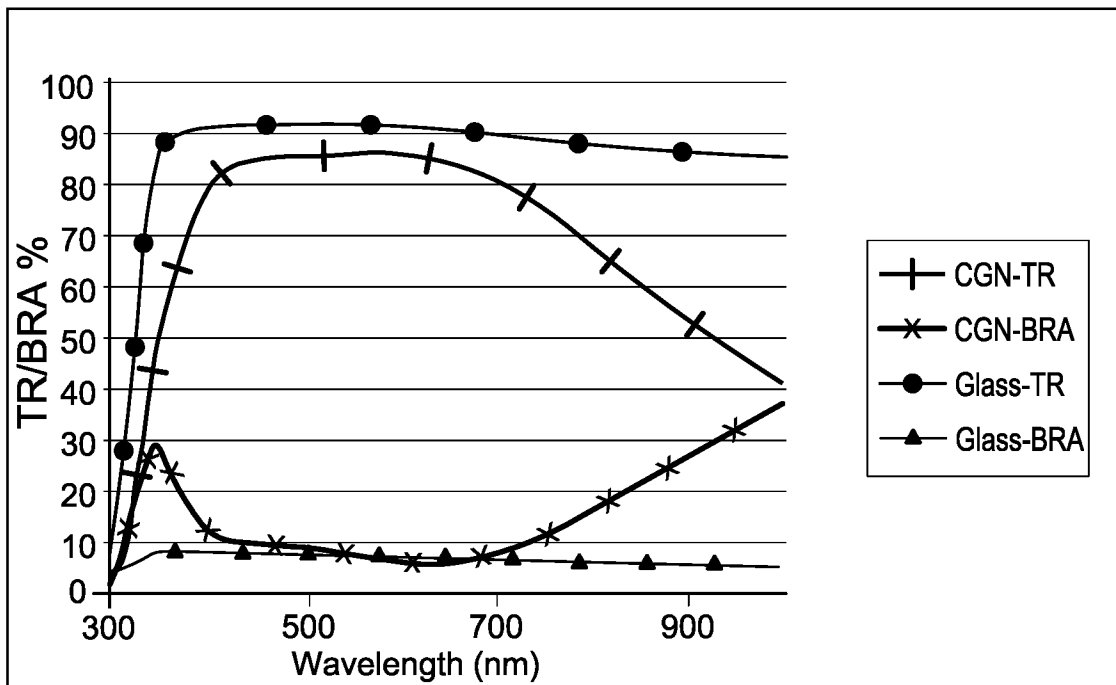
**FIG. 4(f)**



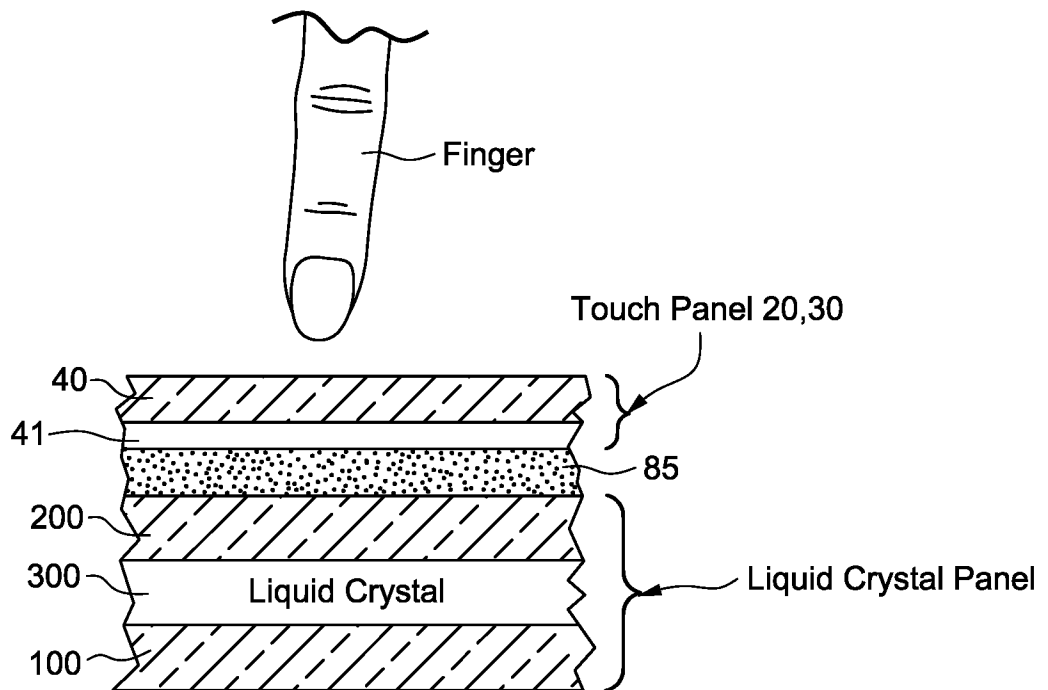
**FIG. 4(g)**



**FIG. 5**  
(Comparative Example)



**FIG. 6**  
(Example 1)



**FIG. 7**

16/21

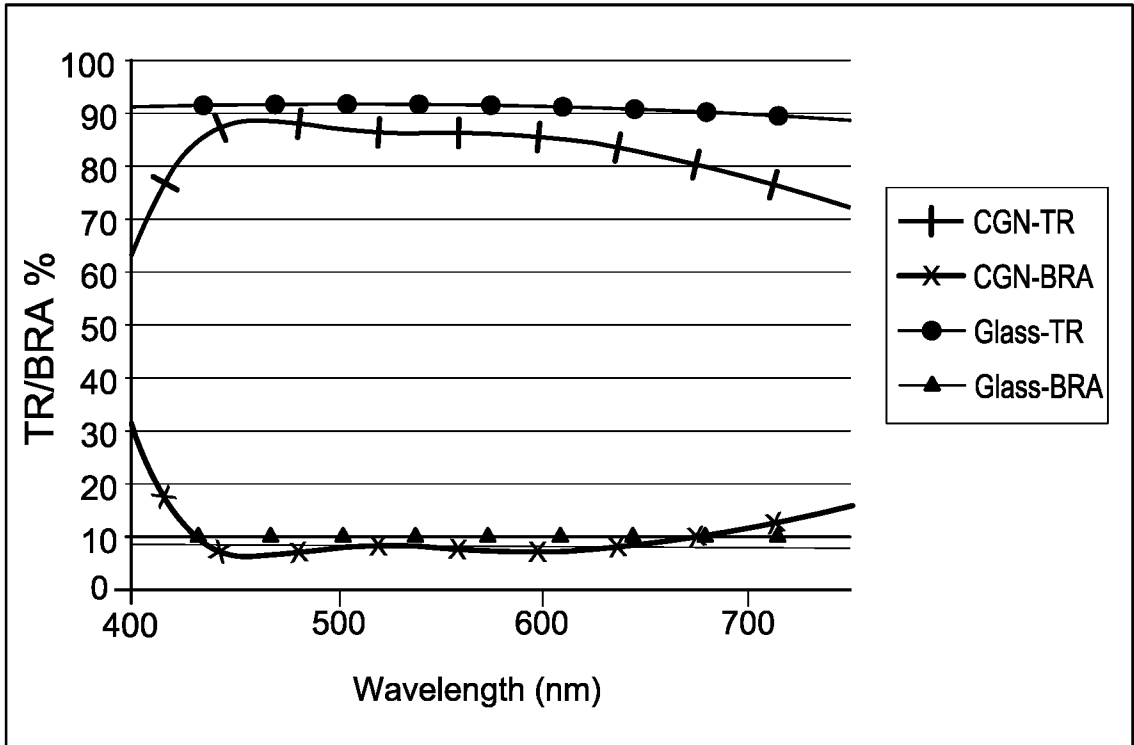


FIG. 8(a)

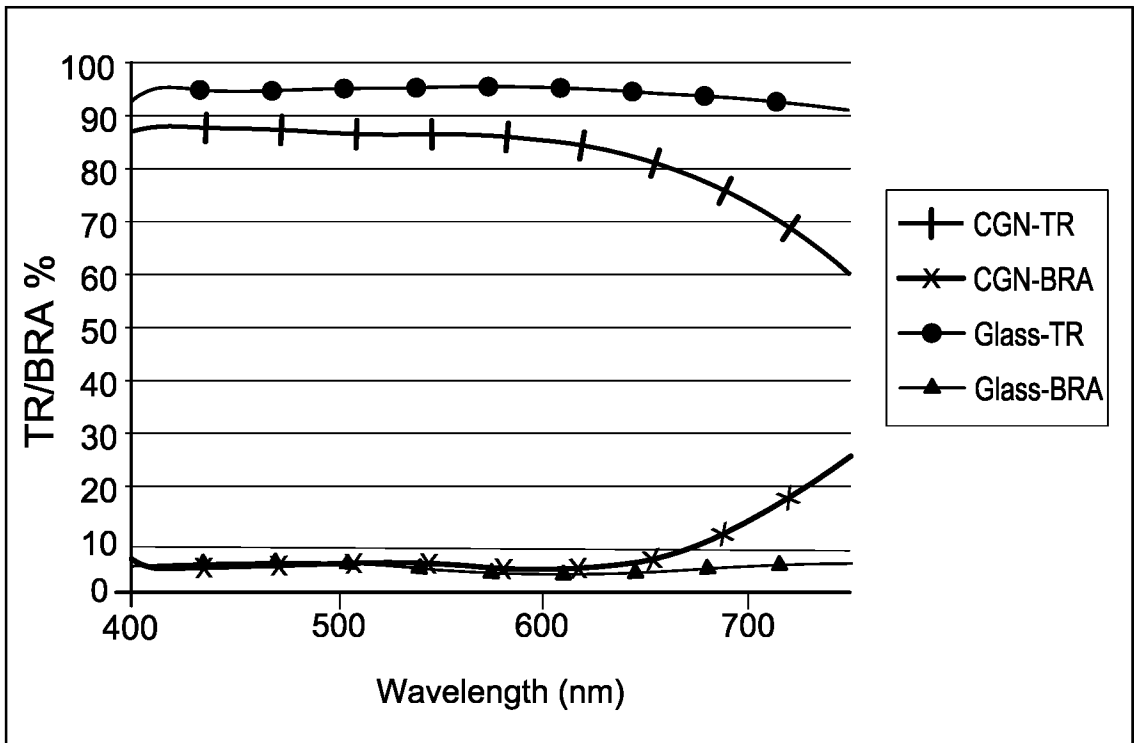
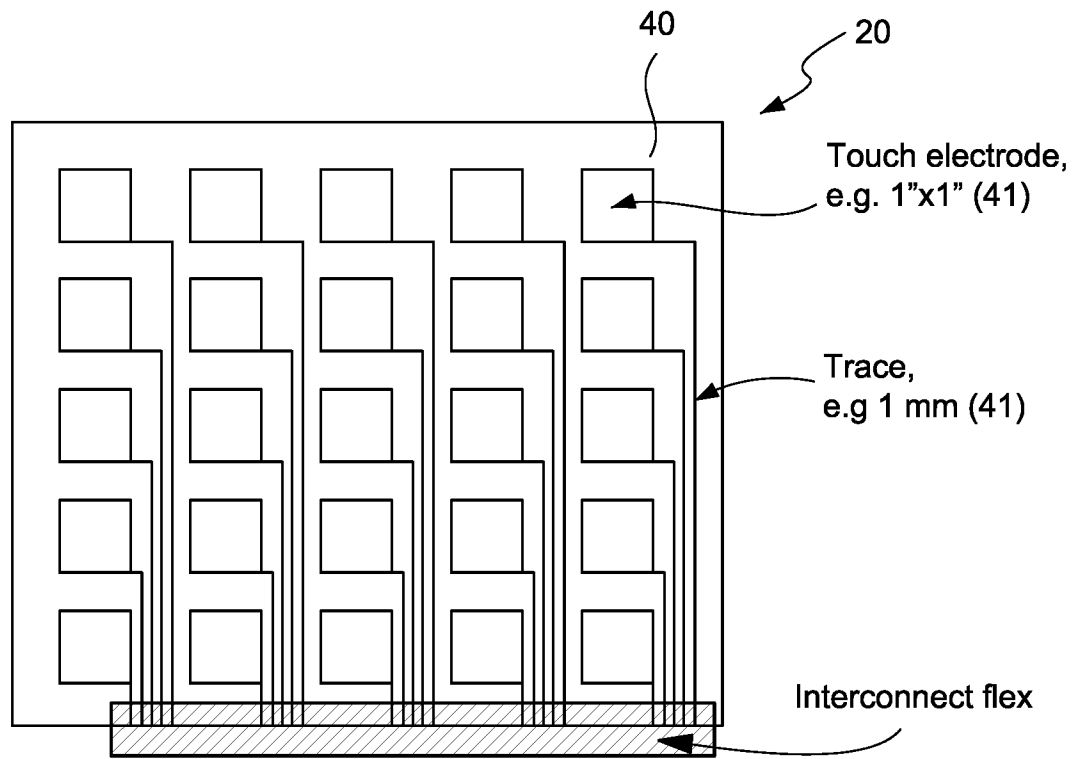
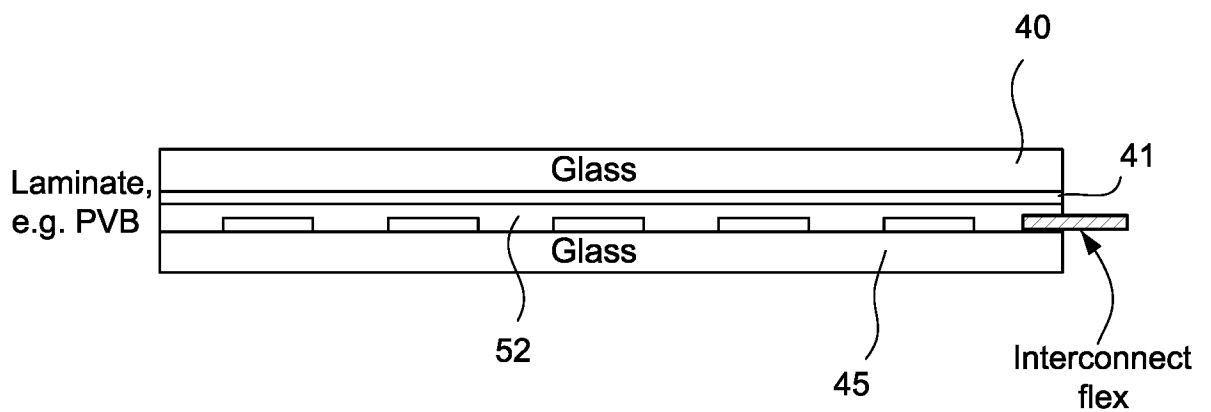


FIG. 8(b)

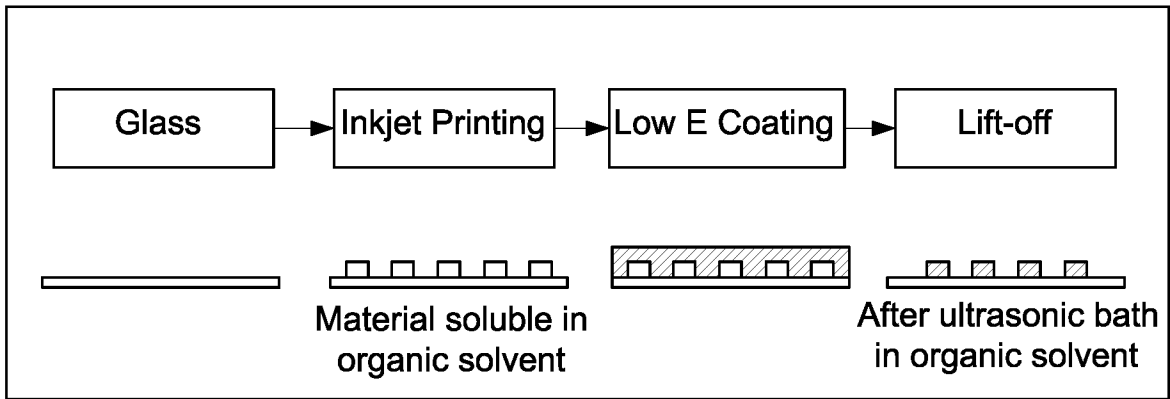
17/21



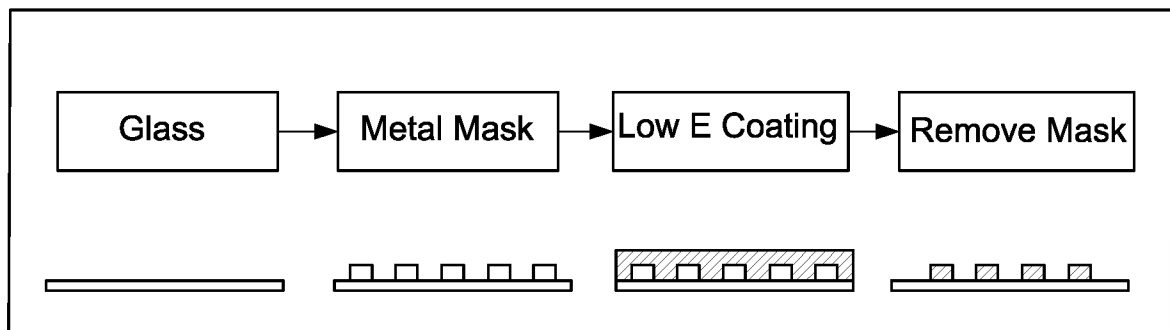
**FIG. 9**



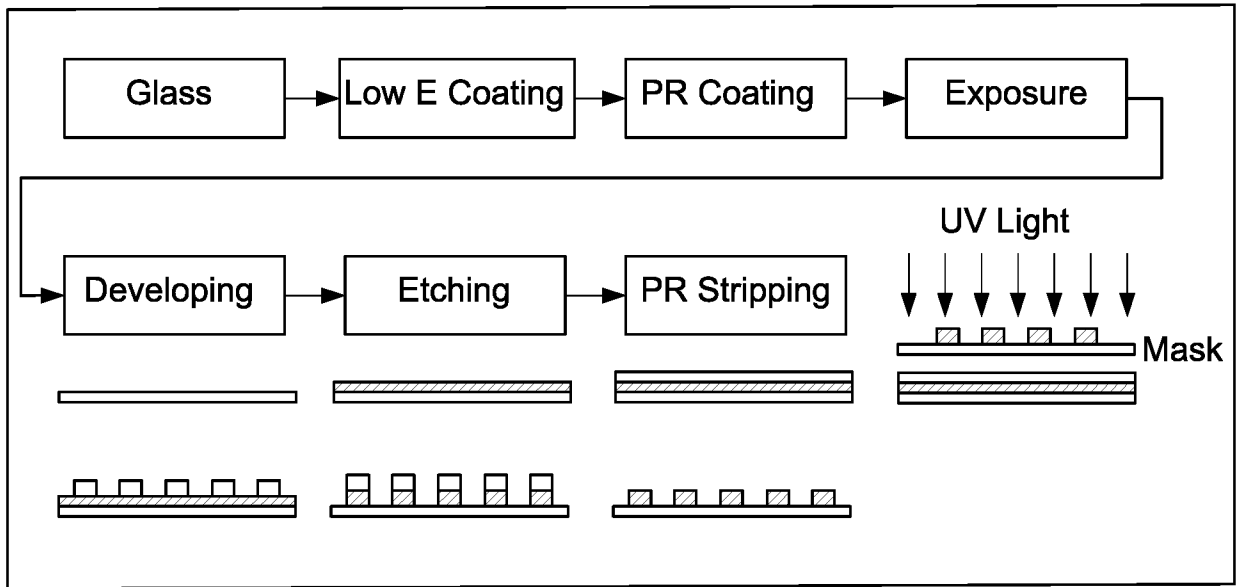
**FIG. 10**



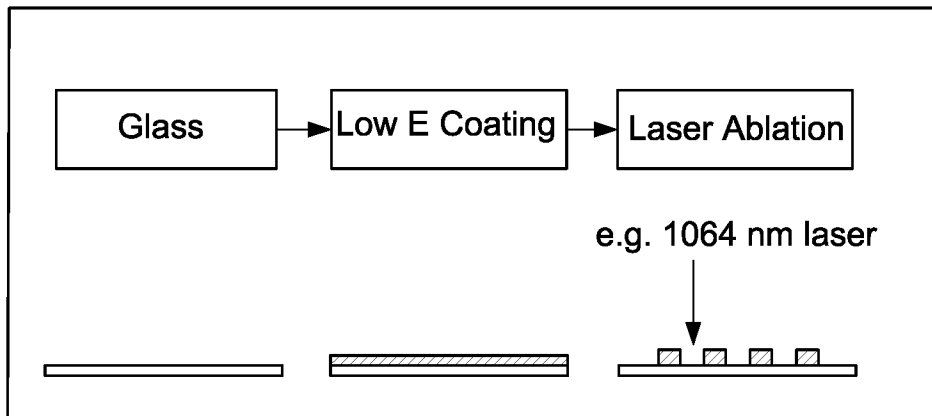
**FIG. 11**



**FIG. 12**

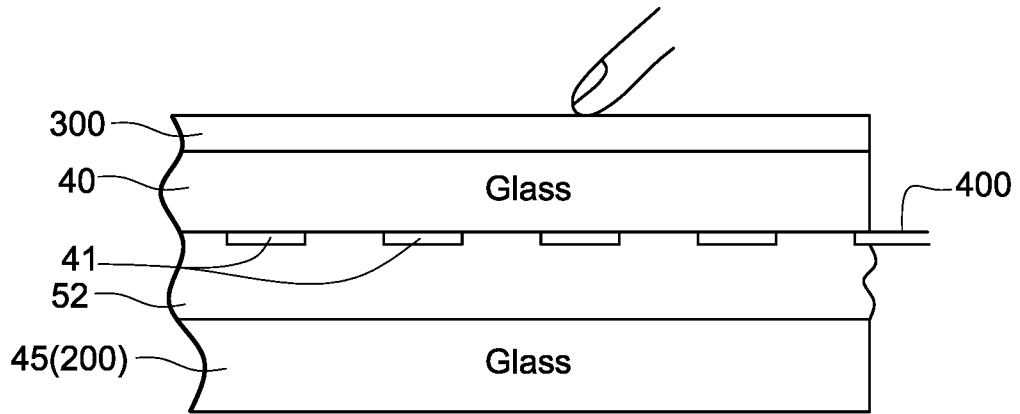


**FIG. 13**

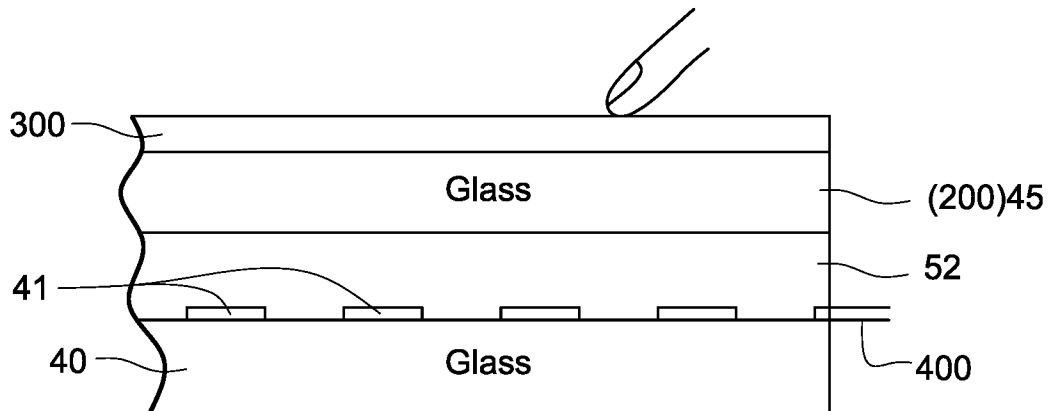


**FIG. 14**

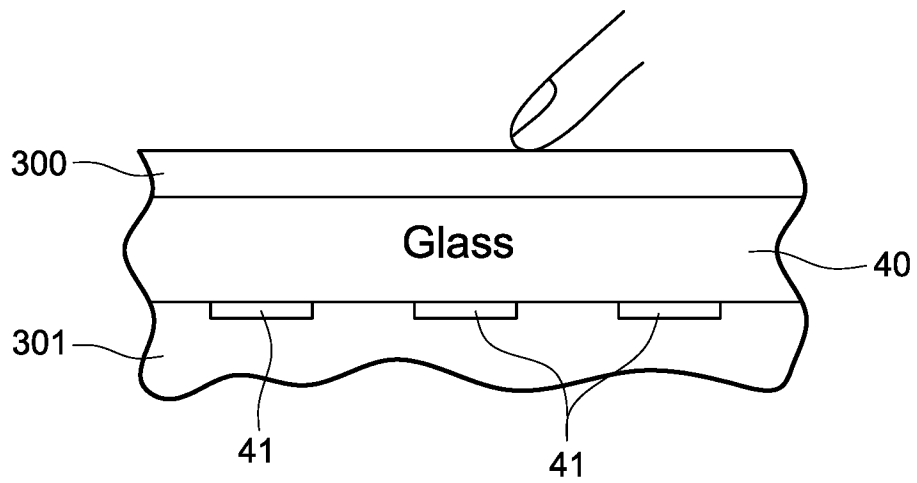
20/21



**FIG. 15**



**FIG. 16**



**FIG. 17**

**INTERNATIONAL SEARCH REPORT**

International application No  
PCT/US2018/066524

**A. CLASSIFICATION OF SUBJECT MATTER**  
 INV. A47K1/00 A47K3/00 A47K11/02 C03C17/36  
 ADD.  
 According to International Patent Classification (IPC) or to both national classification and IPC

**B. FIELDS SEARCHED**  
 Minimum documentation searched (classification system followed by classification symbols)  
 A47K C03C

Documentation searched other than minimum documentation to the extent that such documents are included in the fields searched

Electronic data base consulted during the international search (name of data base and, where practicable, search terms used)  
 EPO-Internal

**C. DOCUMENTS CONSIDERED TO BE RELEVANT**

Category*	Citation of document, with indication, where appropriate, of the relevant passages	Relevant to claim No.
X	US 2017/329166 A1 (AKKASHIAN ERIC W [US] ET AL) 16 November 2017 (2017-11-16) paragraphs [0004] - [0013], [0035] - [0064]; figures 4-7; tables 1,2 -----	1-58
X	US 2017/344157 A1 (KRASNOV ALEXEY [US] ET AL) 30 November 2017 (2017-11-30) paragraphs [0002], [0009] - [0039]; figures 4(a)-(c) -----	1-58
X	WO 2013/002985 A1 (GUARDIAN INDUSTRIES [US]; KRASNOV ALEXEY [US]; IMRAN MUHAMMAD [US]; DE) 3 January 2013 (2013-01-03) paragraphs [0002] - [0018], [0037] - [0057]; figures 4-17 ----- -/--	1-58

Further documents are listed in the continuation of Box C.

See patent family annex.

\* Special categories of cited documents :

"A" document defining the general state of the art which is not considered to be of particular relevance	"T" later document published after the international filing date or priority date and not in conflict with the application but cited to understand the principle or theory underlying the invention
"E" earlier application or patent but published on or after the international filing date	"X" document of particular relevance; the claimed invention cannot be considered novel or cannot be considered to involve an inventive step when the document is taken alone
"L" document which may throw doubts on priority claim(s) or which is cited to establish the publication date of another citation or other special reason (as specified)	"Y" document of particular relevance; the claimed invention cannot be considered to involve an inventive step when the document is combined with one or more other such documents, such combination being obvious to a person skilled in the art
"O" document referring to an oral disclosure, use, exhibition or other means	"&" document member of the same patent family
"P" document published prior to the international filing date but later than the priority date claimed	

Date of the actual completion of the international search <b>20 March 2019</b>	Date of mailing of the international search report <b>09/04/2019</b>
---	---

Name and mailing address of the ISA/ European Patent Office, P.B. 5818 Patentlaan 2 NL - 2280 HV Rijswijk Tel. (+31-70) 340-2040, Fax: (+31-70) 340-3016	Authorized officer <b>Lecerf, Nicolas</b>
--	--

## INTERNATIONAL SEARCH REPORT

International application No  
PCT/US2018/066524

C(Continuation). DOCUMENTS CONSIDERED TO BE RELEVANT		
Category*	Citation of document, with indication, where appropriate, of the relevant passages	Relevant to claim No.
X	EP 2 794 502 B1 (CT LUXEMBOURGEOIS RECH VERRE [LU]) 5 October 2016 (2016-10-05) paragraphs [0002] - [0030], [0034] - [0051]; figures 1,2 -----	1-58
X,P	WO 2018/017629 A1 (GUARDIAN GLASS LLC [US]) 25 January 2018 (2018-01-25) paragraphs [0004] - [0005], [0035] - [0044], [0055] - [0069]; figures 4-6; tables 1,2 -----	1-58
X,P	WO 2018/017357 A1 (GUARDIAN GLASS LLC [US]) 25 January 2018 (2018-01-25) paragraphs [0003], [0012] - [0014], [0035] - [0064]; figures 4-6; tables 1,2 -----	1-58
A	WO 2007/008643 A2 (GUARDIAN INDUSTRIES [US]; CT LUXEMBOURGEOIS RECH VERRE [LU]; NUNEZ-REG) 18 January 2007 (2007-01-18) paragraphs [0016] - [0019], [0031] - [0032]; figure 1 -----	1-58
A	WO 2006/020641 A2 (CT LUXEMBOURGEOIS RECH VERRE [LU]; GUARDIAN INDUSTRIES [US]; LEMMER JE) 23 February 2006 (2006-02-23) paragraphs [0036] - [0056]; figure 3; example 1 -----	1-58

# INTERNATIONAL SEARCH REPORT

Information on patent family members

International application No PCT/US2018/066524
---

Patent document cited in search report	Publication date	Patent family member(s)	Publication date
US 2017329166	A1	16-11-2017	NONE
-----			
US 2017344157	A1	30-11-2017	NONE
-----			
WO 2013002985	A1	03-01-2013	EP 2727163 A1 07-05-2014
			TW 201307950 A 16-02-2013
			US 2013004678 A1 03-01-2013
			WO 2013002985 A1 03-01-2013
-----			
EP 2794502	B1	05-10-2016	CA 2868125 A1 27-06-2013
			EP 2794502 A1 29-10-2014
			ES 2604320 T3 06-03-2017
			PL 2794502 T3 31-08-2017
			RU 2014129764 A 10-02-2016
			US 2013164464 A1 27-06-2013
			US 2016108249 A1 21-04-2016
			WO 2013096080 A1 27-06-2013
-----			
WO 2018017629	A1	25-01-2018	NONE
-----			
WO 2018017357	A1	25-01-2018	NONE
-----			
WO 2007008643	A2	18-01-2007	CA 2612261 A1 18-01-2007
			EP 1904293 A2 02-04-2008
			US 2007009746 A1 11-01-2007
			WO 2007008643 A2 18-01-2007
-----			
WO 2006020641	A2	23-02-2006	CA 2579489 A1 23-02-2006
			EP 1778476 A2 02-05-2007
			US 2005202255 A1 15-09-2005
			US 2006207291 A1 21-09-2006
			WO 2006020641 A2 23-02-2006
-----			