

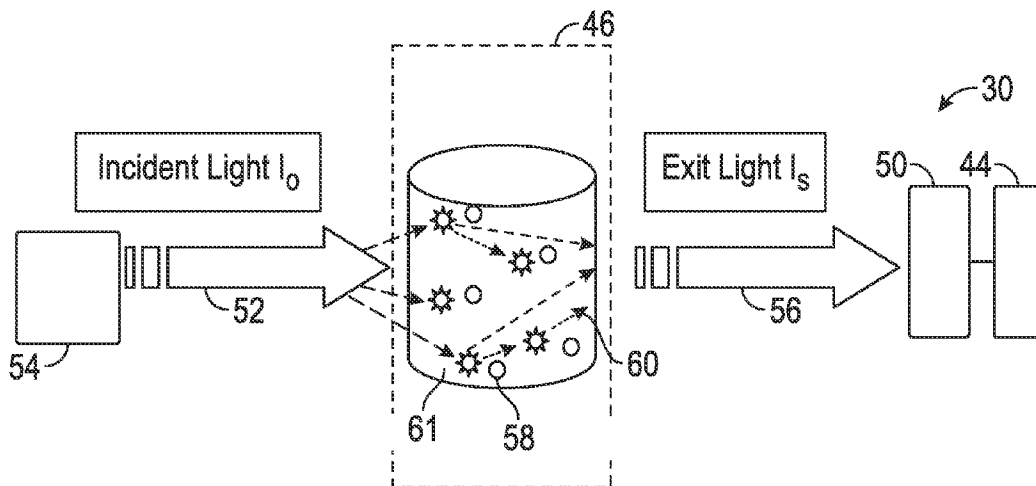

(86) Date de dépôt PCT/PCT Filing Date: 2015/08/06
(87) Date publication PCT/PCT Publication Date: 2016/02/11
(45) Date de délivrance/Issue Date: 2020/07/28
(85) Entrée phase nationale/National Entry: 2018/02/07
(86) N° demande PCT/PCT Application No.: US 2015/043914
(87) N° publication PCT/PCT Publication No.: 2016/022746
(30) Priorité/Priority: 2014/08/08 (US62/035,205)

(51) Cl.Int./Int.Cl. *G01N 21/31* (2006.01),
G01N 21/03 (2006.01), *G01N 21/05* (2006.01)
(72) Inventeur/Inventor:
EARLEY, DRUMMOND, US
(73) Propriétaire/Owner:
WSP GLOBAL INC., CA
(74) Agent: BORDEN LADNER GERVAIS LLP

(54) Titre : SYSTEME DE LIXIVIATION QUI AMELIORE LA SURVEILLANCE D'ESPECES DANS UN FLUIDE
(54) Title: LEACHING SYSTEM WHICH ENHANCES MONITORING OF SPECIES IN A FLUID



(57) **Abrégé/Abstract:**

A technique facilitates analysis of constituents in leaching operations by utilizing light energy and fiber optic transmission of light during the leaching operations. The light is used in situ in combination with a flow cell to measure desired constituents, e.g. copper, in a fluid flow stream. Additionally, the data obtained via the flow cell may be provided to a data processing system which may be used to automatically provide information, e.g. constituent concentration, within the flow stream. In many applications, the in situ fiber-optic transmission system and flow cell may be used in combination with the data processing system to provide real time information on the flow stream.

(12) INTERNATIONAL APPLICATION PUBLISHED UNDER THE PATENT COOPERATION TREATY (PCT)

CORRECTED VERSION

(19) World Intellectual Property
Organization
International Bureau(10) International Publication Number
WO 2016/022746 A9(43) International Publication Date
11 February 2016 (11.02.2016)

- (51) International Patent Classification:
G01N 21/31 (2006.01) *G01N 21/05* (2006.01)
G01N 21/03 (2006.01)
- (21) International Application Number:
PCT/US2015/043914
- (22) International Filing Date:
6 August 2015 (06.08.2015)
- (25) Filing Language: English
- (26) Publication Language: English
- (30) Priority Data:
62/035,205 8 August 2014 (08.08.2014) US
- (71) Applicant (for US only): **SCHLUMBERGER TECHNOLOGY CORPORATION** [US/US]; 300 Schlumberger Drive, Sugar Land, TX 77478 (US).
- (71) Applicant (for CA only): **SCHLUMBERGER CANADA LIMITED** [CA/CA]; 125 - 9 Avenue SE, Calgary, Alberta T2G 0P6 (CA).
- (71) Applicant (for FR only): **SERVICES PETROLIERS SCHLUMBERGER** [FR/FR]; 42 rue Saint Dominique, 75007 Paris (FR).
- (71) Applicant (for all designated States except CA, FR, US): **SCHLUMBERGER TECHNOLOGY B.V.** [NL/NL]; Parkstraat 83-89m, NL-2514 JG The Hague (NL).
- (72) Inventor: **EARLEY, Drummond**; 50 S. Boulder Circle #5034, Boulder, CO 80303 (US).
- (74) Agents: **STEINHEIDER, Matthew et al.**; 10001 Richmond Avenue, IP Administration Center of Excellence, Room 4720, Houston, TX 77042 (US).
- (81) Designated States (unless otherwise indicated, for every kind of national protection available): AE, AG, AL, AM, AO, AT, AU, AZ, BA, BB, BG, BH, BN, BR, BW, BY, BZ, CA, CH, CL, CN, CO, CR, CU, CZ, DE, DK, DM, DO, DZ, EC, EE, EG, ES, FI, GB, GD, GE, GH, GM, GT, HN, HR, HU, ID, IL, IN, IR, IS, JP, KE, KG, KN, KP, KR, KZ, LA, LC, LK, LR, LS, LU, LY, MA, MD, ME, MG, MK, MN, MW, MX, MY, MZ, NA, NG, NI, NO, NZ, OM, PA, PE, PG, PH, PL, PT, QA, RO, RS, RU, RW, SA, SC, SD, SE, SG, SK, SL, SM, ST, SV, SY, TH, TJ, TM, TN, TR, TT, TZ, UA, UG, US, UZ, VC, VN, ZA, ZM, ZW.
- (84) Designated States (unless otherwise indicated, for every kind of regional protection available): ARIPO (BW, GH, GM, KE, LR, LS, MW, MZ, NA, RW, SD, SL, ST, SZ, TZ, UG, ZM, ZW), Eurasian (AM, AZ, BY, KG, KZ, RU, TJ, TM), European (AL, AT, BE, BG, CH, CY, CZ, DE, DK, EE, ES, FI, FR, GB, GR, HR, HU, IE, IS, IT, LT, LU, LV, MC, MK, MT, NL, NO, PL, PT, RO, RS, SE, SI, SK, SM, TR), OAPI (BF, BJ, CF, CG, CI, CM, GA, GN, GQ, GW, KM, ML, MR, NE, SN, TD, TG).
- Published:
— with international search report (Art. 21(3))
- (48) Date of publication of this corrected version:
19 May 2016

[Continued on next page]

(54) Title: LEACHING SYSTEM WHICH ENHANCES MONITORING OF SPECIES IN A FLUID

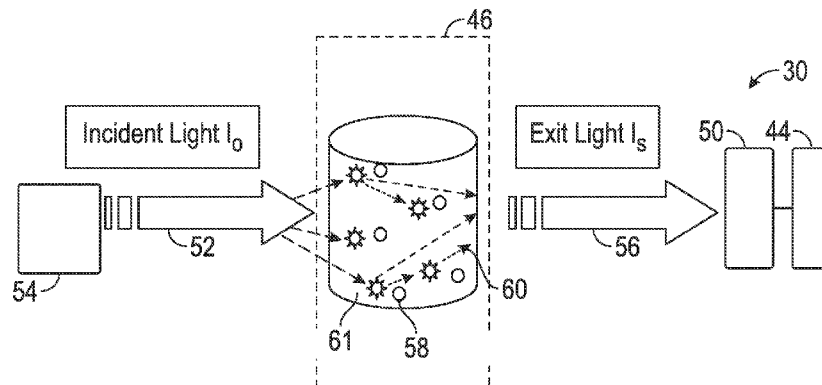

FIG. 3

(57) Abstract: A technique facilitates analysis of constituents in leaching operations by utilizing light energy and fiber optic transmission of light during the leaching operations. The light is used in situ in combination with a flow cell to measure desired constituents, e.g. copper, in a fluid flow stream. Additionally, the data obtained via the flow cell may be provided to a data processing system which may be used to automatically provide information, e.g. constituent concentration, within the flow stream. In many applications, the in situ fiber-optic transmission system and flow cell may be used in combination with the data processing system to provide real time information on the flow stream.

WO 2016/022746 A9 

(15) Information about Correction:
see Notice of 19 May 2016

LEACHING SYSTEM WHICH ENHANCES MONITORING OF SPECIES IN A FLUID

[0001]

BACKGROUND

[0002] Leaching operations, e.g. heap leaching operations, are industrial processes which involve the extraction of metals or sometimes other materials. System monitoring during leaching operations may involve sampling and laboratory analysis of leach solutions by atomic absorption (AA) spectrometry or inductively coupled plasma (ICP) techniques, both of which may involve rigorous sample collection, preservation, processing, and laboratory technician activities in an analytical facility. Although such facilities may be located in a central laboratory of a mine, some mines do not have in-house analytical capabilities. In this situation, the samples are instead shipped to commercial labs in different cities and/or countries. However, such sampling and off-line analysis may be limited in that real-time adjustments to the processing system may not be possible, e.g. adjustments resulting from delay between sample collection and processing. In addition, data collection frequency and detection of time dependent fluctuations may be limited when discrete samples are collected from the process stream (*e.g.*, as compared to a continuous measurement system). These shortcomings have given rise to various in-line systems, such as the Ion Selective Electrodes (ISE) system that has been utilized for copper analysis. However, the ISE systems and/or others have limitations when operating at high solution concentrations and/or in complex solution matrices. As result, ISE and/or other conventional detectors may be primarily utilized to determine copper at low concentrations (*e.g.*, less than about 10 ppm or 10 mg/L) in relatively fresh water.

Such measurements may also not be well suited to poor quality (*e.g.*, high amounts of suspended solids) and/or complex industrial process waters, such as mine leaching circuits.

SUMMARY

[0003] In general, a system and methodology are provided for utilizing light energy, *e.g.* fiber optic transmission of light, in leaching operations. The light is used in-situ in combination with a flow cell to measure desired constituents, *e.g.* copper, in a fluid flow stream. Additionally, the data obtained via the flow cell may be provided to a data processing system which may be used to automatically determine information, such as constituent concentration, within the flow stream. In many applications, the in-situ fiber optic transmission system and flow cell may be used in combination with the data processing system to provide real-time information on the flow stream.

[0004] However, many modifications are possible without materially departing from the teachings of this disclosure. Accordingly, such modifications are intended to be included within the scope of this disclosure.

BRIEF DESCRIPTION OF THE DRAWINGS

[0005] Certain embodiments of the disclosure will hereafter be described with reference to the accompanying drawings, wherein like reference numerals denote like elements. It should be understood, however, that the accompanying figures illustrate the various implementations described herein and are not meant to limit the scope of various technologies described herein, and:

[0006] Figure 1 is a schematic illustration of an example of a leaching system having a distributed fiber optic light system to facilitate constituent measurement, according to an embodiment of the disclosure;

[0007] Figure 2 is a schematic illustration of an example of the distributed fiber optic light system that may be used with the leaching system illustrated in Figure 1, according to an embodiment of the disclosure;

[0008] Figure 3 is a schematic illustration of an example of a fiber optic light system combined with a flow cell and a data processing system, according to an embodiment of the disclosure;

[0009] Figure 4 is a schematic illustration of another example of a fiber optic light system combined with a flow cell and a data processing system, according to an embodiment of the disclosure;

[0010] Figure 5 is an illustration of a table showing an example of a calibration matrix for concentration ranges applicable to solution mining of copper ores, according to an embodiment of the disclosure;

[0011] Figure 6 is a schematic illustration of an example of a processing system which may be used to process data related to detection of a constituent or constituents via the leaching system, according to an embodiment of the disclosure;

[0012] Figure 7 is a schematic illustration of an example of the distributed fiber optic light system that may be used with a leaching system, such as the leaching system illustrated in Figure 1, according to an embodiment of the disclosure; and

[0013] Figure 8 is a schematic illustration of another example of a fiber optic light system combined with a flow cell, according to an embodiment of the disclosure.

DETAILED DESCRIPTION

[0014] In the following description, numerous details are set forth to provide an understanding of some embodiments of the present disclosure. However, it will be understood by those of ordinary skill in the art that the system and/or methodology may be practiced without these details and that numerous variations or modifications from the described embodiments may be possible.

[0015] The present disclosure generally relates to a unique system and methodology for utilizing light energy and fiber optic transmission of light in, for example, leaching operations. The light is used in-situ in combination with a flow cell and corresponding equipment to measure desired constituents, e.g. copper, in a fluid flow stream. In other words, the light is used at the source rather than in a laboratory or in a downstream location so as to enable rapid adjustment, e.g. real time adjustment, of the leaching processes. In situ refers to testing at the source where solutions are being applied rather than at downstream or laboratory locations. Additionally, the data obtained via the flow cell and corresponding equipment may be provided to a data processing system. The data processing system may be configured to automatically provide information, such as constituent concentration, within the flow stream. In many applications, the in-situ fiber optic transmission system and flow cell may be used in combination with the data processing system to provide real-time information on the flow stream. Depending on the application, the flow cells may have a variety of forms, including flow cells constructed with tubing, cuvetts, capillaries, sensors, and/or other suitable structures and devices.

[0016] According to an embodiment, a heap leaching operation is improved by obtaining real-time qualitative or quantitative information concerning distributed copper concentrations across the area or volume of the leach “lift” and this information may be utilized in the prediction and optimization of copper recovery. The present technique may be contrasted with conventional techniques which conduct monitoring at the discharge point of the leaching operation (e.g., via a toe collector) after the pore fluids

have been mixed and accumulated at the bottom of the heap over a period of time dictated by the fluid travel time through the heap. The present approach enables the collection and use of, for example, spatial and temporal information about copper (or other constituent) leaching performance in situ where solutions are being applied, e.g. across the top of the leaching lift. With many conventional systems, such information often is lost.

[0017] Embodiments described herein introduce various system and operational aspects that may be utile in overcoming the difficulties in obtaining a sufficient sample for analysis and for decreasing monitoring periodicity by, for example, measuring constituent, e.g. copper, concentrations directly in the leached ore instead of in the mine or offsite laboratory. According to an embodiment, a light source may be continuously directed through a pore fluid sample with a fiber optic cable that may be buried in the lift. The light may be transmitted into a small volume flow through a sampler that may continuously induce flow across the light path. In some applications, the flow of fluid may be induced by a vacuum pump and/or other motive force at the surface. Additionally, the flow of fluid may be induced via osmotic gradients established by desiccants (such as silica gel, anhydrite, and/or other salts) or via continuous capillary flow to a sink at a constant potential due to a lower pressure head than at the location of a flow cell, e.g. sensor, used to detect the constituent.

[0018] The desired constituent, e.g. copper, within the flow of fluid may be detected by a variety of techniques and detectors. For example, spectrophotometry may be utilized to determine the characteristic color in wastewater discharges (*e.g.*, Standard Methods for the Examination of Water and Wastewater, Method 2120C). Color in wastewater may result from the presence of natural metallic ions (*e.g.*, iron and manganese), humus and peat materials, plankton, bacteria, and components of industrial waste (among other factors). Color may be removed to make water suitable for general and industrial applications. In addition, color removal may be performed on industrial wastewater before discharge into watercourses.

[0019] Cupric copper (Cu^{+2}) in aqueous solutions is detectable visually by its distinctive blue color. In copper mining process solutions, the color may range from dark blue in the concentrated copper solutions, to bluish-green or green in processed leach solution returns (*e.g.*, raffinate) as a result of mixed copper and iron bearing solutions. However, spectrophotometric techniques may be utilized for detecting a variety of metals or other dissolved constituents in an aqueous or non-aqueous solution generated by a hydrometallurgical process. Furthermore, pH and other bulk properties of the solution may be detected via suitable detection systems with the addition of indicator components.

[0020] The detection of the desired constituent within the fluid may be obtained via spectrophotometry which can be performed in the field and installed as an in-line system for use during the leaching operation. An example of a suitable spectrometer is the USB 4000-UV-VIS Miniature Fiber Optic Spectrometer available from Ocean Optics. In a specific embodiment, an in-situ system as described in greater detail below may be used for monitoring of copper concentration in solution by ultraviolet-visible light (UV-Vis) infrared absorption spectroscopy. Real-time sensing of copper (or other constituents) in leaching operations may be utilized according to various applications. Examples of such applications include the first application of leach solution to an ore material in a vat leaching system, in a pad leaching system, in a heap and dump leaching system, and/or in other suitable systems. An example is a mining system employing a heap/dump leaching operation for recovery of copper.

[0021] Referring generally to Figure 1, an example of a leaching system 20 is illustrated. In this embodiment, leaching system 20 may be used for the continuous and/or distributed monitoring of copper in leach solutions. However, system 20 may be used for obtaining information regarding various other constituents contained within a fluid flow resulting from a leaching operation. The information may be used, for example, to assist mine operators and metallurgists in determining optimal operating conditions for these systems and/or to facilitate maintenance of desired solution processing efficiency.

[0022] In the embodiment illustrated in Figure 1, the leaching system 20 comprises a heap leaching system 22 having an active heap 24 which may be an active heap leach ore lift. In this example, the leaching system 20 further comprises a leach solution application 26 having a leach solution 28 which propagates down through the active heap 24. A constituent monitoring system 30, e.g. a copper monitoring system, is positioned along a midsection 32 or top section 34 of the active heap 24 to monitor the leaching solution 28 in situ for the presence of the desired constituent in the leach solution 28 at the source where solutions are being applied. The top section 34 is in the upper half of the vertical extent of the active heap 24. As explained in greater detail below, the monitoring system 30 may comprise a fiber optic system 36 having a fiber optic cable 38 buried in the active heap/lift 24. The leach solution 28 flows down through the monitoring system 30 to a lower section or toe drain 40 and then flows out of the active heap 24. In the specific example illustrated, the midsection 32 comprises spent ore from a previously leached portion 42 of the lift 24.

[0023] Referring generally to Figure 2, an embodiment of the monitoring system 30 is illustrated as comprising fiber optic system 36 coupled with a control system 44. In this example, the leach solution 28, e.g. percolating copper leach solution, flows down through the active heap/lift 24 and past a plurality of flow cells 46. In this example, flow cells 46 are in the form of flow-through detection cells 46 which are constructed to allow fluid, e.g. leach solution 28, to flow through each cell 46. While the leach solution 28 flows through the flow cells 46, light energy is transmitted through the flow cells 46 via fiber optic cable or cables 38 of fiber optic system 36. The light moving through each flow cell 46 is affected by the constituents in the leach solution 28 and the resulting changes are detected via a detection system 48 having a detector 50, such as a spectrophotometer. In this example, light energy spectroscopy is applied for monitoring the leach solution 28. In some applications, the detection system 48 also is configured to output the light signal which is directed along the optical fibers of the fiber optic cable or cables 38 and through the corresponding flow cells 46. The data obtained from detection system 48 is provided to control system 44 for analysis, e.g. to determine the concentration of copper and/or other constituents in the leach solution 28.

[0024] In some applications, the leaching system 20 may be utile in solvent extraction electrowinning (SX-EW) copper production systems. However, one or more aspects of the embodiments described herein may be utile in any other implementations, including analysis of a chemical species dissolved or held in a fluid. For example, embodiments described herein may be utilized to determine chemical species dissolved in water held in soil that may be contaminated from a hazardous chemical spill, in a downhole application associated with oil/gas exploration and/or production, and/or in various other implementations.

[0025] In mobile applications and other applications, the leaching system 20 may utilize detectors 50 in the form of portable spectrophotometry units, fiber optic transmission of light, micro-sized flow-cell design and construction materials, and/or subsurface pore water collection systems in variably saturated media. Such aspects render the monitoring equipment simple to operate relative to existing techniques and reduce monitoring costs. Data interpretation and processing also may be relatively straightforward for one or more implementations. By way of example, control system 44 may comprise a data processing system, such as a computer-based data processing system to provide rapid and inexpensive analysis of collected data. In many applications, the collection of data and analysis of that data may be conducted in real time while monitoring occurs in situ.

[0026] The determination of copper concentration in solution, or other constituent concentration, may be performed according to existing methods or methods developed in the future related to light absorption spectroscopy. Referring generally to Figure 3, an example is provided to illustrate the operation of a given flow cell 46. As illustrated, a beam of collated light 52 is passed through a transmissive fluid media, e.g. leach solution 28, within the flow cell 46. The beam of collated light 52 is at a known initial intensity and generated by a light emitter 54 which may be part of the detection system 48.

[0027] The detection system 48, e.g. spectrophotometer 50, is then used to measure the intensity of the light along a continuum of wavelengths after passing through the transmissive fluid media, as represented by arrow 56. As illustrated, the beam of collated light 52 is affected by constituents 58, e.g. eclipsed copper species, within the leach solution 28 and this causes secondary light scattering 60 which results in the exit light represented by arrow 56. It should be noted the collated light 52 may undergo a primary light scattering 61 as it enters flow cell 46 as indicated. The light 56 which exits the flow cell 46 is received, in this example, by detector/spectrophotometer 50. The data from spectrophotometer 50 may then be transmitted to the control system 44 for further analysis.

[0028] The intensities of each detected frequency may be compiled as a spectrum. Dissolved elemental species in solution have specific absorption frequencies as a result of scattering interactions with light. The relative absorption can be related to the concentration of the dissolved element through the Beer-Lambert law, set forth below as Equation (1):

$$A = -\log\left(\frac{I_s}{I_0}\right) = \varepsilon \cdot c \cdot L \quad (1)$$

where A is the measured absorbance, I_0 is the intensity of the incident light at a given wavelength, I_s is the transmitted intensity, c the concentration of the absorbing species, and L the path length through the sample. For each species and wavelength, ε is a constant known as the molar absorptivity or extinction coefficient, which is a molecular property in a given solvent at a particular temperature and pressure having units of $1 / M \cdot \text{cm}$ or $\text{AU} / M \cdot \text{cm}$. The absorbance A and the extinction coefficient ε may be defined in terms of the natural logarithm instead of the base 10 logarithm.

[0029] The Beer-Lambert law may be useful for characterizing many compounds. In some applications, however, the Beer-Lambert law may not hold as a universal relationship for the concentration and absorption of all substances so other appropriate

laws relationships may be utilized. For example, UV/Vis spectroscopy may be utilized in the quantitative determination of solutions of transition metal ions, such as copper and iron, and highly conjugated organic compounds. As described above, this same technology may be utilized for a solution containing a dissolved species that absorbs light of selected frequencies. Examples of other mineral commodities that may be processed by hydrometallurgical techniques that may benefit from real-time, spatially-distributed concentration analysis according to one or more aspects of the present disclosure may include, gold, silver, manganese, chromium, cobalt, uranium, and/or one or more associated byproducts. Selected hydrometallurgical process systems described herein may be used to accommodate such applications.

[0030] As described above, the methodology for analyzing selected constituents 58 within various solutions 28 may be implemented by leaching system 20 having the flow cell 46, or a string of flow cells 46, connected to a fiber optic cable 38. The flow cell 46 (or cells) and corresponding fiber optic cable 38 (and/or another suitable cable) may be buried in copper heap leach ore material to a desired depth. The distance from one flow cell 46 to the next may determine the spatial resolution for determining copper concentrations in the pore fluid. Light from an external or internal source with respect to the flow cell 46 may be directed at and/or through the flow cell 46. A pressure gradient may be induced across the flow cell 46 to cause pore fluid within the heap 24 to flow into the cell 46. The light that passes through the flow cell 46 may be absorbed, and the intensity attenuation may be measured by the detector/spectrometer 50 attached to the outlet portion of fiber optic cable 38.

[0031] The monitoring system 30 may comprise a variety of components depending on the parameters of a given application. For example, the detection system 48 may comprise a multichannel spectrophotometer 50 and/or other detector, such as the USB4000-UV-VIS miniature fiber optic spectrometer, available from OCEAN OPTICS, INC. However, other types of detectors 50 may be used in certain applications. The monitoring system 30 also may comprise various types of light sources, such as those in the UV-VIS wavelength range. Additionally, monitoring system 30 may comprise one or

more sheathed fiber optic lines 38 or other suitable light transmission lines 38 which enable incident transmitted light distribution to flow through one or more cells 46 and/or for relay of transmitted light back to the one or more detectors, e.g. spectrophotometer 50. The flow cell 46 also may comprise various leach solution containing elements 62, as illustrated in Figure 4. Examples of elements 62 comprise various sample cell cuvettes, flow-through cells, capillary media, tubes, and/or other elements selected according to the parameters of the specific application. Additional examples of elements 62 include one or more micro-sized flow-through cells and flow cells having one or more acid and/or chemical-resistant windows (e.g. windows comprising sapphire) and/or light-transmissive capillary media. As described in greater detail below, the flow cells 46 also may be instructed as or with sensors.

[0032] As further illustrated in Figure 4, monitoring system 30 also may comprise a flow induction mechanism 64 which facilitates flow of the leaching solution 28 through the flow cell 46. By way of example, flow induction mechanism 64 may comprise one or more microlysimeters, such as those including at least one filter candle and/or at least one filter membrane. The flow induction mechanism 64 also may comprise various vacuum sources and/or desiccants to facilitate flow induction through the sample cell(s) 46. Depending on the application, the microlysimeters may comprise fluid catchments and/or containers and/or filter candles, such as filter candles formed of porous ceramic material or other suitable materials. The selected materials effectively exclude sediments and/or suspended solid matter in the analyzed fluid. The flow induction mechanism 64 also may comprise a suction pump or may utilize a moisture or osmotic potential differential induced by silica gel, an anhydrite or salt block, and/or a moisture wick to atmosphere.

[0033] In general, the monitoring system 30 also may comprise one or more signal processors, e.g. signal processors in which the signal gain/amplitude/other characteristics may be integrated with the detector system 48. Implementations of monitoring system 30 also may comprise and/or utilize one or more computer processors and/or software, e.g. control system 44, operable for signal decoding and/or

quantification, and/or one or more calibration algorithms for wavelength(s) of interest and/or standard solutions.

[0034] Depending on the application, the leach solution 28 may comprise a variety of materials. For example, sulfuric acid is a useful lixiviant for copper solution mining systems, and the principal components of certain loaded leach solutions may be or may comprise copper and/or sulfate. For copper sulfate solutions, standard solutions may be made utilizing reagent grade chemicals. A solution set may comprise copper sulfate in solution at varying strengths. More complex deconvolution of signals may utilize the addition of ferrous and/or ferric sulfate so as to simulate the background of leaching solutions. Chemometric techniques, e.g. factor analysis, may be utilized to resolve matrix interference effects from multiple dissolved and/or suspended fluid species. A non-limiting example of a calibration matrix for concentration ranges applicable to solution mining of copper ores is set forth below in table provided in Figure 5.

[0035] Referring generally to Figure 6, an example of a data processing control system 44 is illustrated. It should be noted that portions of the data processing control system 44 may be integrated with other components of the monitoring system 30, such as the detector/spectrophotometer 50. Figure 6 provides a block diagram of an example processing system 66 that may execute machine-readable instructions to implement aspects of the methods and/or processes described herein. For example, the processing system 66 may be utilized in providing controlled for the monitoring system 30, e.g. a heap leach field monitoring system. In some applications, the processing system 66 may be at least partially implemented in surface equipment, detection system 48, and/or other components of the overall system 20.

[0036] Depending on the application, the data processing control system 44 may comprise one or more processors, controllers, special-purpose computing devices, servers, personal computers, personal digital assistant (PDA) devices, smartphones, internet appliances, and/or other types of computing devices. In the example illustrated in Figure 5, the processing system 66 of overall data processing control system 44

comprises a processor 68 such as, for example, a general-purpose programmable processor. The processor 68 may comprise a local memory 70 and may be configured to execute coded instructions 72 present in the local memory 70 and/or in another memory device.

[0037] The processor 68 may execute machine-readable instructions, or other data inputs, to implement the methods and/or processes described herein. The processor 68 may comprise various types of processing units, such as one or more INTEL™ microprocessors, one or more microcontrollers from the ARM and/or PICO families of microcontrollers, one or more embedded soft/hard processors in one or more field-programmable gate arrays (FPGAs) or other suitable devices. In some applications, other processors from other families also may be appropriate.

[0038] The processor 68 may be in communication with a main memory, e.g. a volatile (*e.g.*, random access) memory 74 and/or a non-volatile (*e.g.*, read-only) memory 76, via a bus 78. The volatile memory 74 may comprise static random access memory (SRAM), synchronous dynamic random access memory (SDRAM), dynamic random access memory (DRAM), RAMBUS dynamic random access memory (RDRAM), and/or other types of random access memory devices. Similarly, the non-volatile memory 76 may comprise flash memory and/or other desired types of suitable memory devices. One or more memory controllers (not shown) may control access to the main memory 74 and/or 76.

[0039] As further illustrated, the data processing system 44 also may comprise an interface circuit 80. The interface circuit 80 may utilize various types of interface standards, such as an Ethernet interface, a universal serial bus (USB), a third generation input/output (3GIO) interface, and/or other suitable devices/standards. One or more input devices 82 may be connected to the interface circuit 80. The input device(s) 82 may be configured to permit a user to enter data and/or commands into the processor 68. The input device(s) 82 may comprise, for example, a keyboard, a mouse, a touchscreen, a

track-pad, a trackball, an isopoint, a voice recognition system, and/or other suitable input devices.

[0040] Additionally, one or more output devices 84 also may be connected to the interface circuit 80. The output devices 84 may comprise, for example, display devices (*e.g.*, a liquid crystal display and/or cathode ray tube display), printers, speakers, and/or other suitable output devices. Thus, the interface circuit 80 also may comprise a graphics driver card. Furthermore, the interface circuit 80 may comprise a communication device, such as a modem, network interface card, and/or other device facilitating exchange of data with external computers via a network (*e.g.*, Ethernet connection, digital subscriber line (DSL), telephone line, coaxial cable, cellular telephone system, satellite).

[0041] The data processing system 44 also may comprise one or more mass storage devices 86, *e.g.* storage devices for storing machine-readable instructions and/or data. Examples of such mass storage devices 86 include floppy disk drives, hard drive disks, compact disk drives, digital versatile disk (DVD) drives, and/or other suitable mass storage devices. The coded instructions 72 may be stored in the mass storage device 86, the volatile memory 74, the non-volatile memory 76, the local memory 70, and/or on a removable storage medium, such as a CD or DVD 88. In some applications, the control system 44 and/or data processing capability may be embedded in whole or in part in a structure such as a processor and/or an ASIC (application specific integrated circuit).

[0042] As described herein, embodiments of the system 20 provide a method of using light energy (ultraviolet, visible, and/or infrared) spectroscopy and fiber optic transmission of light for measuring copper and/or other metal and/or non-metal concentrations in-situ within an operation employing a leach system, *e.g.* a heap leach operation. However, the monitoring system 30 of a system 20 may be utilized in other monitoring and analyzing applications, such as another solution mining unit, an associated conveyance system, and/or other fluid analysis applications in which a fluid analysis is performed at the source. In leaching systems and certain other systems 20, the monitoring occurs as fluid moves through a porous material, *e.g.* as leach solution 28

moves through the porous material of the lift 24 in a heap leach system. The detected species may comprise at least one of: copper; one or more precious metals (such as gold and/or silver, among others); base metals (such as iron, zinc, and/or cobalt, among others); uranium; pH; bacteria; color; and/or other aqueous or non-aqueous species that produces an absorbance spectra when illuminated with light energy.

[0043] The monitoring system 30 utilizes a flow cell or flow cells 46 which are operable to conduct one or more pore fluids from a saturated or unsaturated media; through a filter media to, for example, exclude suspended solids interferences; and into a light path. The light path is provided by fiber optic system 36 and the light path may be conducted by a fiber optic and/or other cable 38 for determination of absorbance spectra. The flow of fluid through or along the flow cell(s) 46 may be induced utilizing an active or passive mechanism 64, thus providing a method for altering gradients, e.g. a method that may utilize capillary rise into the light path of a sensor. Other active and/or passive mechanisms 64 may be configured for inducing the flow via pressure induced gradients, moisture induced gradients, temperature induced gradients, and/or osmotic induced gradients. The embodiments described herein may be used to promote flow from a pore space of the media into a flow cell and a sink such that the concentration of the species in the pore solution can be tracked over specified intervals of time by adjustment of the residence time in the flow cell(s) 46.

[0044] Additionally, the system 20 and its monitoring system 30 provide a method of calibration that utilizes relative indexing of process solutions which are contained within a leaching operation or conveyance infrastructure. One, two, or more calibration curves may be developed from internal reference solutions, such that intermediately evolved copper concentrations (or other constituent concentrations) along a flow path and/or over time may be estimated as a percentage and/or fraction of the calibration solutions. At least one internal calibration solution concentration may be determined by duplicate analysis, e.g. periodic analysis; by one or more external laboratories; and/or by one or more quantitative methods, e.g. by collecting one or more samples from an accessible inlet and/or outlet station. One or more concentrations may

be estimated via application of the calibration constants, polynomial fitting, and/or other chemometric techniques. Examples of such techniques comprise principal component analysis (PCA) and/or factor analysis to subtract effects of one or more interferences, such as the effects of dissolved iron as illustrated in the table of Figure 5.

[0045] In various applications, the data processing control system 44 is operable to render raw absorbance spectra transmitted by one or more fiber optic and/or other cables 38 to a signal and/or data processing system, e.g. processing system 66 of overall data processing control system 44. The processing system 66 may utilize a calibration methodology according to one or more aspects of the embodiments described herein and/or one or more chemometric techniques to render a quantifiable copper and/or other constituent concentration. The concentration may be determined and displayed in real-time on a suitable output device 84, such as a computer screen or other display. The concentration data related to species 58 within leach solution 28 may be analyzed automatically via data processing control system 44 and/or may be provided for operator interpretation, as illustrated in the embodiment of Figure 7.

[0046] Referring again to the embodiment of Figure 7, an individual flow cell 46 or often a plurality of the flow cells 46 may comprise sensing devices 90 arranged in a grid throughout the heap 24. By way of example, the sensing devices 90 may comprise transparent capillary tubes 92 integrated with the optical cable/fibers 38 and arranged along a microlysometer tray 94. In this example, one or more interpretive geostatistical algorithms may be utilized to interpolate one or more concentrations (e.g. concentrations for copper) between sensors 90. An output may be displayed to an operator via output device 84. Examples of such an output include: a data array/table of copper and/or one or more other concentrations; a single and/or multiple sensor time series concentration of copper and/or one or more other concentrations; a two-dimensional and/or other cross-sectional display along a sensor string array or linking multiple arrays at sensor intercepts that show copper and/or other constituent gradients as contours, grey scale, other color schemes, and/or cloud diagrams, among other formats; a three-dimensional isocon display showing the copper and/or other constituent concentration gradients

superimposed on a leach solution plume distribution; and/or other suitable types of rendered and/or processed data displays utilizing geodata visualization techniques and/or graphics, e.g. PETREL and SURFER visualization software available from Schlumberger Corporation.

[0047] In embodiments described herein, the data processing control system 44 comprises suitable software modules, such as a data processing operator management system 96, that may be utilized with an optical fiber/cable 38 and light absorbance flow cells 46 which transmit incident light energy through a transparent capillary media having pore spaces which are simultaneously filled and/or partially filled with leach solution 28. However, some applications may utilize other media exhibiting total internal reflection along one or more axes of symmetry, e.g. ULEXITE.

[0048] Referring generally to Figure 8, an example of a transparent capillary media 98 is illustrated as comprising flow cell 46 packed with micro hollow glass spheres 100, such as those manufactured by 3M for lightweight cement applications. In an operational example, copper and/or other metal bearing solution 28 may flow by capillary action along the pore spaces/interstices 102 of the flow cell 46 between the surfaces of the hollow glass spheres 100. The light 52 is therefore limited to passing through the surface film of solution that is held by surface tension along the glass or other surface of the spheres 100.

[0049] Light energy may be absorbed by dissolved copper and/or other constituent species 58 in the capillary fluid film held by surface tension between the spheres 100. Light 52 entering the spheres 100 may pass through and exit the other surface of the sphere where it may intercept another film of leach solution 28 that enters the flow cell 46. The light may exit the flow cell 46, as indicated by arrow 56, and may be transmitted to a signal-processing unit, e.g. detection system 48, by one or more fiber optic and/or other light transmission cables 38.

[0050] By calibration against one or more reference solutions, the signal and/or data processing system may be utilized to compensate for the integral effects of multiple absorption paths through each capillary layer. A compensation for the path light reduction by the hollow spheres 100 is improved as compared to the traditional Beer-Lambert law theory. The degree of saturation also may be determined by advanced signal processing utilizing, for example, a known concentration and/or independent water content measurement and/or calibration against known solution application rates and average degrees of saturation within the ore media. This calibration may be performed on data processing system 44 and may be utilized to estimate the average path length of light passing through the capillary flow cell 46.

[0051] In a variety of applications, the detection system 48 may be used for detection of one or more dissolved chemical species 58 in solution that enter one or more flow cells 46 with no or undetectable absorbance. However, the absorbance may be induced by another chemical agent that complexes with the target species for detection, thus generating a chemical complex which is detected by light spectroscopy according to, for example, embodiments described above utilizing spectrophotometer 50.

[0052] An indicator agent may be added to flow cell(s) 46 directly and/or just prior to entry of the fluid 28 into the flow cell and light path. Examples of adding the indicator agent include: injection via a tubular line and/or port attached to the flow cell; diffusion and/or metered flow from a reservoir attached to the flow cell; chemical gradient flow from an exchange cartridge attached to the flow cell; and other suitable techniques for releasing the indicator agent to the flow cell 46 containing the target solution. In some applications, the detection system 48 may be used to detect one or more dissolved chemical species in solution that have been chromatographically separated from interfering species by flow through an ion exchange column.

[0053] Accordingly, embodiments described herein may be used in many types of applications and configurations. Examples include a method of using light energy spectroscopy and fiber optic transmission of light to measure metals, e.g. copper and/or

non-metal concentrations in situ. The light energy may be ultraviolet light, visible light, and/or infrared light. Additionally, the methodology to be used within a heap leach operation, within other solution mining units, in other associated conveyance systems, and/or in systems in which fluid analysis is performed at the source. By way of example, the constituents/species detected may be copper, precious metals, e.g. gold or silver, base metals, e.g. iron, zinc, cobalt, uranium, pH, bacteria, color, and/or other aqueous or non-aqueous species that produce an absorbance spectra when illuminated with light energy.

[0054] Certain embodiments of system 20 utilize at least one flow cell in which each flow cell is operable to conduct pore fluids from a saturated or unsaturated media through a filter media, e.g. a filter media positioned to exclude suspended solids interferences. The pore fluids are conducted into a light path established through a fiber optic cable or other suitable medium to enable determination of absorbance spectra. In some applications, flow may be induced through each flow cell by active or passive techniques. Examples of such techniques include using a capillary to cause the fluid to rise into the light path of a sensor. However the techniques also may utilize pressure induced gradients, moisture induced gradients, temperature induced gradients, and/or osmotic induced gradients. Such flow induction mechanisms also may be used to promote flow from a pore space of a media into a flow cell and a sink such that the concentration of the species in the pore solution can be tracked over specified intervals of time by adjustment of the residence time in the flow cell.

[0055] Embodiments of system 20 also may be used in providing methods of calibration which utilize relative indexing of process solutions that are contained within a leaching operation or other fluid conveyance infrastructure. According to an example implementation, one, two, or more calibration curves may be determined from internal reference solutions such that immediately evolved copper concentrations along a flow path and/or over time may be estimated as a percentage/fraction of the calibration solutions. Additionally, one or more internal calibration solution concentrations may be determined by duplicate analysis, e.g. periodic analysis, via external laboratories and/or quantitative methods, e.g. collecting one or more samples from an accessible inlet and/or

outlet station. As referenced above, some implementations enable one or more concentrations to be estimated via application of calibration constants, polynomial fitting, and/or other chemometric techniques, e.g. principal component analysis (PCA) and/or factor analysis to subtract effects of interferences such as dissolved iron.

[0056] In some applications, embodiments of system 20 may utilize data processing system 44 which is operable to render raw absorbance spectra transmitted by at least one fiber optic cable or other suitable cable to a processing system. The processing system may utilize a calibration methodology according to selected characteristics and chemometric techniques to render a quantifiable copper and/or other constituent concentration. The concentration may be displayed in real time on a computer screen or other display output for operator interpretation.

[0057] In some operations, the grid of cells 46 may be in the form of a grid of sensors 90 deployed throughout the porous material, e.g. throughout a desired portion of the heap leach system. This further enables interpretive geostatistical algorithms to be utilized in interpolating concentrations between the flow cells 46/sensors 90. For example, concentrations of copper may be determined between the cells 46/sensors 90.

[0058] The flow cells 46 may utilize transparent capillary media pack of MICRA hollow glass spheres. In such applications, the copper and/or other metal bearing solution may flow by capillary action along the pore spaces and interstices of the flow cell along the surfaces of the hollow glass spheres. The light is thus limited to passage through the surface film of solution that is held by surface tension along the glass or other surface of the sphere. Light energy may be absorbed by dissolved copper and/or other constituent species in the capillary fluid film held by surface tension between the spheres. Light entering the spheres may pass through and exit the other surface of the sphere where it may intercept another film of leach solution that enters the cell. The light may exit the cell 46 and be transmitted to a signal processing unit of detection system 48 and/or data processing control system 44 by one or more fiber optic cables or other suitable cables 38. By calibration against one or more reference solutions, the signal

and/or data processing system may be utilized to compensate for the integral effects of multiple absorption paths through each capillary layer. A compensation for the path light reduction by the hollow sphere is thus possible. The degree of saturation may be determined by advanced signal processing utilizing, for example, a known concentration and/or independent water content measurement and/or calibration against known solution application rates and average degrees of saturation within the ore media. This calibration may be utilized to estimate the average path length of light passing through the capillary flow cell.

[0059] Embodiments of system 20 facilitate detection of one or more dissolved chemical species in solution that enter one or more cells 46 with no or undetectable absorbance, but whose absorbance is induced by another chemical agent that complexes with the target species for detection, generating a chemical complex that is detected by light spectroscopy as described above. In some applications, an indicator agent is added to a flow cell 46 directly and/or just prior to entry into the flow cell detector and light path. The addition of another chemical agent may be according to injection via a tubular line and/or port attached to the flow cell; diffusion and/or metered flow from a reservoir attached to the flow cell; chemical gradient flow from an exchange cartridge attached to the flow cell; and/or other mechanisms for releasing the indicator agent to the flow cell 46 containing the target solution. Certain embodiments also facilitate detection of dissolved chemical species in solution that have been chromatically separated from interfering species by flow through an ion exchange column attached to, for example, the sensor 90.

[0060] The embodiments described above facilitate analysis of various species within a variety of solutions. The embodiments are useful in several types of leaching operations, such as operations utilizing heap leach systems. The embodiments described herein may be positioned at various locations throughout the heap to facilitate more accurate analysis of species, e.g. copper, within the leach solution. The overall system also enables real time analysis of the flowing leach solution.

[0061] Depending on the parameters of a given application, however, the overall system 20 may be arranged in a variety of configurations. For example, the flow cells 46/sensors 90 may be positioned in many types of grid patterns and with many different numbers to facilitate analysis of fluids throughout the overall system. Additionally, the detection systems may utilize spectrophotometers 50 or other types of detectors for detecting the presence of the desired species, e.g. copper. Similarly, many types of data processing control systems 44 may be utilized with various software modules to enable the desired analysis of data collected via the flow cells 46.

[0062] Although a few embodiments of the disclosure have been described in detail above, those of ordinary skill in the art will readily appreciate that many modifications are possible without materially departing from the teachings of this disclosure. Accordingly, such modifications are intended to be included within the scope of this disclosure.

CLAIMS

What is claimed is:

1. A method for monitoring species in a fluid flow, comprising:
establishing a flow of leach solution in a leaching system;
locating a flow cell in situ within the leaching system at a source where the leach solution is being applied so the flow cell receives samples of leach solution from the flow of leach solution in the leaching system;
transmitting light energy through the flow cell and through the leach solution in the flow cell;
using spectroscopy to evaluate the light energy passing through the leach solution in the flow cell; and
processing data resulting from the spectroscopy to determine concentration of a species in the leach solution.
2. The method as recited in claim 1, wherein establishing comprises establishing the flow down through a lift of a heap leach system.
3. The method as recited in claim 1, wherein locating comprises locating a plurality of the flow cells in the leach system.
4. The method as recited in claim 3, wherein transmitting light energy comprises delivering light energy through the plurality of flow cells via at least one fiber optic cable deployed in the leach system.
5. The method as recited in claim 4, wherein locating comprises locating the plurality of flow cells in a top portion of the lift.
6. The method as recited in claim 1, further comprising using a flow induction mechanism to induce the leach solution to flow through the flow cell.

7. The method as recited in claim 6, further comprising flowing leach solution through a pore space of a media in the flow cell such that the concentration of the species can be tracked over specified intervals of time by adjustment of a residence time in the flow cell.
8. The method as recited in claim 1, further comprising performing a calibration of the data obtained via the spectroscopy.
9. The method as recited in claim 1, wherein processing data comprises using a computer-based processing system coupled with a spectrophotometer.
10. The method as recited in claim 1, wherein locating the flow cell comprises locating a plurality of flow cells which comprise sensors.
11. The method as recited in claim 1, wherein processing data comprises processing data in real time during flow of the leach solution through the leach system.
12. A system, comprising:

a leach system having a plurality of flow cells disposed in situ within a leach solution in a pattern throughout a region through which the leach solution propagates, the plurality of flow cells being incorporated into a monitoring system which directs light through the plurality of flow cells and through the leach solution within the plurality of flow cells, the monitoring system further comprising a detector to detect a desired constituent within the leach solution in real time.
13. The system as recited in claim 12, wherein the region through which the leach solution propagates is a top portion of a lift of a heap leach system.
14. The system as recited in claim 12, further comprising a data processing control system coupled with the detector.
15. The system as recited in claim 14, wherein the detector comprises a spectrophotometer.

16. The system as recited in claim 15, wherein the light is directed along fiber optic cables.
17. The system as recited in claim 12, wherein the detector detects concentrations of copper in the leach solution.
18. A method, comprising:
 - locating a grid of cells throughout a system of porous material through which a fluid flows;
 - coupling the grid of cells with a fiber optic system;
 - transmitting light energy via the fiber optic system through the fluid which moves into the cells of the grid of cells; and
 - monitoring the fluid in situ and in real time for characteristic changes in the fluid to determine a concentration of a specific constituent in the fluid.
19. The method as recited in claim 18, wherein locating comprises locating the grid of cells in a heap leach system.
20. The method as recited in claim 18, further comprising flowing fluid through a pore space of a media in each cell such that the concentration of the species can be tracked over specified intervals of time by adjustment of a residence time in each cell within the grid of cells.

FIG. 1
1/4

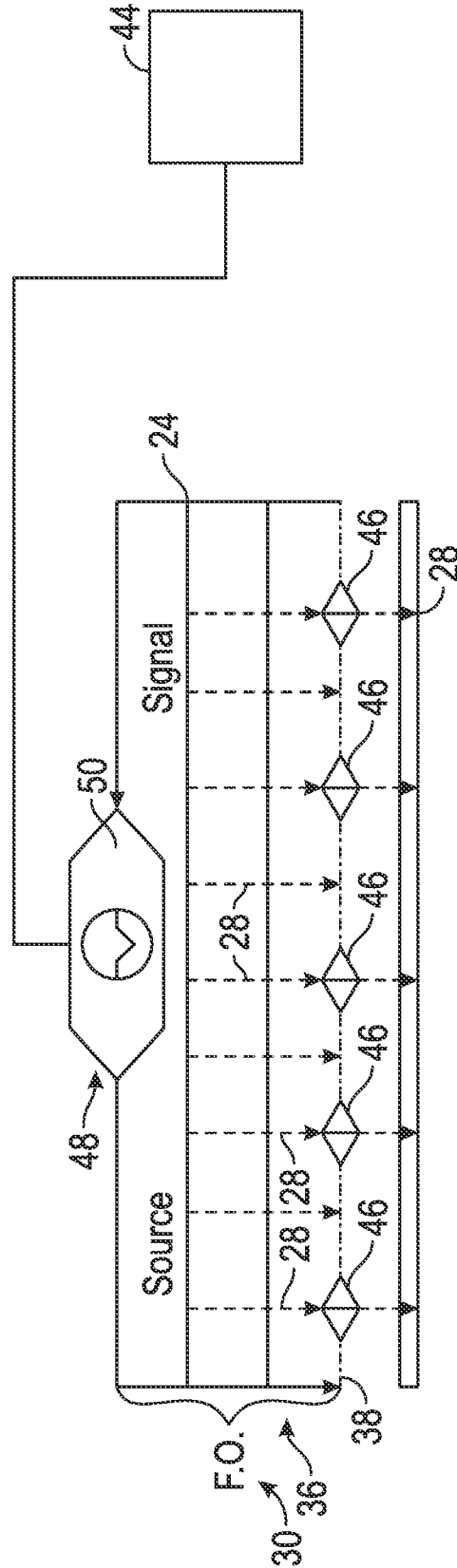
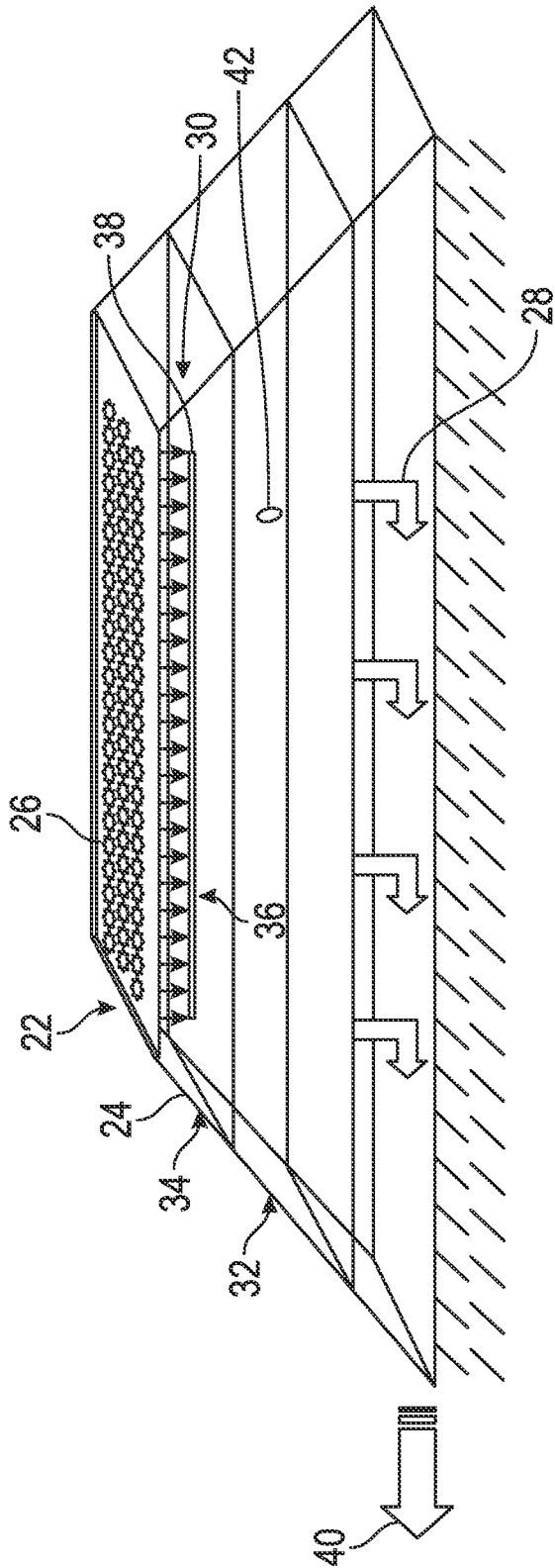

FIG. 2

2/4

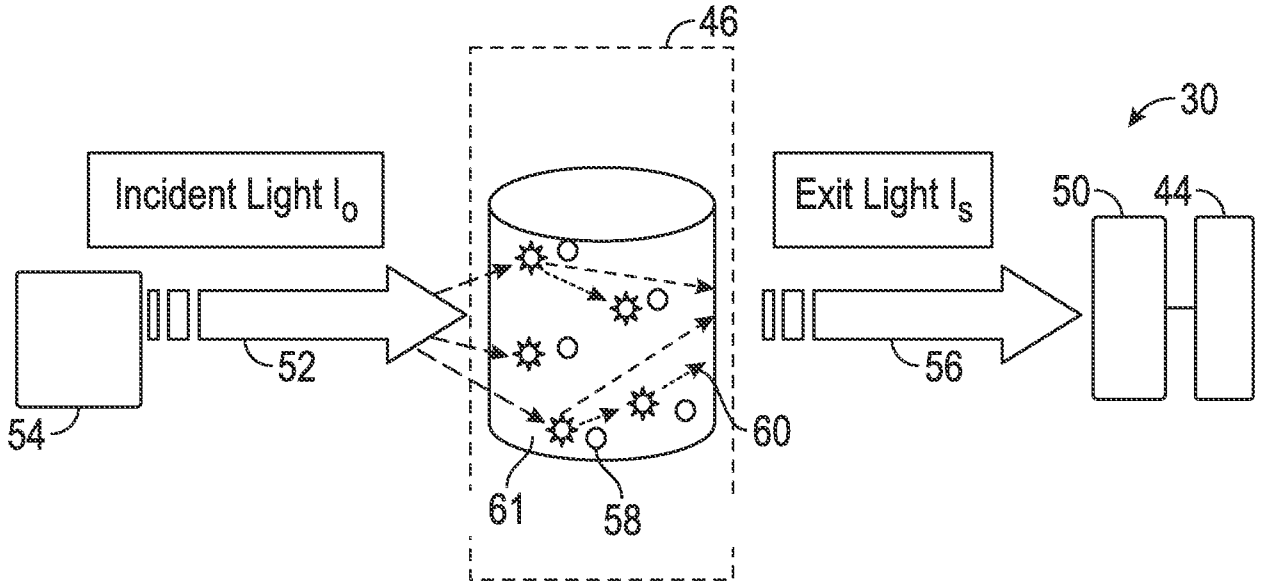

FIG. 3

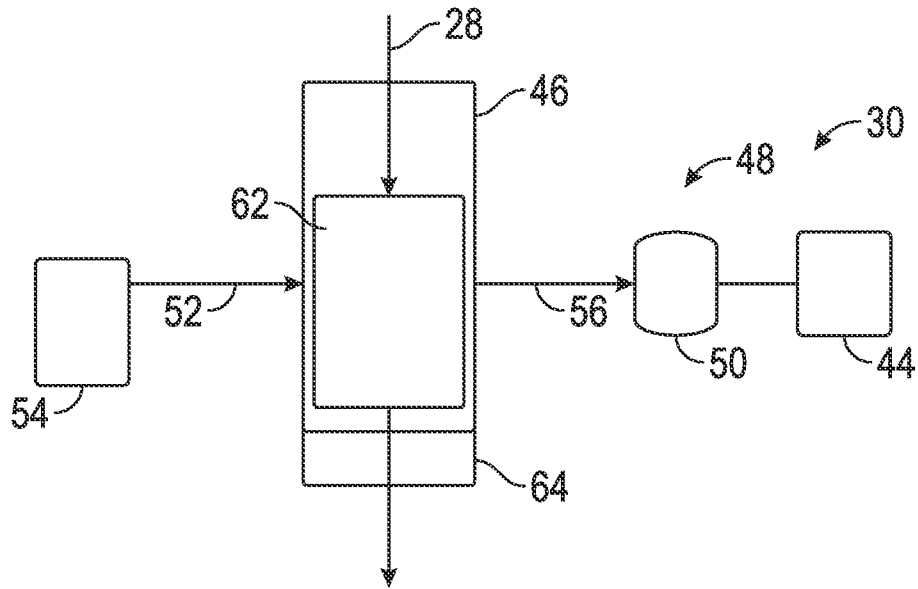

FIG. 4

3/4

CuSO ₄ (g/l)/ FeSO ₄ (g/l)	1	5	10	25
0	☑	☑	☑	☑
5	☑	☑	☑	☑
10	☑	☑	☑	☑
25	☑	☑	☑	☑

FIG. 5

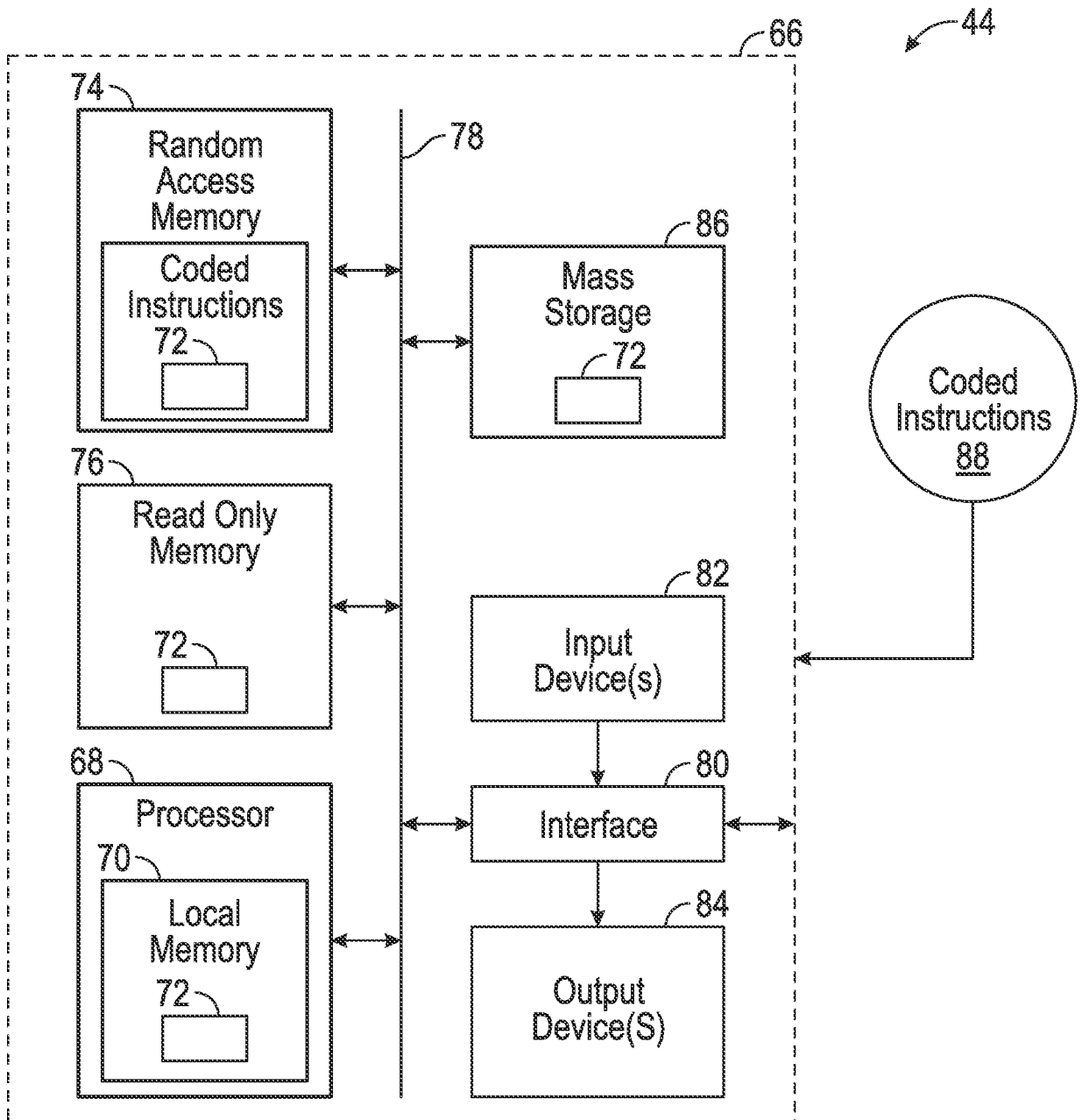

FIG. 6

