

AMENDED



623743

(CONVENTION. By one or more persons and/or a Company.)

Form 4

COMMONWEALTH OF AUSTRALIA
Patents Act 1952

CONVENTION APPLICATION FOR A PATENT

We CLIMBMINSTER LIMITED, of ^{4 Redgate Lane West Gorton} ~~28 Rosslyn Hill, Hampstead,~~
~~Manchester M12 4RY~~ ~~London NW3 1NH~~, UNITED KINGDOM, hereby apply for the grant of a Patent
for an invention entitled:

HANDBRUSH AND METHOD OF MANUFACTURING THEREOF

which is described in the accompanying complete specification. This application is a Convention application and is based on the applications numbered 89/1158 and 90/0718 for a patent or similar protection made in Republic of South Africa on 15th February, 1989, and 31st January, 1990.

Our address for service is WATERMARK Patent & Trade Mark Attorneys, of "THE ATRIUM", 2nd Floor, 290 Burwood Road, HAWTHORN, 3122, AUSTRALIA.

DATED this 9th of July, 1990.

CLIMBMINSTER LIMITED

By our Attorneys,

WATERMARK
Patent & Trade Mark Attorneys,

L. J. Dyson



To: THE COMMISSIONER OF PATENTS.

COMMONWEALTH OF AUSTRALIA

Patents Act 1952-1969

DECLARATION IN SUPPORT OF A CONVENTION APPLICATION FOR A PATENT OR PATENT OF ADDITION

(1) Here insert (in full) Name of Company.

In support of the Convention Application made by⁽¹⁾.....

CLIMBMINSTER LIMITED

(hereinafter referred to as the applicant) for a Patent

(2) Here insert title of Invention.

for an invention entitled:⁽²⁾.....

HANDBRUSH AND METHOD OF MANUFACTURE THEREOF

(3) Here insert full Name and Address, of Company official authorized to make declaration.

I,⁽³⁾ GERHARD ALBERTUS VAN NIEKERK

of: 4 Redgate Lane, West Gorton, MANCHESTER M12 4RY

UNITED KINGDOM

do solemnly and sincerely declare as follows:

1. I am authorised by the applicant for the patent to make this declaration on its behalf.

(4) Here insert basic Country or Countries followed by date or dates and basic Applicant or Applicants.

2. The basic applications as defined by Section 141 of the Act ~~was~~ were made in⁽⁴⁾ South Africa

on the 15th day of February 1989, by WONDERBROOM MARKETING CC and

on the 31st day of January 1990, by WONDERBROOM MARKETING CC

(5) Here insert (in full) Name and Address of Actual Inventor or Inventors.

3.⁽⁵⁾ GERHARD ALBERTUS VAN NIEKERK

4 Redgate Lane, West Gorton, MANCHESTER M12 4RY

UNITED KINGDOM

is/~~are~~ the actual inventor of the invention and the facts upon which the applicant is entitled to make the application are as follow:

The applicant is the assignee of GERHARD ALBERTUS VAN NIEKERK has assigned his invention to WONDERBROOM MARKETING CC and they in turn have assigned their interest to CLIMBMINSTER LIMITED

4. The basic application referred to in paragraph 2 of this Declaration was.....the first application made in a Convention country in respect of the invention the subject of the application.

DECLARED at Pretoria

this 13th day of August 1990

(6) Signature.

(6)

Gerhard Albertus van Niekerk

To: THE COMMISSIONER OF PATENTS.

(12) PATENT ABRIDGMENT (11) Document No. AU-B-49813/90
(19) AUSTRALIAN PATENT OFFICE (10) Acceptance No. 623743

(54) Title
HANDBRUSH AND METHOD OF MANUFACTURE THEREOF

International Patent Classification(s)
(51)⁵ **A46B 001/00 A46B 015/00**

(21) Application No. : **49813/90**

(22) Application Date : **15.02.90**

(30) Priority Data

(31) Number	(32) Date	(33) Country
89/1158	15.02.89	ZA SOUTH AFRICA
90/0718	31.01.90	ZA SOUTH AFRICA

(43) Publication Date : **23.08.90**

(44) Publication Date of Accepted Application : **21.05.92**

(71) Applicant(s)
CLIMBMINSTER LIMITED

(72) Inventor(s)
GERHARD ALBERTUS VAN NIEKERK

(74) Attorney or Agent
WATERMARK PATENT & TRADEMARK ATTORNEYS , Locked Bag 5, HAWTHORN VIC 3122

(56) Prior Art Documents
AU 81674/82 A46B 1/00

(57) Claim

1. A method of manufacturing a handbrush comprising a head, a handle connected to the head and bristles projecting from the head, including the steps of
 - moulding the head, the handle and the bristles as one integral part from a polymeric compound; and
 - embedding in the head and the handle a rigid strengthening member.
2. A handbrush comprising a head, a handle connected to the head and a plurality of bristles projecting from the head, in which the head, the handle and the bristles are all integrally moulded in one piece from a polymeric compound and in which a rigid strengthening member is embedded in the head and the handle.

623743

Form 10

COMMONWEALTH OF AUSTRALIA

PATENTS ACT 1952-69

COMPLETE SPECIFICATION

(ORIGINAL)

Class

Int. Class

Application Number:

Lodged:

Complete Specification Lodged:

Accepted:

Published:

Priority:

Related Art:

Name of Applicant:

~~CLIMBMINSTER LIMITED~~ CLIMBMINSTER LIMITED

Address of Applicant:

4 Redgate Lane West Gorton
~~28 Rosslyn Hill, Hampstead, London NW3 1NH, United Kingdom~~
Manchester M12 4RY United Kingdom

Actual Inventor:

GERHARD ALBERTUS VAN NIEKERK

Address for Service:

WATERMARK PATENT & TRADEMARK ATTORNEYS.
LOCKED BAG NO. 5, HAWTHORN, VICTORIA 3122, AUSTRALIA

Complete Specification for the invention entitled:

HANDBRUSH AND METHOD OF MANUFACTURE THEREOF

The following statement is a full description of this invention, including the best method of performing it known to :- US



THIS INVENTION relates to a handbrush and to a method for the manufacture thereof.

Various kinds of handbrushes have been used by mankind over many centuries. Still the most commonly known brushes today are those that comprise an elongate head to one end of which is attached a handle, the head comprising a plurality of bristles bound in bundles, each bundle being fixed in a hole provided in the head. The means of fixing could, for instance, include dipping
10 of the bristles in lacquer, pitch or another binding agent and introduction thereof into the holes, or alternatively, by means of staples or the like.

To be able to market handbrushes at acceptable prices, either low-cost labour or else, capital intensive automatic or semi-automatic machines are employed, the latter of which produces large numbers of brushes of the aforementioned kind. However, a disadvantage of such conventional brushes comprising separate bristles is that the bristles are often dislodged from the holes in
20 which they are fixed, especially in the case of brushes of which the heads are made of wood, and where such heads are intermittently used with water, causing the head to swell and contract repeatedly. Other brushes exist in which the head and the bristles are made of plastics materials, with the head having a plurality of receptacles for receiving the bundles of bristles. The bristles of such brushes are usually fixed by heating and subsequent solidification of the plastics material of the head around the bristles.

30 It is an object of the present invention to provide a handbrush and a method for the manufacture thereof, which comprises the minimum number of separate constituent parts.

It is a further object of the invention to provide a handbrush which can be used not only to brush dry surfaces such as upholstery, carpets, clothing and the like, but also to assist in washing objects such as the exterior painted surfaces of a motor vehicle without scratching, or other sensitive objects such as cutlery, crockery, glassware and the like.

10 It is another object of the invention to provide a single tool for brushing dry surfaces, for washing wet surfaces and for removing water from glass surfaces.

Further objects and advantages of the invention will become apparent from a reading of the specification together with the attached drawings.

According to the invention, there is provided a method of manufacturing a handbrush comprising a head, a handle connected to the head and bristles projecting from the head, including the steps of moulding the head, the handle and the bristles as one integral piece from a polymeric compound; and embedding during or after the
20 moulding process, a rigid strengthening member in the head and the handle.

Also according to the invention, there is provided a handbrush comprising a head, a handle connected to the head and a plurality of bristles projecting from the head, in which the head, the bristles and the handle are all integrally moulded in one piece from a polymeric compound and in which a rigid strengthening member is embedded in the head and the handle.

30 The rigid strengthening member may be bent to impart a desired shape to the brush, e.g. for maintaining the handle at a desired angle to the head of the brush. The

strengthening member may comprise a steel, preferably a spring steel, rod. Alternatively, it may comprise a rod made of a suitable polymer or of a fibre such as glass fibre, asbestos, or the like.

The bristles may be circular in cross-section. Preferably, they are tapered in a direction away from the head. Alternatively, they may be substantially cylindrical in shape, optionally with their free edges chamfered.

- 10 The bristles may be arranged in rows. The bristles in one row may be staggered with respect to bristles in adjacent rows. The handbrush may comprise bristles of smaller diameter and bristles of larger diameter, all bristles having substantially the same length. The thinner bristles may be suitable for sweeping smaller dirt particles or dirt particles of smaller individual mass, and by virtue of being thinner, they may promote or facilitate the development of static electricity which in turn may cause the individual bristles to be
- 20 charged and to attract the or at least some of the dirt particles. The dirt particles may then subsequently be removed by rinsing the handbrush under running water.

The thicker bristles are preferably of greater rigidity than the thinner bristles and may be suitable for sweeping larger particles or particles of greater individual mass than the thinner bristles.

- To facilitate their cleaning action, the thicker bristles are preferably arranged in first rows whilst the thinner bristles are preferably arranged in second
- 30 rows. The second rows may alternate with the first rows, and the thicker bristles of one first row may be staggered with respect to the thicker bristles of

adjacent first rows. The thinner bristles of adjacent first rows are conveniently not staggered with respect to one another but are arranged opposite one another.

10 The head may be elongate in shape and the handle may extend from one end thereof. The head is conveniently provided with a scraper blade, which may also be integrally moulded with the head, the bristles and the handle. The scraper blade may extend longitudinally along one side of the head and may be of suitable thickness so as to facilitate cleaning of glass surfaces such as windows or the like.

The head may also be provided with a substantially longitudinally extending groove adapted to receive and to hold an edge of a steel blade suitable for removing ice from a motor vehicle's windscreen.

20 The handbrush may be made of a suitable polymeric material such as rubber and the composition of the rubber may be determined such that, upon vulcanisation, its hardness as may be expressed by the Shore hardness, is appropriate for use of the handbrush in cleaning (including brushing and washing) different parts of motor vehicles. A Shore hardness (as measured on the A scale) of between 55 and 65, preferably around 60 has been found to yield good results. Another important parameter of the handbrush is its elongation at break. As compared to other rubber products, the compound has to be formulated such as to have a rather high yield strength or elongation at break when vulcanised. I have found that an elongation at break of between about 550% and about 650% is required to yield good results in terms of mouldability and brushing performance. The preferred value for elongation at break is around 600%.
30 For washing purposes, the handbrush may be provided with

a cavity in its head, an inlet opening for introducing a washing or waxing aid into the cavity, closure means for closing the inlet opening, and passages interconnecting the cavity with the exterior of the head in the region of the bristles, so that a suitable liquid or solid washing or waxing aid such as a wetting agent, a soap, a detergent, a waxing liquid or the like may be placed in the cavity and applied to a vehicle or the like during washing thereof.

10 The invention will now be described, by way of example, with reference to the accompanying drawings, in which:

- Figure 1 is an underneath plan view of one handbrush according to the invention;
- Figure 2 is a sectional side view of the brush of Figure 1; and
- Figure 3 is a plan view of another handbrush in accordance with the invention.

In the drawings, reference numeral 10 generally indicates a handbrush comprising an elongate head 12 with a plurality of bristles 14 thereon and a handle 16 extending from one end of the head 12. The brush 10 comprising the head 12, the bristles 14 and the handle 16, is integrally moulded in one piece, from a rubber compound, formulated such as to provide to the brush the desired hardness, longevity, mouldability and rigidity of the bristles.

A strengthening member in the form of a spring steel rod 18, which is bent as shown at 18.1, is embedded in the brush 10. The rod 18 serves to impart rigidity to the 30 handle 16 and the head 12 and to maintain the handle 16

at a desired angle with respect to the head 12.

The handbrush 10 may be used for cleaning (including washing and brushing) upholstery, clothing, carpets, dishes, pets and horses.

The bristles 14 are of circular cross section and are tapered in a direction away from the head as is shown in Figure 2. The bristles 14 are arranged in rows as can be seen in Figure 1. The bristles in one row are staggered with respect to bristles in adjacent rows.

10 The handbrush 10 could, in other embodiments of the invention, comprise bristles 14 of smaller diameter and bristles 14 of larger diameter, all bristles 14 having substantially the same length. The head 12 is provided with a scraper blade 20 which is also integrally moulded together with the head 12, the bristles 14 and the handle 16. The scraper blade 20 extends longitudinally along one of the long sides of the head 12 and is of a suitable thickness so as to facilitate cleaning of glass surfaces such as windows or the like with its free edge 20.1. The free edge 20.1 is preferably substantially straight.

The head 12 is also provided with a substantially longitudinally extending groove on its long side opposite the side which is provided with the scraper blade 20. The longitudinally extending groove is adapted to receive and to hold an edge of a steel blade 22 as is shown in Figure 3, suitable for removing ice from a motor vehicle's windscreen.

30 The corners 20.2, 20.3 and 22.1, 22.2 of respectively the scraper blade 20 and the steel blade 22 are acute so as to facilitate entry into corners. The angles of the corners 20.2, 20.3 and 22.1, 22.2 are preferably all between 45° and 75°, more preferably around 60°.

The handbrush is made of a rubber compound, the composition of which is determined such that, upon vulcanisation, its hardness as may be expressed by the Shore hardness, is appropriate for use of the handbrush in cleaning (including brushing and washing) different parts of sensitive surface such as of motor vehicles, whilst still maintaining sufficient rigidity of the bristles 14 and scraper blade 20 to satisfactorily perform the functions of a brush. It is also of specific importance that care should be taken that the hardness of the handbrush is not so much as to be likely to damage the paint work of motor vehicles.

For washing purposes, the handbrush 10 is provided with a cavity 24 in the head 12, an inlet opening 26 for introducing a washing or waxing aid into the cavity 24, closure means (not shown) for closing the inlet opening, and passages interconnecting the cavity 24 with the exterior of the head in the region of the bristles 14, so that a suitable liquid or solid washing or waxing aid such as a wetting agent, a soap, a detergent, a waxing liquid or the like may be placed in the cavity and applied to a vehicle, animal or other object or article during washing thereof.

The claims which follow are to be considered an integral part of the disclosure.

THE CLAIMS DEFINING THE INVENTION ARE AS FOLLOWS:

~~XXXXXXXXXX~~

1. A method of manufacturing a handbrush comprising a head, a handle connected to the head and bristles projecting from the head, including the steps of
 - moulding the head, the handle and the bristles as one integral part from a polymeric compound; and
 - embedding in the head and the handle a rigid strengthening member.
2. A handbrush comprising a head, a handle connected to the head and a plurality of bristles projecting from the head, in which the head, the handle and the bristles are all integrally moulded in one piece from a polymeric compound and in which a rigid strengthening member is embedded in the head and the handle.
3. A handbrush as claimed in claim 2, in which the head is elongate in shape and the handle extends from one end of the head, the strengthening member comprising a spring steel rod bent such as to cause the handle to be disposed at an angle to the head.
4. A handbrush as claimed in claim 2, in which the bristles are circular in cross-section and tapered in a direction away from the head.
5. A handbrush as claimed in claim 2, in which some bristles are of smaller diameter and others are of larger diameter, all bristles being of substantially the same length.

6. A handbrush as claimed in claim 2, comprising a scraper blade for cleaning glass surfaces, the scraper blade being also moulded together with the head, bristles and handle as one integral piece.
7. A handbrush as claimed in claim 2, comprising a steel blade for removing ice from a motor vehicle's windscreen.
8. A handbrush as claimed in claim 6, made of a rubber compound formulated such as to impart to the handbrush upon vulcanisation thereof, a Shore hardness of between 55 and 65.
9. A handbrush as claimed in claim 2, in which the head is provided with a cavity having an inlet opening, closure means for closing the inlet opening and passages interconnecting the cavity with the exterior of the head in the region of the bristles, so that a suitable liquid or solid washing or waxing aid may be placed in the cavity and applied to an object during washing thereof.
10. A handbrush as claimed in claim 6, made of a rubber compound formulated such as to impart to the handbrush upon vulcanisation thereof, an elongation at break of between 550% and 660%

DATED this 15th day of February 1990.

CLIMPMINSTER LIMITED
CLIMPMINSTER LIMITED



WATERMARK PATENT & TRADEMARK ATTORNEYS
"THE ATRIUM"
290 BURWOOD ROAD
HAWTHORN. VIC. 3122.,

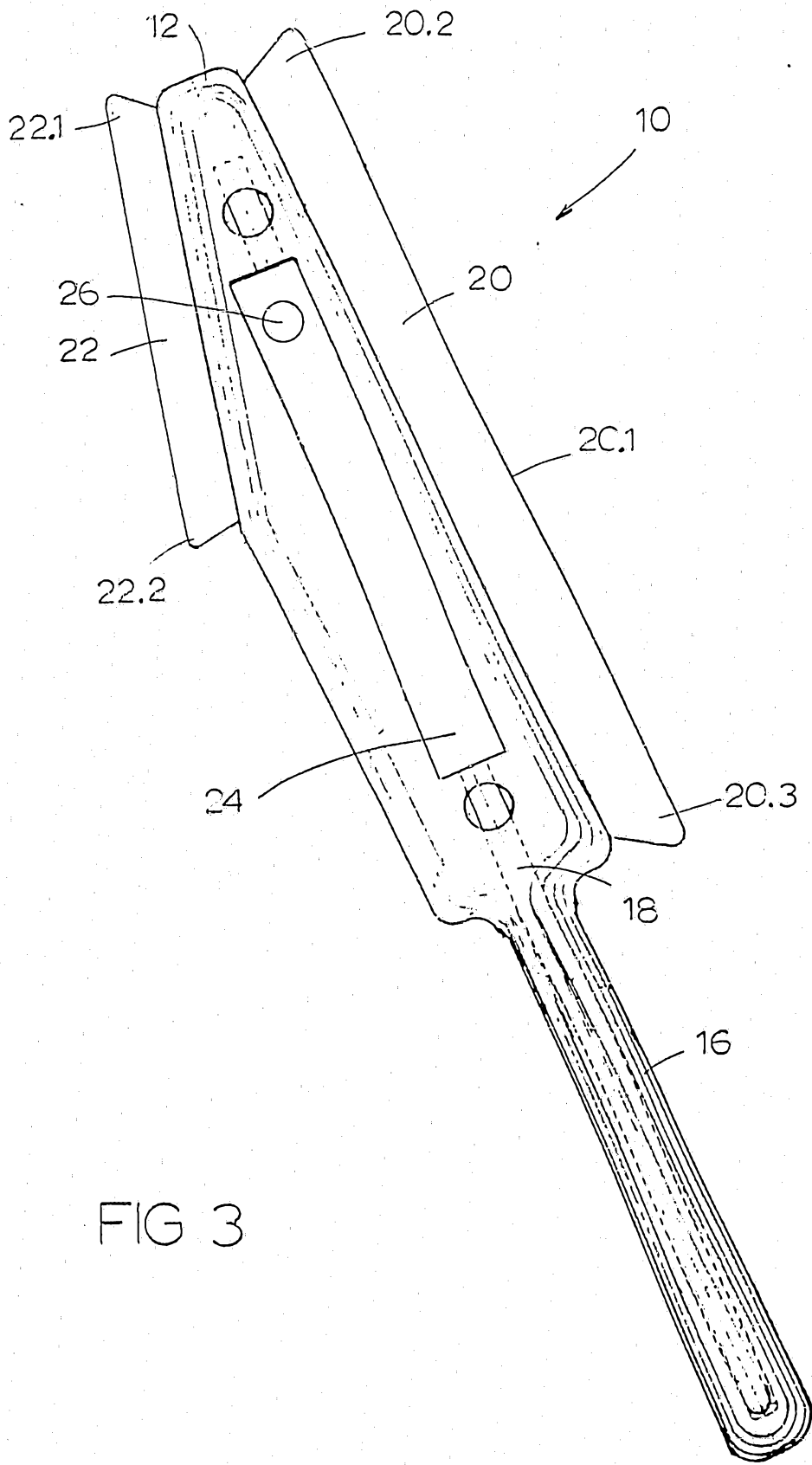

FIG 3