

(No Model.)

F. SPAHR.
FAUCET.

No. 568,217.

Patented Sept. 22, 1896.

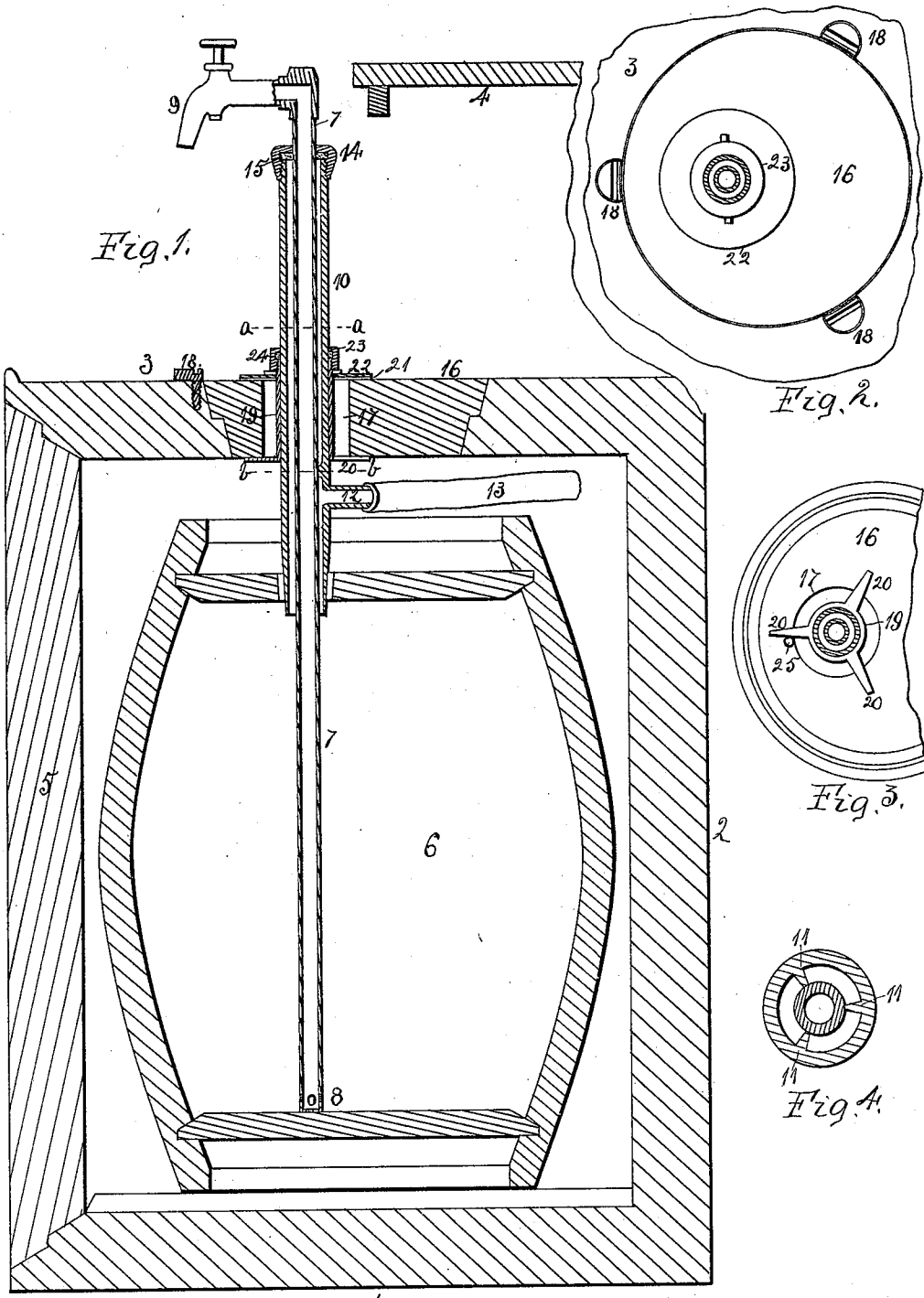

Witnesses:
E. M. Jackson.
E. Bedel

Inventor:
Fritz Spahr
By A. O. Bedel
attys

UNITED STATES PATENT OFFICE.

FRITZ SPAHR, OF ROCKFORD, ILLINOIS.

FAUCET.

SPECIFICATION forming part of Letters Patent No. 568,217, dated September 22, 1896.

Application filed September 10, 1895. Serial No. 562,089. (No model.)

To all whom it may concern:

Be it known that I, FRITZ SPAHR, a citizen of the United States, residing at Rockford, in the county of Winnebago and State of Illinois, have invented certain new and useful Improvements in Tapping Apparatus, of which the following is a specification.

The object of this invention is to construct a faucet for drawing beer, having a direct connection with the keg, and in which a casing is provided for the faucet, leaving an air-space between them in order that cold air may be forced in the space, acting to cool the faucet and beer contained therein.

In the accompanying drawings, Figure 1 is a transverse vertical section of a portion of a bar, showing the beer-keg located beneath the drain-board and a faucet connection with the keg. Fig. 2 is a section taken on dotted line *a*, Fig. 1, looking down. Fig. 3 is an under face representation of the removable cover, showing the pipes in transverse section. Fig. 4 is a transverse section of the pipes, taken on dotted line *b*, Fig. 1.

In the drawings I have shown a transverse section of a portion of a bar to which my improvements have been applied, consisting of the base 1, front 2, drain-board 3, and counter 4. The rear face is closed by a door 5. Within the space inclosed by the base, front, door, and drain-board I locate a beer-keg 6, and my improvements consist in applying a faucet direct to the keg through the drain-board.

The faucet consists of a vertical tube 7, having inlet-openings 8 at its lower end, and to its upper end is connected the faucet proper, 9, a casing 10, surrounding the vertical tube of the faucet, having its lower end tapering on the outside and its upper end screw-threaded. The inner face of the casing has three projections 11. (Shown at Fig. 4.) A branch 12 extends from the casing, to which is connected a tubing 13. The upper end of the casing is provided with a screw-threaded cap 14, having a packing-ring 15.

The drain-board 3 has a circular opening fitted with a circular cover 16, having a vertical opening 17, and clamps 18, supported by the drain-board, may be turned over the edge of the cover, holding it in position in connection with the drain-board.

A tubular section 19 surrounds the casing,

having a spider 20 connected to its lower end and having its upper end screw-threaded. This tubular section is located in the vertical opening in the cover, the arms of the spider lying against the under face of the cover. A packing-ring 21 is placed over the opening in the cover around the upper end of the section. A washer 22 is placed over the packing-ring, and a screw-threaded cap 23 has a connection with the upper end of the section and supports a packing-ring 24.

The keg is placed in position beneath the drain-board, so that the opening in the head will coincide with the vertical opening in the cover. The tubular section is located within the vertical opening of the cover and held in place by the screw-threaded cap.

The cover is placed over the tubular casing, a connection between the extension 12 of the casing and the tubing is made, the tubular portion 7 of the faucet is placed within the outer casing and driven into the opening in the head of the keg, the tapered lower end of the outer casing is forced within the opening in the keg, forming an air-tight joint, and after the vertical tubular portion of the faucet is seated upon the bottom of the keg the cap 14 is tightened, which will crowd the packing-ring against the outer face of the faucet tubular extension, making an air-tight joint.

By means of the cap 23 the spider is clamped against the under face of the cover and the packing 21 against the upper face of the cover, also the packing-ring around the tubular casing, which will hold the tubular casing in connection with the cover. One arm of the spider coming in contact with the stud 25 prevents its rotation. The opening in the cover is large enough to allow a movement to the outer casing to bring the faucet in line with the opening in the head of the keg and the opening in the cover eccentric thereto. The cover may be turned, if necessary, adjusting the faucet to the keg. The tubing 13 is intended to have a connection with an air supply under pressure.

The air will enter the keg around the vertical tubing and exert a pressure upon the upper surface of the beer sufficient to force the beer up through the tubing and out of the upper end of the faucet. The air will fill

the space between the pipes 7 and 10 and keep the inner pipe cool.

The keg of beer is placed in position in the cold condition it is received from the cold storage, the chamber in which it is placed kept at the required temperature by ice or circulation of cold air, and by drawing direct from the keg instead of through a coil of pipe less surface is exposed to accumulate objectionable matter and is easier kept clean.

I claim as my invention—

The combination of a drain-board of a bar, a circular opening therein, a cover for the opening consisting of a tubular bushing hav-

ing its upper end screw-threaded, the lower end of the bushing provided with radial arms, a stop with which one of the arms engages, a circular plate located over the opening in the drain-board a screw-threaded cap engaging the screw-threaded upper end of the bushing and resting upon the circular plate and a faucet passing through the bushing and screw-threaded cap.

FRITZ SPAHR.

Witnesses:

H. L. WYNKOOP,
A. O. BEHEL.