

(19) World Intellectual Property Organization
International Bureau



(43) International Publication Date
26 July 2001 (26.07.2001)

PCT

(10) International Publication Number
WO 01/53733 A1

- (51) International Patent Classification⁷: **F16K 15/14** [DE/DE]; Schenefelder Landstrasse 187, 22589 Hamburg (DE).
// E03F 1/00, F16K 15/16
- (21) International Application Number: PCT/FI01/00042 (74) Agent: **AWEK INDUSTRIAL PATENTS LTD OY**; P.O. Box 230, (John Stenbergin ranta 2), FIN-00101 Helsinki (FI).
- (22) International Filing Date: 19 January 2001 (19.01.2001)
- (25) Filing Language: English (81) Designated States (*national*): AE, AG, AL, AM, AT, AT (utility model), AU, AZ, BA, BB, BG, BR, BY, BZ, CA, CH, CN, CR, CU, CZ, CZ (utility model), DE, DE (utility model), DK, DK (utility model), DM, DZ, EE, EE (utility model), ES, FI, FI (utility model), GB, GD, GE, GH, GM, HR, HU, ID, IL, IN, IS, JP, KE, KG, KP, KR, KZ, LC, LK, LR, LS, LT, LU, LV, MA, MD, MG, MK, MN, MW, MX, MZ, NO, NZ, PL, PT, RO, RU, SD, SE, SG, SI, SK, SK (utility model), SL, TJ, TM, TR, TT, TZ, UA, UG, US, UZ, VN, YU, ZA, ZW.
- (26) Publication Language: English (84) Designated States (*regional*): ARIPO patent (GH, GM, KE, LS, MW, MZ, SD, SL, SZ, TZ, UG, ZW), Eurasian patent (AM, AZ, BY, KG, KZ, MD, RU, TJ, TM), European patent (AT, BE, CH, CY, DE, DK, ES, FI, FR, GB, GR, IE,
- (30) Priority Data:
200 01 004.2 21 January 2000 (21.01.2000) DE
- (71) Applicant (*for all designated States except US*): **EVAC INTERNATIONAL OY** [FI/FI]; Purotie 1, FIN-00380 Helsinki (FI).
- (72) Inventor; and
(75) Inventor/Applicant (*for US only*): **BOTH, Detlev**

[Continued on next page]

(54) Title: CHECK VALVE FOR AN INDIRECTLY CONTROLLED SOLENOID VALVE

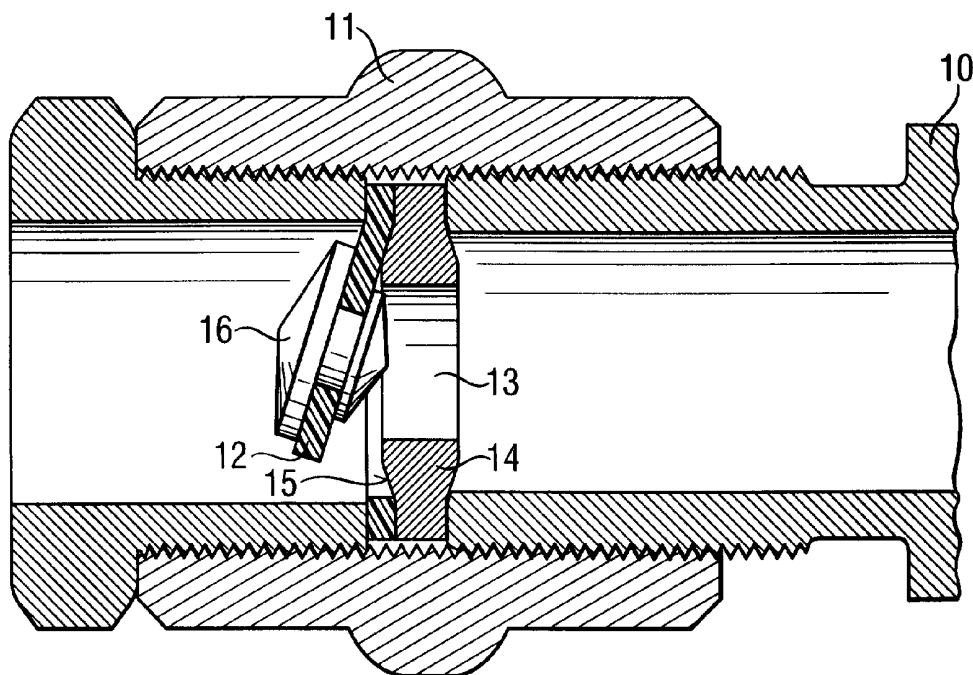

(57) Abstract: A check valve for an indirectly controlled solenoid valve for a vacuum toilet. In order to avoid malfunction during pressure changes, a double sleeve (11) is provided on a connection piece (10) of the solenoid valve, inside which a non-return flap (12) of flexible material is arranged, which forms a non-return assembly together with a counter plate (14) provided with a passage (13).



WO 01/53733 A1



IT, LU, MC, NL, PT, SE, TR), OAPI patent (BF, BJ, CF, CG, CI, CM, GA, GN, GW, ML, MR, NE, SN, TD, TG).

Published:

— *with international search report*

Declaration under Rule 4.17:

— *as to the applicant's entitlement to claim the priority of the earlier application (Rule 4.17(iii)) for all designations*

For two-letter codes and other abbreviations, refer to the "Guidance Notes on Codes and Abbreviations" appearing at the beginning of each regular issue of the PCT Gazette.

CHECK VALVE FOR AN INDIRECTLY CONTROLLED SOLENOID VALVE

The invention relates to a check valve for an indirectly controlled solenoid valve for a vacuum toilet according to the preamble of claim 1.

5 There are applications for valves, which are connected to the normal water supply, for example in a household, wherein the occurring pressure ensures that the valve closes itself, i.e. locks the device located behind it against the water pressure from the water supply. By means of an electro-
magnetic device the locking part of said valve may be opened so that water
10 can flow through it. When the pressure falls behind the valve, the valve will automatically return to the closed position. This is the usual requirement for example for a household washing machine. However, in applications, where a pressure can build up behind the valve - for whatever reasons - such a valve fails completely, since the pressure occurring behind the valve results
15 in that the valve does not return to its barrier position. Depending on the amount of pressure it is possible that water, for example, flows back and overcomes the pressure of the supply. There is a series of applications, where such a situation is highly undesirable, not in the least for sanitary reasons, for example when such valves are employed in sanitary systems, espe-
20 cially vacuum toilets.

A simple remedy for the indirectly controlled solenoid valves shall be provided by the present invention, which makes it possible to ensure in case of pressure surges that these pressure surges or a pressure build-up in general can not open the series valve under any circumstances. The inven-
25 tion thus provides for a check valve according to claim 1.

The solution according to the invention consists in that a so-called indirectly controlled solenoid valve, a kind of check valve, is provided behind the shut-off valve. In an ordinary operating situation with an opened shut-off valve, the non-return flap of the check valve assumes the opened position,
30 which can be achieved in the easiest way by placing a tongue-shaped part in

a kind of rubber ring out of the barrier position against the walls of the tubular housing of the valve, such that liquid can flow through.

However, if a pressure builds up from the other side of the check valve, this has the result that a valve part will be pushed onto a valve seat and seals and prevents thereby that the occurring pressure reaches the series
5 shut-off valve.

The check valve part consists mainly of a rubber ring, out of which a tongue-shaped part or a flap is formed by a punching process. The punching does not achieve a complete 360°, but leaves a bridge between the flap
10 and the surrounding ring part in a range of 30° to 60°, such that the root part of the flap serves as a hinge, to enable a transfer of the flap to a locking position at a valve seat or to an open position, respectively.

Further preferred embodiments of the invention are disclosed in claims 2 to 5.

15 The invention will now be explained more in detail in the following, by way of example, with reference to the to the accompanying schematic drawing, in which

Fig. 1 shows a longitudinal cross section through a check valve according to the invention, and

20 Fig. 2 shows a plane view of the non-return flap according to the invention.

In Fig. 1 and Fig. 2 the part of a connection piece of a solenoid valve (not shown) is indicated by reference numeral 10. This is a connection piece, which faces away from the approach flow side.

25 A double sleeve 11 is provided on, advantageously screwed onto the connection piece 10. A counter plate 14 having a passage 13 and abutting with the connection piece 10 is arranged inside the double sleeve 11. The counter plate consists of metal or a different somewhat flexible plastic material. Starting from the outside the counter plate 14 arches towards the
30 passage 13, such that a conical projection 15 is formed.

Abutting against the counter plate 14 is a non-return flap 12 of flexible material, advantageously of rubber or a flexible plastic. The non-

return flap 12 and the counter plate 14 are locked closely adjacent inside the double sleeve 11 through a screw coupling.

The non-return flap 12 may consist of a rubber disc, out of which a circular area, not extending over 360°, however, has been punched out. In
5 Fig. 2 this area of the non-return flap 12 is hatched for illustration purposes.

The non-return flap 12, e.g. in the form of a rubber disc, is formed with a passage inside it, in which in turn a supporting plate 16 is received. The supporting plate consists of two conical parts extending away from each other and a cylindrical part, wherein it is possible, to insert said supporting
10 plate 16 due to the elasticity of the non-return flap 12 into the passage of the non-return flap 12.

In the embodiment shown in Fig. 1, the conical projection 15 effects that the non-return flap 12 is not to be seen in the completely sealed position, although it is the pressureless state. This construction is preferred,
15 because a low-flow resistance can be obtained this way, namely when the non-return plate shall be transferred into the opened position.

If a pressure applies from the side of the counter plate 14 and if thus liquid strives to flow through the passage 13, the non-return flap 12 deforms so that the supporting plate 16 abuts at the top against the walls of
20 the screwing piece and the liquid can flow in unhindered.

If, in contrast, the solenoid valve is turned off and a pressure builds up on the other side of the non-return flap 12 for some reason, this could, if the non-return flap 12 would not exist, open the indirectly controlled solenoid valve, which is not desired, however. Due to the fact that the non-return flap
25 12 is arranged inside the double sleeve 11, however, the occurring pressure can bring the non-return flap 12 fixedly and tightly into the actual seat, such that the solenoid valve is not acted upon by this pressure.

CLAIMS

1. A check valve for an indirectly controlled solenoid valve for a vacuum toilet, **characterised in that** a double sleeve (11) is provided on a connection
5 piece (10) of the solenoid valve, inside which a non-return flap (12) of flexible material is arranged, which forms a non-return assembly together with a counter plate (14) provided with a passage (13).

2. A check valve according to claim 1, **characterised in that** the counter plate
10 (14) is provided at the surface facing the non-return flap (12) with a projection or a conical formation (15) deforming the non-return flap (12) in the pressureless state out of the closed position.

3. A check valve according to claim 1 or 2, **characterised in that** the non-
15 return flap (12) is provided with an apertured passage, in which a supporting plate (16) is inserted.

4. A check valve according to claim 1, **characterised in that** the non-return
flap (12) is in the form of a rubber disc.

20

5. A check valve according to claim 1, **characterised in that** the double
sleeve (11) is screwed onto the connection piece (10) of the solenoid valve.

1/1

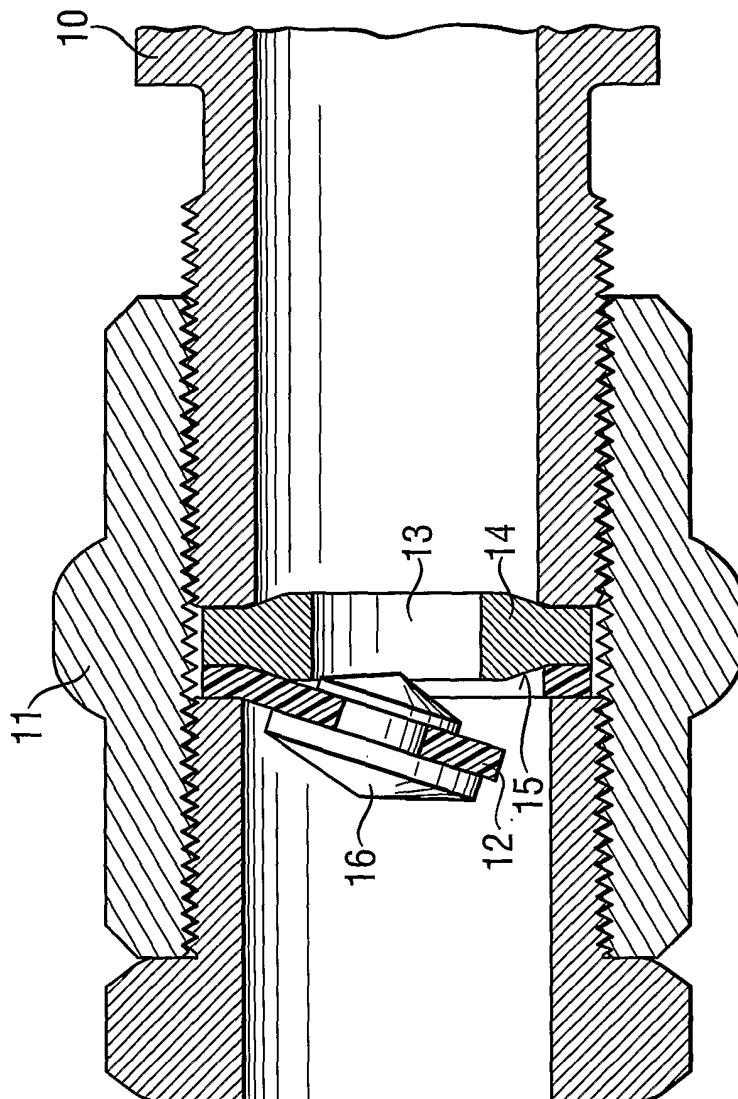

Fig. 1

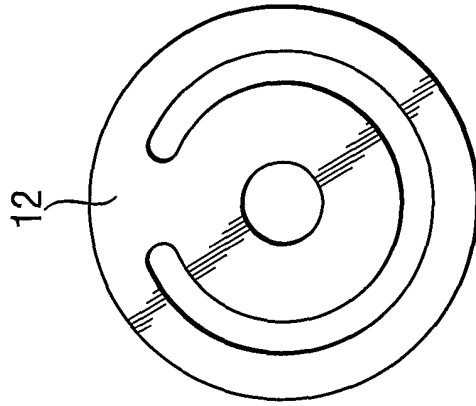

Fig. 2

INTERNATIONAL SEARCH REPORT

International application No.

PCT/FI 01/00042

A. CLASSIFICATION OF SUBJECT MATTER

IPC7: F16K 15/14 // E03F 1/00, F16K 15/16

According to International Patent Classification (IPC) or to both national classification and IPC

B. FIELDS SEARCHED

Minimum documentation searched (classification system followed by classification symbols)

IPC7: E03F, F16K

Documentation searched other than minimum documentation to the extent that such documents are included in the fields searched

SE,DK,FI,NO classes as above

Electronic data base consulted during the international search (name of data base and, where practicable, search terms used)

C. DOCUMENTS CONSIDERED TO BE RELEVANT

Category*	Citation of document, with indication, where appropriate, of the relevant passages	Relevant to claim No.
A	EP 0638328 A1 (B. BRAUN MELSUNGEN AG), 15 February 1995 (15.02.95) --	
A	GB 2266133 A (ATSUGI UNISIA CORPORATION), 20 October 1993 (20.10.93) --	
A	EP 0445462 A1 (BURTON MECHANICAL CONTRACTORS, INC.), 11 Sept 1991 (11.09.91), abstract, detail 80 --	
A	US 4275470 A (BADGER ET AL), 30 June 1981 (30.06.81), column 4, line 68, detail 31 -- -----	

 Further documents are listed in the continuation of Box C.
 See patent family annex.

* Special categories of cited documents:

"A" document defining the general state of the art which is not considered to be of particular relevance

"E" earlier application or patent but published on or after the international filing date

"L" document which may throw doubts on priority claim(s) or which is cited to establish the publication date of another citation or other special reason (as specified)

"O" document referring to an oral disclosure, use, exhibition or other means

"P" document published prior to the international filing date but later than the priority date claimed

"T" later document published after the international filing date or priority date and not in conflict with the application but cited to understand the principle or theory underlying the invention

"X" document of particular relevance: the claimed invention cannot be considered novel or cannot be considered to involve an inventive step when the document is taken alone

"Y" document of particular relevance: the claimed invention cannot be considered to involve an inventive step when the document is combined with one or more other such documents, such combination being obvious to a person skilled in the art

"&" document member of the same patent family

Date of the actual completion of the international search

26 April 2001

Date of mailing of the international search report

30 -04- 2001

 Name and mailing address of the ISA/
 Swedish Patent Office
 Box 5055, S-102 42 STOCKHOLM
 Facsimile No. +46 8 666 02 86

Authorized officer

 Sune Söderling / JA A
 Telephone No. +46 8 782 25 00

INTERNATIONAL SEARCH REPORT

Information on patent family members

International application No.

02/04/01

PCT/FI 01/00042

Patent document cited in search report	Publication date	Patent family member(s)	Publication date
EP 0638328 A1	15/02/95	DE 9310673 U	18/08/94
GB 2266133 A	20/10/93	DE 4036613 A,C	23/05/91
		DE 4042638 C	24/07/97
		GB 2238843 A,B	12/06/91
		GB 9024880 D	00/00/00
		JP 2918257 B	12/07/99
		JP 3157532 A	05/07/91
		US 5129488 A	14/07/92
		US 5261448 A	16/11/93
		JP 2918258 B	12/07/99
		JP 3181633 A	07/08/91
		JP 2742457 B	22/04/98
		JP 3181680 A	07/08/91
EP 0445462 A1	11/09/91	AU 631249 B	19/11/92
		AU 6316690 A	12/09/91
		CA 2028587 A	10/09/91
		JP 2879992 B	05/04/99
		JP 5118080 A	14/05/93
		US 5044836 A	03/09/91
		US 5064314 A	12/11/91
US 4275470 A	30/06/81	DE 3026763 A	12/02/81
		DE 8018966 U	27/05/81
		FR 2461646 A,B	06/02/81
		GB 2054688 A,B	18/02/81
		GB 2121079 A,B	14/12/83
		JP 1878039 C	07/10/94
		JP 5085698 B	08/12/93
		JP 56085039 A	10/07/81
		US 4357719 A	09/11/82
		US 4376315 A	15/03/83