

(No Model.)

4 Sheets—Sheet 1.

N. LOMBARD. LASTING MACHINE.

No. 524,444.

Patented Aug. 14, 1894.

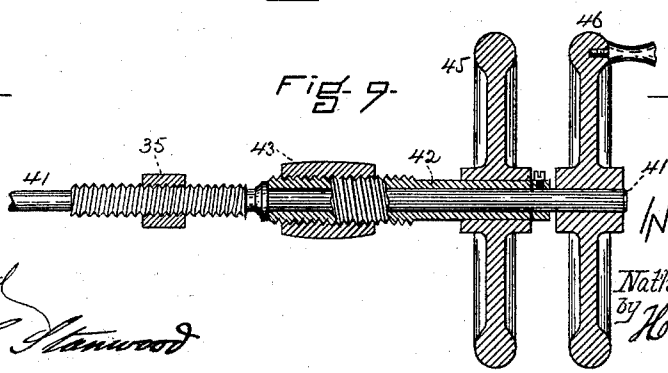
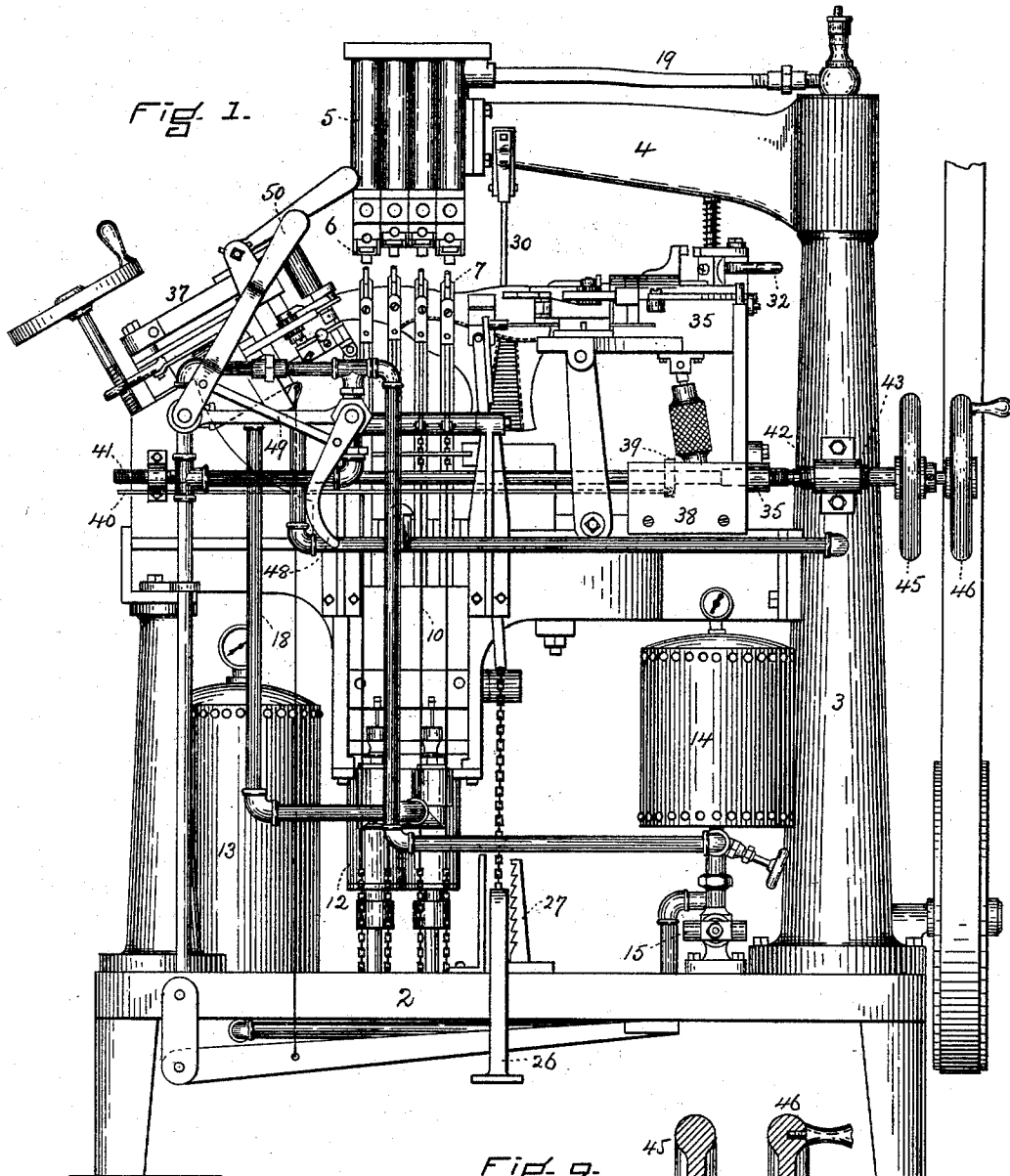

WITNESSES.

Geo F Wood
Francis C. Stanwood

INVENTOR.

Nath. Lombard.
By H. S. Lodge, Att.

(No Model.)

4 Sheets—Sheet 2.

N. LOMBARD.
LASTING MACHINE.

No. 524,444.

Patented Aug. 14, 1894.

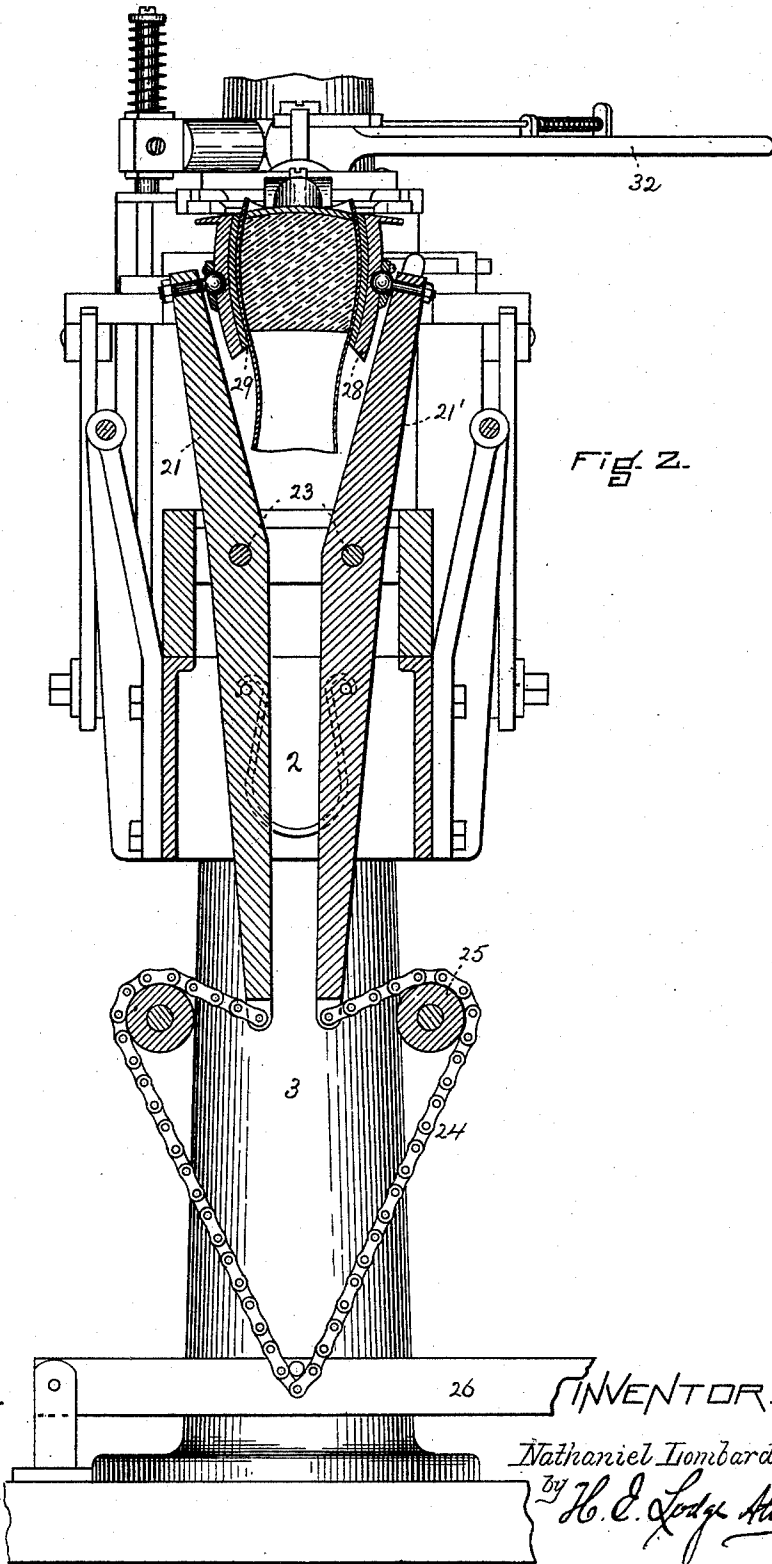

FIG. 2.

WITNESSES.

Geo F. Wood
J. C. Stanwood

INVENTOR.

Nathaniel Lombard.
By H. E. Lodge Atty.

(No Model.)

4 Sheets—Sheet 3.

N. LOMBARD. LASTING MACHINE.

No. 524,444.

Patented Aug. 14, 1894.

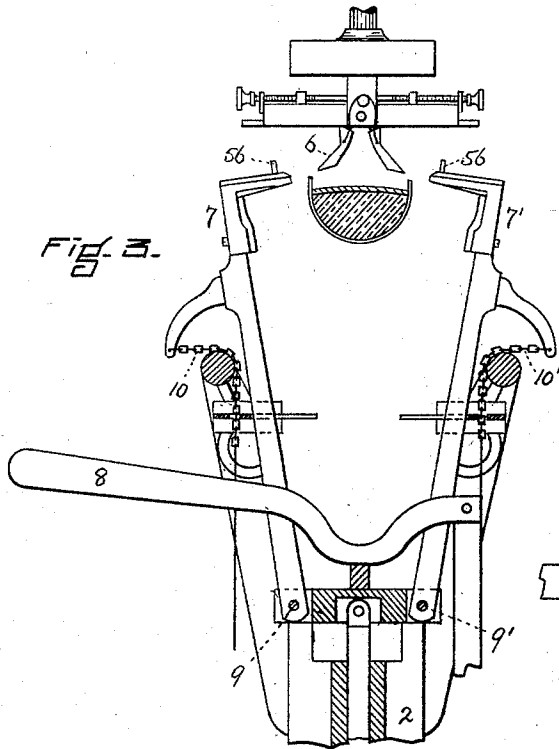

Fig. 3.

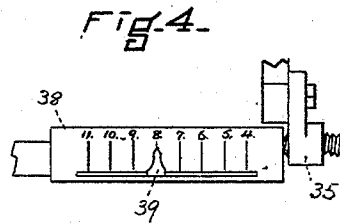

Fig. 4.

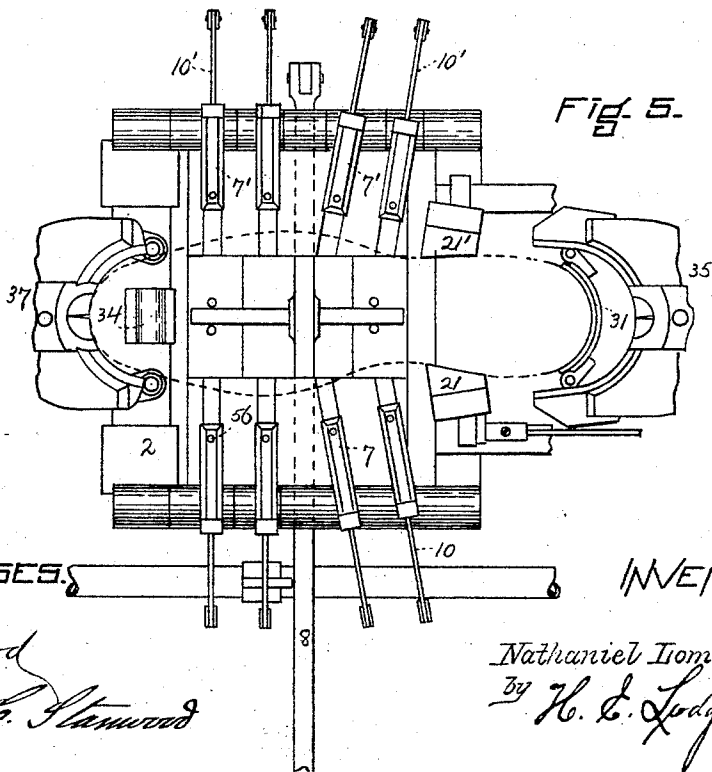

Fig. 5.

WITNESSES:

Geo. F. Wood
Francis C. Stanwood

INVENTOR:

Nathaniel Lombard.
By H. E. Lodge Atty.

(No Model.)

4 Sheets—Sheet 4.

N. LOMBARD. LASTING MACHINE.

No. 524,444.

Patented Aug. 14, 1894.

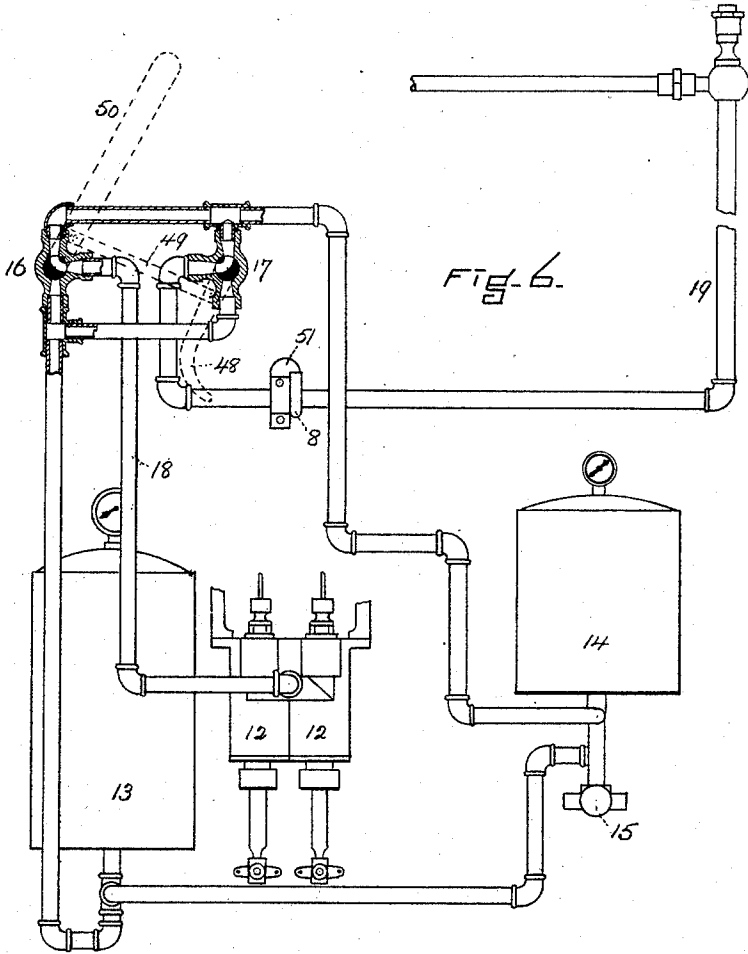

Fig. 6.

Fig. 7.

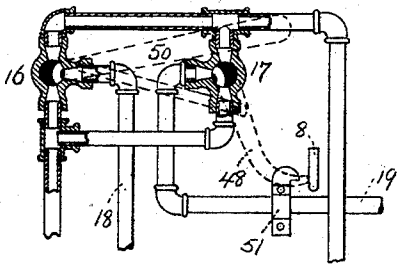
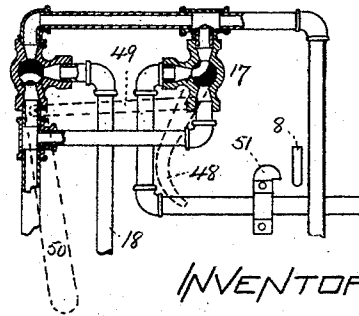

Fig. 8.



WITNESSES.

Geo. F. Wood
Francis C. Starnord

INVENTOR-

Nathaniel Lombard.
by H. E. Lodge Atty.

UNITED STATES PATENT OFFICE.

NATHANIEL LOMBARD, OF BOSTON, MASSACHUSETTS, ASSIGNOR TO THE
AUTOMATIC LASTING MACHINE AND MANUFACTURING COMPANY, OF
PORTLAND, MAINE.

LASTING-MACHINE.

SPECIFICATION forming part of Letters Patent No. 524,444, dated August 14, 1894.

Application filed November 4, 1893. Serial No. 489,993. (No model.)

To all whom it may concern:

Be it known that I, NATHANIEL LOMBARD, a citizen of the United States, residing at Boston, in the county of Suffolk and State of Massachusetts, have invented certain new and useful Improvements in Lasting-Machines; and I do hereby declare the following to be a full, clear, and exact description of the invention, such as will enable others skilled in the art to which it appertains to make and use the same, reference being had to the accompanying drawings, and to figures of reference marked thereon, which form a part of this specification.

This invention relates to power-lasting machines and its purpose and object is to render the act of lasting automatic, particularly that portion of the upper termed the quarter.

This invention relates to and may be considered as an improvement upon the machine shown and described in application, Serial No. 452,659, filed in my name on November 21, 1891.

The prominent features in my present invention consist first, in the omission of the jack thereby obviating the objections incidental to its use. Secondly, in providing mechanism by which the two carriages upon which are mounted the heel and toe-lasting appurtenances are made to have simultaneously movement either in opposite directions, or both in the same direction. Thirdly, in providing a scale and pointer to enable the distance, which the carriages are apart to be expressed by numerals such as are usually adopted by boot and shoe manufacturers to distinguish different sizes. Fourthly, in providing apparatus for supplying power and in the arrangement of a single lever by which the act of lasting the shoe (with the exception of the heel and toe portions) is rendered entirely automatic.

Briefly described, my improved power-lasting machine consists in two movable carriages on which are mounted heel and toe-lasting appurtenances of any approved construction. In addition are two groups of lasting fingers (upper and lower) operated by pressure and vacuum service, and controlled by a single lever in connection with apparatus for supply-

ing power to actuate them. Furthermore the jack is omitted and the last with the upper is held in position for being lasted by a pair of last-holding levers, while a flexible clamping band supports the heel, and an adjustable rest is provided for the toe. The heel and toe-lasting appurtenances are positioned according to the size of shoe by actuating the proper mechanism until the pointer indicates on the scale the desired size by a numeral, 7, 6 or 10, as the case may be.

Other peculiarities of my invention showing the various co-operating elements and their relations to each other as well as a description of the complete act of lasting will be hereinafter fully explained.

The drawings accompanying this specification represent in Figure 1 a side elevation of a power-lasting machine embodying my invention. Fig. 2 is a vertical transverse section looking toward the heel. Fig. 3 is a transverse view in part showing the upper and lower groups of lasting fingers in elevation. Fig. 4 is a plan of the scale for indicating in sizes the distance of the heel and toe-lasting instrumentalities apart. Fig. 5 is a plan view. Fig. 6 is a diagram of the power supplying apparatus, showing in section the valves and their operating lever in one position during the act of lasting. Fig. 7 is a sectional view in part of the same showing a further change in said valves due to movement of the lever as the act of lasting proceeds. Fig. 8 is a similar view after the act of lasting is completed. Fig. 9 is a longitudinal section of the mechanism for controlling the movement of the heel and toe-lasting carriages.

In the above drawings I have shown a power-lasting machine as follows: A suitable frame or standard 2, 2. is provided to support the various operating parts, while a vertical post 3 is surmounted with a swinging arm 4 having a series of cylinders 5 to which are attached a group of pendent lasting fingers 6, designated as the upper group. Below and suitably mounted are positioned a second group of upright lasting fingers 7 similarly operated. The individual members composing this lower group are united together, so as to be capable of adjustment in vertical

planes by means of a lever bar 8. Hence they can be drawn down to the level of the bottom of the last when it is so desired. Said lower lasting fingers are furthermore pivoted at 9 9' and are adapted to rock or advance toward the last at proper times by means of flexible bands 10 connecting with the pistons of a second group of cylinders 12.

The apparatus for supplying power by reference to Fig. 6 consists in two receptacles, one for pressure 13, one for vacuum service 14. The vacuum being created by filling the reservoir 14 preferably with oil and by means of a pump 15 actuated from some prime motor filling the vessel 13. Pipes with two primary valves 16, 17 both operated by a single lever 50 connect said vessels 13, 14 with the two sets of cylinders: the pipe 18 extending to the lower set of cylinders 12 while the pipe 19 acts similarly for the upper cylinders 5. Thus as the oil under pressure after use in the cylinders is returned to the vessel 14 the pump again forces it into the pressure tank 13 to maintain pressure in one vessel and a vacuum in the other. The pump is intended to be in constant operation but it is evident that power is expended only when liquid is to be removed from the vacuum tank.

One of the serious objections in the act of lasting is the use of a jack, so called, while the wear of the last and other disadvantages, well known to those skilled in the art, are concomitant with its employment. Hence as before premised one of the prominent features is to do away with this element. To carry out my purpose and to hold the last as firmly and securely as if a jack were present, I arrange two last clamping levers 21, 21' laterally of the last and adjacent to the quarter. Reference to Fig. 2 shows these levers pivoted to the frame 2 at 23 with a spring to thrust them apart. Their lower extremities are united to a flexible band or bands 24, which pass over anti-friction rolls 25, said band or chain being secured to a foot bar 26, the latter engaging a toothed post 27 for variable adjustment. The upper ends of these levers 21 are furnished with jaws 28 somewhat curved to conform to the shape of the last and mounted for universal movement. The inner surface of these jaws is faced with soft material 29 to prevent injury to the leather.

In connection with my improvements and non use of the jack, I provide a gage 30 upon the swinging arm 4 and pendent therefrom: this gage is fixed and always maintains the same relative position for all sizes of shoes. Thus having the heel and toe carriage properly positioned the last is introduced between the lower group of fingers 7 and then raised until the insole contacts against the gage. The foot bar 26 is now depressed and locked in the post 27, while the jaws are forcibly pressed against the last with the upper holding them firmly in position. Prior to the act of lasting the flexible clamping band 31 on

the heel-lasting carriage is thrust against the heel portion of the upper by aid of the lever 32, see Fig. 2, while the toe rest 34 is brought into proper position by suitable mechanism. Thus the last is supported at three points, which now remain fixed and immovable until the complete act of lasting is effected.

A further important feature in this machine is embodied in the appliances by which the distance apart of the heel and toe-lasting appurtenances is indicated graphically by a graduated scale with a pointer. Hence, if the operator is to last a No. 6 shoe he moves the pointer to the desired numeral, and is then assured that the proper distance between the heel and toe carriages has been obtained before he introduces the last. This effects a great saving of time. Reference to Fig. 1 shows the heel carriage at 35 and the toe carriage at 37, both of which may be fitted with lasting appliances of any approved construction. The description of the specific elements and their relations to each other are intentionally omitted as they have nothing in common with my present invention. With the above premise I will say that a graduated scale 38, see Fig. 4, is attached to the heel carriage, while the toe carriage actuates the pointer 39 connected thereto by a rod 40, see Fig. 1. Moreover a screw-threaded shaft 41, see Figs. 1 and 9, is fitted with right and left screw threads respectively to engage each carriage, while a sleeve shaft 42 engages a tubular bracket 43 secured to the post 3. This bracket is interiorly threaded and receives a threaded portion of the sleeve shaft 42; this latter is controlled by the hand wheel 45, a similar wheel 46 is affixed to the shaft 41. In this way simultaneous opposite movement of the carriages, either toward or from each other, can be produced and such acts are accomplished by rotation of the shaft 41. But should it be desired to shift the two carriages without altering their position relatively with respect to each other then the sleeve shaft only is to be revolved.

A further prominent characteristic in my invention is embodied in the single lever 50, a latch 48 and a connecting rod 49. The lever 50 is secured to the valve rod of a three way valve 16 before mentioned, while the latch 48 is attached to the valve rod of the three way valve 17, the function of the latch being to release the lever bar 8 after the upper group of lasting fingers have taken their positions upon the surface of the insole. Thus by my invention the operator is required merely to swing the lever 50, and the act of lasting is instantly accomplished with the exception of the heel and toe portions.

The act of lasting under my improved power machine is as follows, it being understood that liquid under pressure exists in the vessel 13, with a vacuum in 14, while the swinging arm and upper lasting fingers are swung to one side. Further both valves 16, 17 are closed to the pressure vessel and open to the

vacuum. The first step is to depress the lever bar 8 and lock it with the catch 51, see Fig. 6; this draws down the lower group of lasting fingers, which are wide open. The shoe is now placed between said fingers and the arm 4 is then swung over in alignment above the last and the latter raised until the insole meets the gage 30. The foot bar 26 is now actuated and the last holding levers drawn together to firmly grip the last, said foot bar being locked by means of the toothed post 27. The flexible clamping band now secures the heel by aid of the lever 32 while the toe support 34 is properly positioned beneath the toe. The upper is now in readiness for lasting and the operator proceeds to swing the lever 50 toward the right, see Fig. 7, until valve 17 is opened to admit liquid under pressure to the cylinders 5 when the upper lasting fingers 6 are thrust down upon the insole but adjacent to the edges of the upper. At this time the valve 16 has now rotated to shut off the vacuum vessel from the lower cylinders, and the latch 48 has been rocked and thrust against the lever bar 8 to release the latter and allow the lower group of lasting fingers to rise up, the pins 56 entering the lateral under portions of the upper groups. A slight further motion of the lever 50 now opens the valve 16 which admits liquid under pressure to the lower cylinders and the lasting fingers 7 are thrust forcibly inward, the upper being held between the two groups of fingers and drawn snugly about the last. A further advance swing of this lever 50, see Fig. 8, again changes the positions of the valves 16, 17 to close the former and cut off communication of both vessels 13, 14 from the lower cylinders leaving their pistons under the action of the liquid pressure and so holds said lower group 7 tightly upon the last; moreover the latter valve 17 has been shifted to cut off pressure from the vessel 13 and now connects the pipe 19 with the vacuum vessel 14. When this occurs the pressure ceases, the liquid being drawn back into said vessel 14 while the upper group of lasting fingers is released and the arm 4 swung off to one side to its first original position. Since the lower group of fingers is now under pressure the leather upper is held firmly upon the last until properly tacked. The toe and heel portions are now finished by means of the proper lasting appurtenances and when said acts are fully completed a final reversal of the lever 50 occurs and it resumes its first position, see Fig. 6, where it will be seen that the pipe 18 is now connected with the vacuum chamber 14, hence the pressure in the lower cylinders is nothing, and the lower group of lasting fingers is again drawn back wide open, when the shoe may be removed after the heel and toe portions have been freed from the mech-

anism for operating upon such portions of the upper.

It is to be understood that the operation of the lever 50 is somewhat slow, while these several and varying conditions occur, to wit: of rendering the upper group of fingers active, followed by activity of the lower group, cooperation of the two groups, inactivity of the upper group, continued activity of the lower group, and final inactivity of the lower group, all which in fact is one continuous action and occupies only a few seconds. In furnishing a single lever, the operator is relieved of all care and attention for the several successive steps, and the act of lasting is made as nearly automatic as is possible. Thus the swing of the lever 50 insures uniformity of action and every shoe is treated in precisely the same manner.

It will be understood that in lasting heavy or light uppers the pressure would be varied, but usually the pressure is the same for similar classes of goods.

What I claim is—

1. In a power lasting machine, the combination with heel and toe lasting appurtenances, of two groups of lasting fingers (upper and lower), mechanism for operating both groups simultaneously to grip the upper, and a pair of last-holding levers applied exteriorly of the upper along the quarter and adapted to afford a center support in lieu of a jack, substantially as and for purposes set forth.

2. In a power lasting machine, the combination with two vessels for pressure and vacuum service, a pipe system therebetween, two groups of lasting fingers (upper and lower) with means for actuating the same, of two valves each to control pipes to the pressure and vacuum vessels, a single lever for operating both valves, and a latch controlled by said lever to permit upward movement of the lower group of lasting fingers, and means to connect said latch with the lever, substantially as stated.

3. In a power lasting machine, a group of upper lasting fingers, a group of lower lasting fingers, and a lever bar 8 for depressing the lower group simultaneously, combined with a latch, two valves which control pipes for pressure and vacuum service, an operating lever and a rod which unites said latch and lever whereby the lever serves to open and close the said valves and release the latch at predetermined intervals of time during the act of lasting, substantially as explained.

In testimony whereof I affix my signature in presence of two witnesses.

NATHANIEL LOMBARD.

Witnesses:

H. E. LODGE,
FRANCIS C. STANWOOD.