

DISC SHAPED FILTER

Background of the Invention

1. Field of the Invention

The present invention pertains to filtering devices. More particularly, the present invention pertains to devices and methods for filtering embolic debris from a blood vessel.

2. Description of the Related Art

Occluded, stenotic, or narrowed blood vessels may be treated with a number of relatively non-invasive medical procedures. For example, occlusions of blood vessels near the heart may be treated by percutaneous transluminal angioplasty (PTA), percutaneous transluminal coronary angioplasty (PTCA), atherectomy, etc. Similarly, a number of occlusions may occur in other blood vessels located a distance away from the heart. For example, an occlusion may occur within the renal artery between the abdominal aorta and the kidney. Because this vascular region is relatively short in length, an appropriate intervention may necessitate design modifications of current intravascular devices.

When treating occluded or stenotic blood vessels, embolic debris can be separated from the wall of the blood vessel. This debris could block other vascular regions including the renal, neural, and pulmonary vasculature or cause damage to tissue and/or body organs. In order to filter this debris, a number of devices, termed distal protection devices, have been developed.

Brief Summary of the Invention

The present invention pertains to distal protection filter devices. A distal protection filter may be coupled to an elongate shaft. The filter may be generally cylindrical or disc shaped and has a diameter and a length. The length is relatively small and may be smaller than the diameter. The filter may be used to capture embolic debris generated by an intravascular intervention. Aspiration means may be included to aspirate the embolic debris from the filter.

The filter may shift between a generally collapsed configuration and a generally expanded configuration by a number of methods. For example, an outer sheath may be disposed over the shaft and filter such that movement of the sheath relative to the shaft shifts the configuration of the filter. Alternatively, an expansion member may be actuated to shift the filter.

Brief Description of the Several Views of the Drawings

Figure 1 is a cross sectional view of a distal protection filter;

Figure 2 is a partial cross sectional view of depicting an alternate means for shifting the filter between the expanded and the collapsed configuration; and

Figure 3 is a partial cross sectional view of the filter in Figure 2 in the expanded configuration.

Detailed Description of the Invention

The following description should be read with reference to the drawings wherein like reference numerals indicate like elements throughout the several views. The detailed description and drawings illustrate example embodiments of the claimed invention.

A number of diagnostic and therapeutic interventions may result in the release of intravascular embolic debris. Several filtering devices have been developed to capture and/or remove this debris. However, some procedures and intravascular locations are not readily accessible to traditional filters. Figure 1 is a cross sectional plan overview of a disc-shaped distal protection filter device 10. Filter device 10 includes a filter 11 attached to an elongate shaft 12. The design of filter device 10 permits filtering at intravascular locations that might otherwise not be readily accessible by traditional filters.

Shaft 12 may comprise a guidewire or intravascular catheter, similar to any number of those known in the art or as detailed below. A distal spring tip 16 may be disposed at a distal end 18 of shaft 12. Sheath 14 may be generally polymeric and is adapted and configured to be advanced through the vasculature to an area of interest. Once positioned, sheath 14 may be withdrawn proximally to deliver filter 11.

Filter 11 includes a filter material 20 coupled to a filter frame 22. Filter material 20 may be comprised of a polyurethane sheet and include at least one opening that may be, for example, formed by known laser techniques. The holes or

openings are sized to allow blood flow therethrough but restrict flow of debris or emboli floating in the body lumen or cavity.

Filter 11 operates between a closed collapsed profile and an open radially-expanded deployed profile for collecting debris in a body lumen. Frame 22 may be self-expanding or otherwise biased to be oriented in the expanded configuration so that withdrawing sheath 14 allows filter 11 to shift to the expanded configuration. A number of methods may be used to shift filter 11 from the expanded configuration to the collapsed configuration. For example, filter 11 may include a plurality of longitudinally-extending struts 24 that extend between frame 20 to shaft 12. It can be appreciated that a number of methods for shifting filter 11 between the collapsed and expanded configuration can be used without departing from the spirit of the invention.

Filter 11 is designed to be disc shaped and/or cylindrical. The cylindrical shape of filter 11 can be understood to have a diameter D and a length L. Diameter D may generally be larger than length L such that filter 11 has a shape that differs from typical conically shaped filters. This characteristic of having a relatively short or thin length may be described as having a "short landing zone" to those in the art. Having a short landing zone can advantageously permit filter 11 to be used at intravascular locations that are relatively short and would otherwise be inaccessible to traditional filters. For example, the length of a portion of the renal artery between the abdominal aorta and the kidney is relatively short. Diagnosis or other interventions at the junction of the renal artery and the kidney would not easily be accomplished by using a conically shaped filter because the filter may extend into the kidney, possibly causing damage to the kidney. Because of the shape of filter 11, this location is accessible for filtering by filter 11. A number of additional intravascular locations may similarly benefit from the shape of filter 11.

The dimensions of filter 11 may include diameter D being about 0.10 to 0.30 inches or less and length L may be about 0.01 to 0.15 inches or less. These dimensions are meant to be approximations and provided for illustration purposes. The dimensions may be altered for any one of multiple embodiments.

Shaft 12 may be generally tubular so as to define an aspiration lumen 26 extending therethrough. Aspiration may be important because the thin length of filter 11 may cause filter material 20 to become filled to its capacity with embolic material.

Aspiration lumen 26 is connected proximally to a vacuum source and is used to aspirate embolic debris collected on filter material 20.

In use, filter 11 may be contained within sheath 14 and advanced within a blood vessel 28 to an area proximate a lesion 30. Blood vessel 28 may, for example, be the renal artery between the abdominal aorta and the kidney. Once positioned, sheath 14 may be withdrawn from filter 11, permitting filter 11 to shift to the expanded configuration. A therapeutic or diagnostic catheter may be advanced to lesion 30 (i.e., over shaft 12 or sheath 14). Embolic debris released by the intervention is captured by filter material 20. Aspiration lumen 26 may be used to aspirate the debris from filter material 20.

Figure 2 is a partial cross section of an alternate filter device 110 that is the same in form and function as device 10 except that filter device 110 includes alternative means for shifting filter 111 between the expanded and the collapsed configuration. Filter 111 may be expanded by actuating a coiled expansion member 132.

Expansion member 132 may include a generally straight proximal portion 134 extending to the proximal end of shaft 12, and a coiled distal portion 136. Distal portion 136 is coupled to filter 111 such that force applied to proximal portion 136 in the distal direction exerts force onto filter 111 in the distal direction and shifts filter 111 distally. Distally shifting filter 111 results in filter 111 shifting to the expanded configuration.

Proximal portion 134 may be connected to a manifold, actuating handle, etc. that permits expansion member 132 to be moved relative to shaft 12 by a clinician. According to this embodiment, expansion member 132 is slidably disposed within shaft 12 and may be moved in either a proximal or distal direction. This may permit the use of filter 111 without the need for a separate delivery or retrieval catheter, which may simplify use and/or overall profile of the device. Moreover, bi-directional motion of expansion member 132 may allow filter 111 to be positioned in one location, expanded by distal motion of expansion member 132, filter embolic debris, collapsed by proximal motion of expansion member 132, and moved to another location for use.

To expand filter 111, distal portion 136 is generally tightly coiled within shaft 12 such that when it is allowed to advance distally out of shaft 12, distal portion 136 expands to expand filter 111 as shown in Figure 3. It may be beneficial to construct expansion member 132 (or at least distal portion 136) of a shape-memory or superelastic alloy such as nickel-titanium alloy. According to this embodiment, the size and/or shape of distal portion 136 may be predetermined by heat setting distal portion 136 to the desired diameter and length. Multiple embodiments of the invention incorporate alternate sizes and shapes of expansion member 132. For example, expansion member 132 may be heat set to expand so filter 111 has a larger diameter for one intervention and a smaller diameter for another.

Expansion member 132 may be completely or partially comprised of a radiopaque material. A radiopaque material is understood to be capable of producing a relatively bright image on a fluoroscopy screen or another imaging technique during a medical procedure. This relatively bright image aids the user of filter 111 in determining its location. Radiopaque materials may include gold, platinum, palladium, tantalum, tungsten alloy, and plastic material loaded with a radiopaque filler. Filter 111 and/or shaft 12 may further comprise additional radiopaque markers, similar to those known in the art.

It should be understood that this disclosure is, in many respects, only illustrative. Changes may be made in details, particularly in matters of shape, size, and arrangement of steps without exceeding the scope of the invention. The invention's scope is, of course, defined in the language in which the appended claims are expressed.

Claims

What is claimed is:

1. An intravascular filter apparatus, comprising:
an elongate shaft having a distal end;
a generally cylindrical filter coupled to the shaft near the distal end, the filter having a length and a diameter; and
wherein the diameter of the filter is larger than the length.
2. The filter apparatus in accordance with claim 1, wherein the shaft comprises a catheter having a lumen extending therethrough.
3. The filter apparatus in accordance with claim 2, wherein the lumen comprises an aspiration lumen coupled to the filter.
4. The filter apparatus in accordance with claim 1, further comprising an expansion member slidably disposed within the shaft.
5. The filter apparatus in accordance with claim 4, wherein the expansion member is comprised of a radiopaque material.
6. The filter apparatus in accordance with claim 4, wherein the expansion member includes a generally straight proximal portion and a generally coiled distal portion.
7. The filter apparatus in accordance with claim 6, wherein the distal portion is comprised of nickel-titanium alloy.
8. The filter apparatus in accordance with claim 1, wherein the length of the filter is less than about 0.10 inches.

9. The filter apparatus in accordance with claim 1, wherein the filter is collapsible within an outer tubular member.
10. The filter apparatus in accordance with claim 1, wherein the filter includes a filter frame that is comprised of a super-elastic alloy.
11. An intravascular filter apparatus, comprising:
an elongate shaft disposed within the outer sheath, the shaft having a proximal end and a distal end;
a disc-shaped filter frame coupled to the shaft near the distal end, the filter frame having a diameter and a filter material coupled thereto; and
means for aspirating embolic debris from the filter material.
12. The filter apparatus in accordance with claim 11, wherein the shaft comprises a catheter having a lumen extending therethrough and wherein means for aspirating embolic debris includes the lumen.
13. The filter apparatus in accordance with claim 11, further comprising means for expanding the filter.
14. The filter apparatus in accordance with claim 13, wherein means for expanding the filter includes an expansion member slidably disposed within the shaft.
15. The filter apparatus in accordance with claim 14, wherein the expansion member is comprised of a radiopaque material.

16. The filter apparatus in accordance with claim 14, wherein the expansion member includes a generally straight proximal portion and a generally coiled distal portion.

17. The filter apparatus in accordance with claim 16, wherein the distal portion is comprised of nickel-titanium alloy.

18. The filter apparatus in accordance with claim 11, wherein the length of the filter frame is less than about 0.10 inches.

19. The filter apparatus in accordance with claim 11, wherein the filter frame is comprised of a super-elastic alloy.

20. The filter apparatus in accordance with claim 11, wherein the filter is collapsible within an outer tubular member.

21. A method of filtering embolic debris from a blood vessel, comprising the steps of:

providing an elongate tubular member having a filter frame collapsed therein, the filter frame being coupled to an elongate shaft and having a filter material coupled thereto;

advancing the tubular member to an area of interest within a blood vessel of a patient;

moving the tubular member relative to the shaft so as to shift the filter frame from a generally collapsed configuration to a generally expanded configuration, wherein expanded the filter frame is generally cylindrical in shape and has a diameter and a length, the diameter being larger than the length;

performing an intravascular procedure that generates embolic debris;

capturing embolic debris with the filter material; and

aspirating the filter material.

22. The method in accordance with claim 21, wherein the shaft comprises a catheter having a lumen extending therethrough and wherein the step of aspirating the filter material includes aspirating embolic debris through the lumen.

23. A method of filtering embolic debris from a blood vessel, comprising the steps of:

providing an elongate shaft having a filter frame coupled thereto, the filter frame having a filter material coupled thereto, the shaft having an expansion member disposed therein;

advancing the shaft to an area of interest within a blood vessel of a patient;

actuating the expansion member so as to shift the filter frame from a generally collapsed configuration to a generally expanded configuration, wherein the expanded filter frame is generally cylindrical in shape and has a diameter and a length, the diameter being larger than the length;

performing an intravascular procedure that generates embolic debris;

capturing embolic debris with the filter material; and

aspirating the filter material.

24. The method in accordance with claim 23, wherein the shaft comprises a catheter having a lumen extending therethrough and wherein the step of aspirating the filter material includes aspirating embolic debris through the lumen.

25. The method in accordance with claim 23, wherein the expansion member includes a proximal portion and a distal portion, and wherein the step of actuating the expansion member includes applying force in the distal direction to the proximal portion.

26. An intravascular filter apparatus, comprising:

an elongate shaft disposed within the outer sheath;
a filter coupled to the shaft, the filter having a length that is sufficiently small to permit use thereof at the junction of a portion of the renal artery and a kidney; and
means for aspirating embolic debris from the filter.

27. An intravascular filter apparatus, comprising:
an elongate shaft disposed within the outer sheath;
a filter coupled to the shaft, the filter having a length that is sufficiently small to permit use thereof at the junction of a portion of the renal artery and a kidney;
means for aspirating embolic debris from the filter; and
means for shifting the filter between a generally collapsed configuration and a generally expanded configuration.

28. A method of filtering embolic debris from a the renal artery, comprising the steps of:
providing an elongate tubular member having a filter frame collapsed therein, the filter frame being coupled to an elongate shaft and having a filter material coupled thereto;
advancing the tubular member to the junction of a portion of the renal artery and a kidney;
retracting the tubular member relative to the shaft so as to shift the filter frame from a generally collapsed configuration to a generally expanded configuration, wherein expanded the filter frame is generally cylindrical in shape and has a diameter and a length, the diameter being larger than the length;
performing an intravascular procedure that generates embolic debris;
capturing embolic debris with the filter material; and
aspirating the filter material.

29. A method of filtering embolic debris from a the renal artery, comprising the steps of:

providing a elongate shaft having a filter frame coupled thereto, the filter frame having a filter material coupled thereto, the shaft having an expansion member disposed therein;

advancing the shaft to the junction of a portion of the renal artery and a kidney;

actuating the expansion member so as to shift the filter frame from a generally collapsed configuration to a generally expanded configuration, wherein expanded the filter frame is generally cylindrical in shape and has a diameter and a length, the diameter being larger than the length;

performing an intravascular procedure that generates embolic debris;

capturing embolic debris with the filter material; and

aspirating the filter material.

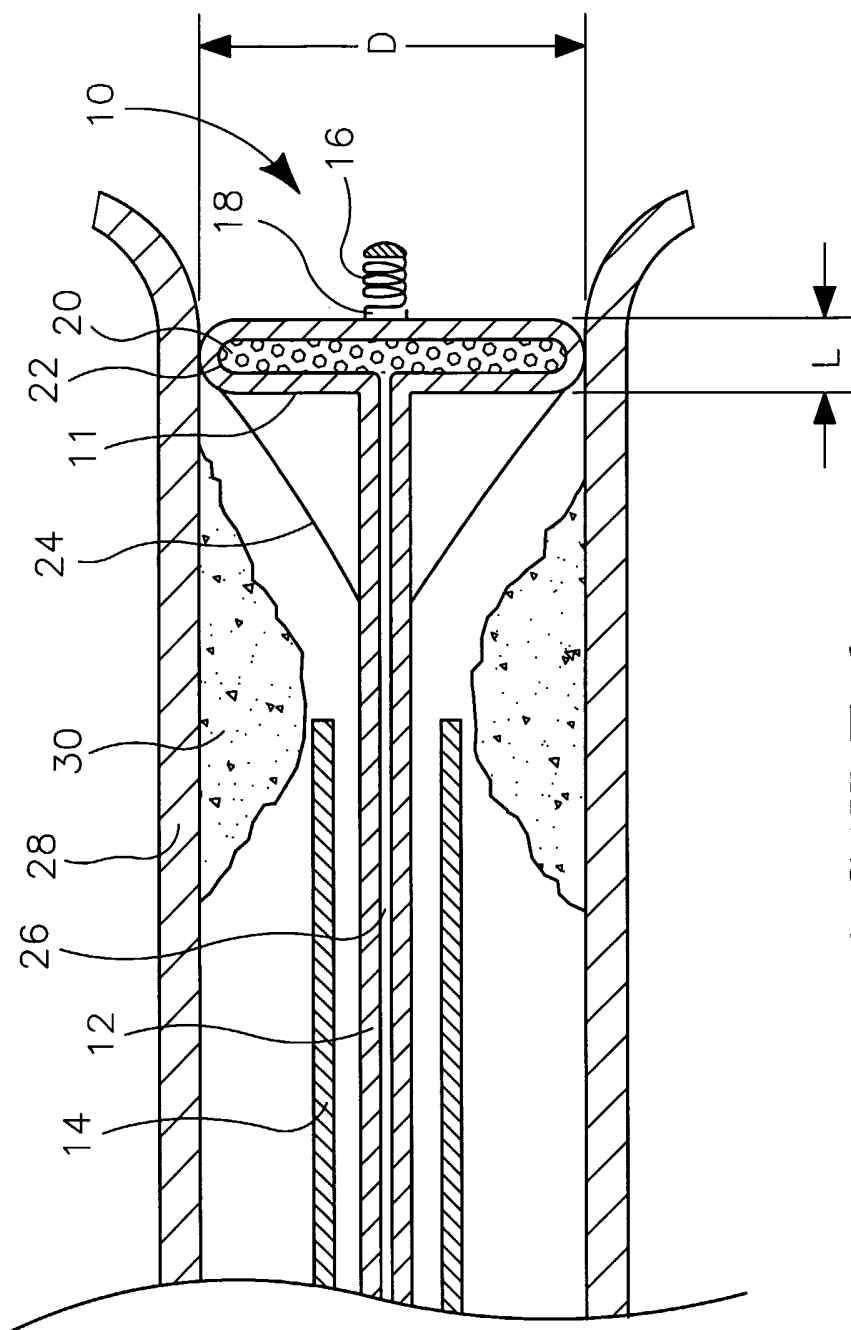

FIGURE 1

2/2

