

(No Model.)

W. J. KNOX.
DEVICE FOR OPERATING CHURNS.

No. 446,068.

Patented Feb. 10, 1891.

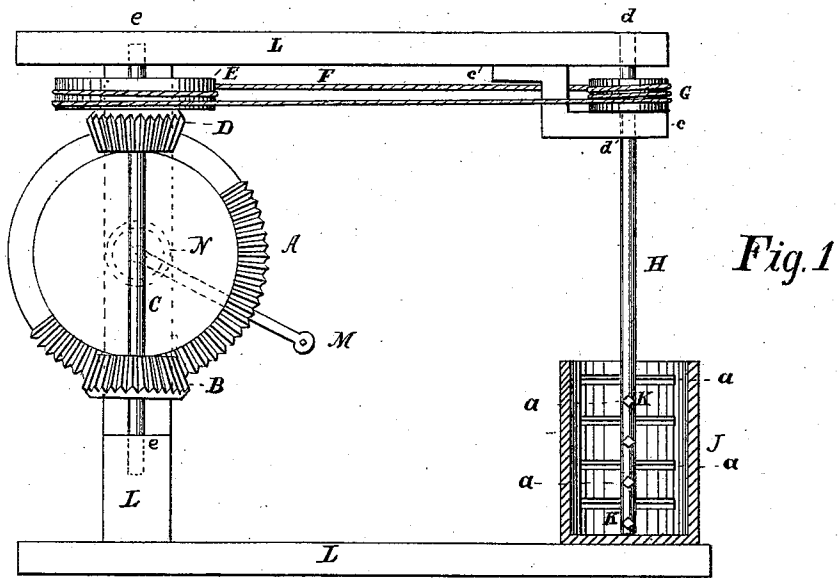

Fig. 1

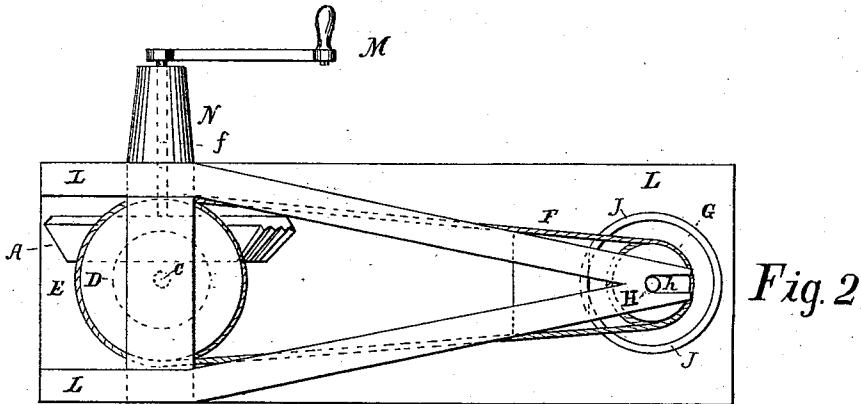

Fig. 2

Witnesses
Adelaide McHamilton
A. J. Willard

William J. Knox,
Inventor
by Charles W. King
Attorneys

UNITED STATES PATENT OFFICE.

WILLIAM J. KNOX, OF RICHLAND, MISSOURI.

DEVICE FOR OPERATING CHURNS.

SPECIFICATION forming part of Letters Patent No. 446,068, dated February 10, 1891.

Application filed May 7, 1890. Serial No. 350,948. (No model.)

To all whom it may concern:

Be it known that I, WILLIAM J. KNOX, a citizen of the United States, residing at Richland, in the county of Pulaski, State of Missouri, have invented new and useful Improvements in Devices for Operating Churns, of which the following is a specification.

My invention relates to the class in which a rotating shaft is employed; and the object of my invention is to give to the shaft rotary movement in opposite directions at successive intervals of time, so that after rotating in one direction a certain number of times it will be caused to rotate in an opposite direction for an equal number of times and continuously with the same alternation. I attain these objects by mechanism illustrated in the accompanying drawings, in which—

Figure 1 is a side elevation of the entire machine as seen from the side opposite to that on which the crank is placed. Fig. 2 is a plan as seen from above the machine.

Similar letters refer to similar parts throughout both views.

A is a beveled gear-wheel provided with cogs on its beveled face for a little less than half of its periphery, geared with the wheels B and D, rigidly attached to the vertical shaft C. The intended effect of this arrangement is that as the wheel A revolves it will successively engage with the gear-wheels B and D, causing them alternately to revolve in opposite directions.

L is a frame that supports parts already described and those to be described.

J is a vessel for holding the substance to be operated upon by means of the shaft H, and may be in any suitable form as in common use.

By connecting the shaft H with the motor-shaft C, as hereinafter described, it is made to take the same alternating motion as that described for the shaft C, by means of which the material is agitated in opposite directions in successive times.

For the purpose of communicating motion from the shaft C to the shaft H, I attach to the shaft C a pulley E and to the shaft H a pulley G, and connect the two shafts together

by the cord or band F, to which I preferably give two turns around the pulley E and three around the pulley G. The shaft C is journaled into the frame L at *e* and the shaft H into the same frame at *d*, and also into and through the supporting-piece *c*, securely attached to the frame L at *c*. A space is left above the pulley G and between it and the frame L for the purpose of holding the cord F when thrown off from the pulley G, as hereinafter explained. The pulley G is rigidly attached to the shaft H, which is firmly held in position at the bearings *d* and *d'*, and its lower side is given a slightly convex or conical form, so as to rest on the supporting-piece *c* to give support to that shaft where required without excess of friction.

The crank M is attached to the shaft *f*, which is rigidly attached to the gear-wheel A and passes through the elongated box N, to give it steadiness of motion.

In operation the cord is upon the pulley in the manner already described; but when it is desired to remove the shaft H from its bearings the cord F is slipped from the surface of the pulley G and left in the space above that pulley. For the purpose of enabling the shaft H to be removed from its position it is journaled at *d* and *d'* in a U-shaped recess, as shown in Fig. 2 at *h*, such recess opening in a direction opposite to the direction of the strain of the cord F when in operation. Like recesses are made for the same purpose in the frame L at *d* and in the supporting-piece *c* at *d'*. When the cord F is slack by being thrown off from the pulley G, the shaft H can be removed from the frame L.

What I claim as my invention, and desire to secure by Letters Patent, is—

The mutilated gear A, in combination with the gear-wheels B and D, shaft C, pulley E, cord F, shaft H, pulley G, and means for communicating motion to the wheel A, constructed and operating as hereinbefore set forth.

WILLIAM J. KNOX.

Witnesses:

J. G. BRANSTETTER,
H. M. COWAN.