

No. 619,087.

Patented Feb. 7, 1899.

H. O. PALMER.

DIE FOR MANUFACTURING OR SHARPENING STAR BIT ROCK DRILLS.

(Application filed June 13, 1898.)

(No Model.)

3 Sheets—Sheet 1.

Fig. 1.

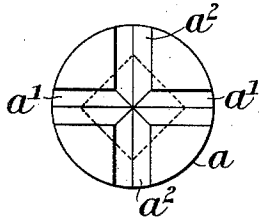

Fig. 2.

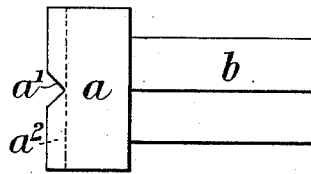

Fig. 3.

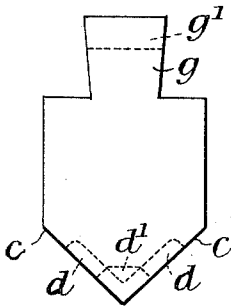
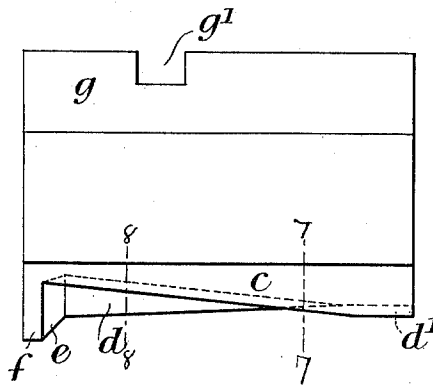

Fig. 4.



Witnesses.

G. F. Redfern
C. J. Redfern

Inventor.

H. O. Palmer

No. 619,087.

Patented Feb. 7, 1899.

H. O. PALMER.

DIE FOR MANUFACTURING OR SHARPENING STAR BIT ROCK DRILLS:

(Application filed June 13, 1898.)

(No Model.)

3 Sheets—Sheet 2.

Fig. 5.

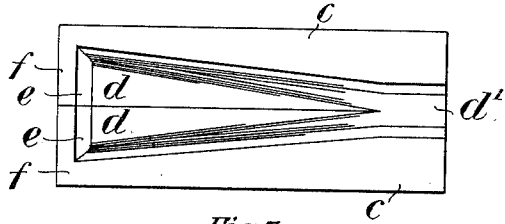

Fig. 7.

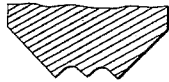

Fig. 8.

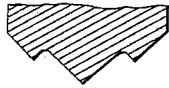

Fig. 9.

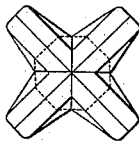
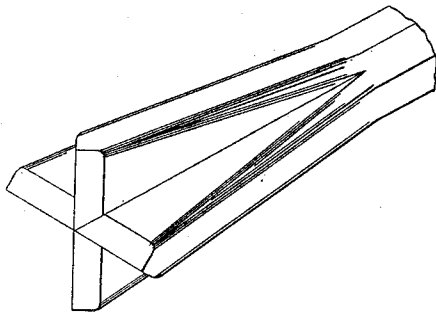

Fig. 10.



Witnesses.

J. D. Kinsley
B. S. [Signature]

Harry O. Palmer Inventor.
By Whitaker & Brewster Attys.

No. 619,087.

Patented Feb. 7, 1899.

H. O. PALMER.

DIE FOR MANUFACTURING OR SHARPENING STAR BIT ROCK DRILLS.

(Application filed June 13, 1898.)

(No Model.)

3 Sheets—Sheet 3.

Fig. 6.

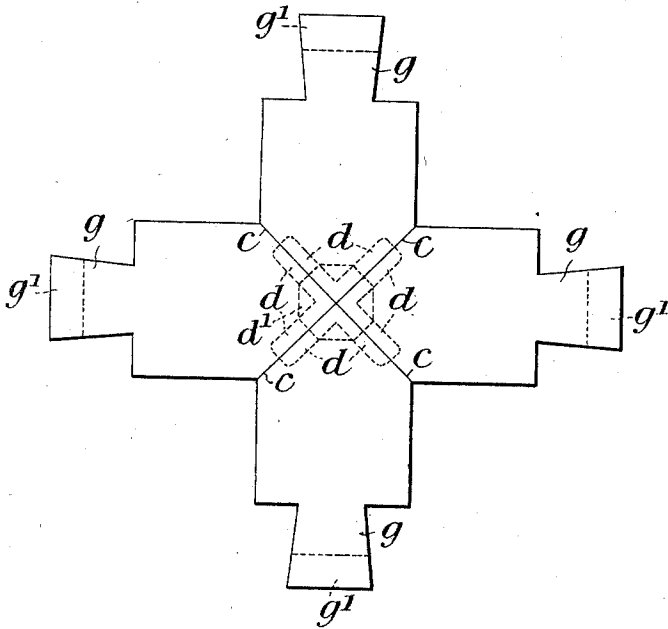

Witnesses

G. H. H. H.
C. G. H. H.

Inventor.

H. O. Palmer

UNITED STATES PATENT OFFICE.

HARRY OWEN PALMER, OF BOLTON, ENGLAND.

DIE FOR MANUFACTURING OR SHARPENING STAR-BIT ROCK-DRILLS.

SPECIFICATION forming part of Letters Patent No. 619,087, dated February 7, 1899.

Application filed June 13, 1898. Serial No. 683,283. (No model.)

To all whom it may concern:

Be it known that I, HARRY OWEN PALMER, a citizen of the United States of America, residing at Bolton, England, have invented new and useful Improvements in Dies for the Manufacture or Sharpening of Star-Bit Rock-Drills, (for which I have applied for a patent in Great Britain, No. 26,557, dated November 13, 1897,) of which the following is a specification.

This invention relates to improvements in dies for the manufacture or sharpening of star-bit rock-drills used by miners and others, the said invention comprising a novel construction of die for fluting or grooving the bar of steel from which the drill is to be formed.

The steel bar from which the drill is to be forged is held by suitable grippers and four dies are simultaneously moved toward each other, so that they act with equal effect upon the faces of the said bar until the end thereof is sufficiently grooved or fluted to form the star-bit drill. In conjunction with the four dies I employ what I term a "dolly-tool"—that is to say, a tool having V-shaped grooves crossing one another, the said tool being caused to impinge against the shaped end which the said four dies are in process of making in the intervals between the blows of the said dies.

In the accompanying drawings, Figure 1 is a face view of the dolly-tool which I employ, and Fig. 2 is a side elevation thereof. Figs. 3, 4, and 5 are an end view, a side view, and an under side view, respectively, of one of my dies; and Fig. 6 is a view showing the manner in which the four dies produce the star-bit drill. Fig. 7 represents a section on line 7 7, Fig. 4. Fig. 8 represents a section on line 8 8, Fig. 4. Fig. 9 is an end view of the drill formed by my improved dies. Fig. 10 is a perspective view of the same.

a is the block forming the working face of the dolly-tool, the said block a being provided with a shank b , by means of which it can be held in a suitable holder, and with grooves $a^1 a^2$, which cross one another, as shown.

Figs. 3, 4, and 5 are three views of one of the novel dies employed for forging or sharpening the star-bit rock-drill. The said die is formed with a beveled working face, the an-

gle between the two surfaces $c c$ forming the bevel being ninety degrees, as clearly shown. The two said faces $c c$ are recessed, as shown at $d d$, the said recesses having their maximum depth at the outer end of the die and gradually becoming less until they die away to form the recess d' for the shank of the tool, as clearly shown in Figs. 4 and 5. The deep end of each recess d is formed with a bevel e , which is designed, as hereinafter described, to form the beveled edge of the drill, and the outer end of each face c of the die is formed with a parallel edge f , as seen in Figs. 4 and 5.

Each die is provided with a shank g , which has a slot g' for enabling it to be rigidly secured in a suitable holder.

To forge a star-bit rock-drill by means of the improved dies hereinbefore described, the heated steel bar from which the tool is to be forged is held in suitable grippers and the four dies, which are arranged at right angles in the manner indicated in Fig. 6, are caused by suitable mechanism to move simultaneously toward one another, so that their working beveled edges strike the faces of the bar and by repeated blows gradually force the metal into the grooves $d d$ in the faces $c c$ of the said dies. Between the successive blows of the said dies the dolly-tool a is caused to descend upon the outer end of the steel bar, thereby forming the beveled cutting edges of the star-bit drill. The dies are continued in operation until they have completely formed the star-bit drill, as shown in Fig. 6. The same operation is performed for sharpening or repairing a drill.

Having now particularly described and ascertained the nature of my said invention and in what manner the same is to be performed, I declare that what I claim is—

1. Dies for manufacturing or sharpening star-bit rock-drills, each die having a beveled working face formed of two surfaces at right angles to one another and each surface having a recess which gradually dies away from its maximum depth at the outer end of the die, the said deep end of the recess being beveled transversely to the axis of the die, substantially as hereinbefore described.

2. The described die having the inclined

faces *c, c* provided with recesses *d, d* which are beveled at *e, e* and the shank *g* provided with the slot *g'*, substantially as described and illustrated.

- 5 3. The combination with a dolly-tool comprising a block or body with a suitable shank and having two V-shaped grooves crossing one another, of four dies each having a beveled working face formed of two surfaces at right

angles to one another and each surface having a recess which gradually dies away from its maximum depth at the outer end of the die, the said deep end of the recess being beveled, substantially as hereinbefore described.

HARRY OWEN PALMER.

Witnesses:

G. F. REDFERN,
C. G. REDFERN.