

- [54] **MOP HAVING A HOLDER WITH CLAMPING JAWS**
- [72] Inventor: **Julian I. Saltzstein**, Cleveland, Tenn.
- [73] Assignee: **American Uniform Company**, Cleveland, Tenn.
- [22] Filed: **June 7, 1971**
- [21] Appl. No.: **150,296**
- [52] U.S. Cl. .... **15/229 A, 15/150, 223/96**
- [51] Int. Cl. .... **A47I 13/252**
- [58] Field of Search ..... **15/115, 147 R, 147 C, 148, 15/150, 152, 173, 177, 228, 229 A; 223/90, 96**

*Primary Examiner*—Daniel Blum  
*Attorney*—Prangley, Clayton, Mullin, Dithmar & Vogel

[57] **ABSTRACT**

A mop holder for holding a mop head and a mop handle, the mop holder comprising a one-piece construction of a rod shaped to provide a first pair of clamping arms and a second pair of clamping arms moveable between an open position thereof and a clamping position thereof. A lever is pivotally connected to the first pair of clamping arms and is shiftable between an unlatched position thereof and a latched position thereof to move the pairs of clamping arms from the open position thereof wherein a mop may be inserted therebetween to the clamping position thereof wherein the mop head is firmly clamped therebetween. A casting may be provided for holding the mop handle, the casting being connected to a pair of third clamping arms extending from the one-piece construction, and a sleeve may be provided surrounding the casting and the pair of third clamping arms firmly to hold the mop handle within the one-piece construction.

[56] **References Cited**

UNITED STATES PATENTS

16,137	12/1856	Allen.....	15/150
409,777	8/1889	Duhamel.....	223/96
3,220,040	11/1965	Knaebe.....	15/147 R X

**19 Claims, 11 Drawing Figures**

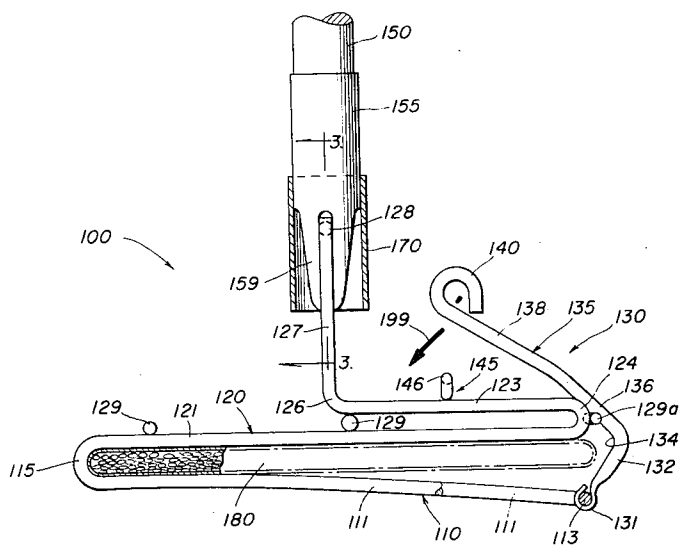

FIG. 1

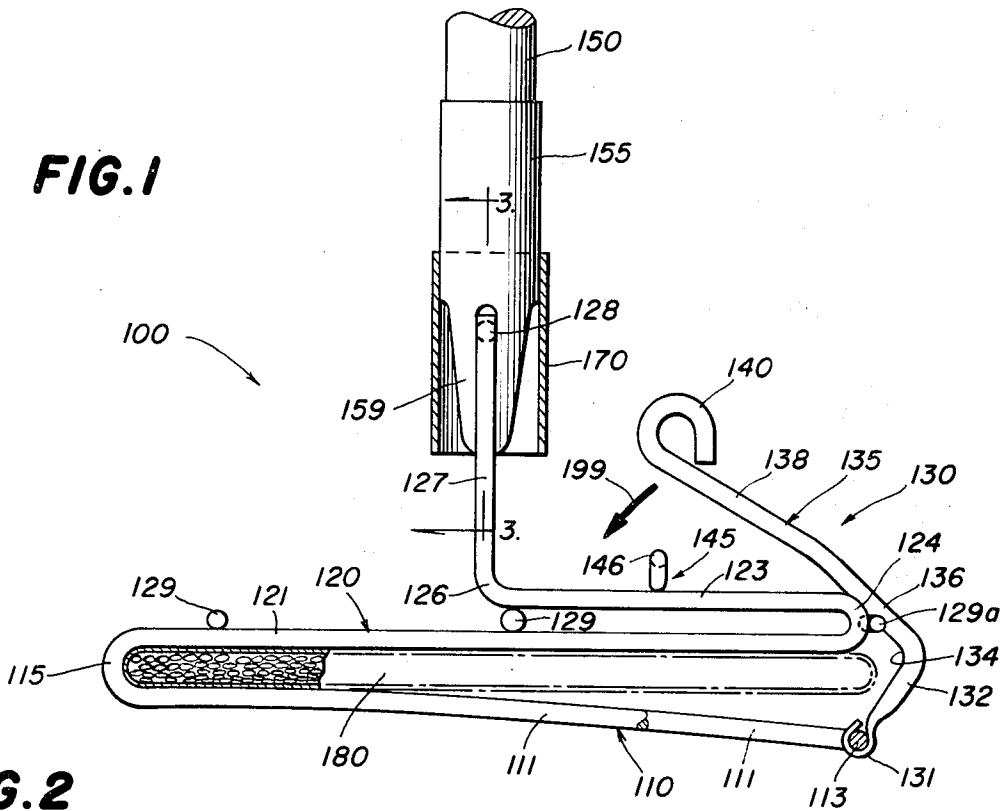

FIG. 2

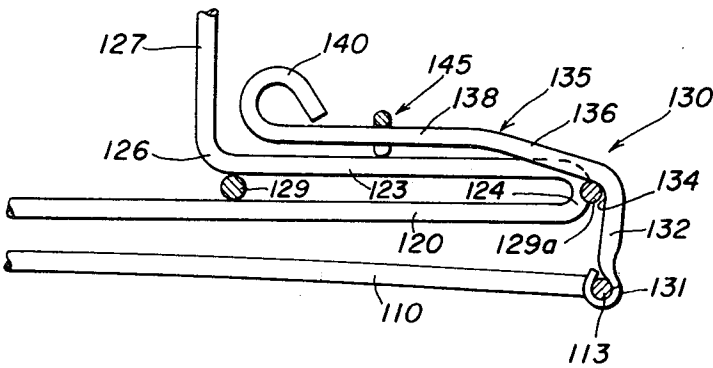

FIG. 3

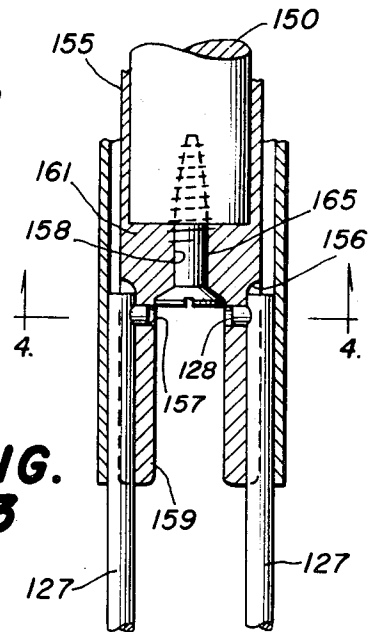
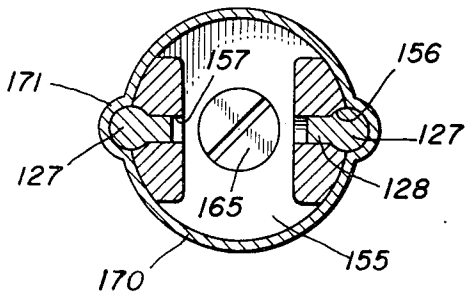
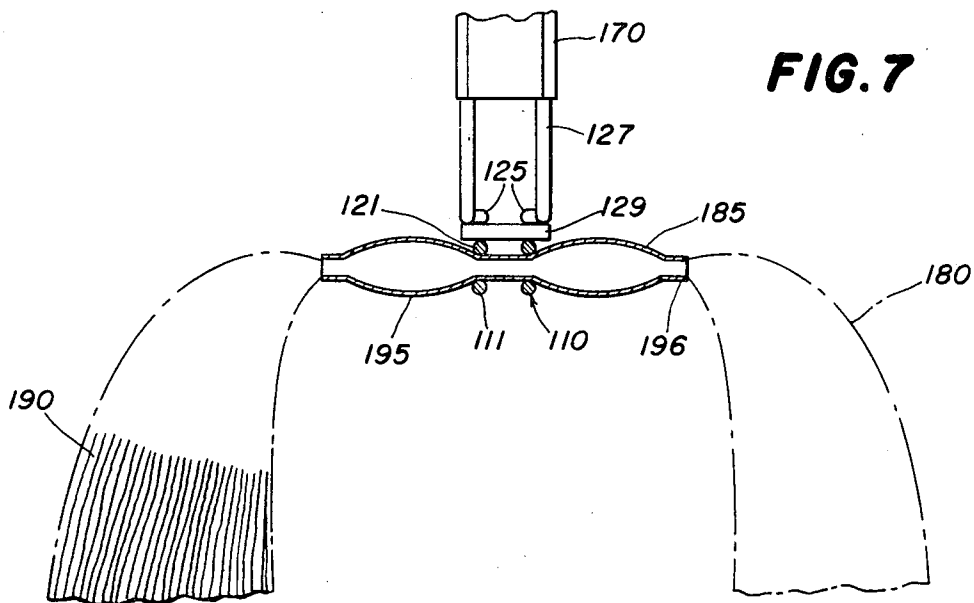
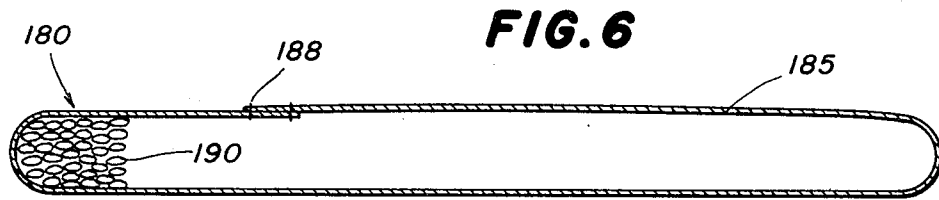
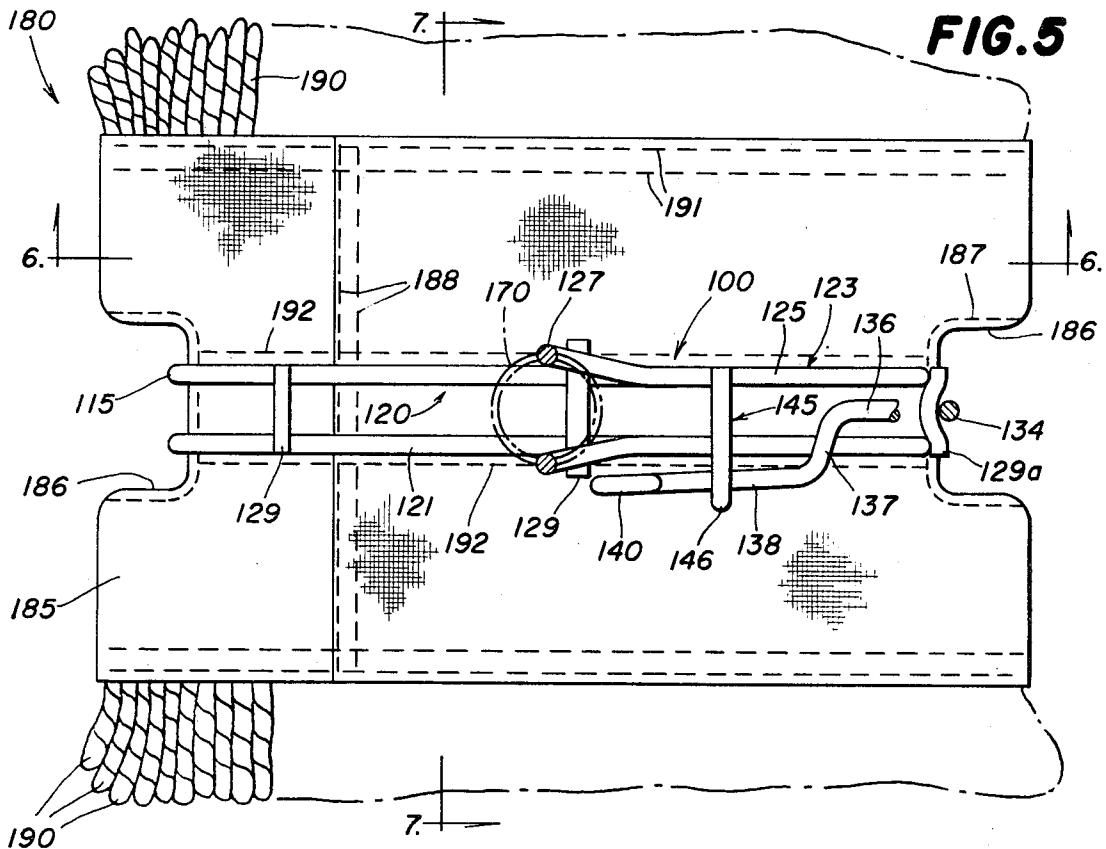

FIG. 4



INVENTOR  
JULIAN I. SALTZSTEIN

BY  
*Trangley, Clayton, Mullin,*  
*Ditchman & Vogel* ATTYS.



**FIG. 8**

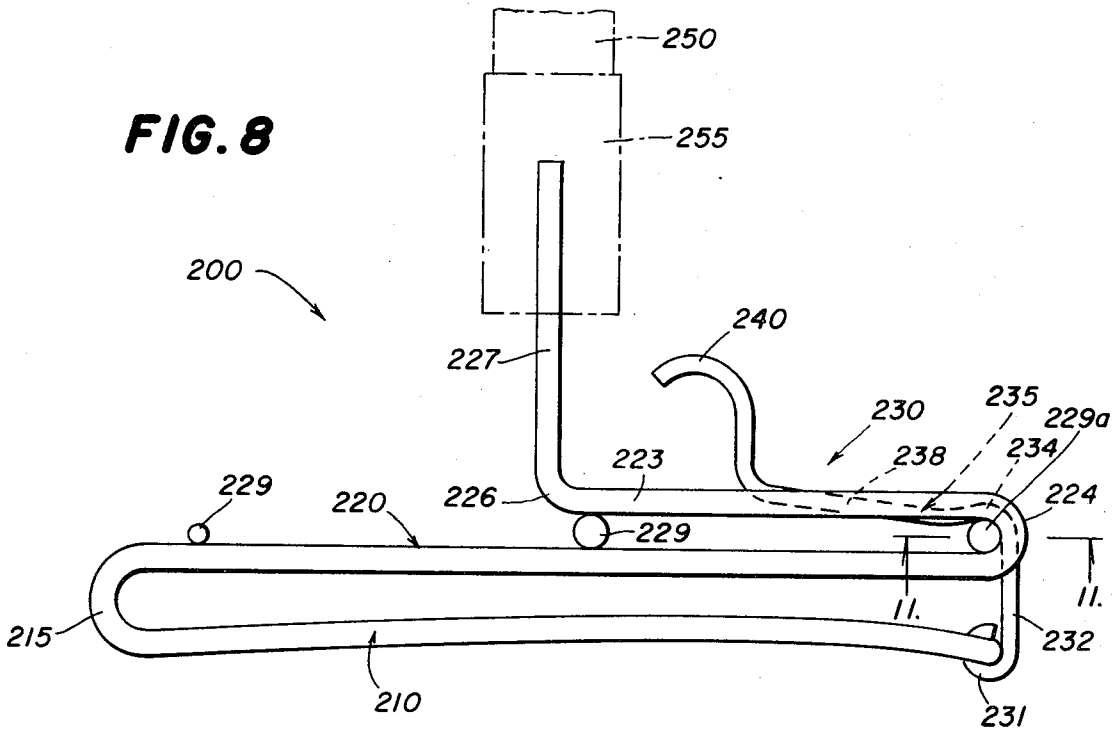

**FIG. 9**

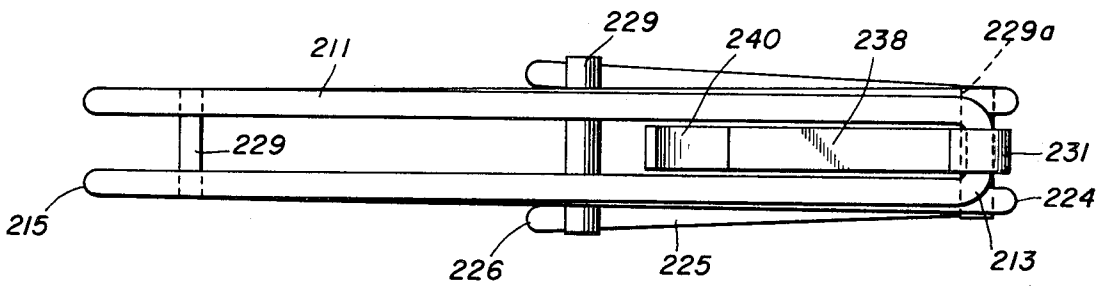

**FIG. 10**

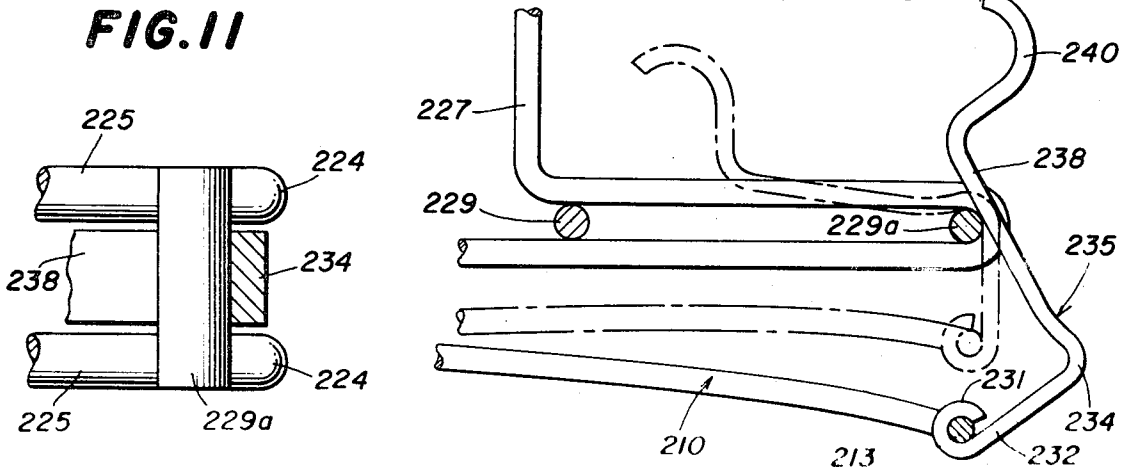

**FIG. 11**

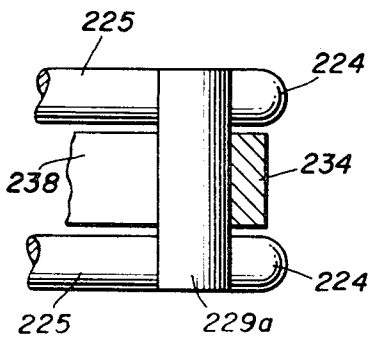

**MOP HAVING A HOLDER WITH CLAMPING JAWS**

This invention is directed to a mop holder for use with a mop head, and particularly to a mop holder including a one-piece construction shaped to provide first and second pairs of clamping arms.

It is an important object of the present invention to provide a mop holder comprising a one-piece construction of a rod shaped to provide a pair of first spaced-apart longitudinally clamping arms joined by a first U-shaped connection at one end thereof and a pair of second spaced-apart longitudinally extending clamping arms, each of the first longitudinally extending clamping arms having at the other end thereof a second U-shaped connection integral with one end of one of the second longitudinally extending clamping arms, the pair of second longitudinally extending arms extending in the same general direction from the second U-shaped connection as the pair of first longitudinally extending clamping arms, the one-piece construction being resilient and accommodating movement of the pairs of first and second longitudinally extending clamping arms between an open position thereof wherein the first U-shaped connection is disposed away from the other end of the second longitudinally extending arms and a clamping position thereof wherein the first U-shaped connection is disposed toward the other end of the second longitudinally extending arms, the pairs of first and second longitudinally extending clamping arms in the open position thereof easily accommodating placement of a mop head therebetween so as to position the pair of first clamping arms on one side of the mop head and the pair of second clamping arms on the other side of the mop head, a lever pivotally connected to the first U-shaped connection on the pair of first clamping arms and pivotable between a latched position thereof and an unlatched position thereof, and a latch on the other ends of the pair of second longitudinally extending clamping arms and cooperating with the lever to maintain the lever in the latched position thereof, whereby movement of the lever from the unlatched position thereof to the latched position thereof provides movement of the pair of spaced-apart first longitudinally extending clamping arms and the pair of spaced-apart second longitudinally extending clamping arms between the open position thereof and the clamping position thereof firmly to clamp the mop head displaced therebetween.

Another object of the present invention is to provide an improved mop holder of the type set forth in which the one-piece construction includes pair of resilient third spaced-apart longitudinally extending clamping arms and accommodating movement between an open position thereof wherein the ends of the pair of third longitudinally extending clamping arms away from the third U-shaped connections are spaced apart and a closed position thereof wherein the pair of third longitudinally extending clamping arms are disposed toward one another, the pair of third longitudinally extending clamping arms in the open position thereof easily accommodating placement of a mop handle therebetween and in the closed position thereof firmly holding the mop handle therebetween in a position substantially normal to the pairs of first and second longitudinally extending clamping arms.

Still another object of the present invention is to provide a mop holder of the type set forth in which a plu-

ality of support bars are provided extending transversely of the pair of the second longitudinally extending clamping arms and connecting the same with one of the support bars interconnecting the pair of second longitudinally extending clamping arms at the other ends thereof.

A further object of the present invention is to provide a combination of a mop holder of the type set forth and a mop head in which the mop head has a web in the center thereof adapted to fit between the lever and the second U-shaped connection and adapted firmly to be clamped between the pair of first longitudinally extending clamping arms and the pair of second longitudinally extending clamping arms.

The invention, both as to its organization and method of operation, together with further objects and advantages thereof, will be understood by reference to the following specification taken in connection with the accompanying drawings in which:

FIG. 1 is a side elevational view partly in section of the mop holder of the present invention having a mop handle connected thereto and a mop disposed between the pairs of first and second longitudinally extending arms thereof, and showing the arms in the open position thereof and the lever in the unlatched position thereof;

FIG. 2 is a side elevational view of the right-hand portion of FIG. 1 showing the lever in the latched position thereof and the pairs of first and second clamping arms in the clamping position thereof;

FIG. 3 is an enlarged sectional view of the mop handle holding mechanism illustrated in FIG. 1 taken along line 3—3 thereof;

FIG. 4 is a sectional view of the mop handle holding mechanism illustrated in FIG. 3 taken along line 4—4 thereof;

FIG. 5 is a plan view of the mop head and mop holder of the present invention;

FIG. 6 is a sectional view of the mop head illustrated in FIG. 5 taken along line 6—6 thereof;

FIG. 7 is a sectional view of the mop head and mop holder of the present invention illustrated in FIG. 5 taken along line 7—7 thereof;

FIG. 8 is a side elevation view of another embodiment of the mop holder of the present invention showing the pairs of first and second clamping arms in the clamping position thereof and the lever in the latched position thereof;

FIG. 9 is a bottom elevational view of the embodiment of the mop holder of the present invention illustrated in FIG. 8;

FIG. 10 is a side elevational view of the mop holder illustrated in FIG. 8 showing in full line the pairs of first and second clamping arms in the open position thereof and the lever in the unlatched position thereof and in phantom line the pairs of first and second clamping arms in the clamping position thereof and the lever in the latched position thereof; and

FIG. 11 is a sectional view of the mop holder illustrated in FIG. 8 taken along line 11—11 thereof.

The mop holder 100 of the present invention includes a one-piece construction shaped to provide a pair of first clamping arms 110, a pair of second clamping arms 120 and a pair of third clamping arms 123, the pair of third clamping arms 123 have upstanding ends

127 adapted to hold a mop handle 150 therebetween. A casting 155 and a sleeve 170 may be provided firmly to connect the mop handle 150 to the mop holder 100. A special mop head 180 is adapted securely to fit between the pair of first clamping arms 110 and the pair of second clamping arms 120.

With reference to the drawings and particularly to FIGS. 1 through 4 thereof, there is shown the mop holder 100 of the present invention including a one-piece construction of a rod shaped to provide the pair of first spaced-apart longitudinally extending clamping arms 110, each of the arms 110 being in the shape of a rod 111 and connected at one end thereof by a first U-shaped connection 113, see the right-hand end of FIG. 1. The rods 111 lie in substantially the same horizontal plane, although the rods 111 are curved somewhat. At the other end of the pair of first clamping arms 110, each of the arms 111 is formed into a second U-shaped connection 115 each of which leads to a rod 121 of the pair of second spaced-apart longitudinally extending clamping arms 120. Each of the rods 111 and the corresponding rod 121 lie in substantially the same vertical plane, while the rods 121 lie in substantially the same horizontal plane. As may be seen, the pair of second longitudinally extending clamping arms 120 extends in the same direction from the second U-shaped connections 115 as do the pair of first longitudinally extending clamping arms 110.

Each of the rods 121 of the pair of second clamping arms 120 extends from the second U-shaped connection 115 to a third U-shaped connection 124 integrally connecting the pair of second longitudinally extending clamping arms 120 with the pair of third clamping arms 123. The pair of third clamping arms 123 includes a pair of spaced-apart rods a portion 125 of which extend parallel to the plane formed by the rods 121 of the pair of second longitudinally extending clamping arms 120 and a portion 127 of which extend perpendicularly to the plane formed by the rods 121. The rods 125 and the rods 127 are each connected respectively by elbow connections 126. The rods 125 extending from the third U-shaped connections 124 to the elbow connections 126 lie in substantially the same horizontal plane. Each of the rods 125 lies in substantially the same vertical plane as the respective ones of rods 111 and rods 121.

The upstanding rods 127 of the pair of third clamping arms 123 each carry a stud 128 on the inside thereof for a reason hereinafter set forth. Each of the upstanding rods 127 of the pair of third clamping arms 123 diverges outwardly from the elbows 126 also for a purpose hereinafter to be disclosed.

Finally, the pair of second clamping arms 120 is provided with a plurality of support bars 129 extending transversely of the rods 121 and being longitudinally spaced apart and securely fastened to each of the rods 121 such as by welding. A sinuously shaped support bar 129a is located at the right-hand end of the rods 121 of the pair of second clamping arms 120 (as seen in FIGS. 1 and 2) and acts as a fulcrum for a purpose hereinafter set forth.

Referring now particularly to FIGS. 1 and 5, there is seen a lever 130 having a pivot loop 131 positioned around the first U-shaped connection 113 interconnecting the rods 111 of the pair of first clamping arms

110. Extending from the pivot loop 131 of the lever 130 is a short arm 132 and a long arm 135 connected thereto as at notch 134, the long arm 135 forming an acute angle with the short arm 132. The long arm 135 has a bearing portion 136 and an offset portion 137 and a latching portion 138, all for a purpose hereinafter to be explained. The lever 130 is formed into a handle 140 at the end thereof away from the pivot loop 131. Attached to the rods 125 of the pair of third clamping arms 123 is a latch member 145 having a portion thereof 146 raised above the plane formed by the rods 125, the portion 146 being for engaging the latching portion 138 of the lever 130 in a manner hereinafter to be explained. The latch member 145 fixedly is secured to the rods 125 of the pair of third clamping arms 123 as by welding.

As seen, therefore, the rods 11 of the pair of first clamping arms 110, the rods 121 of the pair of second clamping arms 120, and the rods 125 and upstanding rods 127 of the pair of third arms 123 all form a one-piece construction, with at least the pair of first clamping arms 110 and the rods 127 of the pair of third arms 123 being resilient.

As seen particularly in FIGS. 1, 3 and 4, the mop handle 150 is positioned within the casting 155, which casting 155 is cylindrical in shape with downwardly extending portions 159, each of which has a slot 156 therein to receive a respective one of the upstanding rods 127 of the pair of third arms 123. The casting 155 further includes two apertures 157, one each being formed within each of the slots 156. Each of the apertures 157 receive therein one of the studs 128 extending inwardly from the upstanding rods 127 of the pair of third arms 123.

The casting 155 has a central aperture 158 at the bottom thereof extending through a seat 161 of the casting 155 for receiving the bottom of the mop handle 150, the aperture 158 providing communication between the seat 161 of the casting 155 and the area between the downwardly extending portions 159 carrying therein the slots 156. A screw 165 is adapted to fit within the aperture 158 and to be screwed into the seated end of the mop handle 150 thereby fixedly to secure the mop handle 150 within the casting 155. The tubular sleeve 170 fits over the upstanding rods 127 of the pair of third arms 123 and the casting 155 securely to position the upstanding rods 127 within the slots 156 of the casting 155. The sleeve 170 has opposed bosses 171 therein to accommodate the upstanding rods 127 of the pair of third arms 123, all as best seen in FIG. 4.

Referring now to FIGS. 5, 6 and 7, there is illustrated the mop head 180 of the present invention, which mop head 180 includes a web 185 having two opposed cut-outs 186, the cut-outs 186 resulting in the web 185 fitting snugly between the second U-shaped connections 115 at one end of the pair of first clamping arms 110 and the notch 134 of the lever 130 pivotally connected to the first U-shaped connection 113. As best seen in FIG. 6, the web 185 is a single sheet of material joined as at 188 by double stitching to provide for additional strength, the web 185 also having stitching 187 around each of the cut-outs 186 and double stitching 191 where the shag 190 is joined to the web 185. Referring to FIG. 7 it is seen that a central portion of the web 185 formed by the longitudinal seams 192 is of reduced

thickness to provide for easier clamping between the pair of first clamping arms 110 and the pair of second clamping arms 120. The mop head 180 has a puffed portion 195 outwardly of the central portion defined by the seams 192 and a gathered section 196 at the outermost ends of the web 185 to provide for more secure locking of the shag 190 within the web 185.

Operation of the mop holder 100 will now be explained. Referring now to FIGS. 1 and 2 of the drawings, there is shown in FIG. 1 the mop holder 100 of the present invention in which the pair of first clamping arms 110 and the pair of second clamping arms 120 are in the open position thereof so as to accommodate therebetween the mop head 180. When the mop head 180 is in position, as shown in FIG. 5, the lever 130 is moved from its unlatched position as shown in FIG. 1 in the direction of the arrow 199 to its latched position as shown in FIG. 2, thereby moving the pair of first clamping arms 110 and the pair of second clamping arms 120 to the clamping position thereof firmly to clamp the mop head 180 therebetween.

As the lever 130 is moved from its unlatched position (FIG. 1) to its latched position (FIG. 2), the bearing surface 136 thereof bears against the right-handmost support bar 129a which acts as a fulcrum for the lever 130. As the lever 130 is advanced to the left as shown in FIG. 1, the mechanical advantage of the lever 130 is increased due to the relative lengths of the long arm 135 and the short arm 132. When the lever 130 reaches its latched position, the offset portion 138 is shifted sideways to fit under the raised portion 146 of the latch 145, thereby to maintain the lever 130 in its latched position. When the lever 130 is in the latched position thereof and the pairs of first and second clamping arms 110 and 120 are in the clamping position thereof, the mop head 180 is held firmly therebetween, the convex shape of the pair of first clamping arms 110 maintaining the mop holder 100 away from the floor surface on which the mop head 180 will rest in the use position thereof.

As seen particularly in FIG. 7, the spaced apart rods 111 of the pair of first clamping arms 110 and the spaced apart rods 121 of the pair of second clamping arms 120 provide spaced apart lines of support for the web 185 of the mop head 180 in order securely to position the mop head 180 within the mop holder 100. Additionally, the mop handle 150 is positioned within the casting 155 and the sleeve 170, as hereinbefore explained, thereby to provide a useful combination of the mop handle 150, the mop holder 100 and the mop head 180.

A second embodiment of the present invention is shown in FIGS. 8 to 11 of the drawings in which like reference numerals in the 200 series have been applied to like parts of the mop holder 100 previously discussed. As disclosed in FIG. 8 of the drawings there is shown a mop holder 200 including a one-piece construction shaped to provide a pair of first clamping arms 210 which is formed of two spaced apart rods 211 interconnected by a first U-shaped connection 213, see the right-handmost portion of FIG. 9, and at the other end of the pair of first clamping arms 210, each of the rods 211 is provided with a second U-shaped connection 215 leading to one of a pair of second clamping arms 220. The pair of second clamping arms 220 is

formed of two spaced apart rods, each of which extends from one of the second U-shaped connections 215 to a pair of third arms 223 interconnected with the pair of second arms 220 by means of two third-shaped connections 224, one in each of the rods 221.

The pair of third arms 223 is formed of two spaced apart rods 225, each of which extends in an outwardly diverging direction from the third U-shaped connections 224 to an elbow bend 226 in each of the rods 225. The elbow bend 226 in each of the rods 225 connect an outwardly extending and upstanding rod 227 to each of the rods 225 of the pair of third arms 223. Each of the upstanding rods 227 of the pair of third arms 223 has a stud (not shown) to cooperate with a mop handle 250 and casting 255 shown in phantom in FIG. 8. The pair of second clamping arms 220 is provided with a plurality of support bars 229 extending transversely of the rods and being securely fastened thereto such as by welding, the right-handmost support bar 229a, as seen in FIG. 8, acting as a fulcrum for a lever 230 as hereinafter explained.

The lever 230 is provided at one end thereof with a pivot loop 231 which extends around the first U-shaped connection connecting the pair of first clamping arms 210. The lever 230 further includes a short arm 232 and a long arm 235 interconnected by a notch portion 234. The long arm 235 has a bearing portion 238 thereon and terminates in a loop-shaped handle 240 at the other end of the lever from the pivot loop 231. As seen, therefore, the rods 211 of the pair of first clamping arms 210, and the rods 225 and upstanding rods 227 of the pair of third arms 223 all form a one-piece construction with at least the pair of first clamping arms 210 and the rods 227 of the pair of third arms 223 being resilient.

Operation of the mop holder 200 is similar to operation of the mop holder 100 except that the notch 234 in the lever arm 230 is more pronounced so as to provide for retention of the lever 230 in the latched position thereof, as shown in phantom in FIG. 10, without the need of the latch 145 shown in FIG. 1. In FIG. 10, there is illustrated the lever 230 in the unlatched position thereof (full line) and the lever 230 in the latched position thereof (phantom line) to correspond with the pairs of first and second clamping arms 210 and 220 in the open position thereof (full line) and in the clamping position thereof (phantom line). The lever 230 is moved from its unlatched position its latched position in the same manner as is lever 130, the lever 230 also providing increasing mechanical advantage as it is moved to the left in FIG. 10. The bearing surface 238 bears against the fulcrum 229a so as to move the pairs of clamping arms 210 and 220 from the open position thereof to the clamping position thereof while providing increased mechanical advantage and easier movement of the lever 230.

In view of the foregoing, it is apparent that there has been provided an improved mop holder and combination of the mop holder and mop head for use with an associated mop handle, the mop holder having a one-piece construction shaped to provide a pair of first clamping arms and a pair of second clamping arms integrally connected and a lever pivotally connected to the pair of first clamping arms and shiftable between an unlatched position thereof and a latched position

thereof to provide movement of the pair of first clamping arms and the pair of second clamping arms between the open position thereof and the clamping position thereof.

While there has been described what at present is considered to be the preferred embodiment of the invention, it will be understood that various modifications may be made therein and it is intended to cover in the appended claims all such modifications as fall within the true spirit and scope of the invention.

What is claimed is:

1. A mop holder comprising a one-piece construction of a rod shaped to provide a pair of first spaced-apart longitudinally extending clamping arms joined by a first U-shaped connection at one end thereof and a pair of second spaced-apart longitudinally extending clamping arms, each of said first longitudinally extending clamping arms having at the other end thereof a second U-shaped connection integral with one end of one said second longitudinally extending clamping arms, said pair of second longitudinally extending clamping arms extending in the same general direction from said second U-shaped connections as said pair of first longitudinally extending clamping arms, said one-piece construction being resilient and accommodating movement of said pairs of first and second longitudinally extending clamping arms between an open position thereof wherein said first U-shaped connection is disposed away from the other ends of said second longitudinally extending arms and a clamping position thereof wherein said first U-shaped connection is disposed toward the other ends of said second longitudinally extending arms, said pairs of first and second longitudinally extending clamping arms in the open position thereof easily accommodating placement of a mop head therebetween so as to position said pair of first clamping arms on one side of the mop head and said pair of second clamping arms on the other side of the mop head, a lever pivotally connected to said first U-shaped connection on said pair of first clamping arms and pivotable between a latched position thereof, and an unlatched position thereof, and a latch on said other ends of said pair of second longitudinally extending clamping arms and cooperating with said lever to maintain said lever in the latched position thereof, whereby movement of said lever from the unlatched position thereof to the latched position thereof provides movement of said pair of spaced-apart first longitudinally extending clamping arms and said pair of spaced-apart second longitudinally extending clamping arms between the open position thereof and the clamping position thereof firmly to clamp the mop head disposed therebetween.

2. The mop holder set forth in claim 1, wherein said first U-shaped connection joining said pair of first clamping arms is spaced from said other ends of said pair of second clamping arms a distance farther than said other end of said pair of first clamping arms is spaced from said one end of said pair of second clamping arms when said pairs of first and second longitudinally extending clamping arms are in the open position thereof.

3. The mop holder set forth in claim 1, wherein said pair of second clamping arms have means connected thereto for bearing against said lever during movement

of said lever from the unlatched position to the latched position thereof.

4. The mop holder set forth in claim 1, wherein said lever includes a short arm pivotally connected to said first U-shaped connection and a long arm extending from said short arm, said long arm providing for increased mechanical advantage for said lever as said lever is moved from the unlatched position thereof to the latched position thereof.

5. The mop holder set forth in claim 1, wherein said lever includes a notch therein for bearing against said latch when said lever is in the latched position thereof to maintain said latch in the latched position thereof.

6. The mop holder set forth in claim 1, wherein said lever has a handle attached to the end thereof.

7. The mop holder set forth in claim 1, wherein the end of said lever away from the pivotal connection to said first U-shaped connection is formed into a U-shaped handle to provide for easy movement of said lever between the unlatched position thereof and the latched position thereof.

8. A mop holder comprising, a one-piece construction of a rod shaped to provide a pair of first spaced-apart longitudinally extending clamping arms joined by a first U-shaped connection at one end thereof and a pair of second longitudinally extending spaced-apart clamping arms and a pair of third spaced-apart longitudinally extending clamping arms, each of said first longitudinally extending clamping arms having at the other end thereof a second U-shaped connection integral with one end of one of said second longitudinally extending clamping arms, said pair of second longitudinally extending clamping arms extending in the same general direction from said second U-shaped connections as said pair of first longitudinally extending clamping arms, each of said second longitudinally extending clamping arms having at the other end thereof a third U-shaped connection integral with one end of one of said third longitudinally extending clamping arms, a portion of said pair of third longitudinally extending clamping arms extending in a direction substantially normal to said pairs of first and second longitudinally extending clamping arms, said one-piece construction being resilient and accommodating movement of said pairs of first and second longitudinally extending clamping arms between an open position thereof wherein said first U-shaped connection is disposed away from the other ends of said second longitudinally extending arms and a clamping position thereof wherein said first U-shaped connection is disposed toward the other ends of said second longitudinally extending arms, said pairs of first and second longitudinally extending clamping arms in the open position thereof easily accommodating placement of a mop head therebetween so as to position said pair of first clamping arms on one side of the mop head and said pair of second clamping arms on the other side of the mop, said pair of third longitudinally extending clamping arms being resilient and accommodating movement between an open position thereof wherein the ends of said pair of third longitudinally extending clamping arms away from said third U-shaped connections are spaced apart and a closed position thereof wherein said pair of third longitudinally extending clamping arms are disposed toward one another, said

pair of third longitudinally extending clamping arms in the open position thereof easily accommodating placement of a mop handle therebetween and in the closed position thereof firmly holding the mop handle therebetween in a position substantially normal to said pairs of first and second longitudinally extending clamping arms, a lever pivotally connected to said first U-shaped connection on said pair of first clamping arms and pivotable between a latched position thereof and an unlatched position thereof, and a latch on said other ends of said pair of second longitudinally extending clamping arms and cooperating with said lever to maintain said lever in the latched position thereof, whereby movement of said lever from the unlatched position thereof to the latched position thereof provides movement of said pair of spaced-apart first longitudinally extending clamping arms and said pair of spaced-apart second longitudinally extending clamping arms between the open position thereof and the clamping position thereof firmly to clamp the mop head disposed therebetween.

9. The mop holder set forth in claim 8, wherein said pair of third clamping arms diverge outwardly from said third U-shaped connections.

10. The mop holder set forth in claim 8, wherein the portion of said pair of third clamping arms disposed normally to said pairs of first and second clamping arms is resilient.

11. The mop holder set forth in claim 8, wherein each of said third longitudinally extending clamping arms extending normally to said pair of said first and second clamping arms carries thereon a stud, said stud being disposed to cooperate with a casting shaped to support one end of the mop handle, said casting having opposed outwardly extending portions each of said portions having a longitudinal groove therein to accommodate a respective one of said third longitudinally extending clamping arms, each of said longitudinally extending grooves having an aperture to accommodate one of said studs and a sleeve having opposed bosses therein to fit over said casting and said pair of third longitudinally extending clamping arms positioned in said grooves, so as firmly to position the mop handle associated with said sleeve and said casting between said pair of third clamping arms in a position substantially normal to said pair of first and second clamping arms.

12. A mop holder comprising a one-piece construction of a rod shaped to provide a pair of first spaced-apart longitudinally extending clamping arms joined by a first U-shaped connection at one end thereof and a pair of second spaced-apart longitudinally extending clamping arms, each of said first longitudinally extending clamping arms having at the other end thereof a second U-shaped connection integral with one end of one of said second longitudinally extending clamping arms, said pair of second longitudinally extending clamping arms extending in the same general direction from said second U-shaped connections as said pair of first longitudinally extending clamping arms, a plurality of support bars extending transversely of said pair of said second longitudinally extending clamping arms and connecting the same with one of said support bars interconnecting said pair of second longitudinally extending clamping arms at the other ends thereof, said one-piece construction being resilient and accom-

modating movement of said pairs of first and second longitudinally extending clamping arms between and open position thereof wherein said first U-shaped connection is disposed away from said other ends of said second longitudinally extending arms and a clamping position thereof wherein said first U-shaped connection is disposed toward the other ends of said second longitudinally extending arms, said pairs of first and second longitudinally extending clamping arms in the open position thereof easily accommodating placement of a mop head therebetween so as to position said pair of first clamping arms on one side of the mop head and said pair of second clamping arms on the other side of the mop, a lever pivotally connected to said first U-shaped connection on said pair of first clamping arms and pivotable between a latched position thereof and an unlatched position thereof, and a latch coupled to said other ends of said pair of second longitudinally extending clamping arms and cooperating with said lever to maintain said lever in the latched position thereof, whereby movement of said lever from the unlatched position thereof against said support bar at said other ends of said second longitudinally extending clamping arms to the latched position thereof provides movement of said pair of spaced-apart first longitudinally extending clamping arms and said pair of spaced-apart second longitudinally extending clamping arms between the open position thereof and the clamping position thereof firmly to clamp the mop head disposed therebetween.

13. The mop holder set forth in claim 12, wherein each of said support bars is firmly welded to each of said second clamping arms.

14. The mop holder set forth in claim 12, wherein the one of said support bars interconnecting said pair of second longitudinally extending clamping arms at the other ends thereof acts as a fulcrum for said lever during the movement thereof between the unlatched position thereof and the latched position thereof.

15. The mop holder set forth in claim 12, wherein the one of said support bars interconnecting said pair of second longitudinally extending clamping arms at the other ends thereof is sinuously shaped and acts as a fulcrum for said lever during the movement thereof between the unlatched position thereof and the latched position thereof.

16. In combination a mop head and a mop holder, said mop holder comprising, a one-piece construction of a rod shaped to provide a pair of first spaced-apart longitudinally extending clamping arms joined by a first U-shaped connection at one end thereof and a pair of second spaced-apart longitudinally extending clamping arms, each of said first longitudinally extending clamping arms having at the other end thereof a second U-shaped connection integral with one end of one of said second longitudinally extending clamping arms, said pair of second longitudinally extending clamping arms extending in the same general direction from said second U-shaped connections as said pair of first longitudinally extending clamping arms, said one-piece construction being resilient and accommodating movement of said pairs of first and second longitudinally extending clamping arms between an open position thereof wherein said first U-shaped connection is disposed away from the other ends of said second lon-

gitudinally extending arms and a clamping position thereof wherein said first U-shaped connection is disposed toward the other ends of said second longitudinally extending arms, said pairs of first and second longitudinally extending clamping arms in the open position thereof easily accommodating placement of said mop head therebetween so as to position said pair of first clamping arms on one side of the mop head and said pair of second clamping arms on the other side of the mop, a lever pivotally connected to said first U-shaped connection on said pair of first clamping arms and pivotable between a latched position thereof and an unlatched position thereof, and a latch on said other ends of said pair of second longitudinally extending clamping arms and cooperating with said lever to maintain said lever in the latched position thereof, said mop head having a web in the center thereof adapted to fit between said lever and said second U-shaped connections, whereby movement of said lever from the un-

5  
10  
15  
20  
25  
30  
35  
40  
45  
50  
55  
60  
65

latched position thereof to the latched position thereof provides movement of said pair of spaced-apart first longitudinally extending clamping arms and said pair of spaced-apart second longitudinally extending clamping arms between the open position thereof and the clamping position thereof firmly to clamp said mop head disposed therebetween.

17. The combination set forth in claim 16, wherein said web has two cut-outs so as to fit snugly between said lever and said second U-shaped connection.

18. The combination set forth in claim 16, wherein said mop head has double stitching along the juncture of said web and the shag of said mop head.

19. The combination set forth in claim 16, wherein said web has a reduced thickness for the portion thereof fitting between said pairs of first and second clamping arms.

\* \* \* \* \*

UNITED STATES PATENT OFFICE  
CERTIFICATE OF CORRECTION

Patent No. 3,688,331 Dated September 5, 1972

Inventor(s) Julian I. Saltzstein

It is certified that error appears in the above-identified patent and that said Letters Patent are hereby corrected as shown below:

Column 7, line 21, Claim 1-after one insert --of--;

Column 9, line 54, Claim 12 - delete "an" and insert  
--extending--.

Signed and sealed this 9th day of January 1973.

(SEAL)  
Attest:

EDWARD M. FLETCHER, JR.  
Attesting Officer

ROBERT GOTTSCHALK  
Commissioner of Patents