



US 20030163882A1

(19) **United States**

(12) **Patent Application Publication**  
**Blaustein et al.**

(10) **Pub. No.: US 2003/0163882 A1**

(43) **Pub. Date: Sep. 4, 2003**

(54) **ELECTRIC TOOTHBRUSHES**

**Related U.S. Application Data**

(75) Inventors: **Lawrence A. Blaustein**, Moreland Hills, OH (US); **Douglas A. Gall**, Strongsville, OH (US); **Patrick W. Brown**, Auburn, OH (US)

(60) Provisional application No. 60/361,625, filed on Mar. 4, 2002.

**Publication Classification**

(51) **Int. Cl.<sup>7</sup>** ..... **A61C 17/34**  
(52) **U.S. Cl.** ..... **15/22.2; 15/22.1; 15/28**

Correspondence Address:

**THE PROCTER & GAMBLE COMPANY**  
**INTELLECTUAL PROPERTY DIVISION**  
**WINTON HILL TECHNICAL CENTER - BOX 161**  
**6110 CENTER HILL AVENUE**  
**CINCINNATI, OH 45224 (US)**

**ABSTRACT**

(57) An electric toothbrush is provided. The electric toothbrush includes a handle having an electric motor, a head, and a neck extending between the handle and the head. The head has first end disposed adjacent to the neck and a second end opposite the first end. The head has a first bristle holder with a plurality of bristles disposed therein and a second bristle holder having a plurality of bristles disposed therein. The first bristle holder is located at the second end of said head. A rotating shaft is operatively connected to the electric motor and to the first moving bristle holder to reciprocate the first moving bristle holder in a direction transverse to a longitudinal axis of the head.

(73) Assignee: **The Procter & Gamble Company**

(21) Appl. No.: **10/308,959**

(22) Filed: **Dec. 3, 2002**

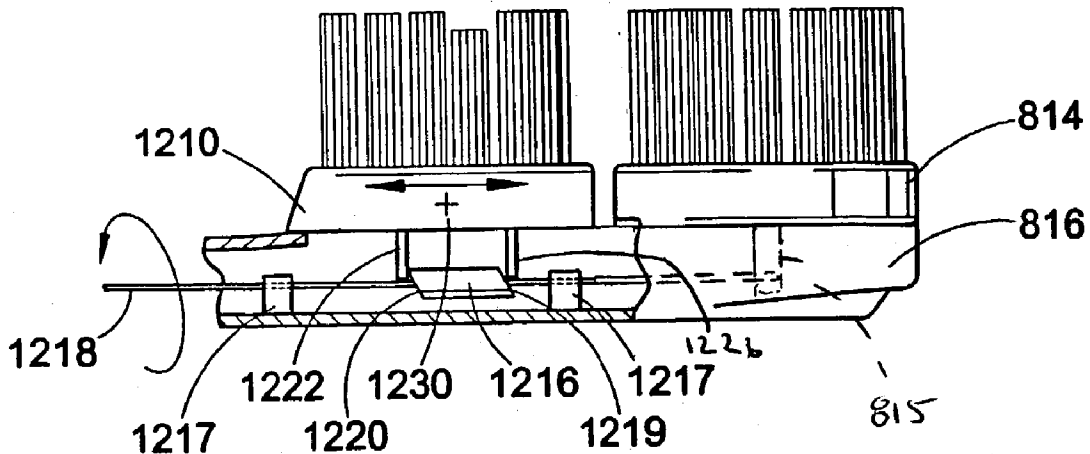

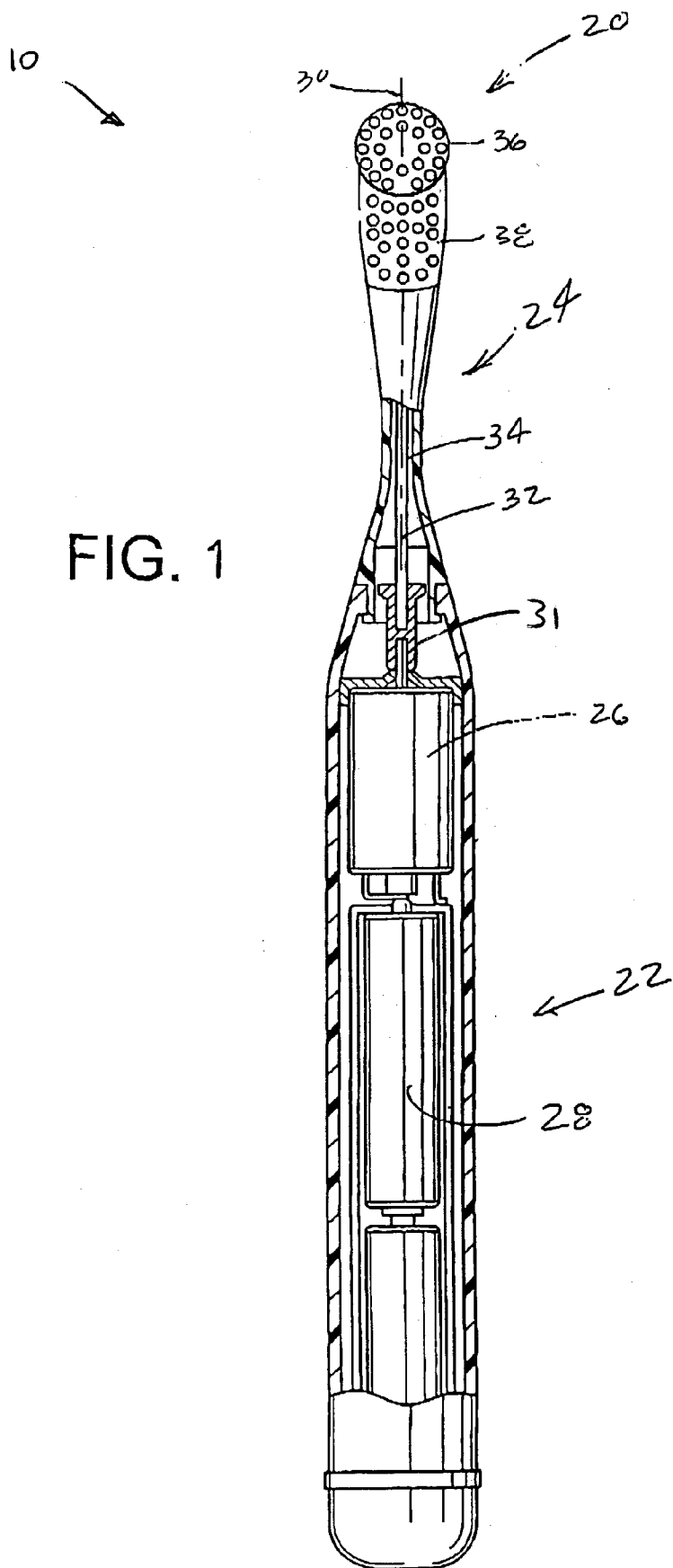

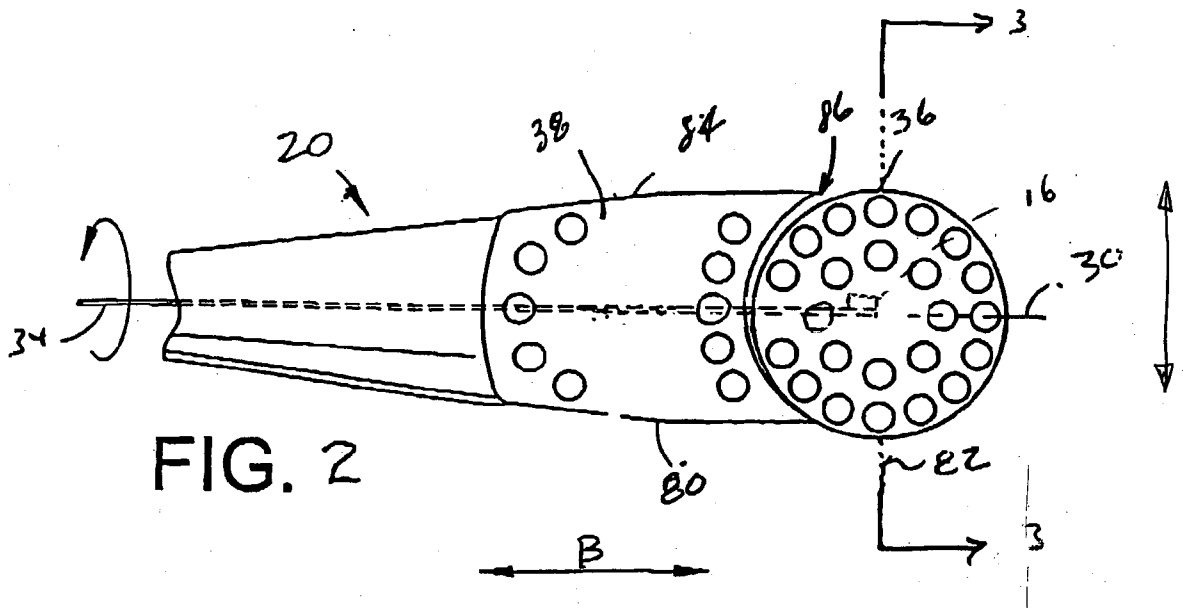

FIG. 2

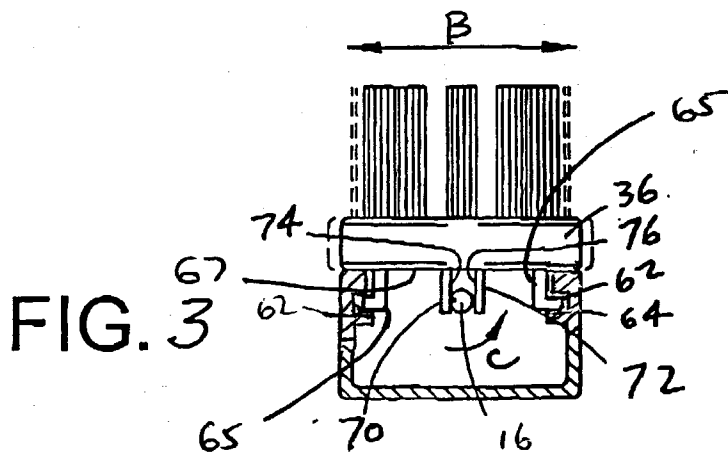
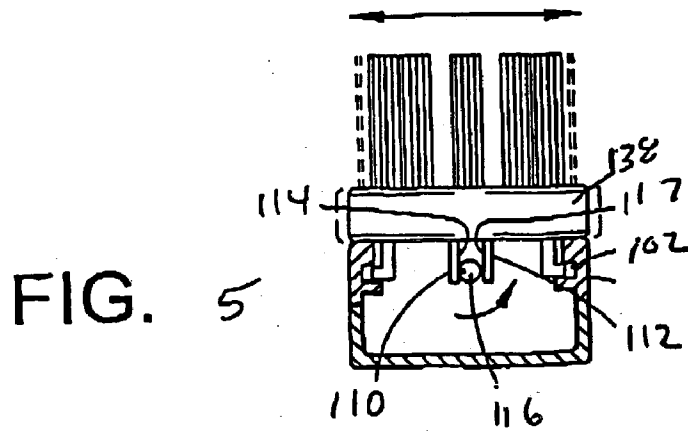
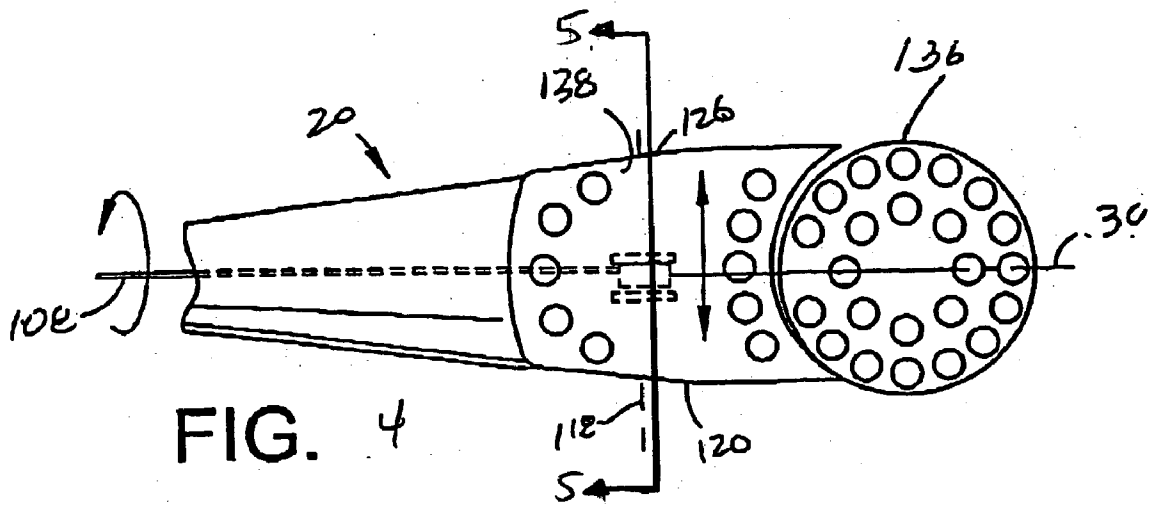

FIG. 3



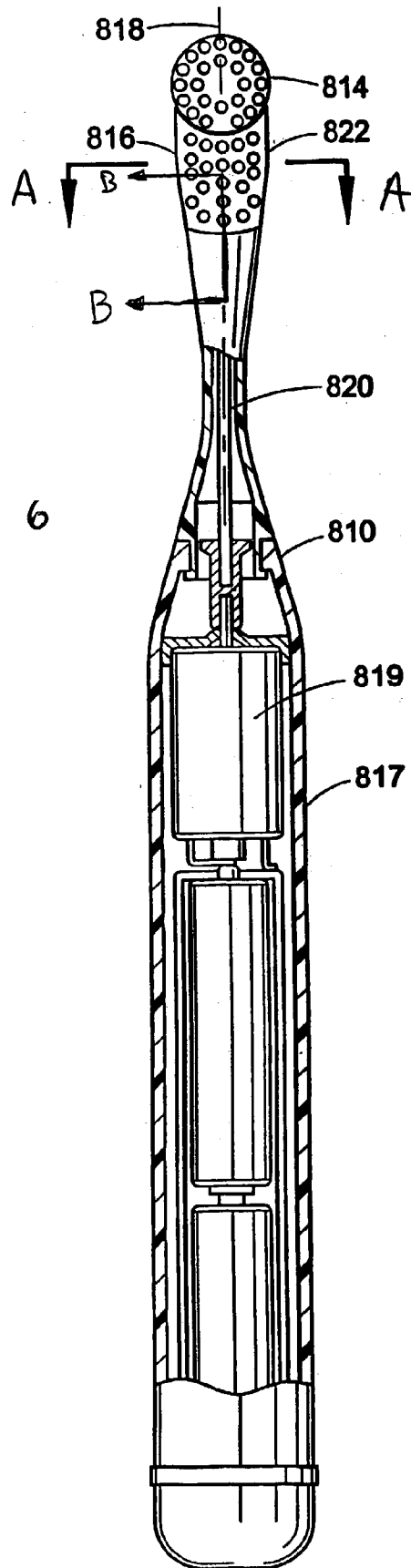

FIG. 6

FIG. 7

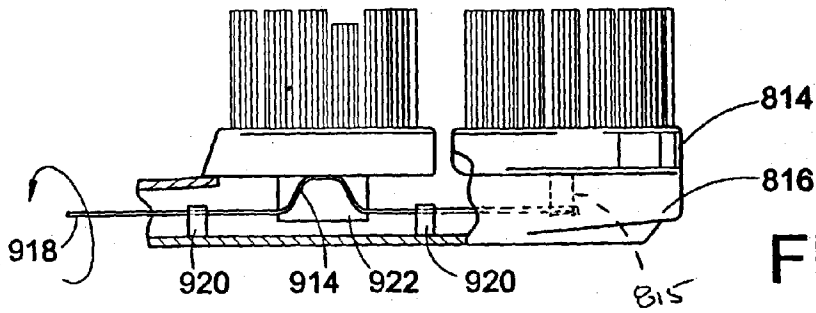
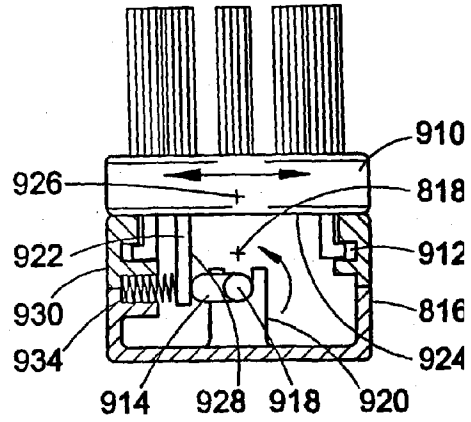

FIG. 7A

FIG. 8

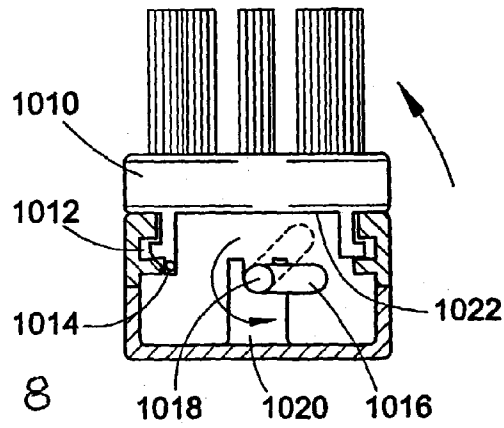
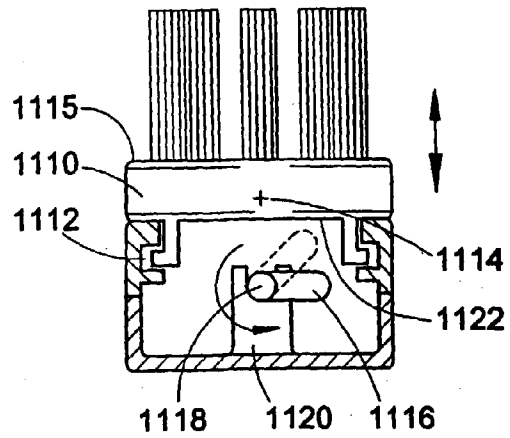

FIG. 9



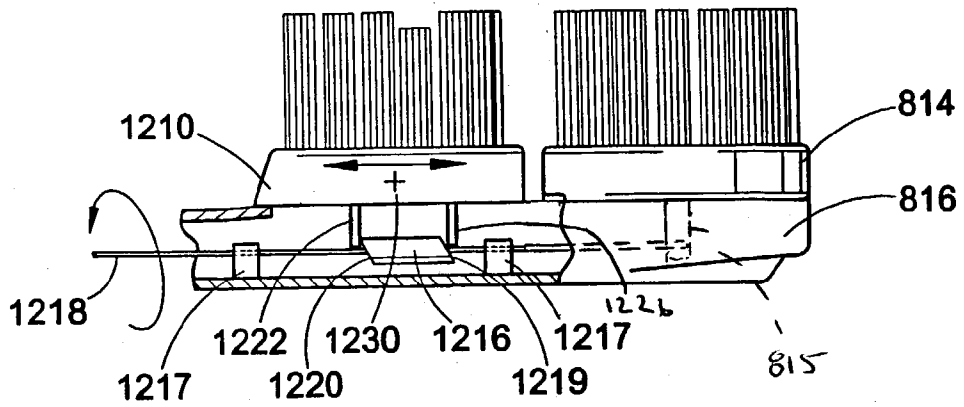

FIG. 10

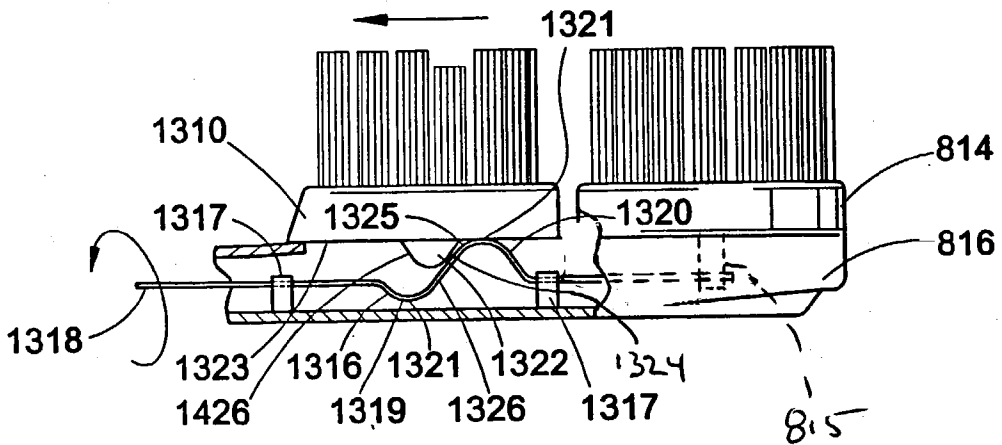

FIG. 11

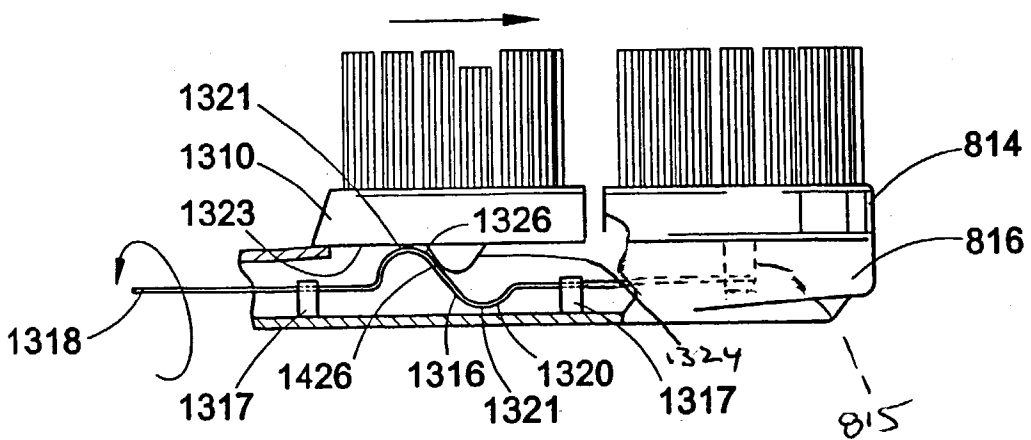

FIG. 12

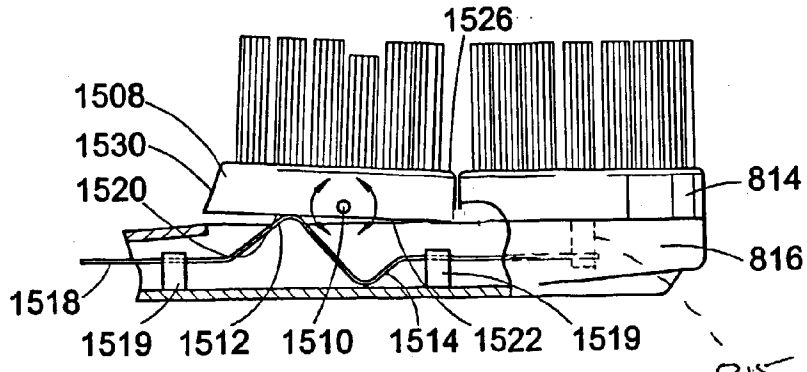

FIG. 13

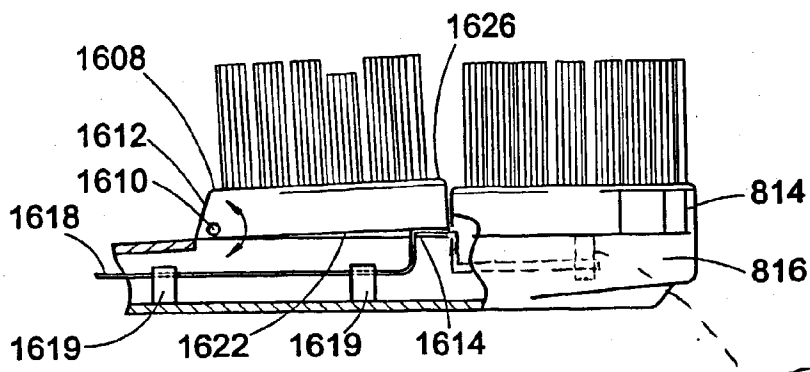

FIG. 14

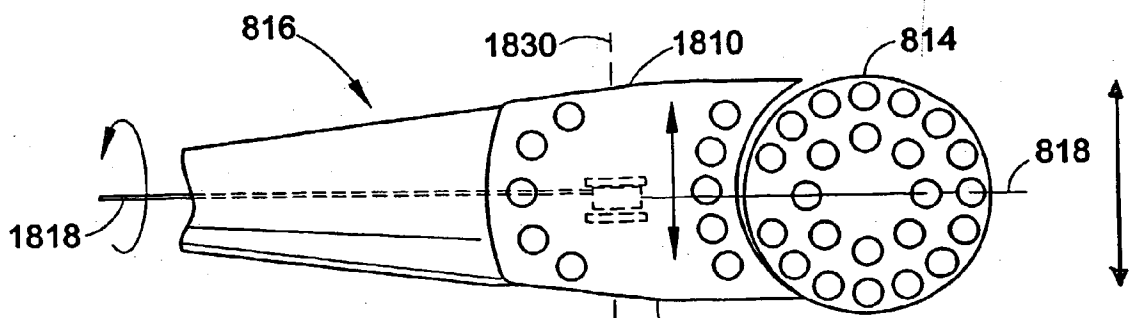

FIG. 15

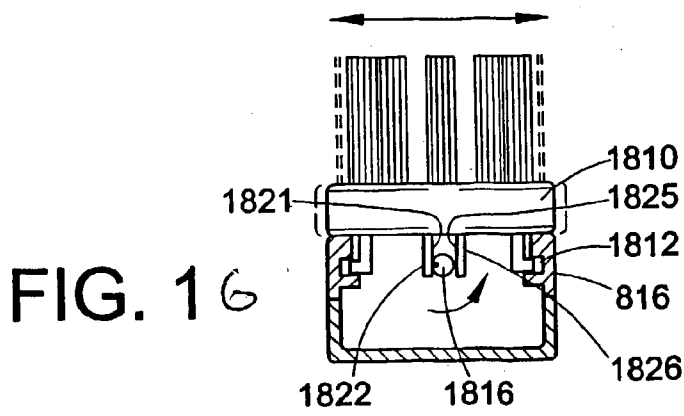

FIG. 16



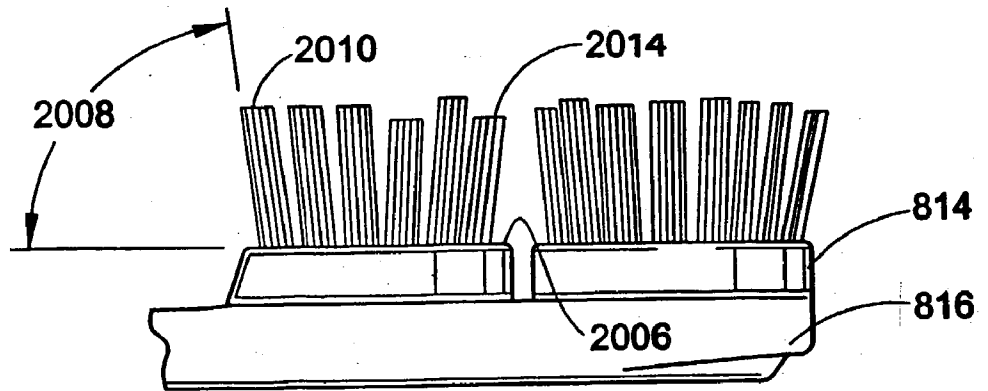
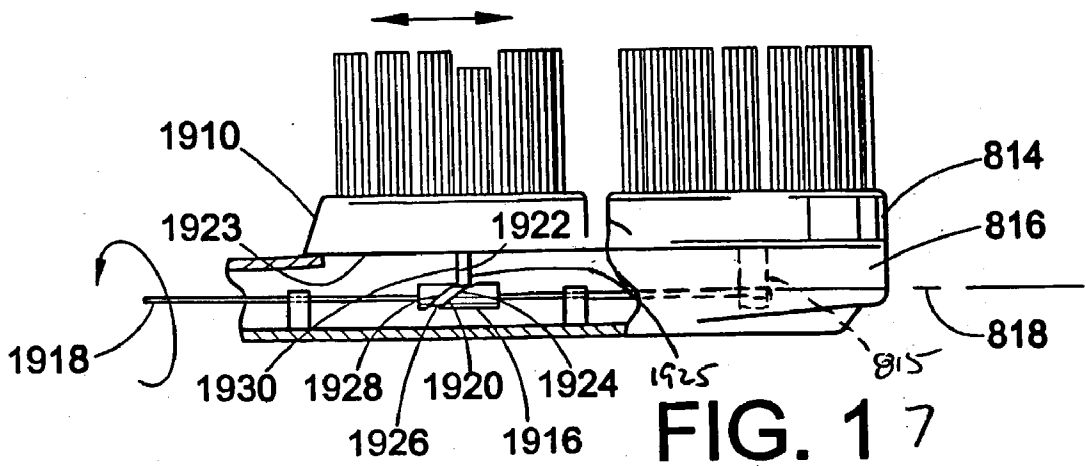

FIG. 18

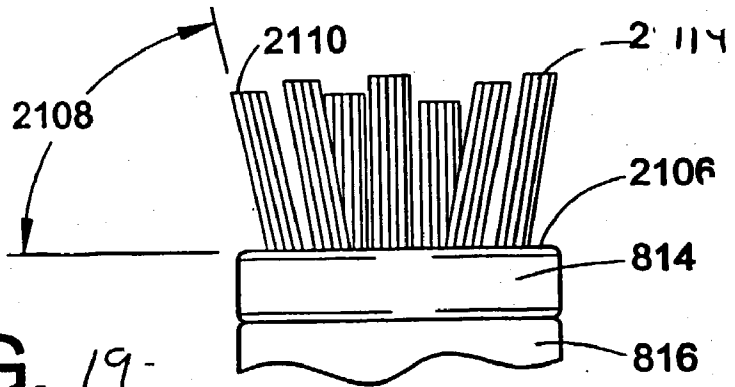

FIG. 19

## ELECTRIC TOOTHBRUSHES

[0001] This application claims the benefit of U.S. Provisional Application No. 60/361,625, filed Mar. 4, 2002.

### FIELD OF THE INVENTION

[0002] The invention relates to the field of electric toothbrushes and, more particularly, the invention relates to the field of electrically powered toothbrushes having at least one bristle holder that translates or translates.

### BACKGROUND OF THE INVENTION

[0003] The art is replete with techniques for transforming the rotational output of a motor or other electromotive power source into desired brushing motions. Many techniques include a shaft as a component of the drive train. The shaft may rotate, oscillate, or reciprocate. The shaft is coupled to a bristle holder. Most often, the bristle holder is driven by the shaft in a rotating or oscillating manner about an axis which is normal to the longitudinal axis of the shaft. However, there is a desire to provide bristle holders that provide a scrubbing action at the leading edge of the toothbrush head in combination with bristle holders having static bristles or other movable bristle holders.

### BRIEF SUMMARY OF THE INVENTION

[0004] An electric toothbrush is provided. The electric toothbrush includes a handle having an electric motor, a head, and a neck extending between the handle and the head. The head has first end disposed adjacent to the neck and a second end opposite the first end. The head has a first bristle holder with a plurality of bristles disposed therein and a second bristle holder having a plurality of bristles disposed therein. The first bristle holder is located at the second end of said head. A rotating shaft is operatively connected to the electric motor and to the first moving bristle holder to reciprocate the first moving bristle holder in a direction transverse to a longitudinal axis of the head.

### BRIEF DESCRIPTION OF THE DRAWINGS

[0005] It is believed that the present invention will be better understood from the following description taken in conjunction with the accompanying drawings in which:

[0006] **FIG. 1** is a top planar, partial sectional, top view of an electric toothbrush made in accordance with the present invention, wherein the electric toothbrush incorporates a rotating shaft;

[0007] **FIG. 2** is a planar, partial section top view of a toothbrush head suitable for use with the electric toothbrush of **FIG. 1**;

[0008] **FIG. 3** is a partial sectional side view of the embodiment of **FIG. 2**, taken along line 3-3 thereof;

[0009] **FIG. 4** is a planar, partial sectional top view of a second embodiment of a toothbrush head suitable for use with the electric toothbrush of **FIG. 1**;

[0010] **FIG. 5** is a partial sectional side view of the embodiment of **FIG. 4**, taken along line 5-5 thereof;

[0011] **FIG. 6** is a bottom view of an toothbrush having a second bristle holder. The toothbrush is shown in partial section;

[0012] **FIG. 7** is a sectional view taken along line A-A in **FIG. 6** of a first embodiment of a toothbrush head;

[0013] **FIG. 7A** is a partial sectional side view of the head of **FIG. 7**, taken along line B-B of **FIG. 6**;

[0014] **FIG. 8** is a sectional view taken along A-A in **FIG. 6** of a second embodiment of a toothbrush head;

[0015] **FIG. 9** is a sectional view taken along A-A in **FIG. 6** of a third embodiment of a toothbrush head;

[0016] **FIG. 10** is a partial sectional view taken along B-B in **FIG. 6** of a fourth embodiment of a toothbrush head;

[0017] **FIG. 11** is a partial sectional view taken along B-B in **FIG. 6** of a fifth embodiment a toothbrush head;

[0018] **FIG. 12** is a partial sectional view of the fifth embodiment of **FIG. 11**. The shaft is shown rotated to a different position than shown in **FIG. 12**;

[0019] **FIG. 13** is a partial sectional view taken along B-B in **FIG. 6** of a sixth embodiment of a toothbrush head;

[0020] **FIG. 14** is a partial sectional view taken along B-B in **FIG. 6** of a seventh embodiment of a toothbrush head;

[0021] **FIG. 15** is a bottom view of a head portion of a eighth embodiment of a toothbrush head;

[0022] **FIG. 16** is a partial sectional view of the eighth embodiment of a toothbrush head of **FIG. 15**;

[0023] **FIG. 17** is a partial sectional view taken along B-B in **FIG. 6** of a ninth embodiment of a toothbrush head;

[0024] **FIG. 18** is a side view of a toothbrush showing a first exemplary alternate bristle arrangement; and

[0025] **FIG. 19** is an end view taken along D-D of **FIG. 8** showing a second exemplary bristle arrangement.

### DETAILED DESCRIPTION OF THE INVENTION

[0026] All patents and patent applications referenced herein are expressly incorporated herein by reference, including U.S. provisional application No. 60/361,625, filed Mar. 4, 2002. Reference will now be made in detail to various embodiments of the present invention, examples of which are illustrated in the accompanying drawings wherein like numerals indicate the same elements throughout the views. As will be appreciated, the present invention is directed to electric toothbrushes and electric toothbrush heads having one or more moving bristle holders. Optionally, the head might also include static bristles. The present invention can also be used with electric toothbrushes having replaceable heads. One such suitable replaceable head arrangement is disclosed in U.S. Pat. No. 5,617,601. The present invention can be used in combination with electric toothbrushes that have shafts that translate, oscillate, or reciprocate (as well as combinations thereof) to directly impart motion to each moving bristle holder. Preferably, however, the present invention is used with a shaft that rotates. Alternatively, the movable bristle holders can also be interconnected amongst themselves so that the movement of one imparts movement to another.

[0027] Referring to **FIG. 1**, an electric toothbrush having a first bristle holder that translates or reciprocates while the second bristle holder is static relative to the head is illus-

trated. In other words, the shaft is not operatively connected to the second bristle holder to impart movement thereto. As used herein, the term “reciprocate” is intended to refer to a bidirectional linear motion (e.g., a back and forth motion or side to side motion). Vibration is any periodic movement having repeated cycles. Vibratory motion can have one or more frequencies and amplitudes. Vibratory motion that is substantially linear is a reciprocating motion. The electric toothbrush 10 comprises a toothbrush head portion 20, a body or handle 22, and an elongated neck 24 there between. As used herein, the term “forward” is intended to refer to the direction from the handle to the head while the term “rearward” is intended to refer to the direction from the head to the handle. In addition, the term “longitudinal” is intended to refer to a lengthwise feature of an element as seen from a top planar view thereof. For example, a longitudinal axis 30 is an axis passing through the longest dimension of an element, such as the head or a shaft. A longitudinal direction is a direction that generally corresponds to a longitudinal axis but which may not lie in the same plane as the longitudinal axis. For example, the longitudinal axes of a shaft and a toothbrush head may not lie in the same plane but generally extend in the same direction from a top planar view. Similarly, a neck and head that are angled with respect to each other may not have longitudinal axes that lie in the same plane, but do have axes that extend in the same general longitudinal direction from a top planar view. The electric toothbrushes of the present invention typically have an elongate head with a longitudinal axis passing through the longest dimension thereof. This axis typically extends in the same general direction as the longitudinal axes of the toothbrush neck and/or shaft. By the phrase “same general direction”, some angular deviation is contemplated between the axes.

[0028] The handle is hollow and includes a motor 26 and batteries 28 for powering the motor. The motor 26 is operatively connected to the shaft 34 either by a coupling 31 or by a gearing assembly (not shown). A rechargeable power source can be substituted for the batteries 28. The head 20 has a longitudinal axis 30 passing there through. The longitudinal axis 30 extends in the same general longitudinal direction as a longitudinal axis 32 of shaft 34. The shaft 34 is housed at least partially within neck 24. A first bristle holder 36 is disposed at a first end of the head 20, wherein the first end is at the forward most point of the head 20. While the first bristle holder 36 is illustrated as circular in shape, other shapes and sizes can be utilized. Further, while the first bristle holder 36 is disposed at the first end of the head 20, it will be appreciated that it can be disposed away from the first end and other features, such as stationary or static bristles, might be disposed between the first bristle holder 36 and the first end of the head 20.

[0029] A second bristle holder 38 is disposed adjacent the first bristle holder 36. The second bristle holder 38 is static or stationary relative to the neck 24 and handle 22 or is movable as described more fully hereafter. Referring to FIGS. 2 and 3, the first bristle holder 36 is movably mounted in slots 62 in the toothbrush head 64 and driven in a reciprocating or translating, transverse motion within the slots 62 by a cam 16 included on a driving shaft 68. Alternatively, the slots 36 could be disposed in the first bristle holder 36 rather than the housing of the toothbrush head 64. The slots 36 guide the first bristle holder 36 in its reciprocating movement. A plurality of L-shaped fingers 65

depend from a bottom surface 67 of the first bristle holder 36 and are at least partially, slideably disposed within the slots 62. While the fingers 65 are shown as L-shaped in cross-sectional end view of FIG. 3, it is recognized that the fingers 65 can be provided in other shapes and sizes. For example, the fingers 65 might be cylindrically shaped or provided as a parallelogram.

[0030] The cam 16 can comprise an appropriately shaped bead placed over or molded and fixedly secured to the shaft 34. For example, the bead is shaped as an eccentric cam. Alternatively, the cam can include one or more rectilinear, curvilinear or other kind of bend, as shown by way of example in the embodiment of FIG. 7A. First 70 and second 72 cam followers also depend from the bottom surface 67 of the first bristle holder 36. The cam followers are, for example, offset from the longitudinal axis 30 of the first bristle holder 36 (i.e., are not symmetrically disposed about the longitudinal axis 30 of the first bristle holder) and straddle or capture the cam 66. While the cam followers 70 and 72 are preferably offset from the longitudinal axis of the first bristle holder 36, the cam followers 70 and 72 are preferably disposed at about the middle of the first bristle holder 36. In other words, the cam followers are disposed about mid-way between the forward-most end of the first bristle holder 36 and the rearward-most end of the first bristle holder 36, although depending upon the location of the slots 36, the location of the cam followers might vary from about the middle of the first bristle holder 36. As the motor 26 rotates the shaft 34 in accordance with arrow C, the cam 66 comes into contact with a surface 74 of the first cam follower 70 and drives the first cam follower 70, and therefore, the first bristle holder 36 away from a first side 80 of the head portion 20 along a transverse axis 82 of the first bristle holder 36. As the shaft 34 continues to rotate, the cam 66 becomes disengaged with the first cam follower 70. The cam 66 then comes into contact with a surface 76 of the second cam follower 72 and drives the second cam follower 72, and therefore, the first bristle holder 36 toward the second side 84 of the head portion 20. A clearance 86 is provided between the first and second bristle holders 36,38 to accommodate the spacing requirements of this motion. As this back and forth or side to side motion is repeated (as the shaft 34 continues to rotate), a sweeping motion is provided that provides enhanced cleaning action to the teeth in the direction of arrow B in FIG. 3.

[0031] Referring to FIG. 4 and FIG. 5, in a second embodiment of the electric toothbrush, the second bristle holder 138 is movably mounted in slots 102 in the toothbrush head 20 and separately driven in a reciprocating or translating, transverse motion within the slots 102 by a cam 116 included on a driving shaft 108, in a similar manner to the cam 16 shown in FIGS. 2 and 3. The first bristle holder 136 is stationary. The cam 116 can comprise an appropriately shaped bead placed over or molded and fixedly secured to the shaft 108 as in the first embodiment. First 110 and second 112 cam followers depend from a bottom surface of the first bristle holder 138. The cam followers are, for example, offset from the longitudinal axis 30 of the second bristle holder and straddle or capture the cam 116. As the motor 26 (see FIG. 1) rotates the shaft 108, the cam 116 comes into contact with a surface 114 of the first cam follower 110 and drives the first cam follower 110, and therefore, the second bristle holder 138 away from a first side 120 of the brush portion 20 along a transverse axis 118

of the head. As the shaft **108** continues to rotate, the cam **116** becomes disengaged with the first cam follower **110**. The cam **116** then comes into contact with a surface **117** of the second cam follower **112** and drives the second cam follower **112**, and therefore, the second bristle holder **138** toward the second side **126** of the head. As this back and forth or side to side motion is repeated (as the shaft **108** continues to rotate), the desired sweeping motion is provided.

[0032] Referring to FIGS. 6 to 17, various embodiments incorporating a second movable bristle holder will now be described in combination with a first movable bristle holder similar to the first bristle holder **36** previously described with respect to FIGS. 3 and 4. A first bristle holder **814** of the head **816** has a pair of cam followers **815** (see, e.g., FIG. 7A) that depend from a bottom surface of the first bristle holder and that operatively engage the shaft **820** to reciprocate the first bristle holder **814** in a side to side motion substantially transverse to the longitudinal axis **818** of the head **816**, as previously discussed. The electric toothbrush **810** has a head **816** and a body or handle **817**. The electric toothbrush **810** includes a motor **819** and batteries for powering the motor. The head portion **816** has a longitudinal axis **818**. The first bristle holder **814** is illustrated as circular. However, other shape bristle holders are contemplated and within the scope of the invention. The motor **819** is operative to rotate the shaft **820**. In short, with regard to the construction and operation of the shaft **820** in relation to the first bristle holder **814**, the electric toothbrush **810** is similar to the toothbrush described in reference to FIGS. 1 to 3. However, the electric toothbrush **810** also has a second bristle holder disposed adjacent the first bristle holder, such as second bristle holder **822**. While it is desirable to locate the second bristle holder directly adjacent the first bristle holder, it is contemplated that a gap may be provided between the first and second bristle holders. In addition, the space between the first and second bristle holders might be filled with static, stationary or fixed bristles that are embedded in fixed or stationary third bristle holder (not shown) which forms part of the toothbrush head. In electric toothbrush **810**, the second bristle holder is movable and separately associated with, and separately driven by, the drive shaft **820**.

[0033] For example, referring to FIG. 7, a second bristle holder **910** is movably mounted in slots **912** in the toothbrush head **816** and separately driven in a vibratory, side-to-side, motion in a direction substantially transverse to the direction of the longitudinal axis **818** by an eccentric cam **914** included on a driving shaft **918**. The cam **914** and other cams described below can comprise one or more bends in the shaft **918**, as shown for example in FIG. 7A, and as seen in views of other embodiments described below in FIG. 11, FIG. 12, and FIG. 13. Alternatively, the cam **914** can be provided as a separate piece, which is attached to the shaft **918** by adhesive, a press or snap fit, a co-molding or any other mechanical or chemical means known in the art. Optionally, the driving shaft is supported by a shaft support **920**. A cam follower **922** depends from a bottom surface **924** of the second bristle holder **910**. The cam follower **922** is offset from a longitudinal axis **926** of the second bristle holder. As the motor **819** of the toothbrush **810** rotates the shaft **918**, the cam **914** comes into contact with a cam contact surface **928** of the cam follower **922** and drives the cam follower **922**, and therefore, the second bristle **910**

holder toward one side **930** of the toothbrush **810** and away from the longitudinal axis **818** of the head portion **816**. As the shaft **918** continues to rotate, the cam **914** becomes disengaged with the cam follower **922**. A resilient biasing member such as a spring **934**, lodged between a wall of the head portion **816** and a second surface of the cam follower, urges the cam follower **922**, and therefore the second bristle holder **910**, back toward the longitudinal axis **818** of the head portion **816**. As this back and forth or sided to side motion is repeated (as the shaft **918** continues to rotate), a sweeping or brushing motion is provided that is distinct from and complimentary to the motion provided by the first bristle holder **814**. The stroke and/or frequency of the second bristle holder **910** can be changed by varying the construction of the spring and placement and/or sizing of the cam **914** and the cam follower **922**. For example, the cam follower **922** might be placed closer to the axis **926** to provide a shorter stroke or the cam follower **922** or a stronger spring might be provided to increase the rate of return of the second bristle holder **910** or more than one spring might be provided. Alternatively, the cam follower **922** might form an acute angle with the bottom surface **924** of the second bristle holder **910** or the first surface can be provided as accurate, curvilinear, or in other complex forms as opposed to the planar surface shown in FIG. 7.

[0034] Referring to FIG. 8, in a second embodiment of the electric toothbrush **810**, a second bristle holder **1010** is movably mounted in slots **1012** in the toothbrush head **816** and separately driven in a vibratory, swinging or pivoting motion about a hinge or pivot **1014**, by a cam **1016** included on a driving shaft **1018**. The cam **1016** can comprise one or more bends in the shaft **1018** or be provided as a separate piece as previously discussed. Optionally, the driving shaft is supported by a shaft support **1020**. A cam contact surface **1022** is located on a bottom surface of the second bristle holder **1010**. As the motor **819** of the toothbrush **810** rotates the shaft **1018**, the cam **1016** comes into contact with the cam contact surface **1022** and drives or pushes the second bristle holder **1010** causing the second bristle holder to swing or pivot about the hinge or pivot **1014**. As the shaft **1018** continues to rotate, the cam **1016** becomes disengaged with the cam contact surface **1022**. During use, as the cam **1016** comes in contact with the cam contact surface **1022**, bristles of the second bristle holder **1010** are urged against the users teeth with greater force. Preferably, bristles of the second bristle holder **1010** are urged between the teeth of the user to provide a cleaning and flossing function. As the cam disengages with the contact surface **1022**, bristles pressing against the teeth of the user urge the second bristle holder away from the users teeth. As this swinging or pivoting motion is repeated (as the shaft **1018** continues to rotate), a flossing or deep cleaning motion is provided that is distinct from and complimentary to the motion provided by the first bristle holder **814**.

[0035] Referring to FIG. 9, in a third embodiment, a second bristle holder **1110** is movably mounted in slots **1112** in the toothbrush head **816** and separately driven in a vibratory, lifting or vertical pulsating motion (e.g., in a direction substantially perpendicular to the longitudinal axis **1114** and substantially parallel to a surface **1115** of the second bristle holder **1110** as shown by way of example in FIG. 9) within the slots **1112**, by a cam **1116** included on a driving shaft **1118**. Optionally, the driving shaft is supported by a shaft support **1120**. The cam **1116** can comprise one or

more bends in the shaft **1118** or can be provided as a separate piece as previously discussed. A cam contact surface **1122** is located on a bottom surface of the second bristle holder **1110**. As the motor **819** (see FIG. 6) of the toothbrush **810** rotates the shaft **1118**, the cam **1116** comes into contact with the cam contact surface **1122** and drives or lifts in a vibratory, lifting, or vertical pulsating motion the second bristle holder **1110** causing the second bristle holder to lift or pulsate in a direction away from the head portion **816** and toward the teeth of a toothbrush user (not shown). As the shaft **1118** continues to rotate, the cam **1116** becomes disengaged with the cam contact surface **1122**. During use, as the cam **1016** comes in contact with the cam contact surface **1122**, bristles of the second bristle holder **1110** are urged against the users teeth with varying degrees of force. Preferably, bristles of the second bristle holder **1110** are urged between the teeth of the user to provide a cleaning and flossing function. As the cam disengages with the contact surface **1122**, bristles pressing against the teeth of the user urge the second bristle holder away from the users teeth and back toward the head portion **816**. As this lifting or vertical pulsating motion is repeated (as the shaft **1018** continues to rotate), a flossing or deep cleaning motion is provided that is distinct from and complimentary to the motion provided by the first bristle holder **814**.

[0036] Referring to FIG. 10, in a fourth embodiment, a second bristle holder **1210** is movably mounted in slots (not shown, but similar to the slots **912** illustrated in FIG. 7) in the toothbrush head **816** and separately driven in a reciprocating or translating, longitudinal motion within the slots by a cam **1216** included on a driving shaft **1218**. Optionally, the shaft is supported by shaft supports **1217**. The shaft supports may include C or U shaped portions (not shown) that are operative to receive and snap around the shaft. Other means for retaining a shaft in a support are known in the art. The cam **1216** can comprise a shaped bead, with an appropriate eccentric configuration, placed or molded over and firmly secured to the shaft **1218**. In one embodiment, the cam **1216** includes a pair of acutely angled surfaces **1219**, **1220** which are inclined in the same direction and at the same angle of inclination, but which are disposed at opposite ends of the cam **1216**. The direction of inclination and angle of inclination can be varied as desired to change the frequency and stroke of the second bristle holder **1210**. First **1222** and second **1226** cam followers depend from a bottom surface of the second bristle holder **1210**. The cam followers **1222**, **1226** are offset or spaced from a transverse axis **1230** of the second bristle holder. The cam followers **1222**, **1226** straddle and/or capture the cam **1216** so that the angled surfaces **1219**, **1220** slidably engage the free ends of the cam followers **1222** and **1226**. As the motor **819** (see FIG. 6) of the toothbrush **810** rotates the shaft **1218**, the first acutely angled surface **1220** of the cam **1216** comes into contact with a surface of the first cam follower **1222** and drives the cam follower, and therefore, the second bristle holder **1210**, away from the first bristle holder **814** along the longitudinal axis **818** of the head portion **816**. As the shaft **918** continues to rotate, the cam **1216** becomes disengaged with the first cam follower **1222**. The second acutely angled second surface **1219** of the cam **1216** then comes into contact with a surface of the second cam follower **1226** and drives the second cam follower **1226**, and therefore, the second bristle holder **1210**, back toward the first bristle holder **814**. As this back and forth motion is repeated (as the shaft **918** continues

to rotate), a scrubbing action is provided by the reciprocating or translating motion that is distinct from and complimentary to the motion provided by the first bristle holder **814**.

[0037] Referring to FIG. 11 and FIG. 12, in a fifth embodiment of the electric toothbrush **810**, a second bristle holder **1310** is movably mounted in slots (not shown, but similar to the slots **912** illustrated in FIG. 7) in the toothbrush head **816** and separately driven in an reciprocating or translating, longitudinal motion, by a cam **1316** included on a driving shaft **1318**. Optionally, the shaft is supported by shaft supports **1317**. The shaft supports may include C or U shaped portions (not shown) that are operative to receive and snap around the shaft. Other means for retaining a shaft in a support are known in the art. The cam **1316** is sinusoidal or curvilinear in nature in that it has one or more adjacent arcuate bends **1319** and **1320** in the shaft **1318**. The arcuate bends **1319**, **1320** each have an apex **1321**, and the apexes **1321** are disposed on opposite sides of the driving shaft **1318**. A cam follower **1322** depends from a bottom surface **1323** of the second bristle holder **1310** and is disposed between the apexes **1321** of the cam **1316**. As the motor **819** of the toothbrush **810** rotates the shaft **1318**, a first surface **1325** of the cam **1316** comes into contact with a first surface **1324** of the cam follower **1322** and drives the cam follower **1322**, and therefore, the second bristle holder **1310** away from the first bristle holder **814** in a direction along the longitudinal axis **818** of the head portion **816**. As the shaft **1318** continues to rotate, the first surface **1325** of the cam **1316** reaches the apex **1321** and becomes disengaged with the first cam follower surface **1324**. A second surface **1326** of the cam **1316** then comes into contact with a second surface **1426** of the cam follower **1322** and drives the cam follower **1322**, and therefore, the second bristle holder **1310** back toward the first bristle holder **814**. As this back and forth motion is repeated (as the shaft **1318** continues to rotate), a scrubbing action is provided by the reciprocating or translating motion that is distinct from and complimentary to the motion provided by the first bristle holder **814**. The stroke and frequency of the reciprocating or translating motion can be varied by changing the spacing between the apexes and/or the amplitude or height of the apexes.

[0038] Referring to FIG. 13, in a sixth embodiment of the electric toothbrush **810**, a second bristle holder **1508** is movably mounted to the toothbrush head **816** with a pivot **1510**, which can be provided in the form of a pin or hinge, is installed at a centrally located transverse axis of the second bristle holder **1508**. In one embodiment, the second bristle holder **1508** pivots about a pin, which is anchored in the sidewalls of the toothbrush neck or head **816** at the midpoint of the second bristle holder **1508**. The second bristle holder **1508** is separately driven in a vibratory, swinging, teetering or rocking motion by a cam comprised of first **1512** and second **1514** cam portions included on a driving shaft **1518**. Optionally, the shaft is supported by shaft supports **1519**. The shaft supports may include C or U shaped portions (not shown) that are operative to receive and snap around the shaft. Other means for retaining a shaft in a support are known in the art. The cam portions **1512**, **1514** can comprise one or more rectilinear, curvilinear or other bends in the shaft **1518**. As is illustrated in FIG. 13 the first cam portion **1512** is located adjacent a first side of the pivot and the second cam portion **1514** is located adjacent a second side of the pivot. The second cam portion **1514** can comprise a portion of the remote-most end of the shaft **1518**.

First 1520 and second 1522 cam contact surfaces are located on a bottom surface of the second bristle holder 1508. As is the case with all the described embodiments, the amplitude or height of the bends or eccentricities that make up the first and second cam portions 1512, 1514 are large enough reach the related cam contact surface(s) and to drive the second bristle holder a desired distance toward, into, across or along a toothbrush users teeth. As the motor 819 of the toothbrush 810 rotates the shaft 1518, the first cam portion 1512 comes into contact with the first cam contact surface 1520 and drives or lifts (relative to the figure) a first end 1522 of the second bristle holder 1510 causing the first end 1522 to rock or move about the pivot 1510 in a direction away from the head portion 816 and toward the teeth of a toothbrush user (not shown). This action lowers a second end 1526 of the second bristle holder 1508 causing the second end 1522 to rock or move about the pivot 1510 in a direction away from the head portion 816 and toward the teeth of the toothbrush user. This action lowers a first end 1530 of the second bristle holder back toward the head portion 816. During use, as the first and second cam portions 1512, 1514 alternately come in contact with the first and second cam contact surfaces 1520, 1522, bristles of the second bristle holder 1508 are urged against teeth of the user with varying degrees of force. Preferably, bristles of the second bristle holder 1508 are urged between the teeth of the user to provide a cleaning and flossing function. As the rocking or pivoting motion is repeated (as the shaft 1518 continues to rotate), a flossing or deep cleaning motion is provided that is distinct from and complimentary to the motion provided by the first bristle holder 814.

[0039] Referring to FIG. 14, in a seventh embodiment of the electric toothbrush 810, a second bristle holder 1608 is movably mounted to the toothbrush head 816 with a pivot 1610, which can be provided in the form of a pin or of a hinge installed at a transverse axis of the second bristle holder 1608. In one embodiment, the second bristle holder 1608 pivots about a pin, which is anchored in the side walls of the toothbrush neck at one end of the second bristle holder 1608. The transverse axis is, for example, adjacent to a first end 1612 of the second bristle holder 1608. The second bristle holder 1608 is separately driven in a vibratory, swinging, pivoting or rocking motion by a cam 1614 included on a driving shaft 1618. Optionally, the shaft is supported by shaft supports 1619. The shaft supports may include C or U shaped portions (not shown) that are operative to receive and snap around the shaft. Other means for retaining a shaft in a support are known in the art. The cam 1614 can comprise one or more bends in the shaft 1618. For example, the bends can be rectilinear, curvilinear or other kinds of bends. A cam contact surface 1622 is located on a bottom surface of the second bristle holder 1608 adjacent to a second end 1626 thereof. As the motor 819 of the toothbrush 810 rotates the shaft 1618, the cam 1614 comes into contact with the cam contact surface 1622 and drives or lifts (relative to the figure) the second end 1626 of the second bristle holder 1608 causing the second end 1626 of the second bristle holder 1608 to rock or move about the pivot

1610 in a direction away from the head portion 816 and toward the teeth of a toothbrush user (not shown). As the shaft 1618 continues to rotate, the cam 1614 becomes disengaged with the cam contact surface 1622. During use, as the cam 1614 comes in contact with the cam contact surface 1622, bristles of the second bristle holder 1608 are urged against teeth of the user with a varying degree of force. Preferably, bristles of the second bristle holder 1608 are urged between the teeth of the user to provide a cleaning and flossing function. As the cam disengages with the contact surface 1622, bristles pressing against the teeth of the user urge the second bristle holder away from the users teeth and back toward the head portion 816. As this swinging or pivoting motion is repeated (as the shaft 1618 continues to rotate), a flossing or deep cleaning motion is provided that is distinct from, and complimentary to, the motion provided by the first bristle holder 814.

[0040] Referring to FIG. 15 and FIG. 16, in an eighth embodiment of the electric toothbrush 810, a second bristle holder 1810 is movably mounted in slots 1812 in the toothbrush head 816 and separately driven in a reciprocating or translating, transverse motion within the slots 1812 by a cam 1816 included on a driving shaft 1818. This motion is the same type of motion previously described with respect to the second bristle holder 910 shown in FIG. 7 and is also the same type of motion that the first bristle holder 814 undergoes. The cam 1816 can comprise an appropriately shaped bead placed over or molded and fixedly secured to the shaft 1818. The transverse motion of the second bristle holder 1810 can be out of phase with the transverse movement of the first bristle holder 814. For example, as the first bristle holder 814 travels toward one side of the head 816, the second bristle holder 1810 would be traveling toward the opposite side of the head 816. The cam can include one or more rectilinear, curvilinear or other kind of bend. First 1822 and second 1826 cam followers depend from a bottom surface of the second bristle holder 1810. The cam followers are, for example, offset from the longitudinal axis 818 of the second bristle holder and straddle or capture the cam 1816. As the motor 819 (see FIG. 6) rotates the shaft 1818, the cam 1816 comes into contact with a surface 1821 of the first cam follower 1822 and drives the first cam follower 1822, and therefore, the second bristle holder 1810 away from a first side 1828 of the head portion 816 along an axis 1830 transverse to the longitudinal axis 818 of the head portion 816. As the shaft 1818 continues to rotate, the cam 1816 becomes disengaged with the first cam follower 1822. The cam 1816 then comes into contact with a surface 1825 of the second cam follower 1826 and drives the second cam follower 1826, and therefore, the second bristle holder 1810 back toward the first side 1828 of the head portion 816. As this back and forth or side to side motion is repeated (as the shaft 1818 continues to rotate), a sweeping motion is provided that is distinct from and complimentary to the motion provided by the first bristle holder 814.

[0041] Referring to FIG. 17, in a ninth embodiment of the electric toothbrush 810, a second bristle holder 1910 is movably mounted in slots (not shown) in the toothbrush head 816 and separately driven in a reciprocating or translating, longitudinal motion, by a cam 1916 included on a driving shaft 1918. The cam 1916 can comprise a shaped bead, with an appropriate configuration, placed or molded over and firmly secured to the shaft 1918. The cam 1916 includes a reversing spiral or helical groove 1920. The spiral

or helical groove extends around a circumference of the bead and spirals about a longitudinal axis of the bead. For example, the longitudinal axis coincides with the shaft **1918**. A cam follower **1922** depends from a bottom surface **1923** of the second bristle holder **1910**. The cam follower **1922** is slidingly received within the spiral groove **1920**. As the motor **819** of the toothbrush **810** rotates the shaft **1918**, a first surface **1924** of the spiral groove **1920** comes into contact with a first surface **1925** of the cam follower **1922** and drives the cam follower **1922**, and therefore, the second bristle holder **1910** away from the first bristle holder **814** along the longitudinal axis **818** of the head portion **816**. As the shaft **1918** continues to rotate, the cam follower **1922** reaches an apex **1926** of the spiral groove **1920** and the first surface **1924** of the spiral groove **1920** becomes disengaged with the first cam surface **1925**. A second surface **1928** of the spiral groove **1920** then comes into contact with a second surface **1930** of the cam follower **1922** and drives the cam follower **1922**, and therefore, the second bristle holder **1910** back toward the first bristle holder **814**. As this back and forth motion is repeated (as the shaft **1918** continues to rotate), a scrubbing motion is provided that is distinct from and complimentary to the motion provided by the first bristle holder **814**. Optionally cam **1916** is eccentrically mounted on the shaft **1918** and the longitudinal axis of the bead or cam **1916** does not coincide with the shaft **1918**. In this case, if the cam follower **1922** is made long enough to ride on the bottom of the spiral groove **1920**, a lifting or vertical pulsing force is provided to the second bristle holder as the eccentrically mounted came is rotated by the shaft. Alternately, or additionally, the depth of the groove is varied. The variation in depth provides lifting or vertical pulsing forces to the cam follower and therefore to the second bristle holder. The spiral groove may be replaced with a groove that cycles back and forth along the longitudinal axis of the bead several times as it circles the bead. This sort of groove can be used to increase the reciprocating frequency of the second bristle holder.

[**0042**] While the above-described embodiments of the present invention have been illustrated for simplicity with bristles which extend in a direction substantially perpendicular to the longitudinal axis **818** and the surface (for example see **1115** of **FIG. 9**) of the bristle holders, it is contemplated that the bristles might be arranged differently to complement or further enhance the motions of the first and/or second bristle holders. Referring to **FIG. 18**, some or all of the bristles might extend in a direction which forms an acute angle **2008** to a surface **2006** of the bristle holder and extends in a direction toward or away from the handle, such as shown by way of example in **FIG. 18** with respect to bristles **2010** and **2014** respectively. Referring to **FIG. 19**, in another embodiment, some of the bristles might extend outwardly away from head, in another direction, again forming an acute angle **2108** with respect to the surface of the bristle holder, as shown by way in **FIG. 19** with respect to bristles **2110** and **2114**. Elastomeric bristles or bristles of varying height might also be used, such as described in U.S. Pat. Nos. Des. 330,286 and Des. 434,563. Other preferred bristle arrangements suitable for use include those arrangements described in whole or part in U.S. Pat. Nos. 6,006,394; 4,081,876; 5,046,213; 5,335,389; 5,392,483; 5,446,940; 4,894,880; and international publication no. WO 99/23910.

[**0043**] The invention has been described with reference to particular embodiments. Modifications and alterations will occur to others upon reading and understanding this specification. For example, while the second bristle holders of the embodiments illustrated in **FIGS. 6** to **17** have been described as driven directly by the shaft, it is contemplated that second bristle holder could be directly driven by the first bristle holder by a link, pin, gearing, rack and pinion, or other mechanical connection between the first bristle holder and the second bristle holder. Further, while the first bristle holder has been illustrated as cylindrical in shape, the first bristle holder can encompass alternative shapes and sizes. It is intended that these and other modifications and alterations are included insofar as they come within the scope of the appended claims or equivalents thereof.

What is claimed is:

1. An electric toothbrush, comprising:

a handle having an electric motor;

a head;

a neck extending between said handle and said head, said head having a first end disposed adjacent to said neck and a second end opposite said first end, said head having a first bristle holder with a plurality of bristles disposed therein and a second bristle holder having a plurality of bristles disposed therein, wherein said first moving bristle holder is located at said second end of said head; and

a rotating shaft operatively connected to said electric motor and to said first moving bristle holder to reciprocate said first moving bristle holder in a direction transverse to a longitudinal axis of said head.

2. The electric toothbrush of claim 1, wherein said bristles of said second bristle holder are static.

3. The electric toothbrush of claim 1, wherein said first bristle holder has a plurality of cam followers that depend from said first bristle holder and operatively engage a cam on said rotating shaft.

4. The electric toothbrush of claim 1, wherein said second bristle holder is located at said first end of said head.

5. The electric toothbrush of claim 1, wherein said cam followers are offset from a longitudinal axis of said first bristle holder.

6. The electric toothbrush of claim 1, said head further comprising a plurality of slots for guiding said first bristle holder.

7. The electric toothbrush of claim 6, wherein said slots are formed in said first bristle holder.

8. The electric toothbrush of claim 5, wherein said cam followers are disposed near the middle of said first bristle holder.

9. The electric toothbrush of claim 6, said head further comprises a plurality of fingers that engage said plurality of slots.

10. The electric toothbrush of claim 9, wherein said fingers depend from said first bristle holder.

11. The electric toothbrush of claim 1, wherein said second bristle holder is movable.

12. The electric toothbrush of claim 11, wherein said movement is selected from the group consisting of reciprocation, pivoting, and vertical pulsating motion.

13. The electric toothbrush of claim 11, wherein said rotating shaft engages said second bristle holder.

- 14.** An electric toothbrush, comprising:
- a handle having an electric motor;
  - a head;
  - a neck extending between said handle and said head, said head having a first end disposed adjacent to said neck and a second end opposite said first end, said head having a first bristle holder with a plurality of bristles disposed therein and a second bristle holder having a plurality of bristles disposed therein, wherein said first moving bristle holder is located at said second end of said head; and
  - a rotating shaft operatively connected to said electric motor and to said first moving bristle holder to reciprocate said first moving bristle holder in a direction transverse to a longitudinal axis of said head, said head further comprising a plurality of slots for guiding said first bristle holder.
- 15.** The electric toothbrush of claim 14, wherein said bristles of said second bristle holder are static.

**16.** The electric toothbrush of claim 14, wherein said first bristle holder has a plurality of cam followers that depend from said first bristle holder and operatively engage a cam on said rotating shaft.

**17.** The electric toothbrush of claim 14, wherein said cam followers are offset from a longitudinal axis of said first bristle holder.

**18.** The electric toothbrush of claim 17, wherein said cam followers are disposed near the middle of said first bristle holder.

**19.** The electric toothbrush of claim 14, wherein said slots are formed in said first bristle holder.

**20.** The electric toothbrush of claim 14, wherein said head further comprises a plurality of fingers that engage said plurality of slots.

**21.** The electric toothbrush of claim 14, wherein said second bristle holder is movable.

**22.** The electric toothbrush of claim 21, wherein said rotating shaft engages said second bristle holder.

\* \* \* \* \*