

(12) INTERNATIONAL APPLICATION PUBLISHED UNDER THE PATENT COOPERATION TREATY (PCT)

(19) World Intellectual Property Organization
International Bureau



(43) International Publication Date
20 May 2010 (20.05.2010)

PCT

(10) International Publication Number
WO 2010/056696 A2

- (51) International Patent Classification:
B32B 27/08 (2006.01) *B32B 7/12* (2006.01)
- (21) International Application Number:
PCT/US2009/063963
- (22) International Filing Date:
11 November 2009 (11.11.2009)
- (25) Filing Language: English
- (26) Publication Language: English
- (30) Priority Data:
61/198,981 12 November 2008 (12.11.2008) US
- (71) Applicant (for all designated States except US):
GRAPHIC PACKAGING INTERNATIONAL, INC.
[US/US]; 814 Livingston Court, Marietta, GA 30067
(US).
- (72) Inventors; and
- (75) Inventors/Applicants (for US only): LAFFERTY, Terrence, P. [US/US]; 100 Klompen Ct., Neenah, WI 54956 (US). MIDDLETON, Scott, W. [US/US]; 3065 Pine Ridge Road, Oshkosh, WI 54904 (US).
- (74) Agents: STANO, Dana, E. et al.; Womble Carlyle Sandridge & Rice, PLLC, P.O. Box 7037, Atlanta, GA 30357-0037 (US).
- (81) Designated States (unless otherwise indicated, for every kind of national protection available): AE, AG, AL, AM, AO, AT, AU, AZ, BA, BB, BG, BH, BR, BW, BY, BZ,

CA, CH, CL, CN, CO, CR, CU, CZ, DE, DK, DM, DO, DZ, EC, EE, EG, ES, FI, GB, GD, GE, GH, GM, GT, HN, HR, HU, ID, IL, IN, IS, JP, KE, KG, KM, KN, KP, KR, KZ, LA, LC, LK, LR, LS, LT, LU, LY, MA, MD, ME, MG, MK, MN, MW, MX, MY, MZ, NA, NG, NI, NO, NZ, OM, PE, PG, PH, PL, PT, RO, RS, RU, SC, SD, SE, SG, SK, SL, SM, ST, SV, SY, TJ, TM, TN, TR, TT, TZ, UA, UG, US, UZ, VC, VN, ZA, ZM, ZW.

- (84) Designated States (unless otherwise indicated, for every kind of regional protection available): ARIPO (BW, GH, GM, KE, LS, MW, MZ, NA, SD, SL, SZ, TZ, UG, ZM, ZW), Eurasian (AM, AZ, BY, KG, KZ, MD, RU, TJ, TM), European (AT, BE, BG, CH, CY, CZ, DE, DK, EE, ES, FI, FR, GB, GR, HR, HU, IE, IS, IT, LT, LU, LV, MC, MK, MT, NL, NO, PL, PT, RO, SE, SI, SK, SM, TR), OAPI (BF, BJ, CF, CG, CI, CM, GA, GN, GQ, GW, ML, MR, NE, SN, TD, TG).

Declarations under Rule 4.17:

- as to applicant's entitlement to apply for and be granted a patent (Rule 4.17(ii))
- as to the applicant's entitlement to claim the priority of the earlier application (Rule 4.17(iii))

Published:

- without international search report and to be republished upon receipt of that report (Rule 48.2(g))



WO 2010/056696 A2

(54) Title: SUSCEPTOR STRUCTURE

(57) Abstract: A microwave energy interactive structure comprises a first susceptor film comprising a first layer of microwave energy interactive material supported on a first polymer film, a moisture-containing layer joined to the first layer of microwave energy interactive material, an adjoining layer joined to the moisture-containing layer such that the moisture-containing layer is disposed between the susceptor film and the adjoining layer, the adjoining layer being joined to the moisture-containing layer by a discontinuous adhesive layer, and a second layer of microwave energy interactive material on a side of the adjoining layer opposite the moisture-containing layer.

SUSCEPTOR STRUCTURE

CROSS-REFERENCE TO RELATED APPLICATION

This application claims the benefit of U.S. Provisional Application No. 5 61/198,981, filed November 12, 2008, which is incorporated by reference herein in its entirety.

BACKGROUND

Susceptors have been used in conventional microwave heating packages to 10 enhance the heating, browning, and/or crisping of food items. A susceptor generally comprises a thin layer of microwave energy interactive material (generally less than about 100 angstroms in thickness, for example, from about 60 to about 100 angstroms in thickness, and having an optical density of from about 0.15 to about 0.35, for example, about 0.21 to about 0.28) that tends to absorb at 15 least a portion of impinging microwave energy and convert it to thermal energy (i.e., heat) at the interface with the food item. Susceptors are typically supported on a microwave energy transparent substrate, for example, a polymer film, thereby collectively forming a "susceptor film". Susceptor films, in turn, are often joined to a dimensionally stable supporting material (or "support"), for example, paper or 20 paperboard ("moisture-containing supports" or "fiber-based supports"), to collectively define a "supported susceptor film".

Supported susceptor films may be used alone or in combination with numerous other materials to form various microwave heating constructs. However, when the exposed side of the moisture-containing support is joined to 25 another layer using a continuous layer of adhesive, the resulting structure may tend to delaminate during heating. While not wishing to be bound by theory, it is believed that during heating, the moisture in the moisture-containing support is released as water vapor, which exerts a pressure on the adjacent layers of the structure. With no path for the water vapor to escape, the layers of the structure 30 tend to delaminate and loft away from one another. In some cases, this lofting or

pillowing of the structure can cause the food item seated on the structure to be turned over or toppled undesirably. This phenomenon has been observed both when the supported susceptor film has been joined to another fiber-based layer and when the supported susceptor film has been joined to another polymer film layer.

5 It is known that structures with more than one susceptor may generate more heat than structures with a single susceptor. Thus, in such multi-susceptor structures, the risk of delamination may be amplified. Thus, there remains a need for a multi-susceptor structure that resists unintentional, uncontrolled delamination during use. There also remains a need for a method of making such a structure.

10

SUMMARY

This disclosure relates generally to various microwave energy interactive structures, various constructs formed from such structures, various methods of making and such structures and constructs, and various methods of using such structures and constructs to heat, brown, and/or crisp a food item in a microwave oven.

15 The structures generally comprise a supported susceptor film, which includes a susceptor layer disposed between a polymer film layer and a moisture-containing support layer (e.g., paper or paperboard), and an adjoining layer, for example, a polymer film, paper layer, or paperboard layer. The moisture-containing layer is joined to the adjoining layer using any suitable method that allows for the release of moisture from the moisture-containing layer without causing uncontrolled or undesirable lamination of the structure.

20 In one example, the moisture-containing support layer is joined to the adjoining layer using a discontinuous layer of adhesive. The discontinuous layer of adhesive may be applied in a pattern, a random configuration, or any other manner that results in the formation of passageways through the adhesive layer that allow the water vapor to be released from the structure.

25 By way of example, and not limitation, one exemplary structure according to the disclosure may include two supported susceptor films joined to one another

30

using a discontinuous layer of adhesive. The supported susceptor films may be joined with their respective moisture-containing layers facing one another, or with the moisture-containing layer of one supported susceptor film being joined to the polymer film of the other supported susceptor film.

5 Another exemplary structure according to the disclosure may include a supported susceptor film joined to a microwave energy interactive insulating material using a discontinuous layer of adhesive. The microwave energy interactive insulating material (“insulating material”) may be any suitable material that both alters the effect of microwave energy on an adjacent food item and that
10 provides some degree of thermal insulation from the microwave heating environment. For example, the insulating material may include one or more susceptor layers in combination with one or more expandable insulating cells.

The various structures may be used to form numerous constructs, packages, or apparatuses (collectively “constructs”) for heating, browning, and/or crisping a
15 food item in a microwave oven. Some of such constructs may include, but are not limited to, trays, platforms, sleeves, disks, cards, or pouches.

Other features, aspects, and embodiments of the invention will be apparent from the following description and accompanying figures.

20 BRIEF DESCRIPTION OF THE DRAWINGS

The description refers to the accompanying schematic drawings in which like reference characters refer to like parts throughout the several views, and in which:

FIG. 1A is a schematic cross-sectional view of an exemplary microwave
25 energy interactive structure;

FIGS. 1B-1E schematically depict exemplary patterns of adhesive that may be used to form the construct of **FIG. 1A**;

FIG. 2 is a schematic cross-sectional view of another exemplary microwave energy interactive structure;

FIG. 3 is a schematic cross-sectional view of still another exemplary microwave energy interactive structure;

FIG. 4A is a schematic cross-sectional view of yet another exemplary microwave energy interactive structure;

5 **FIG. 4B** is a schematic, partially cutaway, perspective view of a first side of a construct for heating, browning, and/or crisping a food item in a microwave oven, formed from the susceptor structure of **FIG. 4A**;

FIG. 4C is a schematic, partially cutaway, perspective view of a second side of a construct for heating, browning, and/or crisping a food item in a microwave oven, formed from the susceptor structure of **FIG. 4A**;

FIG. 4D is a schematic perspective view of a portion of the construct of **FIGS. 4B** and **4C**, after sufficient exposure to microwave energy;

FIG. 4E is a diagram of an exemplary process for forming the structure and construct of **FIGS. 4A-4D**;

15 **FIGS. 5-7** are schematic cross-sectional views of exemplary microwave energy interactive insulating materials that may be used in the construct of **FIGS. 4B** and **4C**;

FIG. 8A is a schematic top plan view of an exemplary microwave heating construct including a plurality of microwave energy transparent areas; and

20 **FIG. 8B** is a schematic cross-sectional view of a portion of the construct of **FIG. 8A**.

DESCRIPTION

Various aspects of the invention may be understood further by referring to the figures. For purposes of simplicity, like numerals may be used to describe like features. It will be understood that where a plurality of similar features are depicted, not all of such features necessarily are labeled on each figure. It also will be understood that the various components used to form the constructs may be interchanged. Thus, while only certain combinations are illustrated herein, numerous other combinations and configurations are contemplated hereby.

FIG. 1A schematically illustrates a cross-sectional view of a portion of susceptor structure **100**. The structure **100** includes a susceptor film **102**, namely, a layer of microwave energy interactive material **104** (e.g., a first layer of microwave energy interactive material) supported on a polymer film **106**. The susceptor film **102** is joined to a dimensionally stable, moisture-containing support layer **108** (e.g., a cellulose-based support such as paper or paperboard) using a substantially continuous layer of adhesive **110** to collectively define a supported susceptor film **112**. The supported susceptor film **112** is joined to an adjoining layer **114** using a discontinuous layer of adhesive **116**. Another layer of microwave energy interactive material **118** (e.g., a second layer of microwave energy interactive material) is disposed within the structure **100** on a side of the adjoining layer **114** opposite the first layer of microwave energy interactive material **104**. The second layer of microwave energy interactive material **118** may be joined to the adjoining layer **114** as shown, or in other embodiments, one or more layers may be disposed between the second layer of microwave energy interactive material **118** and the adjoining layer **114**. It is also contemplated that the structure **100** may include other layers, as will be discussed further below.

The discontinuous layer of adhesive **116** generally defines joined areas and unjoined areas between the moisture-containing layer **108** and the adjoining layer **114**. The unjoined areas may be at least partially interconnected to define one or more passageways **120** that are in open communication with the exposed or open (e.g., unglued) peripheral edges of the adjacent layers **108**, **114** of the structure (not shown in **FIG. 1A**, see, e.g., **FIGS. 4B** and **4C**). When the susceptor structure **100** is exposed to microwave energy, the layers of microwave energy interactive material **104**, **118** heat, thereby causing the moisture in the moisture-containing layer **108** to be converted into water vapor. The water vapor may be transported through the open areas **120** within the adhesive layer **116** (i.e., the areas not occupied by adhesive) to the exposed or unglued peripheral edges of the structure **100**, where the water vapor can be released. As a result, the various layers of the structure **100** are able to remain laminated to one another. In

contrast, the present inventors have found that where a continuous layer of adhesive is used, the layers tend to delaminate from one another during use.

The discontinuous layer of adhesive **116** may comprise a pattern of adhesive areas, a random (or seemingly random) arrangement of adhesive areas, or
5 any other suitable adhesive configuration. In some embodiments, the adhesive areas may comprise discrete adhesive areas circumscribed by non-adhesive areas, which define the venting passageways **120** in the structure **100**. The adhesive areas may be solid shapes, open shapes that enclose or circumscribe non-adhesive areas (e.g., an annulus), or any combination thereof.

10 In one example, the adhesive areas of the discontinuous adhesive layer **116** may be substantially circular in shape, such that the pattern of adhesive resembles a plurality of dots, for example, as shown in schematic top plan view in **FIG. 1B**. The adhesive “dots” may have any suitable size, spacing, and arrangement. In one exemplary embodiment, the adhesive dots may have a diameter of about 0.0625
15 in. (about 1.59 mm) and may be spaced about 0.0625 in. (about 1.59 mm) apart. In another exemplary embodiment, the adhesive dots may have a diameter of about 0.125 in. (about 3.18 mm) and may be spaced about 0.0625 in. (about 1.59 mm) apart. However, countless other shapes, dimensions, and configurations may be used.

20 In another example, the adhesive areas of the discontinuous adhesive layer **116** may comprise wavy lines, as shown in schematic top plan view in **FIG. 1C**. In such an example, the spaces between the adhesive lines define the passageways for the water vapor to be released from the structure. In still another example, the adhesive areas of the discontinuous adhesive layer **116** may be substantially
25 rectangular in shape, such that the pattern of adhesive resembles a plurality of staggered stripes, for example, as shown in schematic top plan view in **FIG. 1D**. In yet another example, the adhesive areas of the discontinuous adhesive layer **116** may be substantially cross-shaped, as shown in schematic top plan view in **FIG. 1E**. However, numerous other patterns may be used, provided that such patterns

allow the passage of moisture through the open areas **120** in the adhesive layer **116**.

As stated previously, the adjoining layer **114** may be any material, for example, a polymer film, paper, or paperboard. Further, it will be understood that additional layers may be joined to the adjoining layer **114** if desired, as will be
5 evident from the remaining discussion.

Numerous variations of the structure **100** of **FIG. 1A** are contemplated. For example, **FIGS. 2-4A** schematically depict some exemplary variations of the microwave energy interactive structure **100** of **FIG. 1A**. The various structures
10 **200, 300, 400, 800** include features that are similar to structure **100** shown in **FIG. 1A**, except for variations noted and variations that will be understood by those of skill in the art. For simplicity, the reference numerals of similar features are preceded in the figures with a “**2**” (**FIG. 2**), “**3**” (**FIG. 3**), or “**4**” (**FIG. 4A**) instead of a “**1**”.

In the exemplary structure **200** illustrated schematically in **FIG. 2**, the
15 adjoining layer **214** may be a moisture-containing layer, for example, paper or paperboard. The second layer of microwave energy interactive material **218** may be joined to the adjoining layer **214** by a substantially continuous layer of adhesive **222**. The structure **200** may include a second polymer film **224** on a side of the
20 second layer of microwave energy interactive material **218** opposite the adhesive layer **222** to define a second susceptor film **202'**. The outermost surface of the first polymer film **206** or the second polymer film **224** may comprise a food-contacting surface of the respective film layer.

Layers **214, 218, 222, 224** generally define a supported susceptor film **212'**
25 similar to supported susceptor film **212**. The two supported susceptor films **212, 212'** are arranged with their respective moisture-containing layers **208, 214** facing one another on opposite sides of the discontinuous layer of adhesive **216**, such that the structure **200** is generally symmetrical across the discontinuous layer of adhesive **216**. In this example, it is contemplated that the water vapor from both

moisture-containing layers **208, 214** may be transported from the interior of the structure **200** via the discontinuities **220** in the adhesive layer **216**.

In another exemplary structure **300** illustrated schematically in **FIG. 3**, the adjoining layer **314** may be a polymer film. The structure **300** includes a second
5 moisture-containing layer **322** joined to the second layer of microwave energy interactive material **318** with a substantially continuous layer of adhesive **324**. The outermost surface of polymer film **306** may comprise a food-contacting surface of the structure **300**.

Layers **314, 318, 322, 324** generally define a supported susceptor film **312'**
10 similar to the supported susceptor film **312**. In this embodiment, the two supported susceptor films **312, 312'** are in a "stacked" configuration and joined to one another by the discontinuous layer of adhesive **316**.

FIG. 4 schematically illustrates still another exemplary susceptor structure **400**. In this example, the structure **400** includes a supported susceptor film **412**
15 joined to a microwave energy interactive insulating material **422** using a discontinuous layer of adhesive **416**.

The supported susceptor film **412** comprises a susceptor layer **404** supported on a polymer film layer **406** to define a susceptor film **402**. The susceptor film **402** is joined to a moisture-containing layer **408** (e.g., paperboard)
20 with a substantially continuous layer of adhesive **410**.

The microwave energy interactive insulating material **422** includes a susceptor layer **418** supported on a first polymer film **424**, collectively forming a susceptor film **402'**. The susceptor film **402'** is joined to a moisture-containing substrate or support **426** (e.g., paper) using a substantially continuous layer of
25 adhesive **428**, such that layers **418, 424, 426, 428** define a supported susceptor film **412'** similar to supported susceptor film **412**. The microwave energy interactive insulating material **422** also includes an adjoining layer **414**, in this example, a second polymer film **414** joined to the moisture-containing support **426** in a patterned configuration using an adhesive **430** or any other suitable fastening
30 material or technique. The pattern of adhesive **430** generally defines a plurality of

non-adhesive areas surrounded by adhesive areas, such that a plurality of closed cells **432** are formed between the support **426** and the second polymer film **414**. The closed cells **432** are operative for inflating or expanding upon sufficient exposure to microwave energy, as will be discussed further below. In one
5 example, the pattern of adhesive **430** may be a grid pattern, such that the closed cells **432** have a generally square shape. However, any suitable pattern of adhesion and shape of closed cells **432** may be used.

The structures **100**, **200**, **300**, **400** of **FIGS. 1A, 2, 3, 4A** and numerous others encompassed by the present disclosure may be used to form various
10 microwave heating constructs, including, for example, cartons, trays, platforms, disks, sleeves, pouches, and so forth. By way of example, and not limitation, **FIGS. 4B** and **4C** schematically depict partial cutaway views of opposed first and second sides of an exemplary microwave energy interactive construct **434** formed (e.g., cut) from the susceptor structure **400** of **FIG. 4A**. In this example, the
15 construct **434** has a generally circular shape, and therefore may be referred to as a microwave energy interactive heating disk. The construct **434** may be used for heating, browning, and/or crisping a generally circular food item, for example, a pizza, in a microwave oven. However, numerous other regular and irregular shapes are contemplated.

20 To use the construct **434**, the food item **F** (e.g., a pizza) may be placed on a food-contacting surface **436** of the microwave energy interactive insulating material **422** (i.e., on the outermost surface of polymer film **424**, although it is contemplated that the construct **434** may be inverted and the outermost surface of polymer film **406** may comprise the food-contacting surface in other
25 embodiments) and placed in a microwave oven. While not wishing to be bound by theory, it is believed that as the susceptor **418** (shown schematically with stippling in **FIG. 4B**) heats upon impingement by microwave energy, water vapor and other gases typically held in the substrate **426**, for example, paper, and any air trapped in the closed cells **432** between the second polymer film **414** and the
30 substrate **426**, expand, thereby causing the susceptor film **402'** and substrate **426** to

loft or bulge away from the second polymer film **414**, as schematically illustrated in **FIG. 4D** (which depicts only a portion of the microwave energy interactive heating disk **434**). The resulting insulating material **422** has a quilted or pillowed food-contacting side or surface **436**. In this inflated or expanded state, the
5 susceptor **418** is urged towards the surface of the food item (e.g., the bottom surface of the food item **F**), to enhance browning and/or crisping, with the pillowed surface of the insulating material **422** being able to conform more closely to the contours of the food item. For example, where the food item is a pizza, which tends to dome or crown during the freezing process, the expandable cells
10 **432** of the insulating material **422** may be brought into closer proximity with the domed area of the pizza, thereby providing enhanced browning and/or crisping as compared with a flat susceptor sheet. Further, the water vapor and other gases trapped in the cells **432** reduce the amount of heat transferred from the construct **434** to the microwave heating environment, thereby further enhancing heating,
15 browning, and/or crisping of the food item **F**. Additional features of microwave energy interactive insulating materials are described in detail in U.S. Patent No. 7,019,271, U.S. Patent No. 7,351,942, and U.S. Patent Application Publication No. 2008-0078759 A1, published April 3, 2008, each of which is incorporated by reference herein in its entirety. When microwave heating has ceased, the cells **432**
20 typically deflate and return to a somewhat flattened state having a somewhat wrinkled appearance (not shown).

Likewise, upon sufficient exposure to microwave energy, susceptor **404** (shown schematically with stippling in **FIG. 4C**) on the opposite side of the disk **434** converts at least a portion of the impinging microwave energy into thermal
25 energy, which then can be transferred through the paperboard layer **408** towards the lower surface of the food item **F** to enhance browning and/or crisping even further. Any water vapor generated by the heating of the susceptor **404** can be released from the paperboard **408** and transported through the passageways **420** in the discontinuous adhesive layer **416** (**FIG. 4A**) to the exposed edges **438** of the
30 construct **434**.

Various methods of forming the construct **434** are contemplated. In one exemplary method schematically illustrated in **FIG. 4E**, a paperboard base material **408** is unwound from a stock roll (not shown). An adhesive **410** is applied to one side **440** of the paperboard **408** in a substantially continuous configuration. A susceptor film **402** is then applied to the layer of adhesive **410** with the metal layer **404** of the susceptor film **402** facing the adhesive **410** to form the supported susceptor film **412**, which defines the second side of the construct **434**, shown in **FIG. 4C**.

In another operation that may or may not be integrated with the remainder of the process, paper **426** is unwound from a stock roll (not shown). A substantially continuous layer of adhesive **428** is applied to a first side **442** of the paper **426**. A susceptor film **402'** is then applied to the layer of adhesive **428** with the metal layer **418** of the susceptor film **402'** facing the adhesive **428**. An adhesive **430** is then applied to the exposed side (i.e. the second side **444**) of the paper **426** in a grid-like configuration. A polymer film **414** is then applied to the adhesive **430** to define a plurality of substantially closed cells **432** between the paper **426** and the polymer film **414**. This forms the microwave energy interactive insulating material **422** on the first side of the construct (**FIG. 4B**).

Returning to the supported susceptor film **412** previously formed, an adhesive **416** is applied in a patterned configuration (e.g., a dot pattern or other pattern, such as, but not limited to, the adhesive patterns shown in **FIGS. 1B-1E**) to the exposed side **446** of the paperboard **408**. The microwave energy interactive insulating material **422** formed previously is then applied to the layer of adhesive **416** to join the polymer film **414** to the paperboard **408**. This forms the first side (i.e., the food-contacting side) of the construct **434** (**FIG. 4B**).

The web is then sent to a die cutter, where the construct **434** is cut into the desired shape, for example, a circle (e.g., **FIGS. 4B** and **4C**), square, oval triangle, or any other desired shape.

It will be apparent that numerous other sequences of steps may be used to form the construct **434**. It also will be apparent that numerous other microwave

energy interactive insulating materials or structures may be used to form a construct in accordance with the disclosure. Any of such materials may be used alone or in combination, and in any configuration, to form the construct. Where multiple materials (or multiple layers of the same material) are used, the materials
5 may be joined to one another partially or completely, or may remain separate from one another (i.e., unjoined).

For example, **FIG. 5** schematically illustrates another exemplary microwave energy interactive insulating material **522** that may be used instead of the microwave energy interactive insulating material **422** shown in **FIGS. 4A-4D**.
10 In this example, the structure **522** includes a polymer film layer **502**, a susceptor layer **504**, an adhesive layer **506**, and a paper layer **508**. Additionally, the structure **500** includes a second polymer film layer **510**, adhesive layer **512**, and paper layer **514**. The layers may be adhered or affixed by a patterned adhesive **516** that defines a plurality of substantially closed, expandable cells **518** between
15 the paper layers **508**, **514**.

Likewise, **FIG. 6** schematically illustrates yet another exemplary microwave energy interactive insulating material **622** that may be suitable for use instead of the insulating material **422** shown in **FIGS. 4A-4D**. In this example, the insulating material **622** includes a pair of adjoined, symmetrical layer
20 arrangements. If desired, the two symmetrical arrangements may be formed by folding one layer arrangement onto itself.

The first symmetrical layer arrangement, beginning at the top of the drawing, comprises a polymer film layer **602**, a susceptor layer **604**, an adhesive layer **606**, and a paper or paperboard layer **608**. The adhesive layer **606** joins the
25 polymer film **602** and the susceptor layer **604** to the paperboard layer **608**. The second symmetrical layer arrangement, beginning at the bottom of the drawing, also comprises a polymer film layer **610**, a susceptor layer **612**, an adhesive layer **614**, and a paper or paperboard layer **616**. A patterned adhesive layer **618** is provided between the two paper layers **608**, **616** to define a plurality of closed
30 cells **620** that are adapted to inflate when sufficiently exposed to microwave

energy. While not wishing to be bound by theory, it is believed that the additional susceptor layer results in greater heating and expansion of the insulating cells, thereby providing more thermal insulation as compared with an insulating material having a single susceptor layer.

5 It will be recognized that each of the exemplary insulating materials previously described include a moisture-containing layer (e.g. paper) that is believed to release at least a portion of the vapor that inflates the expandable cells. However, it is contemplated that insulating structures without such moisture-containing layers also may be used instead of the insulating material **422** shown in
10 **FIGS. 4A-4D** to form the construct **434** (or any other construct).

For example, **FIG. 7** illustrates one example of an expandable cell insulating material **722** that inflates without the need for a moisture-containing layer, for example, paper. In this example, one or more reagents are used to generate a gas that inflates the cells.

15 A thin layer of microwave interactive material **702** is supported on a first polymer film **704** to form a susceptor film **706**. One or more reagents **708**, optionally within a coating, lie adjacent at least a portion of the layer of microwave interactive material **702**. The reagent **708** coated susceptor film **706** is joined to a second polymer film **710** using a patterned adhesive **712** or other
20 material, or using thermal bonding, ultrasonic bonding, or any other suitable technique, such that closed cells **714** (shown as a void) are formed in the material **700**.

Numerous reagents may be suitable for use in the structure **722**. For example, the reagents may comprise sodium bicarbonate (NaHCO_3) and a suitable
25 acid. When exposed to heat, the reagents react to produce carbon dioxide. As another example, the reagent may comprise a blowing agent. Examples of blowing agents that may be suitable include, but are not limited to, p-p'-oxybis(benzenesulphonylhydrazide), azodicarbonamide, and p-toluenesulfonylsemicarbazide. However, it will be understood that numerous
30 other reagents and released gases are contemplated hereby.

As the microwave energy interactive material **702** heats upon impingement by microwave energy, water vapor or other gases are released from (or generated by) the reagent **708**, thereby exerting pressure on the susceptor film **706** on one side and the second polymer film **710** on the other side of the closed cells **714**, as
5 discussed in connection with the various other insulating materials described above. Even without a paper or paperboard layer, the gas resulting from the reagent is sufficient both to inflate the expandable cells and to absorb any excess heat from the susceptor. Such materials are described further in U.S. Patent Application Publication No. 20060278521A1, which is incorporated by reference
10 herein in its entirety.

Countless other microwave energy interactive structures and constructs are contemplated by the disclosure. If desired, any of such structures may include one or more areas that are transparent to microwave energy. Such microwave energy transparent areas transmit microwave energy and, in some instances, may cause
15 the formation of localized electric fields that enhance heating, browning, and/or crisping of an adjacent food item. The transparent areas may be sized, positioned, and/or arranged to customize the heating, browning, and/or crisping of a particular area of the food item to be heated.

For example, **FIG. 8A** schematically illustrates a top plan view of another
20 microwave heating construct **800** (e.g., a microwave heating disk) that generally includes a susceptor **802** (shown schematically with stippling) that circumscribes a plurality of microwave energy transparent areas **804**, **806** (shown schematically in white). In this example, the disk **800** has a substantially circular shape. However, any regular or irregular shape may be used.

25 The disk **800** includes a central region **808** and a peripheral region **810**. In the central region **808** of the disk **800**, the microwave energy transparent areas **804** are substantially circular in shape, with the concentration of microwave energy transparent areas **804** decreasing from the center of the disk **800** outwardly towards the peripheral region **810**. However, other configurations are
30 contemplated. In the peripheral region **810**, the microwave energy transparent

areas **806** are substantially square in shape and arranged in rows and columns, such that the microwave energy interactive material in the peripheral region **810** has a grid-like appearance. As stated above, the percent transparent area may be varied as needed to achieve the desired heating, browning, and/or crisping of the food item. Such areas may be formed in any suitable manner, as will be described below.

FIG. 8B schematically illustrates a cross-sectional view of a portion of the microwave heating disk **800** of **FIG. 8A**. The microwave heating disk **800** includes a pair of microwave energy interactive elements **802a**, **802b**, for example, susceptors, supported on respective microwave energy transparent substrates **812a**, **812b**, for example, polymer film layers, to collectively define respective susceptor films or susceptor film layers **814a**, **814b**. Susceptor **802a** circumscribes at least one, and in some examples, a plurality, of microwave energy transparent (i.e., inactive) areas **804** (or **806**, **FIG. 8A**).

Each susceptor is joined respectively to a respective microwave energy transparent, dimensionally stable support or support layer **816a**, **816b**, for example, paper, using a respective substantially continuous adhesive layer **818a**, **818b** to define respective supported susceptor films **820a**, **820b**. The supported susceptor films **820a**, **820b** may be joined to one another using a discontinuous layer of adhesive **822** (e.g., a dot pattern or other pattern, such as, but not limited to, the adhesive patterns shown in **FIGS. 1B-1E**). In turn, support layer **816b** is joined to a double faced corrugated material **824**, which includes a plurality of flutes or corrugations **826** between facing layers **828a**, **828b**.

In the illustrated embodiment, the support layer **816b** is joined to the facing layer **828a** using a discontinuous layer of adhesive **830**. However, in some embodiments, the layer of adhesive **830** may be substantially continuous. While not wishing to be bound by theory, it is believed that some facing layers **828a** are somewhat textured and/or porous, which may allow water vapor to be vented from the support layer **816b** without causing delamination of the layers **816b**, **828a**.

In another embodiment (not shown), the support layer **816b** and discontinuous adhesive layer **830** may be omitted, such that the susceptor film **814b** is joined directly to the facing layer **828a**. In such a case, the layer of adhesive **818b** joining the susceptor film **814b** to the facing layer **828a** may be substantially continuous (as shown).

Numerous other microwave heating constructs are encompassed by the disclosure. Any of such structures or constructs may be formed from various materials, provided that the materials are substantially resistant to softening, scorching, combusting, or degrading at typical microwave oven heating temperatures, for example, at from about 250°F to about 425°F. The materials may include microwave energy interactive materials, for example, those used to form susceptors and other microwave energy interactive elements, and microwave energy transparent or inactive materials, for example, those used to form the remainder of the construct.

The microwave energy interactive material may be an electroconductive or semiconductive material, for example, a metal or a metal alloy provided as a metal foil; a vacuum deposited metal or metal alloy; or a metallic ink, an organic ink, an inorganic ink, a metallic paste, an organic paste, an inorganic paste, or any combination thereof. Examples of metals and metal alloys that may be suitable include, but are not limited to, aluminum, chromium, copper, inconel alloys (nickel-chromium-molybdenum alloy with niobium), iron, magnesium, nickel, stainless steel, tin, titanium, tungsten, and any combination or alloy thereof.

Alternatively, the microwave energy interactive material may comprise a metal oxide, for example, oxides of aluminum, iron, and tin, optionally used in conjunction with an electrically conductive material. Another metal oxide that may be suitable is indium tin oxide (ITO). ITO has a more uniform crystal structure and, therefore, is clear at most coating thicknesses.

Alternatively still, the microwave energy interactive material may comprise a suitable electroconductive, semiconductive, or non-conductive artificial dielectric or ferroelectric. Artificial dielectrics comprise conductive, subdivided

material in a polymeric or other suitable matrix or binder, and may include flakes of an electroconductive metal, for example, aluminum.

While susceptors are illustrated herein, the construct also may include a foil or high optical density evaporated material having a thickness sufficient to reflect a substantial portion of impinging microwave energy. Such elements are typically formed from a conductive, reflective metal or metal alloy, for example, aluminum, copper, or stainless steel, in the form of a solid "patch" generally having a thickness of from about 0.000285 inches to about 0.05 inches, for example, from about 0.0003 inches to about 0.03 inches. Other such elements may have a thickness of from about 0.00035 inches to about 0.020 inches, for example, 0.016 inches.

Larger microwave energy reflecting elements may be used where the food item is prone to scorching or drying out during heating and therefore, may be referred to as shielding elements. Smaller microwave energy reflecting elements may be used to diffuse or lessen the intensity of microwave energy. A plurality of smaller microwave energy reflecting elements also may be arranged to form a microwave energy directing element to direct microwave energy to specific areas of the food item. If desired, the loops may be of a length that causes microwave energy to resonate, thereby enhancing the distribution effect. Microwave energy distributing elements are described in U.S. Patent Nos. 6,204,492, 6,433,322, 6,552,315, and 6,677,563, each of which is incorporated by reference in its entirety.

If desired, any of the numerous microwave energy interactive elements described herein or contemplated hereby may be substantially continuous, that is, without substantial breaks or interruptions, or may be discontinuous, for example, by including one or more breaks or apertures that transmit microwave energy therethrough. The breaks or apertures may be sized and positioned to heat particular areas of the food item selectively. The breaks or apertures may extend through the entire structure, or only through one or more layers. The number, shape, size, and positioning of such breaks or apertures may vary for a particular

application depending on the type of construct being formed, the food item to be heated therein or thereon, the desired degree of shielding, browning, and/or crisping, whether direct exposure to microwave energy is needed or desired to attain uniform heating of the food item, the need for regulating the change in
5 temperature of the food item through direct heating, and whether and to what extent there is a need for venting.

It will be understood that the aperture may be a physical aperture or void in one or more layers or materials used to form the construct, or may be a non-physical "aperture" (not shown). A non-physical aperture is a microwave energy
10 transparent area (e.g., microwave energy transparent areas **804**, **806**) that allows microwave energy to pass through the structure without an actual void or hole cut through the structure. Such areas may be formed by simply not applying microwave energy interactive material to the particular area, or by removing microwave energy interactive material in the particular area, or by mechanically
15 deactivating the particular area (rendering the area electrically discontinuous). Alternatively, the areas may be formed by chemically deactivating the microwave energy interactive material in the particular area, thereby transforming the microwave energy interactive material in the area into a substance that is transparent to microwave energy (i.e., microwave energy inactive). While both
20 physical and non-physical apertures allow the food item to be heated directly by the microwave energy, a physical aperture also provides a venting function to allow steam or other vapors to escape from the interior of the construct.

The arrangement of microwave energy interactive and microwave energy transparent areas may be selected to provide various levels of heating, as needed
25 or desired for a particular application. For example, where greater heating is desired, the total inactive (i.e., microwave energy transparent) area may be increased. In doing so, more microwave energy is transmitted to the food item. Alternatively, by decreasing the total inactive area, more microwave energy is absorbed by the microwave energy interactive areas, converted into thermal

energy, and transmitted to the surface of the food item to enhance heating, browning, and/or crisping.

In some instances, it may be beneficial to create one or more discontinuities or inactive regions to prevent overheating or charring of the construct. Such areas may be formed by forming these areas of the construct
5 without a microwave energy interactive material, by removing any microwave energy interactive material that has been applied, or by deactivating the microwave energy interactive material in these areas, as discussed above.

Further still, one or more panels, portions of panels, or portions of the
10 construct may be designed to be microwave energy inactive to ensure that the microwave energy is focused efficiently on the areas to be heated, browned, and/or crisped, rather than being lost to portions of the food item not intended to be browned and/or crisped or to the heating environment. This may be achieved using any suitable technique, such as those described above.

As stated above, the microwave energy interactive material (e.g.,
15 susceptors **104, 118, 204, 218, 304, 318, 404, 418, 504, 604, 612, 702, 802a, 802b**) may be supported on a microwave inactive or transparent substrate (e.g., polymer films **106, 206, 224, 306, 314, 406, 424, 502, 602, 610, 704, 812a, 812b**) for ease of handling and/or to prevent contact between the microwave energy
20 interactive material and the food item. The outermost surface of the polymer film may define at least a portion of the food-contacting surface of the package (e.g., surface **436** of polymer film **424**). Examples of polymer films that may be suitable include, but are not limited to, polyolefins, polyesters, polyamides, polyimides, polysulfones, polyether ketones, cellophanes, or any combination
25 thereof. In one particular example, the polymer film comprises polyethylene terephthalate. The thickness of the film generally may be from about 35 gauge to about 10 mil. In each of various examples, the thickness of the film may be from about 40 to about 80 gauge, from about 45 to about 50 gauge, about 48 gauge, or any other suitable thickness. Other non-conducting substrate materials such as

paper and paper laminates, metal oxides, silicates, cellulose, or any combination thereof, also may be used.

The microwave energy interactive material may be applied to the substrate in any suitable manner, and in some instances, the microwave energy interactive material is printed on, extruded onto, sputtered onto, evaporated on, or laminated to the substrate. The microwave energy interactive material may be applied to the substrate in any pattern, and using any technique, to achieve the desired heating effect of the food item. For example, the microwave energy interactive material may be provided as a continuous or discontinuous layer or coating including circles, loops, hexagons, islands, squares, rectangles, octagons, and so forth.

Numerous materials may serve as a moisture-containing layer (e.g., moisture-containing layers **108, 208, 214, 308, 408, 816a**) in the various structures and constructs. In one example, the moisture-containing layer comprises paper having basis weight of from about 15 to about 60 lbs/ream (lb/3000 sq. ft.), for example, from about 20 to about 40 lbs/ream. In another example, the paper has a basis weight of about 25 lbs/ream. In another example, the moisture-containing layer comprises paperboard having a basis weight of from about 60 to about 330 lbs/ream, for example, from about 80 to about 140 lbs/ream. The paperboard generally may have a thickness of from about 6 to about 30 mils, for example, from about 12 to about 28 mils. In one particular example, the paperboard has a thickness of about 12 mils. Any suitable paperboard may be used, for example, a solid bleached or solid unbleached sulfate board, such as SUS® board, commercially available from Graphic Packaging International.

The package may be formed according to numerous processes known to those in the art, including using adhesive bonding, thermal bonding, ultrasonic bonding, mechanical stitching, or any other suitable process. Any of the various components used to form the package may be provided as a sheet of material, a roll of material, or a die cut material in the shape of the package to be formed (e.g., a blank).

It will be understood that with some combinations of elements and materials, the microwave energy interactive element may have a grey or silver color that is visually distinguishable from the substrate or the support. However, in some instances, it may be desirable to provide a package having a uniform color and/or appearance. Such a package may be more aesthetically pleasing to a consumer, particularly when the consumer is accustomed to packages or containers having certain visual attributes, for example, a solid color, a particular pattern, and so on. Thus, for example, the present disclosure contemplates using a silver or grey toned adhesive to join the microwave energy interactive element to the support, using a silver or grey toned support to mask the presence of the silver or grey toned microwave energy interactive element, using a dark toned substrate, for example, a black toned substrate, to conceal the presence of the silver or grey toned microwave energy interactive element, overprinting the metallized side of the polymer film with a silver or grey toned ink to obscure the color variation, printing the non-metallized side of the polymer film with a silver or grey ink or other concealing color in a suitable pattern or as a solid color layer to mask or conceal the presence of the microwave energy interactive element, or any other suitable technique or combination of techniques.

The disclosure may be understood further from the following example, which is not intended to be limiting in any manner.

EXAMPLE 1

Two supported susceptor films were joined to one another with their respective paper support layers facing one another using a continuous layer of adhesive. The resulting structure was heated without a load (i.e., without a food item) in a microwave oven for about 20 seconds. The layers of the structure began to delaminate and loft away from one another.

The supported susceptor films then were joined to one another with their respective paper support layers facing one another using a patterned adhesive. In particular, the patterned adhesive consisted of a dot pattern, where the dots had a

diameter of about 0.125 in. and a spacing of about 0.0625 in. The resulting structure was heated without a load (i.e., without a food item) in a microwave oven for about 20 seconds. The layers of the structure remained intact.

5

EXAMPLE 2

A first supported susceptor film comprising a metalized polyethylene terephthalate film joined to paperboard was pressed into a tray including a pair of elevated platforms. Such trays are described in U.S. Patent Application Publication Nos. US 2008/0164178 A1, published July 10, 2008, and US
10 2008/0000896 A1, published January 3, 2008, which are incorporated by reference herein in their entirety. The tray was used to heat a 10" Tombstone pizza in a microwave oven for about 5 minutes. The bottom crust of the pizza was browned and or crisped acceptably.

A second tray was formed by joining a second supported susceptor film to
15 the first supported susceptor film. The second supported susceptor film included a metalized polyethylene terephthalate film joined to paper. The first and second supported susceptor films were joined to one another with the paperboard and paper layer facing one another using the dot adhesive pattern described in Example 1. The tray was used to heat a 10" Tombstone pizza in a microwave
20 oven for about 5 minutes. The bottom crust of the pizza was browned and or crisped exceptionally. Thus, although the single susceptor tray produced suitable results, the dual susceptor structure achieved superior browning and crisping of the pizza crust.

While the present invention is described herein in detail in relation to
25 specific aspects and embodiments, it is to be understood that this detailed description is only illustrative and exemplary of the present invention and is made merely for purposes of providing a full and enabling disclosure of the present invention and to set forth the best mode of practicing the invention known to the inventors at the time the invention was made. The detailed description set forth
30 herein is illustrative only and is not intended, nor is to be construed, to limit the

present invention or otherwise to exclude any such other embodiments, adaptations, variations, modifications, and equivalent arrangements of the present invention. All directional references (e.g., upper, lower, upward, downward, left, right, leftward, rightward, top, bottom, above, below, vertical, horizontal, clockwise, and counterclockwise) are used only for identification purposes to aid the reader's understanding of the various embodiments of the present invention, and do not create limitations, particularly as to the position, orientation, or use of the invention unless specifically set forth in the claims. Joinder references (e.g., joined, attached, coupled, connected, and the like) are to be construed broadly and may include intermediate members between a connection of elements and relative movement between elements. As such, joinder references do not necessarily imply that two elements are connected directly and in fixed relation to each other. Further, various elements discussed with reference to the various embodiments may be interchanged to create entirely new embodiments coming within the scope of the present invention.

What is claimed is:

1. A microwave energy interactive structure comprising:
 - a first susceptor film comprising a first layer of microwave energy interactive material supported on a first polymer film;
 - a moisture-containing layer joined to the first layer of microwave energy interactive material;
 - an adjoining layer joined to the moisture-containing layer such that the moisture-containing layer is disposed between the susceptor film and the adjoining layer, the adjoining layer being joined to the moisture-containing layer by a discontinuous adhesive layer, wherein the discontinuous adhesive layer comprises a plurality of joined areas, each joined area being circumscribed by an unjoined area; and
 - a second layer of microwave energy interactive material on a side of the adjoining layer opposite the moisture-containing layer.
2. The structure of claim 1, further comprising a plurality of peripheral edges, the peripheral edges being at least partially in open communication with the unjoined areas between the moisture-containing layer and the adjoining layer.
3. The structure of claim 2, wherein the peripheral edges in open communication with the unjoined areas between the moisture-containing layer and the adjoining layer define passageways for venting moisture released from the moisture-containing layer.
4. The structure of claim 1 or 2, wherein the moisture-containing layer comprises paper or paperboard.

5. The structure of claim 1 or 2, wherein the moisture-containing layer is joined to the first layer of microwave energy interactive material by a substantially continuous layer of adhesive.
6. The structure of claim 1 or 2, wherein the adjoining layer is a moisture-containing layer.
7. The structure of claim 6, wherein the adjoining layer comprises paper or paperboard.
8. The structure of claim 7, wherein the second layer of microwave energy interactive material is joined to the adjoining layer by a substantially continuous layer of adhesive.
9. The structure of claim 8, wherein
the polymer film is a first polymer film, and
the structure further comprises a second polymer film on a side of the second layer of microwave energy interactive material opposite the adjoining layer.
10. The structure of claim 1 or 2, wherein the adjoining layer comprises a second polymer film.
11. The structure of claim 10, wherein
the moisture-containing layer is a first moisture-containing layer, and
the structure further comprises a second moisture-containing layer on a side of the second layer of microwave energy interactive material opposite the second polymer film.

12. The structure of claim 11, wherein the second moisture-containing layer is joined to the second layer of microwave energy interactive material by a substantially continuous layer of adhesive.
13. The structure of claim 11, further comprising a corrugated material joined to the second moisture-containing layer on a side of the moisture-containing layer opposite the second layer of microwave energy interactive material.
14. The structure of claim 13, wherein the corrugated material is a double faced corrugated material.
15. The structure of claim 13, wherein the corrugated material is joined to the second moisture-containing layer by a discontinuous adhesive layer, wherein the discontinuous adhesive layer comprises a plurality of joined areas, each joined area being circumscribed by an unjoined area.
16. The structure of claim 13, wherein the first layer of microwave energy interactive material circumscribes a plurality of microwave energy transparent areas.
17. The structure of claim 16, wherein the plurality of microwave energy transparent areas includes a first plurality of microwave energy transparent areas defining a peripheral region of the structure and a plurality of second microwave energy transparent areas defining a central area of the structure.
18. The structure of claim 17, wherein each microwave energy transparent area of the first plurality of microwave energy transparent areas is substantially square in shape, such that the microwave energy interactive material has a substantially grid shape.

19. The structure of claim 17, wherein each microwave energy transparent area of the second plurality of microwave energy transparent areas is substantially circular in shape.
20. The structure of claim 17, wherein the structure comprises a microwave heating disk.
21. The structure of claim 20, wherein the first polymer film is for contacting a food item.
22. The structure of claim 1 or 2, wherein
the adjoining layer comprises a second polymer film,
the moisture-containing layer is a first moisture-containing layer, and
the structure further comprises
 - a second moisture-containing layer disposed between the second polymer film and the second layer of microwave energy interactive material, the second moisture-containing layer being joined to the second polymer film by a patterned adhesive that defines a plurality of closed cells between the second-moisture containing layer and the polymer film, each closed cell comprising an unjoined area, and
 - a third polymer film on a side of the second layer of microwave energy interactive material opposite the second moisture-containing layer.
23. The structure of claim 22, wherein the closed cells are for inflating in response to sufficient exposure to microwave energy.
24. The structure of claim 22, wherein the third polymer film is for contacting a food item.

25. The structure of claim 22, wherein the first polymer film is for contacting a food item.

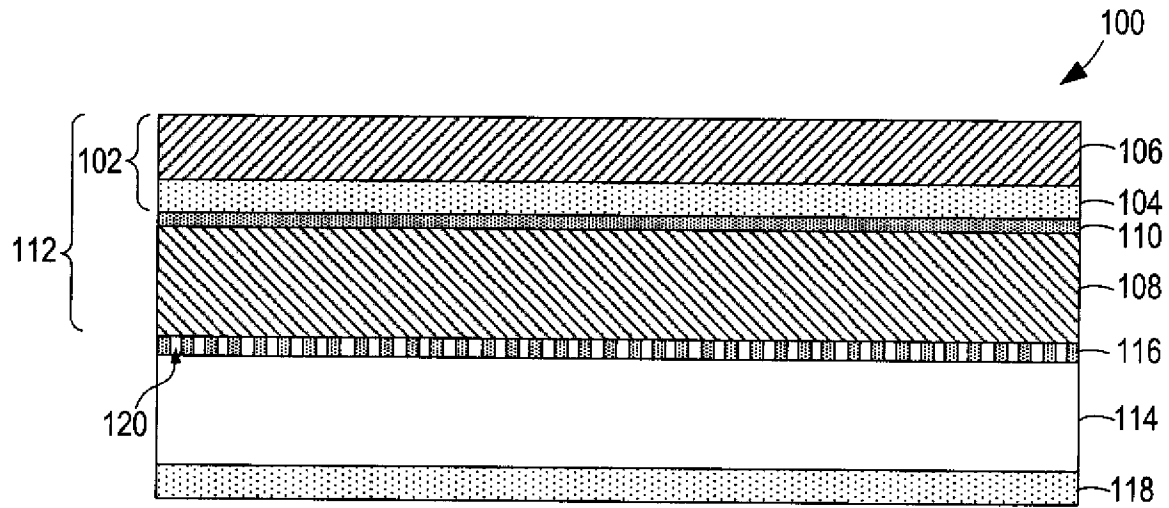

FIG. 1A

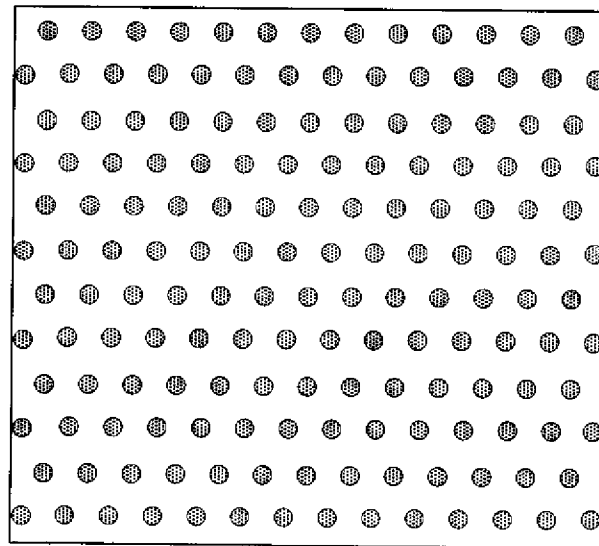

FIG. 1B

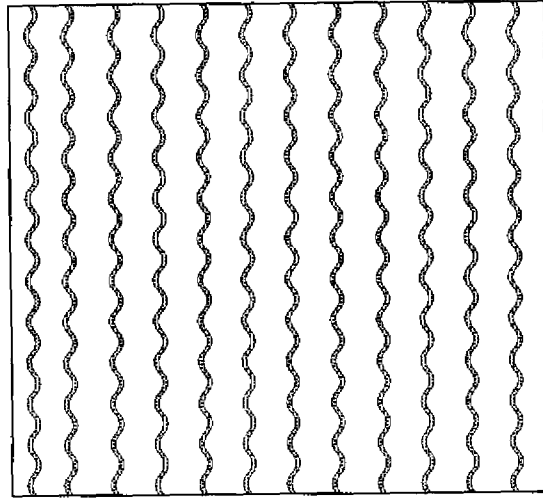

FIG. 1C

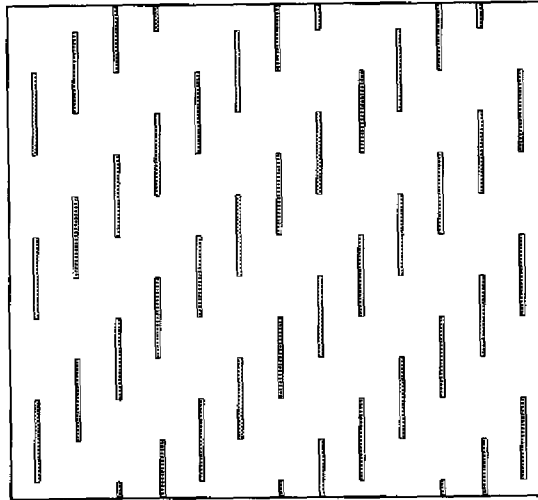

FIG. 1D

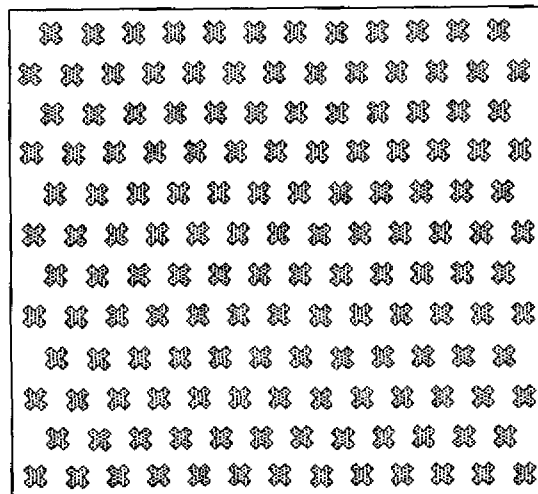

FIG. 1E

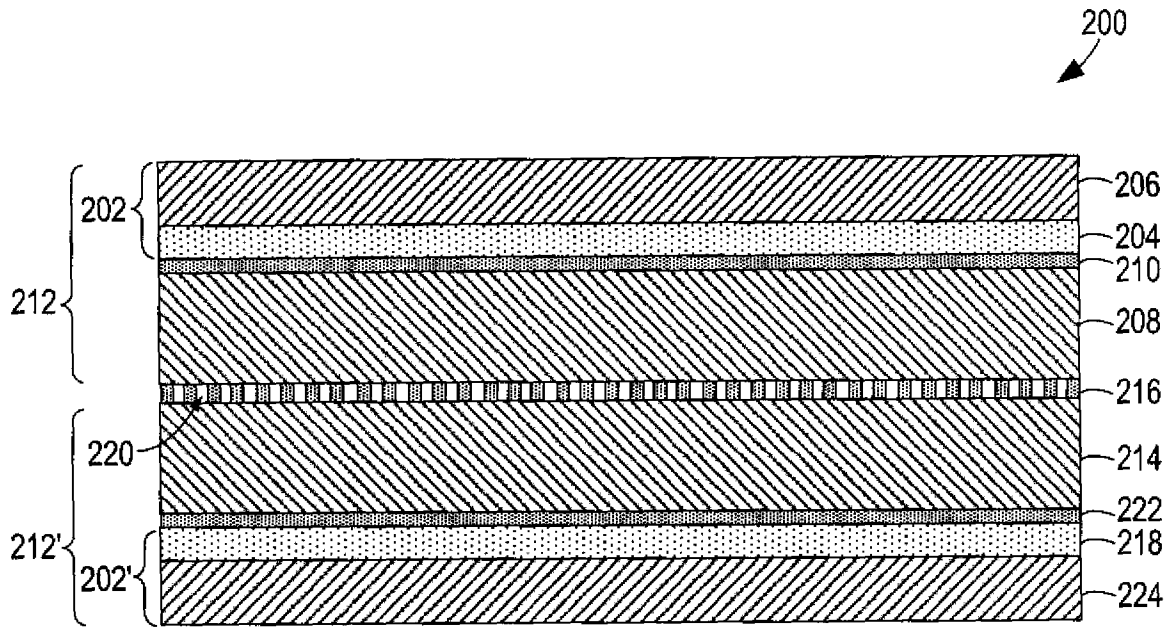

FIG. 2

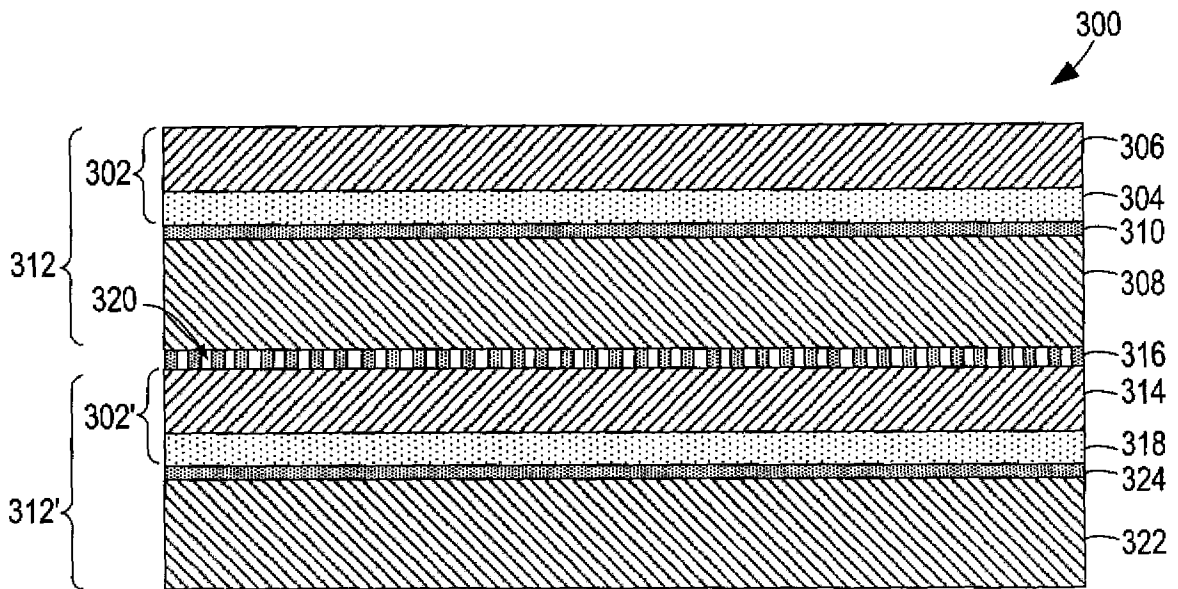

FIG. 3

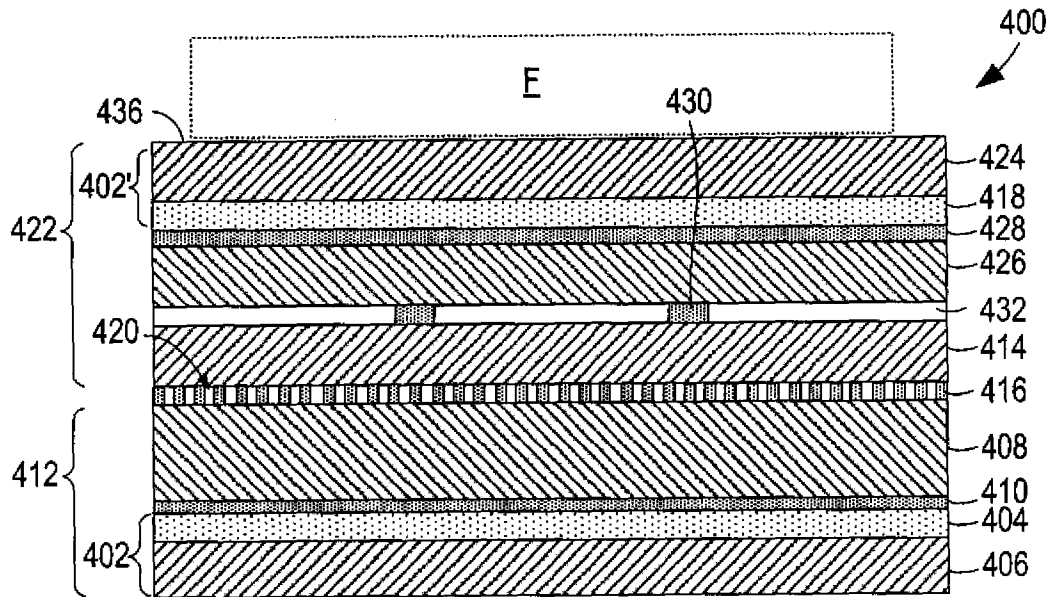

FIG. 4A

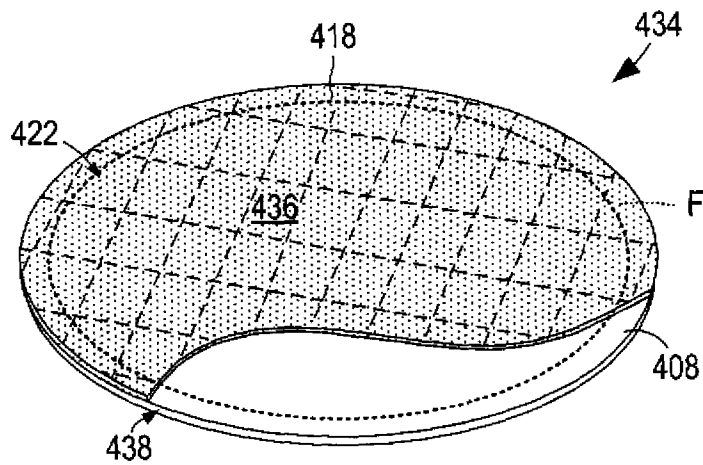

FIG. 4B

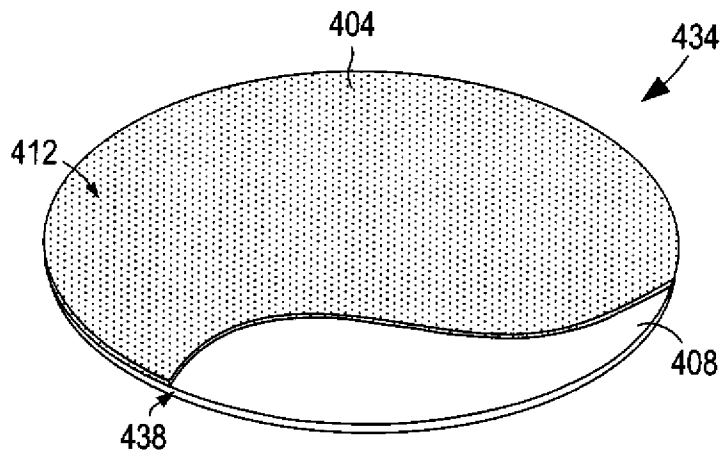

FIG. 4C

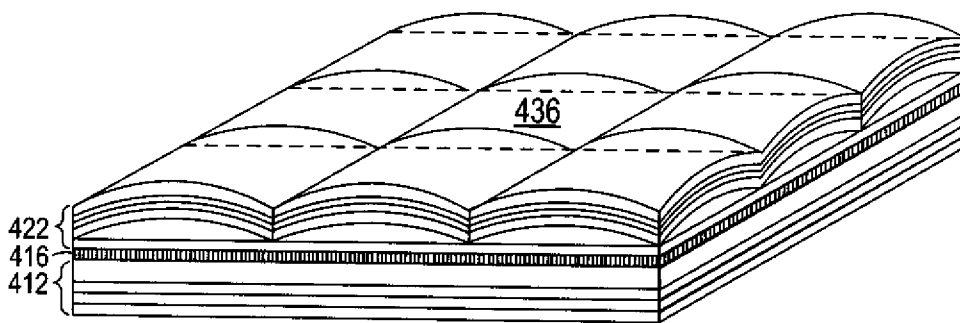

FIG. 4D

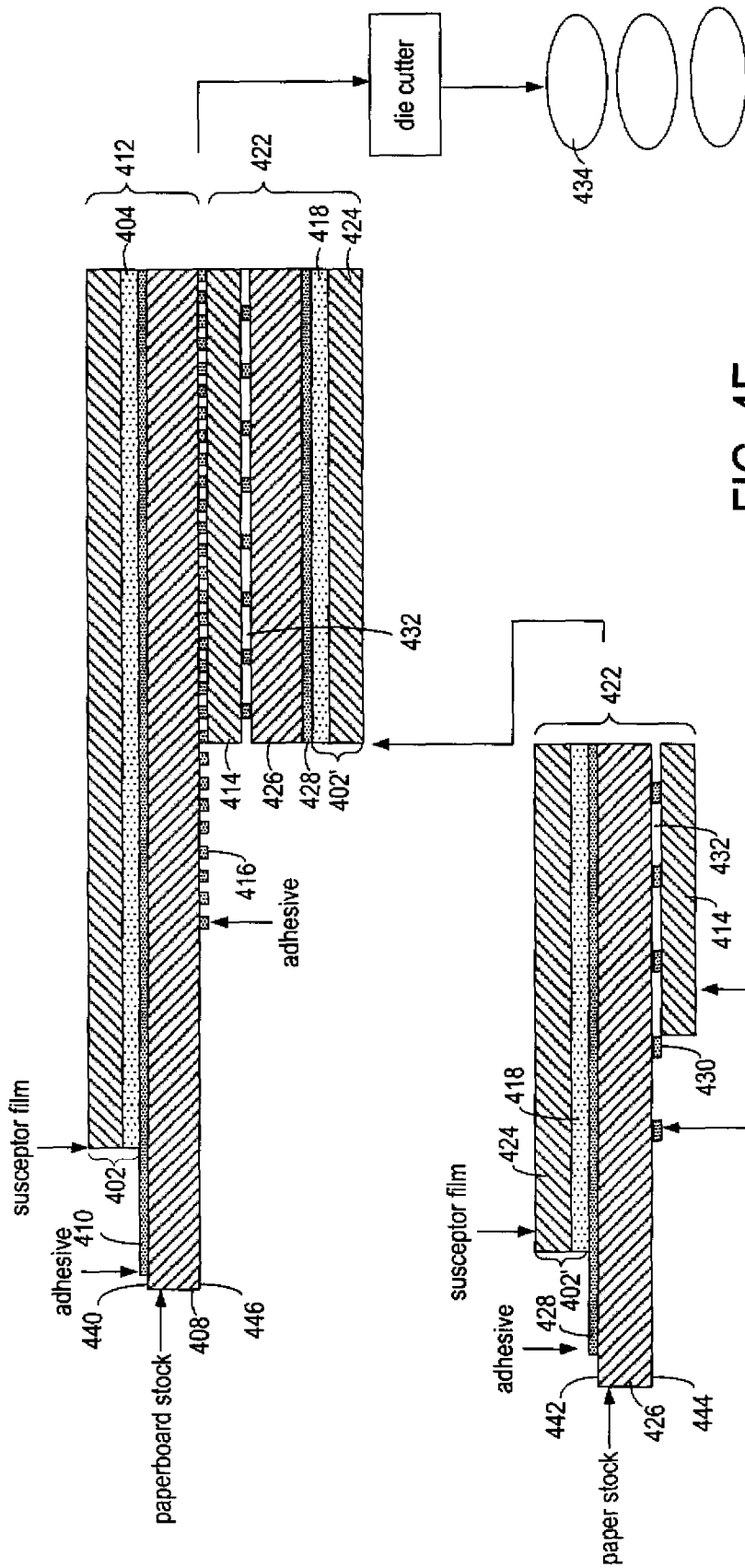

FIG. 4E

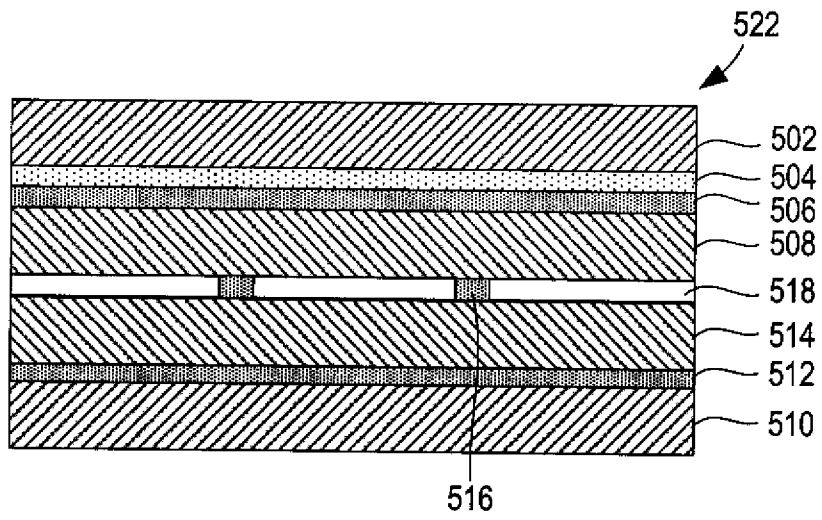

FIG. 5

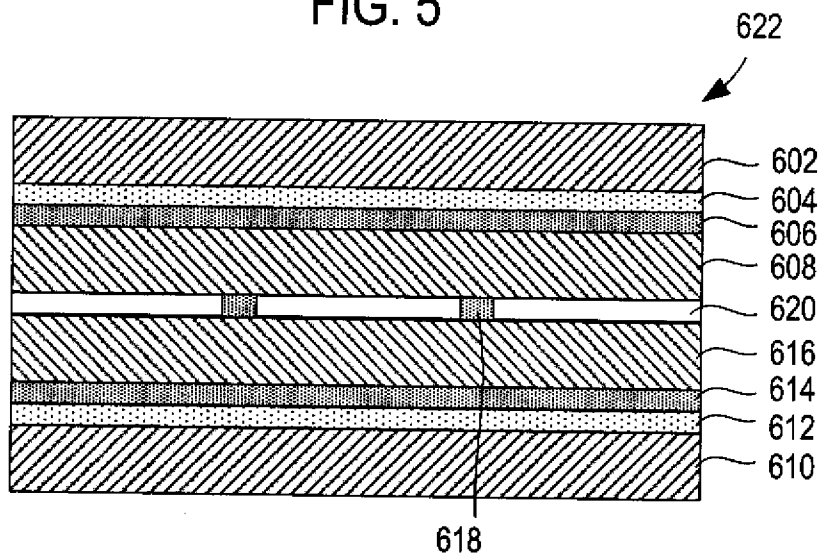

FIG. 6

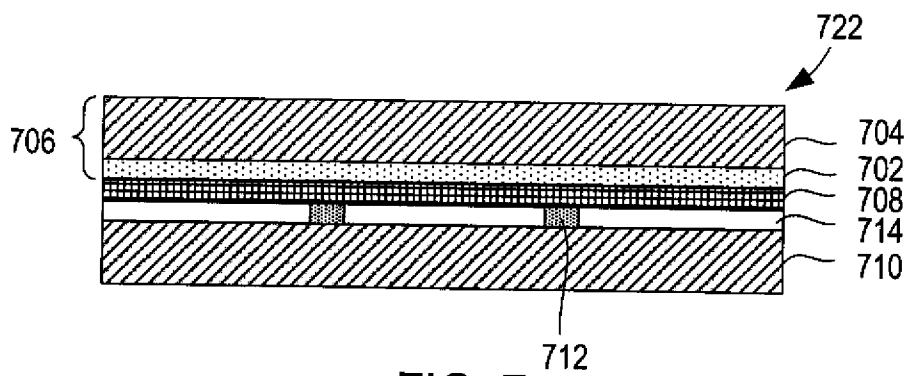

FIG. 7

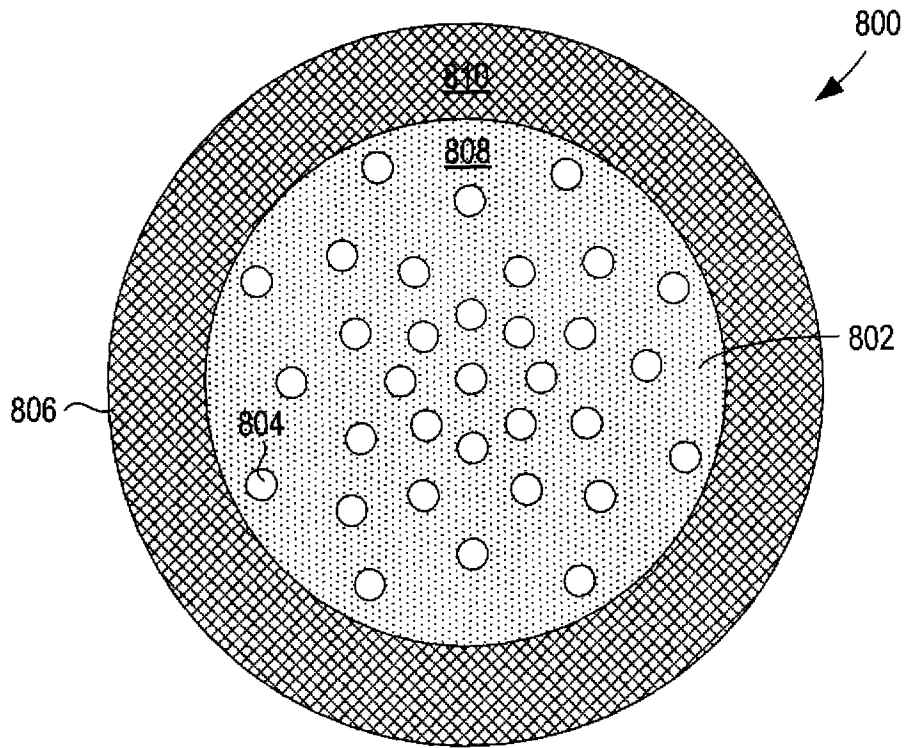

FIG. 8A

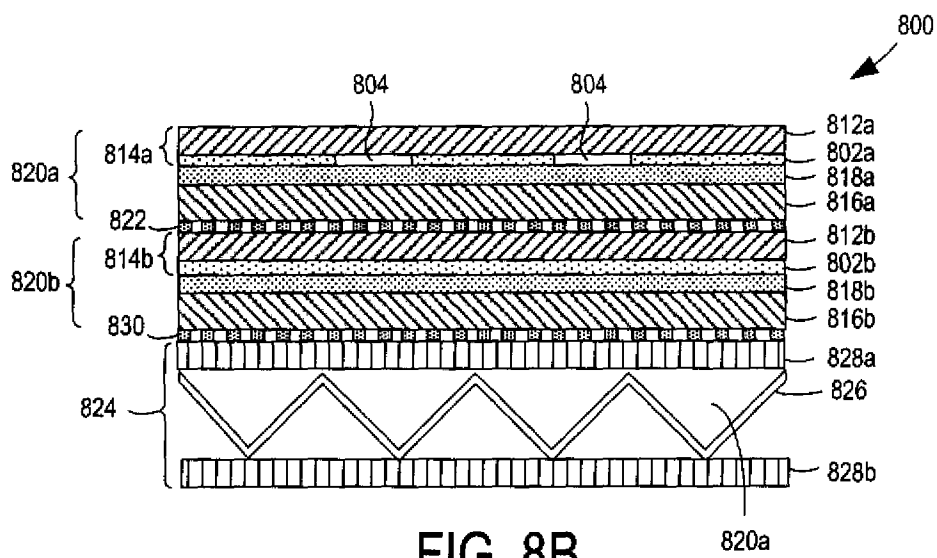

FIG. 8B