

(12) 特許協力条約に基づいて公開された国際出願

(19) 世界知的所有権機関
国際事務局



(43) 国際公開日
2011年4月21日(21.04.2011)

(10) 国際公開番号
WO 2011/045992 A1

- (51) 国際特許分類:
E04F 15/02 (2006.01)
- (21) 国際出願番号: PCT/JP2010/065311
- (22) 国際出願日: 2010年9月7日(07.09.2010)
- (25) 国際出願の言語: 日本語
- (26) 国際公開の言語: 日本語
- (30) 優先権データ:
特願 2009-238648 2009年10月15日(15.10.2009) JP
- (71) 出願人(米国を除く全ての指定国について): WPCコーポレーション株式会社(WPC Corporation) [JP/JP]; 〒1080073 東京都港区三田五丁目7番12-604号 Tokyo (JP).
- (72) 発明者; および
- (75) 発明者/出願人(米国についてのみ): 菊池 武恭(KIKUCHI, Takeyasu) [JP/JP]; 〒1080073 東京都港区三田五丁目7番12-604号WPCコーポレーション株式会社内 Tokyo (JP). 府川 誠一(FUKAWA, Seiichi) [JP/JP]; 〒1080073 東京都港区三田五丁目7番12-604号WPCコーポレーション株式会社内 Tokyo (JP). 中村 雄一郎(NAKAMURA, Yuichiro) [JP/JP]; 〒1080073 東京都港区三田五丁目7番12-604号WPCコーポレーション株式会社内 Tokyo (JP).
- (74) 代理人: 小倉 正明(OGURA, Masaaki); 〒1050004 東京都港区新橋5丁目13番4号YMG新橋ビル5階 Tokyo (JP).
- (81) 指定国(表示のない限り、全ての種類の国内保護が可能): AE, AG, AL, AM, AO, AT, AU, AZ, BA, BB, BG, BH, BR, BW, BY, BZ, CA, CH, CL, CN, CO, CR, CU, CZ, DE, DK, DM, DO, DZ, EC, EE, EG, ES, FI, GB, GD, GE, GH, GM, GT, HN, HR, HU, ID, IL, IN, IS, KE, KG, KM, KN, KP, KR, KZ, LA, LC, LK, LR, LS, LT, LU, LY, MA, MD, ME, MG, MK, MN, MW, MX, MY, MZ, NA, NG, NI, NO, NZ, OM, PE, PG, PH, PL, PT, RO, RS, RU, SC, SD, SE, SG, SK, SL, SM, ST, SV, SY, TH, TJ, TM, TN, TR, TT, TZ, UA, UG, US, UZ, VC, VN, ZA, ZM, ZW.
- (84) 指定国(表示のない限り、全ての種類の広域保護が可能): ARIPO (BW, GH, GM, KE, LR, LS, MW, MZ, NA, SD, SL, SZ, TZ, UG, ZM, ZW), ユーラシア (AM, AZ, BY, KG, KZ, MD, RU, TJ, TM), ヨーロッパ (AL, AT, BE, BG, CH, CY, CZ, DE, DK, EE, ES, FI, FR, GB, GR, HR, HU, IE, IS, IT, LT, LU, LV, MC, MK, MT, NL, NO, PL, PT, RO, SE, SI, SK, SM, TR), OAPI (BF,

[続葉有]

(54) Title: FLOORBOARD FIXING DEVICE

(54) 発明の名称: 床板固定具

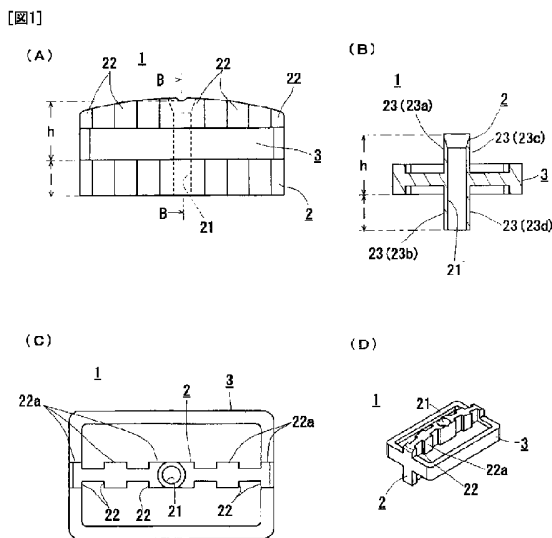

(57) Abstract: Provided is a floorboard fixing device which restricts floorboard movement caused by external force that is caused by everyday use and which, when expansion, shrinkage, or the like occurs in a floorboard, is capable of fixing the floorboard onto a support member like a joist in such a way as to be able to permit movement of the floorboard. More specifically, provided is a floorboard fixing device (1) that fixes a floorboard (4) wherein a slit (41) is longitudinally formed on both side surfaces (40) in the width direction. A bridge piece (3) and a spacer piece (2) are integrally formed by a flexible synthetic resin material into an approximately cross shape, the aforementioned bridge piece (3) being to insert into the slit (41) formed on the side surface (40) of each of two floorboards which are disposed adjacent to each other, and the aforementioned spacer piece (2) protruding toward the front surface and the back surface of each floorboard from an intermediate position, in the width direction, of the bridge piece (3) and being held between the side surfaces of the two floorboards. There is formed an insertion hole (21) which is cut through the spacer piece (2). A fastener is inserted into the insertion hole (21). On a side surface (23) of the spacer piece (2), this side

surface (23) being in contact with the side surface (40) of one of the floorboards, there are formed, in the direction which perpendicularly intersects with the longitudinal direction of the aforementioned side surface (40) of the floorboard, a plurality of protrusions (22, 22') which form a row of protrusions located at predetermined intervals.

(57) 要約:

[続葉有]

WO 2011/045992 A1



BJ, CF, CG, CI, CM, GA, GN, GQ, GW, ML, MR, NE, 添付公開書類:
SN, TD, TG).

— 国際調査報告 (条約第 21 条(3))

通常使用で生じる外力による床板の移動を規制するが、床板の膨張、収縮等が生じた時には床板の移動を許容し得る状態で根太等の支持材上に床板を固定することができる床板固定具を提供する。幅方向の両側面 4 0 それぞれに、長さ方向にスリット 4 1 が形成された床板 4 を固定する床板固定具 1 であり、隣接配置された 2 枚の床板のそれぞれの側面に形成されたスリットに挿入される架橋片 3 と、この架橋片の幅方向における中間位置より床板表裏面方向に突出し床板両側面間に挟持されるスペーサ片 2 を可撓性合成樹脂材料で断面略十字状に一体形成され、前記スペーサ片を貫通する挿孔 2 1 を形成し、該挿孔に固着具を挿入する。前記床板の側面 4 0 と接触する前記スペーサ片 2 の側面 2 3 には、前記床板側面の長さ方向に直交する方向に、所定間隔で列条を成す凸条 2 2、2 2' を複数形成する。

FLOORBOARD FIXING DEVICE

Field of the Invention

The present invention relates to a floorboard fixing device for fixing floorboards (hereinafter called "floorboard fixture") used indoors or outdoors as for example, wooden decks or floors and each having slits that are formed in side surfaces located at opposite widthwise ends and that extend in the longitudinal direction of the floorboard, onto support members such as joists, by using fasteners such as screws, nails, or threaded nails, and particularly to a floorboard fixture suitable for fixing floorboards formed of synthetic wood based on a method according to Japanese Patent No. 3,543,021 or the like.

Description of the Related Art

With reference to a wooden deck as an example, as shown in Fig. 7, a wooden-deck construction process involves, for example, setting posts 6 upright on an installation surface 9 serving as a foundation formed by pouring concrete on the ground as needed, setting support members 5 such as joists on the posts 6, arranging deck panels serving as floorboards 4 parallel to each other in a certain direction at a predetermined interval on the support members 5, and fixing the floorboards 4 to the support members 5.

The simplest technique for fixing the floorboards 4 to the support members 5 involves driving fasteners such as nails or threaded nails 7' which extend from the upper surfaces of the floorboards 4 to the support members 5 so as to directly fix the floorboards 4 to the support members 5 with these nails or threaded nails, as shown in Fig. 8.

However, with this technique, the upper surfaces of the floorboards 4 have a poor appearance since the heads of the nails or threaded nails 7' are exposed thereon, and if the heads of the fasteners such as the nails or threaded nails protrude from the upper surfaces of

the floorboards 4 due to aging, there is a risk of danger to people walking on the floorboards.

Furthermore, if the floorboards 4 once constructed are to be removed, holes formed by the nails or threaded nails would remain on the upper surfaces of the floorboards 4. Therefore, if used floorboards collected from, for example, a demolished house or the like are to be reused, a troublesome process of filling in these holes is necessary.

In light of this, techniques for mounting the floorboards 4 to the support members 5 by using floorboard fixtures 100 and 110 instead of directly driving nails or threaded nails into the upper surfaces of the floorboards 4 have been proposed as shown in Figs. 9(A) and 9(B). In order to allow for mounting using such a floorboard fixture 100 or 110, side surfaces 40 serving as opposite widthwise ends of each floorboard 4 are provided with slits 41 that extend continuously in the longitudinal direction of the floorboard 4. By fixing the floorboard fixture 100 or 110 fitted in the slits 41 to the support members 5, the floorboards 4 can be fixed to the support members 5.

For fixing the floorboards 4 to the support members 5 in this manner, a technique in which a long channel fitting provided with flanges 101 protruding outward from upper edges of an opening is used as the floorboard fixture 100 has been proposed. Specifically, the flanges 101 of the floorboard fixture 100 are respectively inserted into the slits 41 formed in the opposing side surfaces 40 of neighboring floorboards 4, and the threaded nails 7' inserted into nail holes 102 formed in a base plate at a predetermined interval in the longitudinal direction are driven (screwed) into the support members 5, thereby fixing the floorboards 4 to the support members 5 via the floorboard fixture 100 (see Fig. 9(A)). Another proposed technique uses the floorboard fixture 110 which is T-shaped in cross section and has a bridge section 111 and an intermediate segment 112 protruding from the lower surface of the bridge section 111. Specifically, the bridge section 111 of this floorboard fixture 110 is inserted into the slits 41 of the floorboards 4, and the threaded nails 7' inserted into nail holes 113 vertically extending through the intermediate segment 112 are driven (screwed) into the support members 5, thereby fixing the floorboards 4 to the support members 5 (see Fig. 9(B)).

As another proposed example, in the structure of the floorboard fixture 100 described

with reference to Fig. 9(A), engagement claws 103 having serrated edges are formed along the edges of the flanges 101, as shown in Fig. 10, so that when performing the fixing process with the threaded nails 7', the engagement claws 103 engage with inner walls of the slits 41 in the floorboards 4 (Patent Document 1; see Fig. 10). Furthermore, as another proposed example, in the structure of the floorboard fixture 110 described with reference to Fig. 9(B), the floorboard fixture 110 is made to deform as the threaded nails 7' are fastened to the support members 5, whereby increased contact resistance relative to the inner walls of the slits 41 in the floorboards 4 is achieved due to this deformation (Patent Document 2; see Fig. 11).

Document of Related Art

Patent Documents

Patent Document 1: Japanese Unexamined Patent Application Publication No. 2002-146901

Patent Document 2: Japanese Unexamined Patent Application Publication No. 2008-285929

Patent Document 3: Japanese Unexamined Patent Application Publication No. 2008-255601

Patent Document 4: Japanese Unexamined Patent Application Publication No. 2008-031827

Patent Document 5: Japanese Unexamined Patent Application Publication No. 2006-226029

Patent Document 6: Publication of Japanese Registered Utility Model No. 3091481

Disclosure of the Invention

Problem to be Solved by the Invention

In the above-described techniques for fixing the floorboards 4, even if the floorboards 4 are pulled upward away from the support members 5, the floorboards 4 are kept fixed on the support members 5 and cannot be pulled off since the inner walls of the slits 41 formed in the side surfaces 40 of the floorboards 4 are in contact with the flanges 101 or the bridge section 111 of the floorboard fixture 100 or 110 in the fixing techniques described with reference to Figs. 9(A) and 9(B).

Although the fixing techniques using the floorboard fixtures 100 and 110 are advantageous in that the floorboards 4 can be prevented from being pulled upward, a force for

restricting the movement of the floorboards 4 in the longitudinal direction is weak since the floorboards 4 and the floorboard fixture 100 or 110 are not directly connected to each other.

For this reason, when a force that causes the floorboards 4 to move in the longitudinal direction is applied thereto due to, for example, a person walking on the floorboards 4 fixed in this manner, there is a possibility that the floorboards may move in the longitudinal direction and become detached. Therefore, it is necessary to provide crossbars or the like in abutment with opposite longitudinal ends of the floorboards 4 so as to restrict the movement of the floorboards 4.

However, even if the crossbars are provided in this manner to prevent the ends of the floorboards 4 from moving beyond the crossbars, since it is necessary to provide a small clearance between the ends of the floorboards 4 and the crossbars in view of expansion and contraction of the floorboards 4 caused by changes in temperature and/or humidity, the floorboards 4 may move in the longitudinal direction by a distance equivalent to the clearance every time a person walks thereon. If this causes the ends of the floorboards 4 to collide with the aforementioned crossbars, the collision would produce noise, and result in damage or deformation, such as distortion.

In the floorboard fixture 100 discussed in Patent Document 1 shown in Fig. 10, the engagement claws 103 provided on the flanges 101 are brought into engagement with the inner walls of the slits 41 in the floorboards 4 so as to connect neighboring floorboards 4 to each other (paragraph [0055] in Patent Document 1). With the engagement claws 103, the floorboard fixture 100 is given a function similar to a "clamp". By providing these engagement claws 103 and engaging them with the floorboards 4, the floorboards 4 and the floorboard fixture 100 are firmly connected to each other. Consequently, when the floorboard fixture 100 is used, it is assumed that the floorboards 4 can be effectively prevented from moving in the longitudinal direction.

However, a relatively large dimensional change occurs in the floorboards 4, particularly, floorboards 4 formed of synthetic wood, due to a change in temperature or the amount of moisture absorbed. The dimensional change is especially large in the longitudinal

direction of the floorboards 4. For example, the following relates to the case of a 6-meter-long synthetic wood board.

Coefficient of Linear Expansion

$4.4 \times 10^{-5}(\text{°C}^{-1})$ **Measurement Temperature Range:**

-10°C~90°C (JIS K 7197 Compliance)

Expansion Length of 6-meter-long board (ΔL):

$\Delta L=5.28\text{mm}$ (20°C→40°C : in case of Temperature Difference (ΔT)=20°C)

$\Delta L=10.56\text{mm}$ (20°C→60°C : in case of $\Delta T=40^\circ\text{C}$)

(Expansion Length =

Coefficient of Linear Expansion × Board Length × Temperature Difference)

Therefore, if the floorboards 4 and the floorboard fixture 100 are firmly connected to each other by bringing the engagement claws 103 into engagement with the floorboards 4, as in the floorboard fixture 100 in Fig. 10, the dimensional change in the floorboards 4 caused by expansion or contraction cannot be absorbed. Thus, when a large force is applied to the floorboard fixture 100, causing the floorboard fixture 100 to break or deform and the threaded nails 7' to come out, there is a possibility that the floorboards 4 cannot be fixed in position, and that deformation such as warping and distortion may occur in the floorboards 4.

Therefore, in addition to the ability of the floorboard fixture to fix the floorboards 4 while restricting the movement thereof in response to a load applied thereto in normal use, such as when a person walks thereon, it is desirable that the floorboard fixture be able to fix the floorboards 4 while permitting the floorboards 4 to move if an applied force that makes the floorboards 4 move is large enough to break the floorboard fixture, thus such as when a dimensional change occurs in the floorboards 4 due to expansion or contraction of the floorboards 4.

To meet this demand, in the floorboard fixture 110 discussed in Patent Document 2 described above with reference to Fig. 11, the floorboard fixture 110 is formed of a flexible material such as a resin material. Thus, by driving the threaded nails 7', the floorboard fixture 110 becomes deformed so that a pressing force of the bridge section 111 applied to the inner walls of the slits 41 provided in the side surfaces 40 of the floorboards 4 increases, thereby restricting the movement of the floorboards 4 in the longitudinal direction.

Consequently, the floorboards 4 are prevented from moving in response to a force applied in normal use, such as when a person walks on the floorboards 4, but when an extremely large force is applied such as when the dimensions of the floorboards 4 change due to expansion or contraction thereof, the floorboards 4 are permitted to move in accordance with this dimensional change.

However, with regard to the floorboard fixture 110 discussed in Patent Document 2 mentioned above, in order to cause deformation of the floorboard fixture 110, the floorboard fixture 110 is formed into a complicated shape by, for example, forming a cutout in the intermediate segment 112 in a preferred embodiment or forming a thick-walled portion and a thin-walled portion in the bridge section 111.

With regard to the floorboard fixture 100 described with reference to Figs. 9(A) and 10, in order for the heads of the threaded nails 7' to be hidden within the gaps formed between the floorboards 4, the heads of the threaded nails 7' need to have a diameter r that is smaller than or equal to a width W_1 of a groove formed in the floorboard fixture 100. In the floorboard fixture 110 described with reference to Figs. 9(B) and 11, it is necessary to use threaded nails whose heads have a diameter r that is smaller than or equal to a distance (referred to as "joint width" hereinafter) W_2 between the side surfaces 40 of neighboring floorboards 4.

Therefore, if the joint width W_2 of the floorboards 4 is to be made relatively narrow, the diameter r of the heads of the threaded nails 7' to be used is inevitably reduced. For this reason, a tool engagement recess formed in each head may become deformed due to torque from a tool such as a screwdriver, resulting in an inability to fasten the threaded nail 7'.

On the other hand, in the technique for fixing the floorboards 4 described with reference to Figs. 9(B) and 11, if threaded nails with heads having a diameter r larger than the joint width W_2 are purposely used, the heads of the threaded nails 7' would scrape off the side surfaces 40 of the floorboards 4 when fastening the threaded nails 7', resulting in a poor appearance after the construction process. Mending these areas scraped off by the heads of the threaded nails 7' by filling these areas with putty or the like to enhance the appearance

requires many hours of labor.

Even in a case where the threaded nails 7' used have heads with a diameter smaller than the joint width, the side surfaces 40 of the floorboards 4 may similarly be scraped off if the threaded nails 7' are driven slantwise.

The present invention has been made to solve the problems in the related art, and an object thereof is to provide a relatively simple-structured floorboard fixture that has a function for restricting movement of floorboards in the longitudinal direction thereof when an external force generated in normal use such as when a person walks on the floorboards is applied to the floorboards, and that permits the floorboards to move if a force that makes a contact position between the floorboard fixture and the floorboards move in the longitudinal direction is generated due to an extremely strong force, such as when a dimensional change occurs in the floorboards due to expansion and contraction thereof.

In addition to the aforementioned object, another object of the present invention is to provide a floorboard fixture in which a fastener used for fastening the floorboard fixture to a support member has a flat-head with a maximum diameter, and in which, even when a threaded nail with such a large-diameter head is used, the construction process of the floorboard fixture can be performed without causing the head of the threaded nail to scrape off side surfaces of the floorboards in the width direction thereof, while also preventing the head of the threaded nail from protruding from the upper surfaces of the floorboards.

Means for Solving the Problems

Means for solving the problems will be described below using reference numerals used in embodiments of the invention. It is to be noted that these reference numerals are only provided for clarifying the correspondence relationship between the scope of the claims and the embodiments of the invention, but should not be used for limiting the interpretation of the technical scope of the claims of the present invention.

In order to achieve the aforementioned objects, a floorboard fixture 1 according to the present invention is configured to fix multiple (at least two) neighboring floorboards 4,

4, ... (simply referred to as "floorboards 4" hereinafter) onto a support member such as a joist by using a fastener. Each floorboard 4 has slits 41 and 41 that are respectively formed in side surfaces 40 serving as opposite widthwise end surfaces of the floorboard 4 and that extend, preferably continuously, in the longitudinal direction of the floorboard 4.

The floorboard fixture 1 comprises a bridge section 3 having protrusions 22 and a spacer section 2 having an insertion hole 21. The bridge section 3 and the spacer section 2 are formed of a flexible synthetic resin material. The bridge section 3 is inserted into the slits 41 and 41 so as to be bridged between the two neighboring floorboards 4.

The spacer section 2 protrudes toward the upper and lower surfaces of the floorboards from a widthwise intermediate position of the bridge section 3 so as to be interposed between the side surfaces 40 of the two neighboring floorboards 4.

The spacer section 2 is provided with the insertion hole 21 that extends through the spacer section 2 in the aforementioned protruding direction thereof. At least one of side surfaces 23 of the spacer section 2 that are in contact with the opposing side surfaces 40 of the floorboards 4 is provided with a row of protrusions 22 or 22' that are preferably spaced apart by a predetermined distance and that extend in a direction in which the spacer section 2 is orthogonal to the longitudinal direction of the side surfaces 40.

Furthermore, a fastener 7 which is a screw, a nail, or a threaded nail having a head 71 in the shape of so-called inverted conical shape (referred to as "flat-head" in this specification), i.e., a so-called flat-head screw (see Fig. 5(B)) in the embodiments, is inserted into the insertion hole 21 of the spacer section 2. The flat-head 71 has a diameter that is larger than a joint width W_2 determined by the wall thickness of the spacer section 2 but smaller than a width between upper edges of chamfered portions 43 and 43 formed along corner edges of neighboring widthwise ends of upper surfaces of the floorboards 4. The chamfered portions 43 are at least formed at positions of the floorboards where the spacer section 2 is inserted. Moreover, a height h (see Figs. 1(A) and 1(B)) from the lower end of the bridge section 3 to the upper end of the spacer section 2 where the insertion hole 21 is formed is substantially equal to a height H (see Fig. 5) from lower inner walls 41a formed

within the slits 41 of the floorboards 4 to lower edges 43b of the chamfered portions 43.

As mentioned above, the chamfered portions 43 and 43 may at least be provided at positions where the spacer section 2 is inserted (positions where the insertion hole 21 is formed).

In the floorboard fixture 1 having the above-described configuration, the side surfaces 23 of the spacer section 2 provided with the protrusions 22 or 22' may be formed into a so-called serrated shape by forming top portions 22a of the protrusions 22 or 22' into an acute triangular shape in plan view, such that the triangular shape being arranged each of one side thereof is vertically and parallel. Each of consecutively triangular shapes has an acute angle.

Furthermore, if the protrusions 22 or 22' are provided with the acute top portions 22a in this manner, the top portion 22a of each protrusion 22 may be slanted toward one side in the width direction of the protrusion 22 (see an enlarged view in Fig. 2(D)).

Furthermore, a length l (see Fig. 1(A)) from the lower end of the bridge section 3 to the lower end of the spacer section 2 may be slightly smaller than a height L (see Fig. 5) from the lower surfaces of the floorboards 4 to the lower inner walls 41a of the slits 41.

It is preferable that the bridge section 3 and the spacer section 2 protruding in the aforementioned protruding direction from the bridge section 3 be integrally formed into the shape of a cross in cross section by using one of or multiple kinds of resin materials selected from among ABS resin, polypropylene, polyethylene, vinyl chloride, nylon, and fiberglass-reinforced polypropylene with a glass fiber length of 0.5 to 5 mm and a fiberglass content of 10 to 40 parts by weight.

Furthermore, a protruding length of the bridge section 3 may be set such that the bridge section 3 does not interfere with innermost walls of the slits 41 in the floorboards 4 when the spacer section 2 is interposed between the side surfaces 40 of the floorboards 4.

It is preferable that an area where the bridge section 3 comes into contact with inner surfaces of the slits 41 in the floorboards 4 be provided with a plurality of protrusions that form a row.

Effect of the Invention

With the configuration of the present invention described above, the floorboard fixture 1 according to the present invention can achieve the following effects.

By providing the spacer section 2 interposed between the side surfaces 40 of the floorboards 4 not only at the lower side of the bridge section 3 but also at the upper side thereof, the floorboard fixture 1 is formed into the shape of a cross in cross section (see Fig. 1(B)), thereby achieving an increased contact area between the floorboard fixture 1 and the floorboards 4. In addition, by providing the multiple protrusions 22 in the side surfaces 23 of the spacer section 2, the contact resistance between the floorboard fixture 1 and the floorboards 4 can be significantly increased.

Consequently, without having to directly fix the floorboards 4 and the floorboard fixture 1 to each other, the contact resistance between the two can sufficiently prevent the floorboards 4 from moving in the longitudinal direction thereof in response to a force applied thereto in normal use such as when a person walks on the floorboards 4. On the other hand, when an extremely strong force that makes the contact position between the floorboards 4 and the floorboard fixture 1 move is applied such as when a dimensional change occurs in the floorboards 4 due to expansion or contraction thereof, the floorboards 4 are permitted to move. Thus, the floorboard fixture 1 can be prevented from breaking due to expansion or contraction of the floorboards, and the fastener 7 such as a threaded nail can be prevented from coming out, as well as preventing deformation such as warping and distortion, of the floorboards 4.

In the configuration in which the side surfaces 23 of the spacer section 2 are serrated by providing the protrusions 22 or 22' with the acute top portions 22a in plan view of the floorboard fixture 1, the contact resistance between the floorboards 4 and the floorboard fixture 1 can be further increased, thereby more reliably preventing the floorboards 4 from moving in the longitudinal direction in normal use such as when a person walks on the floorboards 4.

In particular, with the top portion 22a of each protrusion 22 being slanted toward one

side in the width direction of the protrusion 22, a floorboard fixture 1 that can more tightly restrict the movement of the floorboards 4 toward one side in the longitudinal direction can be provided.

In the case where the height l from the lower end of the bridge section 3 to the lower end of the spacer section 2 is made slightly smaller than the height L from the lower surfaces of the floorboards 4 to the lower inner walls 41a of the slits 41 in the floorboards, when the floorboard fixture 1 is mounted onto a support member 5 by using the fastener such as a threaded nail, the lower end of the bridge section 3 is firmly pressed against the lower inner walls 41a of the slits in the floorboards, whereby the floorboards can be firmly fixed while still being permitted to move in the longitudinal direction of the floorboards when expansion or contraction occurs.

Relative to the floorboards 4 provided with the chamfered portions 43 that are at least provided at the positions of the floorboards where the spacer section 2 is inserted and that are formed by chamfering the corner edges of the widthwise ends of the upper surfaces of the neighboring floorboards 4 and 4, the height h from the lower end of the bridge section 3 to the upper end of the spacer section 2 where the insertion hole is formed is set substantially equal to the height H from the lower inner walls 41a formed within the slits of the floorboards 4 to the lower edges 43b of the chamfered portions 43. Moreover, in the process for fixing the floorboard fixture 1 to the support member 5, the flat-head screw having the head 71 with a diameter r smaller than the width between upper edges 43a of neighboring chamfered portions 43 and 43 is used for fixing the floorboards to the support member. Thus, the flat-head screw having the flat-head 71 with the diameter r that is larger than the joint width W_2 can be used for the fixing process, thereby reducing problems like damaging a tool engagement recess formed in the head of the fastener 7 such as a threaded nail.

Furthermore, when the floorboards are to be fixed to the support member by using the fastener 7 such as a threaded nail having a flat-head, whose head has a diameter r that is larger than the joint width W_2 , the head 71 of the threaded nail 7 can be fitted into a gap between neighboring chamfered portions 43 and 43, whereby the mounting process can be

performed without causing the head 71 of the fastener 7 to scrape off the side surfaces 40 of the floorboards 4, while also preventing the head 71 of the fastener 7 from protruding from the upper surfaces of the floorboards 4.

In addition, with an inclined side surface 71a of the head 71 of the fastener 7 being in contact with the chamfered portions 43 and 43, the contact resistance relative to the floorboards 4 can be further increased, thereby more reliably preventing the floorboards 4 from moving when in normal use.

Brief Description of the Drawings

The objects and advantages of the present invention will become apparent from a detailed description of preferred embodiments based on the appended drawings using reference numerals that denote respective components.

Fig. 1 illustrates a floorboard fixture according to an embodiment of the present invention, and includes a front view (A), a cross-sectional view (B) taken along line B-B in view (A), a plan view (C), and a perspective view (D);

Fig. 2 illustrates a floorboard fixture according to another embodiment of the present invention, and includes a front view (A), a side view (B), a plan view (C), and a bottom view (D);

Fig. 3 illustrates a modification of the floorboard fixture in Fig. 1, and includes a front view (A) and a bottom view (B);

Fig. 4 illustrates another modification of the floorboard fixture in Fig. 1, and includes a front view (A) and a bottom view (B);

Fig. 5 illustrates the floorboard fixture according to the present invention in use, and includes a diagram (A) showing a threaded nail serving as a fastener before being driven and a diagram (B) showing the threaded nail in a driven state;

Fig. 6 illustrates the floorboard fixture in Fig. 2, and includes diagrams (A) and (B) showing different moving directions of a floorboard and different effects of protrusions, a diagram (C) showing a construction example of floorboard fixtures, and diagrams (D) to (F)

showing the effects of another construction example of floorboard fixtures;

Fig. 7 illustrates how floorboards are normally constructed;

Fig. 8 illustrates how floorboards are fixed (by using nails) in the related art;

Fig. 9 illustrates floorboard fixing techniques in the related art, and includes a diagram (A) showing an example in which a flanged channel fitting is used as a floorboard fixture and a diagram (B) showing an example in which a T-shaped floorboard fixture is used;

Fig. 10 is a perspective view of a floorboard fixture in the related art (corresponding to Fig. 8(a) in Patent Document 1); and

Fig. 11 illustrates a principle of how floorboards are fixed using the floorboard fixture in the related art (corresponding to Fig. 10(B) in Patent Document 2).

Best Mode for Carrying Out the Invention

Embodiments of the present invention will be described below with reference to the appended drawings.

Configuration of Floorboard Fixture

A floorboard fixture 1 according to the present invention is formed into the shape of a cross in cross section (see Fig. 1B) by integrally forming a bridge section 3 and a spacer section 2 which protrudes toward upper and lower surfaces of floorboards from a widthwise intermediate position of the bridge section 3, by using a synthetic resin material having flexibility, for example, ABS resin, polypropylene, polyethylene, vinyl chloride, nylon, or a synthetic resin material having both appropriate rigidity and flexibility, such as fiberglass-reinforced polypropylene with a glass fiber length of 0.5 to 5 mm and a fiberglass content of 10 to 40 parts by weight.

The aforementioned spacer section 2 is provided with an insertion hole 21 extending through the spacer section 2 in the protruding direction thereof. The bridge section 3 is inserted into slits 41 formed in opposing side surfaces 40 of neighboring floorboards 4. In a state where the spacer section 2 is interposed between the side surfaces 40 of the floorboards 4 such that the floorboards are arranged with a fixed joint width W_2 therebetween, a fastener,

in this case, a so-called flat-head screw 7 having a flat-head is inserted into the insertion hole 21 and is driven (screwed) into a support member 5, whereby the floorboard fixture 1 is fixed to the support member 5 such as a joist, and the floorboards 4 are mounted onto the support member 5 via this floorboard fixture 1 (see Figs. 5(A) and 5(B)).

Side surfaces 23 of the spacer section 2 of the floorboard fixture 1, which are interposed between and abut on the side surfaces 40 of the floorboards 4, are each provided with a row of protrusions 22 that are spaced apart by a predetermined distance and that extend in a direction in which the spacer section 2 is orthogonal to the longitudinal direction of the side surfaces 40. In an embodiment shown in Fig. 1, each side surface 23 (23a and 23b; 23c and 23d) of the spacer section 2 is provided with five protrusions 22.

The protrusions 22 may be formed on the entire side surfaces 23 of the spacer section 2 that are in contact with the side surfaces 40 of the floorboards 4 (see Fig. 1) or may be partially formed thereon. For example, the protrusions 22 may be formed in one of the areas (23b and 23d) of the side surfaces 23, located below the bridge section 3 (see Fig. 2), or in both of these areas, or may be formed in one of or both of areas 23a and 23c of the side surfaces 23, located above the bridge section 3. Furthermore, the protrusions 22 may be formed in a freely-chosen combination of the aforementioned areas of the side surfaces.

If the protrusions 22 are to be partially provided on the side surfaces 23 of the spacer section 2, the size of each section is adjusted so that, when the spacer section 2 is interposed between the side surfaces 40 of the floorboards 4, the top portions of the protrusions 22 on the side surface provided with the protrusions 22 abut on the side surface 40 of the corresponding floorboard 4, whereas the flat side surface not provided with the protrusions 22 abuts on the side surface 40 of the corresponding floorboard 4.

In the embodiment shown in Fig. 1, the protrusions 22 each have a rectangular shape in plan view with a flat and relatively wide top portion 22a (see Fig. 1(C)). Alternatively, a larger number of narrower protrusions 22 may be provided, as compared with the configuration in Fig. 1, or the protrusions 22 may each have a triangular shape in plan view with acute top portions 22a such that the side surfaces of the spacer section 2 are entirely

serrated as shown in Fig. 2. As a further alternative, referring to Fig. 3, the relatively wide top portions of the protrusions 22 may be provided with even finer protrusions 22', that is, protrusions 22' with acute top portions in the example shown in the drawing. The protrusions 22 may be formed into various kinds of shapes so long as they extend in the direction in which the spacer section 2 is orthogonal to the longitudinal direction of the floorboards 4 so as to allow for increased contact resistance relative to the side surfaces 40 of the floorboards 4.

In order to achieve such increased contact resistance, the protrusions 22 are preferably formed by providing protrusions 22 or 22' with acute top portions in plan view as shown in Figs. 2 and 3, so that the side surfaces of the spacer section 2 are serrated.

Furthermore, if the protrusions 22 provided on the side surfaces of the spacer section 2 are to have a serrated shape by forming acute top portions 22a, the two sides of each protrusion 22 extending from the bases thereof to the top portion 22a thereof are made as scalene sides as shown in an enlarged view in Fig. 2(D). In other words, the top portions 22a of the protrusions 22 may be slanted toward one side in the width direction of the protrusions 22 by continuously arranging triangles each having one vertical side and an acute-angled side.

The spacer section 2 is provided with the insertion hole 21 that extends through the spacer section 2 in the protruding direction thereof.

In the embodiment in Fig. 1, the insertion hole 21 has a tapered upper-end portion that widens upward and another portion that has the same diameter in the entirety thereof (see Fig. 1(B)). When the floorboards are fixed to the support member by using a threaded nail having a flat-head, that is, a so-called flat-head screw serving as a fastener 7 to be described later, an inclined side surface 71a formed in a head 71 of this flat-head screw is partially fitted into the tapered upper-end portion of the insertion hole 21.

The spacer section 2 is preferably formed such that a height h (see Figs. 1(A) and 1(B)) from the lower end of the bridge section 3 to be described later, to the upper end of the insertion hole 21 in the spacer section 2 is substantially equal to a height H (see Fig. 5(A))

from lower inner walls 41a in the slits 41 of the floorboards 4 to lower edges 43b of chamfered portions 43 formed along opposing edges in the width direction of the upper surfaces of the floorboards. The chamfered portions 43 and 43 are formed along the corner edges of the upper surfaces of neighboring floorboards 4 and 4 at least at positions of the floorboards where the spacer section 2 is fitted.

With this configuration, so long as the fastener has a diameter that is smaller than a width W_3 (see Fig. 5(B)) between upper edges 43a of the chamfered portions 43, the floorboards can be fixed to the support member by using, for example, the threaded nail 7 having the flat-head 71 with a diameter r larger than the joint width W_2 between the side surfaces 40 of the floorboards 4, thereby reducing the occurrence of damage to a tool engagement recess formed in the head of the threaded nail 7 while it is being fastened. In addition, even when the fastening process is performed using such a threaded nail 7, the flat-head 71 of the threaded nail 7 can be fitted in the gap between the chamfered portions 43 and 43 so as to be prevented from protruding from the upper surfaces of the floorboards.

Moreover, since the inclined side surface 71a formed in the head 71 of the threaded nail 7 is attached in a state where it is in contact with the chamfered portions 43 and 43 at least formed at the positions of neighboring floorboards 4 and 4 where the spacer section 2 is inserted (see Fig. 5(B)), the contact resistance between the floorboards 4 and the floorboard fixture 1 can be further increased via the threaded nail 7 due to the contact between the inclined side surface 71a of the threaded nail 7 and the floorboards 4.

In the embodiment shown in Fig. 1, the upper end of the spacer section 2 is entirely formed into a partly-cut-out ellipsoidal arc shape with a bulging center such that the upper side is high at the center and decreases in height toward opposite widthwise ends as shown in a front view in Fig. 1(A). However, the shape of the floorboard fixture 1 is not limited to this. Alternatively, the upper end of the spacer section 2 may have the same height at all positions, or may be formed into, for example, a trapezoidal shape with a high central portion and low opposite widthwise ends. Furthermore, the area corresponding to the tapered upper portion of the insertion hole in Fig. 1(B) may be entirely or partially cut out so that the central

portion is depressed, as shown in Fig. 2(A).

Furthermore, the opposite widthwise ends of the spacer section 2 may be provided with V-shaped deformable portions 24 that extend outward from the end edges of the spacer section 2 as shown in Fig. 4 as an example.

Each deformable portion 24 may have a maximum width that is larger than the wall thickness of the spacer section 2 prior to the mounting process of the floorboard fixture 1, but has deformability to a degree that the deformable portion 24 deforms during the mounting process so as to not restrict the interposed contact of the side surfaces 40 of the floorboards 4 with the side surfaces of the spacer section 2.

The spacer section 2 having the above-described configuration intersects the bridge section 3 at the center of the bridge section 3 in the width direction thereof, which is substantially rectangular in plan view, so that the floorboard fixture 1 has the shape of a cross overall as shown in a cross-sectional view in Fig. 1(B).

The bridge section 3 may have a flat shape with a constant thickness over the entirety thereof, as shown in Fig. 2, so long as it can be fitted into the slits 41 formed in the side surfaces 40 of the floorboards 4. Alternatively, the bridge section 3 may have ribs along the peripheral edges thereof as shown in Fig. 1, or may be provided with protrusions similar to those of the spacer section described above, in areas where the bridge section 3 comes into contact with the inner surfaces of the slits 41 in the floorboards 4.

Although a height l (see Figs. 1(A) and 1(B)) from the lower end of the spacer section 2 to the lower end of the bridge section 3 may be substantially equal to a height L (see Fig. 5(A)) from the lower surfaces of the floorboards 4 to the lower inner walls 41a of the slits 41 in the floorboards, it is preferable that the height l be slightly smaller than the height L .

The maximum thickness of the bridge section 3, that is, the thickness of the peripheral edges of the bridge section 3 in the embodiment in Fig. 1, may be set equal to the width of the slits 41 formed in the side surfaces 40 of the floorboards 4 so that the bridge section 3 is press-fitted into the slits 41, or may be formed smaller than the width of the slits

41 so that the bridge section 3 is loosely fitted into the slits 41.

The bridge section 3 is formed to a size that prevents it from interfering with innermost walls of the slits 41 in the floorboards 4 when the spacer section 2 is interposed between the side surfaces 40 of the floorboards 4.

With the floorboard fixture 1 configured as mentioned above, the floorboards are fixed to the support member 5 by using the fastener 7, and are preferably fixed to the support member 5 by using a threaded nail having a flat-head, that is, a so-called flat-head screw as the fastener 7.

The threaded nail 7 serving as the fastener for the floorboard fixture 1 is formed to be longer than the overall height of the spacer section 2 so as to ensure enough driving depth in the support member 5, and an area excluding the head 71 is formed to a thickness that allows this area to be inserted into the insertion hole 21 formed in the spacer section 2.

Construction Method and Operations

Referring to Figs. 5(A) and 5(B), with regard to the floorboard fixture 1 according to the present invention having the above-described configuration, the bridge section 3 is fitted into the slits 41 formed in the opposing side surfaces 40 of neighboring floorboards 4, and the spacer section 2 is interposed between the side surfaces 40 of the floorboards 4 so that the side surfaces 40 of the floorboards 4 are in contact with the side surfaces 23 of the spacer section 2.

In the case where the floorboard fixture 1 has the deformable portions 24 shown in Fig. 4, the distance between the floorboards 4 is adjusted with the deformation of the deformable portions 24 so that the side surfaces 40 of the floorboards 4 come into pressure contact with the side surfaces 23 of the spacer section 2.

With this process, the joint width W_2 between the floorboards 4 is set to a fixed width based on the wall thickness of the spacer section 2 so that the floorboards 4 can be arranged neatly with the same joint width W_2 .

In this state, the threaded nail 7 inserted in the insertion hole 21 is driven into the support member 5 so that the lower end of the spacer section 2 is pressed onto the support

member 5 and the lower surface of the bridge section 3 is pressed onto the lower inner walls 41a of the slits 41 in the floorboards, whereby the floorboards 4 are fixed onto the support member 5 via the floorboard fixture 1.

In this manner, each floorboard 4 is fixed to multiple locations that are set apart by a predetermined distance, for example, about 450 mm in the longitudinal direction of the floorboard 4 in correspondence with the distance between support members 5 such as joists.

Although the floorboard fixture 1 fixes the floorboards 4 based on the pressure contact between the lower surface of the aforementioned bridge section 3 and the lower inner walls 41a of the slits 41 in the floorboards and the pressure contact between the side surfaces 40 of the floorboards 4 and the side surfaces of the spacer section 2 without being directly fixed to the floorboards 4 with a nail, a threaded nail, or an adhesive, the above-described structure of the floorboard fixture 1 allows for an increased contact area between the side surfaces 40 of the floorboards 4 and the floorboard fixture 1 since the spacer section 2 also exists above the bridge section 3, unlike the T-shaped fixture (see Fig. 9(B)) described in the related art, thereby achieving increased contact resistance.

In addition, since the side surfaces 23 of the spacer section 2 are provided with protrusions that longitudinally extend in the vertical direction of the spacer section, that is, the protrusions 22 extending orthogonally to the longitudinal direction of the slits in the side surfaces of the floorboards 4 in the embodiment in Fig. 5, the contact resistance between the side surfaces 23 of the spacer section 2 and the side surfaces 40 of the floorboards 4 is also increased.

Furthermore, when the floorboards are to be fixed to the support member by using the flat-head screw 7 having the head 71 with a diameter larger than the joint width W_2 as mentioned above, in the fixing process of the floorboard fixture 1, since the inclined side surface 71a provided in the head 71 of the flat-head screw comes into pressure contact with the chamfered portions 43 and 43 formed at the upper corner edges of the floorboards 4 as the flat-head screw 7 is fastened, the movement of the floorboards 4 is restricted also by the contact resistance between the inclined side surface 71a of the head 71 of the flat-head screw

and the floorboards 4.

Furthermore, in the configuration in which the V-shaped deformable portions 24 are provided at the opposite widthwise ends of the spacer section 2, the deformable portions 24 are pressed against the side surfaces 40 of the floorboards 4 due to an elastic restoring force of the deformable portions 24, and the tips of the deformable portions 24 would move together with the floorboards if the floorboards 4 were to move in the longitudinal direction thereof. In that case, since one of the deformable portions 24 would expand outward, the contact resistance relative to the side surfaces 40 of the floorboards 4 is further increased.

Therefore, with the floorboards 4 and the floorboard fixture 1 being in contact with each other, a sufficient fixation force for preventing the floorboards 4 from moving in response to a load or force applied thereto in normal use, such as when a person walks on the floorboards 4, is generated.

On the other hand, if the dimensions of the floorboards 4 change due to, for example, expansion or contraction of the floorboards 4 caused by a change in temperature or humidity, and an extremely strong force that makes the contact position between the floorboards 4 and the floorboard fixture 1 move is thus generated, the floorboards 4 are permitted to move since the floorboards 4 and the floorboard fixture 1 are not directly fastened to each other with a nail, a threaded nail, or an adhesive, as described above.

As a result, even when such a dimensional change in the floorboards 4 occurs due to expansion or contraction, the floorboard fixture 1 can be prevented from breaking and the threaded nail 7 that fixes the floorboard fixture 1 to the support member 5 can be prevented from coming out, as well as preventing deformation such as warping and distortion of the floorboards 4.

Referring to Fig. 2, in the floorboard fixture 1 provided with the protrusions 22 that are arranged such that the acute top portions 22a are slanted toward one side in the width direction of the protrusions 22, assuming that the protrusions 22 of the floorboard fixture 1 are in contact with the side surfaces of the floorboards 4 as shown in Figs. 6(A) and 6(B), a force applied by the floorboard fixture 1 for restricting the movement of the floorboards 4 is

stronger in a case where the floorboards 4 moving in a direction indicated by an arrow A in Fig. 6(A) are to be restricted, as compared with a case where the floorboards 4 moving in a direction indicated by an arrow B in Fig. 6(B) are to be restricted.

Specifically, in the above example, when the floorboards 4 move in the direction of the arrow A, as shown in Fig. 6(A), the top portions 22a of the protrusions 22 of the floorboard fixture 1, which are formed of a flexible material, fixture are pulled by the moving floorboards 4 so as to deform in an outwardly expanding manner, as indicated by arrows a in the drawing. As a result, the contact resistance relative to the side surfaces 40 of the floorboards 4 increases due to the deformation of the protrusions 22.

On the other hand, when the floorboards 4 move in the direction of the arrow B, as shown in Fig. 6(B), the top portions 22a of the protrusions 22 of the floorboard fixture 1, which are formed of a flexible material, are pulled by the movement of floorboards 4 so as to deform in an inwardly contracting manner, as indicated by arrows b in the drawing. As a result, in the case where the protrusions 22 having the above-described shape are provided, the floorboard fixture 1 tightly restricts the movement of the floorboards 4 moving in the direction of the arrow A with a stronger force, as compared with the floorboards 4 moving in the direction of the arrow B.

Accordingly, in the floorboard fixture 1 shown in Fig. 2, the force for restricting the movement of the floorboards 4 varies depending on the direction. Therefore, as shown in Fig. 6(C), for example, floorboard fixtures 1 (1a to 1d) may be alternately arranged facing opposite directions at a predetermined interval in the longitudinal direction of the floorboards 4, so that the floorboard fixtures 1a and 1c tightly restrict the movement of the floorboards 4 when moving in the direction of the arrow (A) in Fig. 6(A), whereas the floorboard fixtures 1b and 1d tightly restrict the movement of the floorboards 4 when moving in the direction of the arrow (B) in Fig. 6(B), thereby preventing the floorboards 4 from moving toward either side in the longitudinal direction.

Furthermore, as shown in Fig. 6(D), for example, in a state where one longitudinal end of each floorboard 4 is butted against a crossbar or the like so as to restrict the movement

thereof, floorboard fixtures 1 (1a and 1b) may be mounted such that a large force for restricting the movement of the floorboard 4 acts in a direction away from the crossbar. With this configuration, the one end of the floorboard 4 is always maintained in abutment with the crossbar.

In a case where the floorboard 4 and the floorboard fixtures 1 (1a and 1b) are mounted as in Fig. 6(D), if by any possibility the floorboard 4 is moved away from the crossbar due to a large unexpected force applied to the floorboard 4, the floorboard 4 can still automatically return to its original position where one end thereof is butted against the crossbar.

Specifically, as shown in Fig. 6(E), if the floorboard 4 in a position where one end thereof has moved away from the crossbar deforms and expands so as to become larger in size, the force for restricting the movement is weaker in the floorboard fixture 1a than in the floorboard fixture 1b. Therefore, the floorboard 4 expands so as to bring the crossbar-side end thereof closer toward the crossbar as indicated by a dashed line in Fig. 6(E).

On the other hand, if the floorboard 4 contracts so as to become smaller in size, because the restricting force is weaker in the floorboard fixture 1b than in the floorboard fixture 1a, the floorboard deforms so as to contract its right end in the drawing, whereby the floorboard 4 can automatically return to its original position (i.e., the position at the time of construction) where the floorboard 4 is butted against the crossbar in accordance with the expansion or contraction of the floorboard 4.

Accordingly, the scope of the following claims is not limited to the equipment, apparatus, machine, or device configured only by specific means disclosed here, or to the steps or method disclosed here. The aforementioned scope of the claims is intended to protect the core or essence of this innovative invention. The present invention apparently has novelty and is practical.

Furthermore, at the time of conception of the present invention, the present invention was not obvious to those skilled in the art in view of the related art or is apparently a pioneering invention within the technical field in view of the revolutionary characteristics of

the invention. In legal terms, the scope of the following claims must be interpreted in an extremely broad way to protect the core of the invention.

Therefore, since the aforementioned objects clarified in the above description are efficiently achieved, and the above configuration permits modifications to some degree without departing from the scope of the invention, all of the contents included in the above description and the appended drawings should be interpreted in an exemplary manner but not in a limited manner. It is to be understood that the scope of the following claims should include all the comprehensive and inherent characteristics of the invention described here, and in linguistic aspects, all other expressions in the scope of the invention belong to the scope of the claims.

The present invention will be described below.

Descriptions of reference numerals

1	Floorboard fixture
2	Spacer section
21	Insertion hole
22, 22'	Protrusions
22a	Top portions
23(23a-23d)	Side surfaces
24	Deformable portions
3	Bridge section
4	Floorboards
40	Side surfaces
41	Slits
41a	Lower inner walls
42	Lower surface (of floorboard)
43(,43)	Chamfered portions
43a	Upper edges (of chamfered portions 43)
43b	Lower edges (of chamfered portions 43)
5	Support members (Joist)
6	Posts
7, 7'	Fastener (Threaded nails, Flat-head screw)
71	Head
71a	Inclined side surface
9	Installation surface
100	Floorboard fixture
101	Flanges
102	Nail holes

103	Engagement claws
110	Floorboard fixing device
111	Bridge section
112	Intermediate segment
113	Nail holes

CLAIMS

1. A floorboard fixture for fixing floorboards, each floorboard having slits that are formed in side surfaces thereof serving as opposite widthwise ends and that extend in a longitudinal direction, wherein

a bridge section and a spacer section are formed of a flexible synthetic resin material, the bridge section being inserted into the slits formed in the side surfaces of two neighboring floorboards so as to be bridged between the two neighboring floorboards, and the spacer section protruding toward upper and lower surfaces of the floorboards from a widthwise intermediate position of the bridge section and being interposed between the side surfaces of the two neighboring floorboards,

the spacer section is provided with an insertion hole that extends through the spacer section in a protruding direction thereof,

side surfaces of the spacer section that are in contact with the side surfaces of the floorboards are provided with a plurality of protrusions that form rows and extend orthogonally to the longitudinal direction of the side surfaces of the floorboards,

a fastener having a flat-head is inserted into the insertion hole of the spacer section, the flat-head having a diameter that is larger than a joint width determined by a wall thickness of the spacer section but smaller than a width between upper edges of chamfered portions formed along corner edges of neighboring widthwise ends of the upper surfaces of the floorboards, the chamfered portions being at least formed at positions of the floorboards where the spacer section is inserted, and

a height from a lower end of the bridge section to an upper end of the spacer section where the insertion hole is formed is substantially equal to a height from lower inner walls formed within the slits of the floorboards to lower edges of the chamfered portions.

2. The floorboard fixture according to Claim 1, wherein the side surfaces of the spacer section are serrated by forming top portions of the protrusions into a triangular shape in plan view, such that the triangular shape being arranged each of one side thereof is vertically and

parrallel, and each of consecutively triangular shapes has an acute angle.

3. The floorboard fixture according to Claim 2, wherein the top portion of each protrusion is slanted toward one side in a width direction of the protrusion.

4. The floorboard fixture according to Claim 1, wherein a length from the lower end of the bridge section to a lower end of the spacer section is slightly smaller than a height from the lower surfaces of the floorboards to the lower inner walls of the slits.

5. The floorboard fixture according to Claim 1, wherein the fastener inserted into the insertion hole is a threaded nail, a nail, or a screw having a flat-head.

6. The floorboard fixture according to Claim 1, wherein the bridge section and the spacer section are integrally formed into a shape of a cross in cross section by using a single kind of resin material or a mixture of multiple kinds of resin materials selected from among ABS resin, polypropylene, polyethylene, vinyl chloride, nylon, and fiberglass-reinforced polypropylene with a glass fiber length of 0.5 to 5 mm and a fiberglass content of 10 to 40 parts by weight.

7. The floorboard fixture according to Claim 1, wherein a protruding length of the bridge section is set such that the bridge section does not interfere with innermost walls of the slits when the spacer section is interposed between the side surfaces of the floorboards.

8. The floorboard fixture according to Claim 1, wherein an area where the bridge section comes into contact with inner surfaces of the slits in the floorboards is provided with a plurality of protrusions that form a row.

FIG. 1

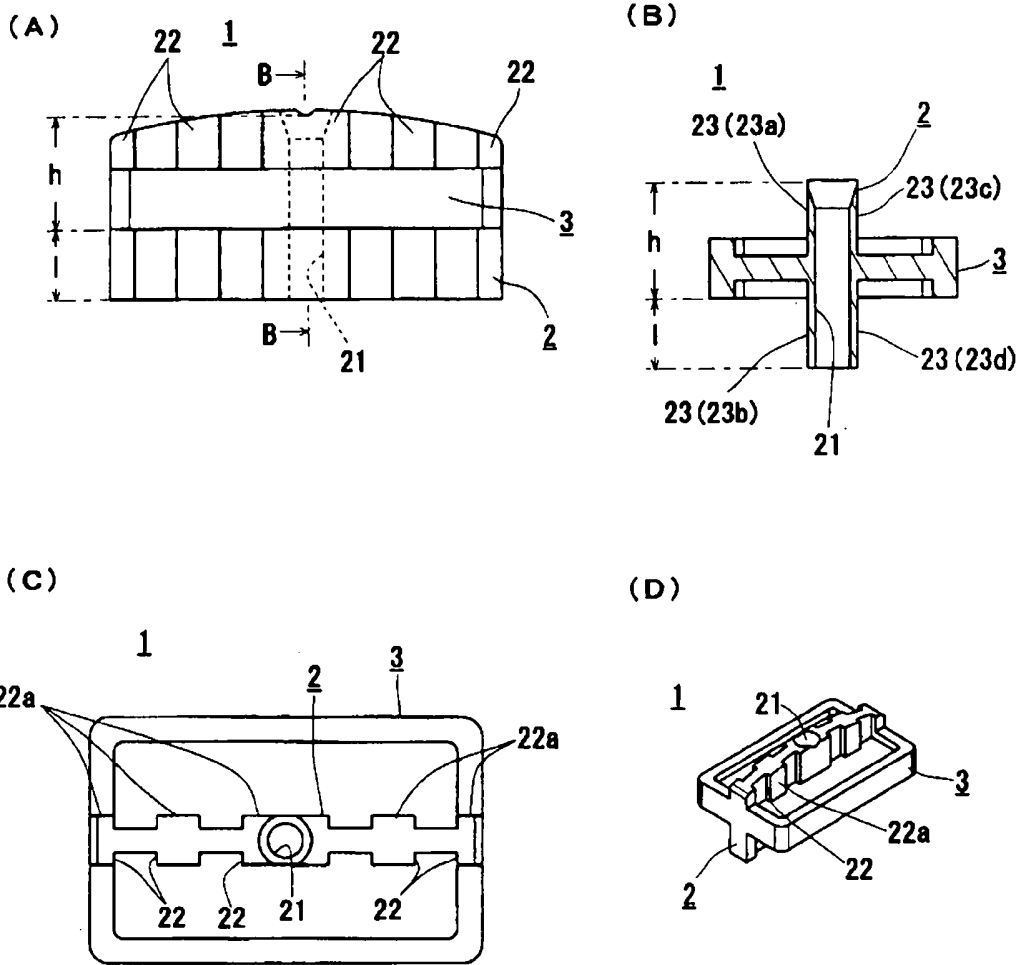
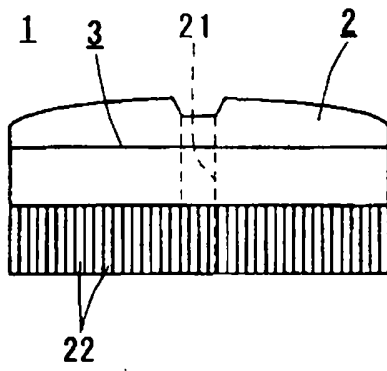
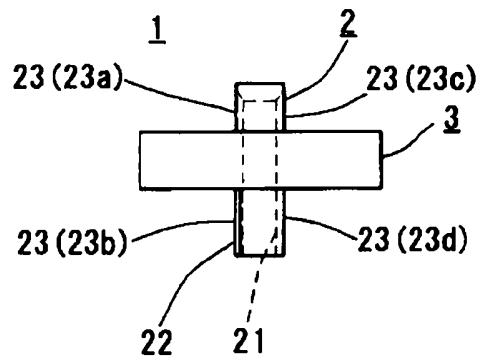

FIG. 2

(A)



(B)



(C)

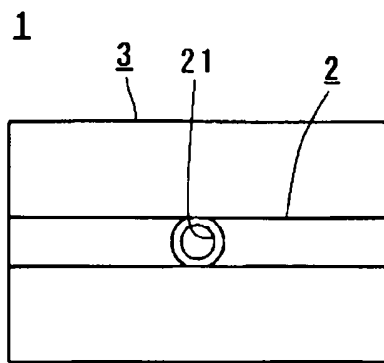

(D)

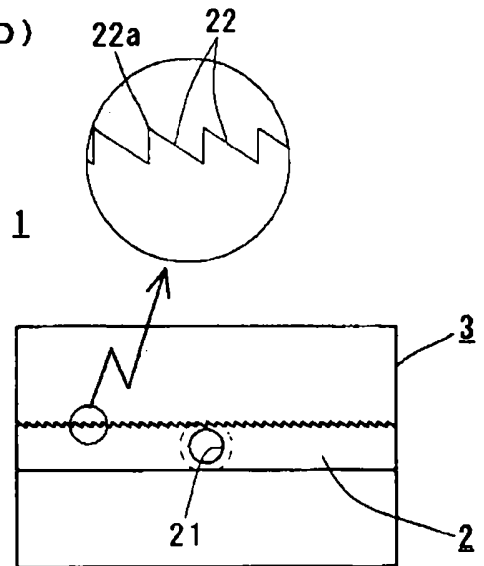
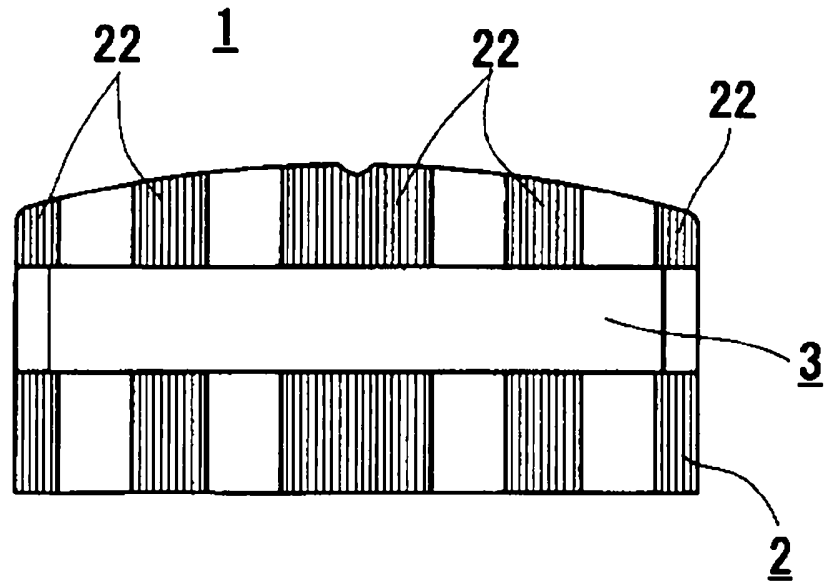

FIG. 3

(A)



(B)

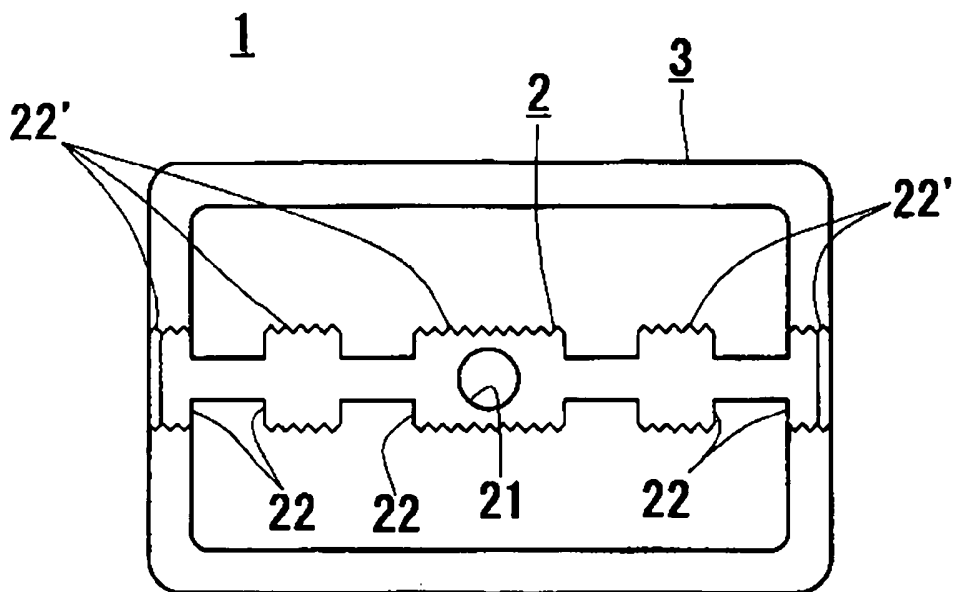

FIG. 4

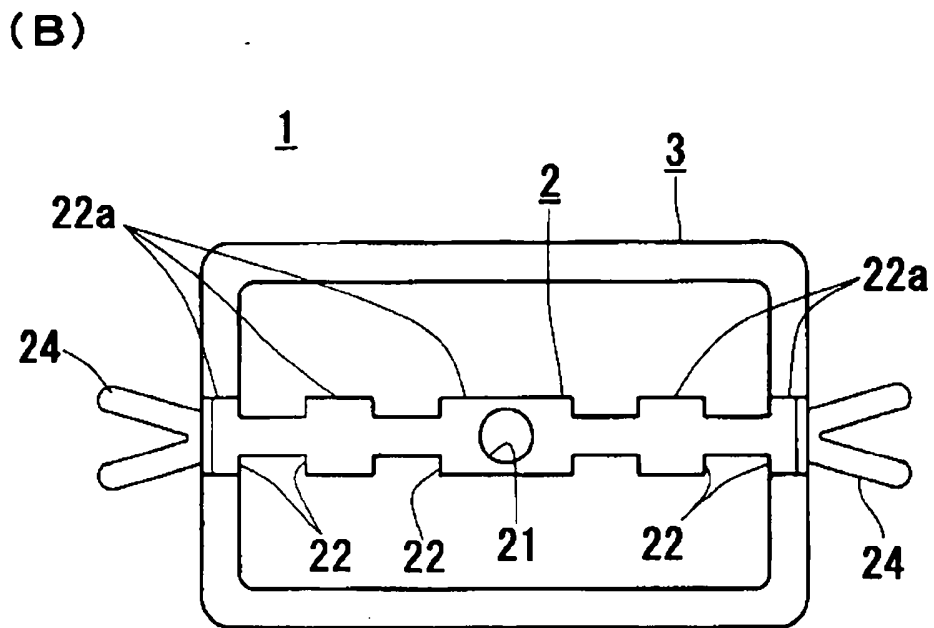
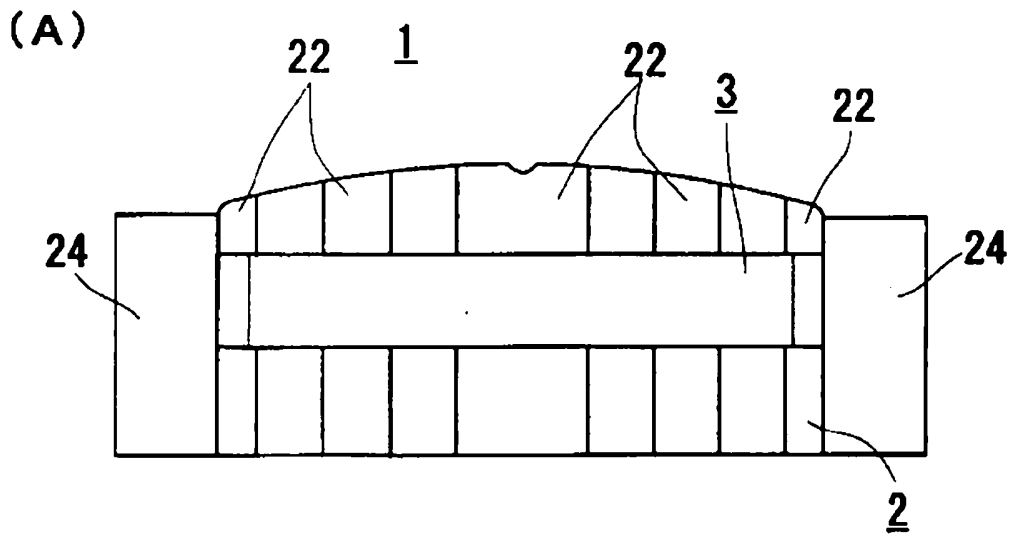

FIG. 5

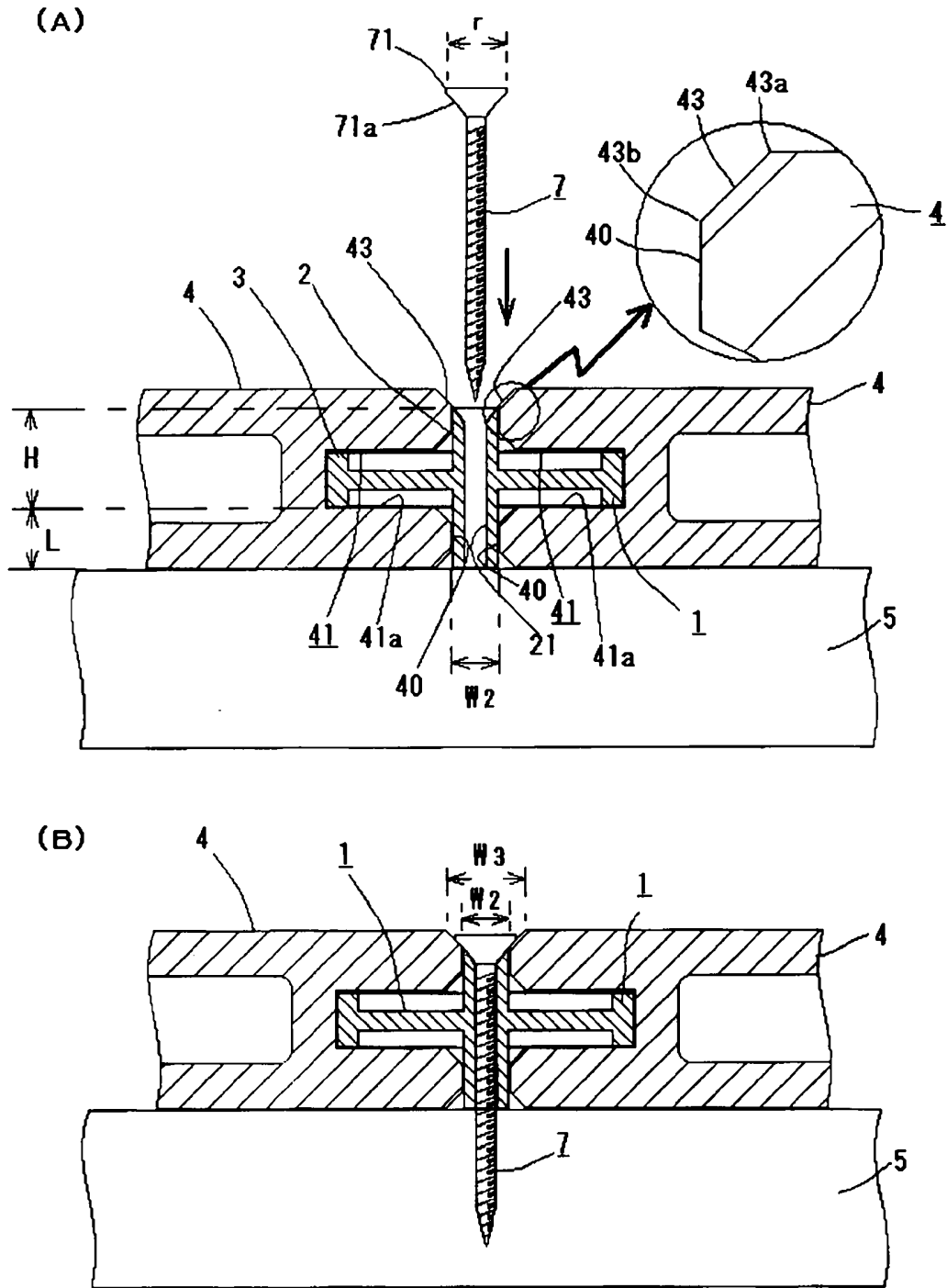
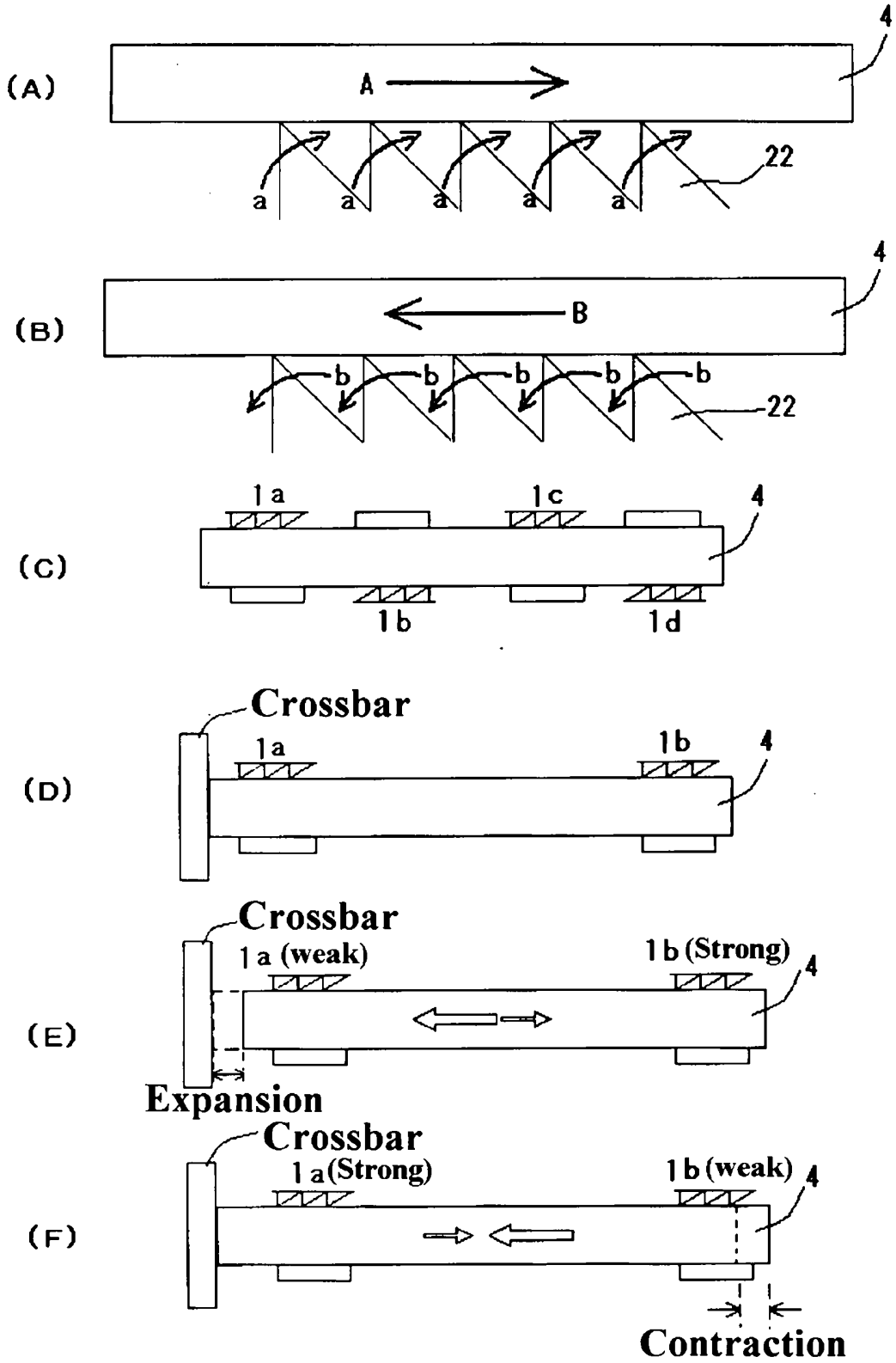

FIG. 6



7 / 10

FIG. 7

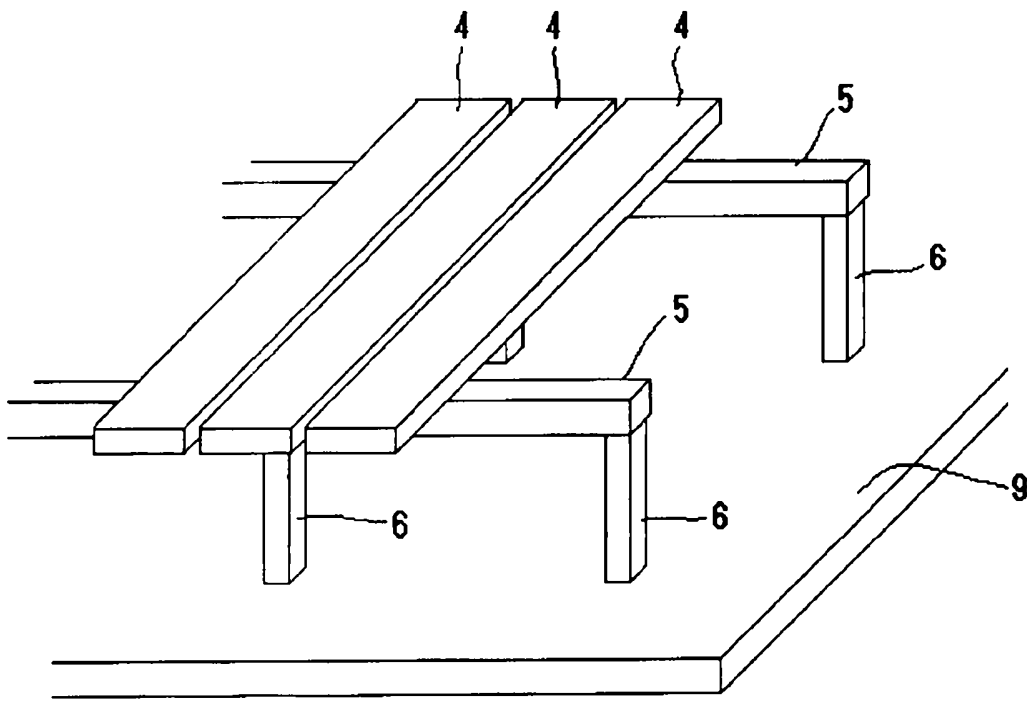

FIG. 8

Related Art

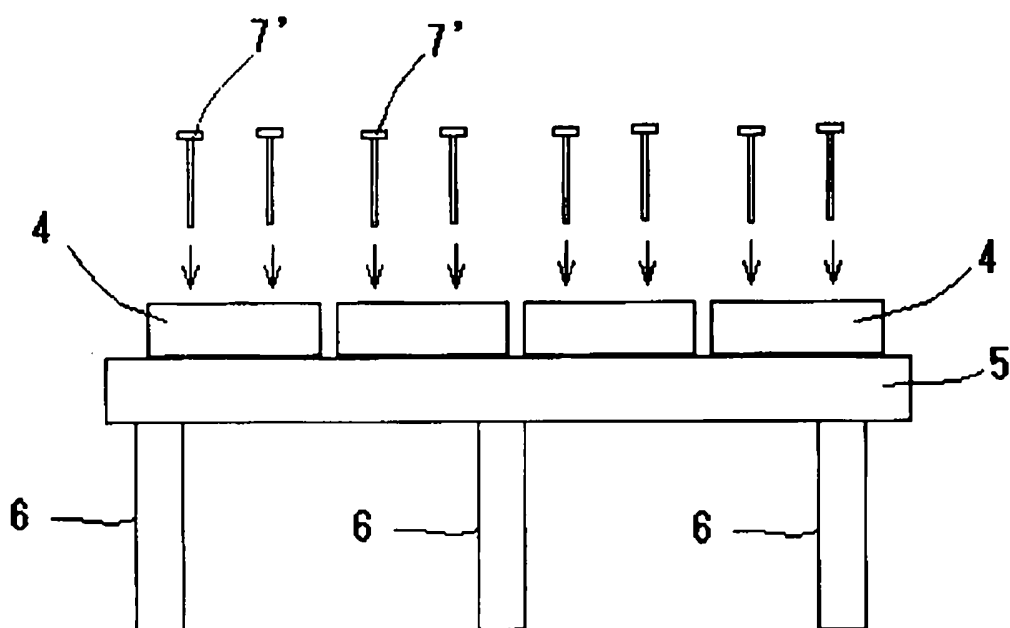

FIG. 9

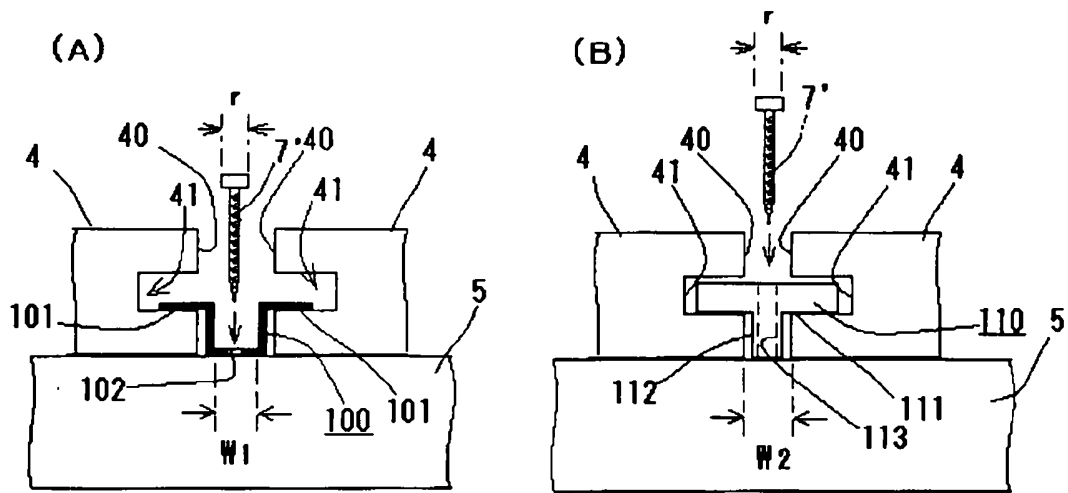

FIG. 10

Related Art

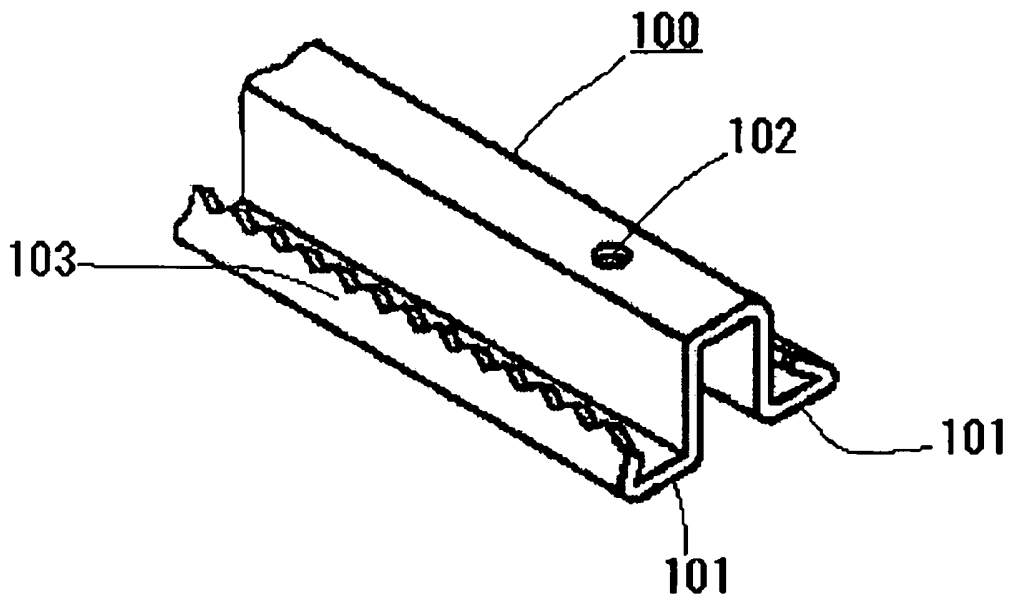

FIG. 11

Related Art

