



US007261151B2

(12) **United States Patent**  
**Memory et al.**

(10) **Patent No.:** **US 7,261,151 B2**  
(45) **Date of Patent:** **Aug. 28, 2007**

(54) **SUCTION LINE HEAT EXCHANGER FOR CO<sub>2</sub> COOLING SYSTEM**

3,421,339 A 1/1969 Volk et al.  
3,540,230 A 11/1970 Evans  
3,638,446 A 2/1972 Palmer

(75) Inventors: **Stephen B. Memory**, Kenosha, WI (US); **Jianmin Yin**, Kenosha, WI (US)

(73) Assignee: **Modine Manufacturing Company**, Racine, WI (US)

(Continued)

FOREIGN PATENT DOCUMENTS

(\*) Notice: Subject to any disclaimer, the term of this patent is extended or adjusted under 35 U.S.C. 154(b) by 242 days.

DE 33 19 733 A1 12/1983

(21) Appl. No.: **10/718,274**

(Continued)

(22) Filed: **Nov. 20, 2003**

OTHER PUBLICATIONS

(65) **Prior Publication Data**

International Search Report dated May 24, 2005.

US 2005/0109486 A1 May 26, 2005

(Continued)

(51) **Int. Cl.**  
**G05D 16/00** (2006.01)  
**F25B 13/00** (2006.01)

*Primary Examiner*—Ljiljana Ciric  
(74) *Attorney, Agent, or Firm*—Michael Best & Friedrich

(52) **U.S. Cl.** ..... **165/284**; 165/281; 165/62; 165/103; 62/228.5

(57) **ABSTRACT**

(58) **Field of Classification Search** ..... 165/281, 165/282, 283, 284, 62, 96, 103; 62/513, 62/228.5

A heat exchanger including a suction line for gaseous or two phase refrigerant output from an evaporator and a capillary tube carrying cooled refrigerant to the evaporator. The suction line includes first and second substantially parallel straight cylindrical portions connected in series, with first and second portions of the capillary tube in series and helically wound around the suction line second and first portions, respectively. A valve for bypassing the capillary tube is responsive to a selected pressure differential between the capillary tube inlet and outlet. A U-shaped portion or accumulator connect the suction line first and second portions. An accumulator alternately is between the evaporator and the suction line portion wound by the capillary tube, with a phase separation chamber connected to an accumulator by a vertical pipe. The accumulator includes a discharge opening to return the oil to the system.

See application file for complete search history.

(56) **References Cited**

U.S. PATENT DOCUMENTS

- 1,408,453 A 3/1922 Goosmann
- 2,467,078 A 4/1949 Cahenzli, Jr.
- 2,482,171 A 9/1949 Gygax
- 2,520,045 A 8/1950 McGrath
- 2,530,648 A 11/1950 Cahenzli, Jr.
- 2,675,683 A 4/1954 McGrath et al.
- 2,901,894 A 9/1959 Zearfoss, Jr.
- 2,990,698 A 7/1961 Crotser
- 3,128,607 A 4/1964 Kyle
- 3,163,998 A 1/1965 Wile et al.
- 3,246,482 A 4/1966 Harnish
- 3,381,487 A 5/1968 Harnish

**7 Claims, 4 Drawing Sheets**

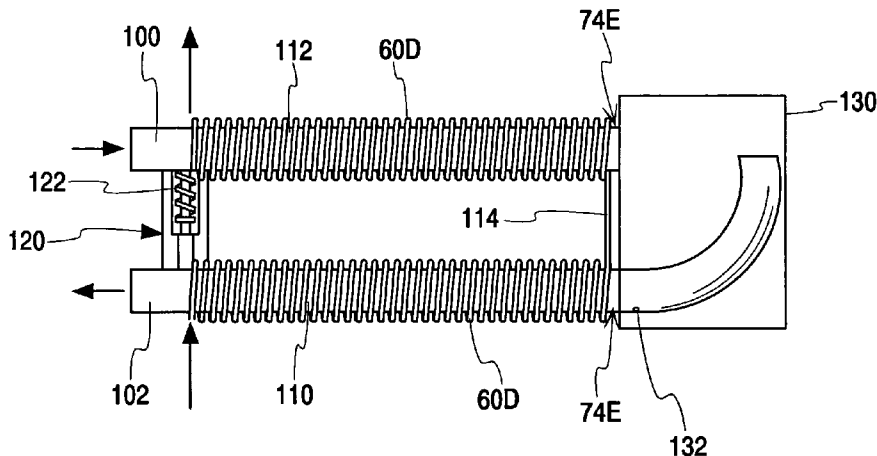

# US 7,261,151 B2

Page 2

## U.S. PATENT DOCUMENTS

3,872,682 A 3/1975 Shook  
3,955,375 A 5/1976 Schumacher  
3,978,685 A 9/1976 Taylor  
3,995,441 A \* 12/1976 McMillin ..... 62/177  
5,245,836 A 9/1993 Lorentzen et al.  
5,367,887 A \* 11/1994 Byrd et al. .... 62/266  
5,531,080 A 7/1996 Hirahara et al.  
5,685,160 A 11/1997 Abersfelder et al.  
6,073,454 A 6/2000 Spauschus et al.  
6,112,547 A 9/2000 Spauschus et al.  
6,178,761 B1 1/2001 Karl  
6,185,957 B1 \* 2/2001 Voss et al. .... 62/513  
6,233,969 B1 5/2001 Yamauchi et al.  
6,298,687 B1 10/2001 Dienhart et al.  
6,343,486 B1 2/2002 Mizukami  
6,460,358 B1 10/2002 Hebert  
6,848,268 B1 \* 2/2005 Memory et al. .... 62/228.5

6,901,763 B2 \* 6/2005 Memory et al. .... 62/513  
6,959,758 B2 \* 11/2005 Hughes et al. .... 165/165  
7,013,672 B2 \* 3/2006 Matsumoto et al. .... 62/513  
2003/0102113 A1 \* 6/2003 Memory et al. .... 165/152

## FOREIGN PATENT DOCUMENTS

JP 4-371777 12/1992  
JP 2000-18775 1/2000  
JP 2001-82814 3/2001  
JP 2002-349979 12/2002  
JP 2004-12127 1/2004

## OTHER PUBLICATIONS

Written Opinion of the International Searching Authority dated May 24, 2005.

\* cited by examiner

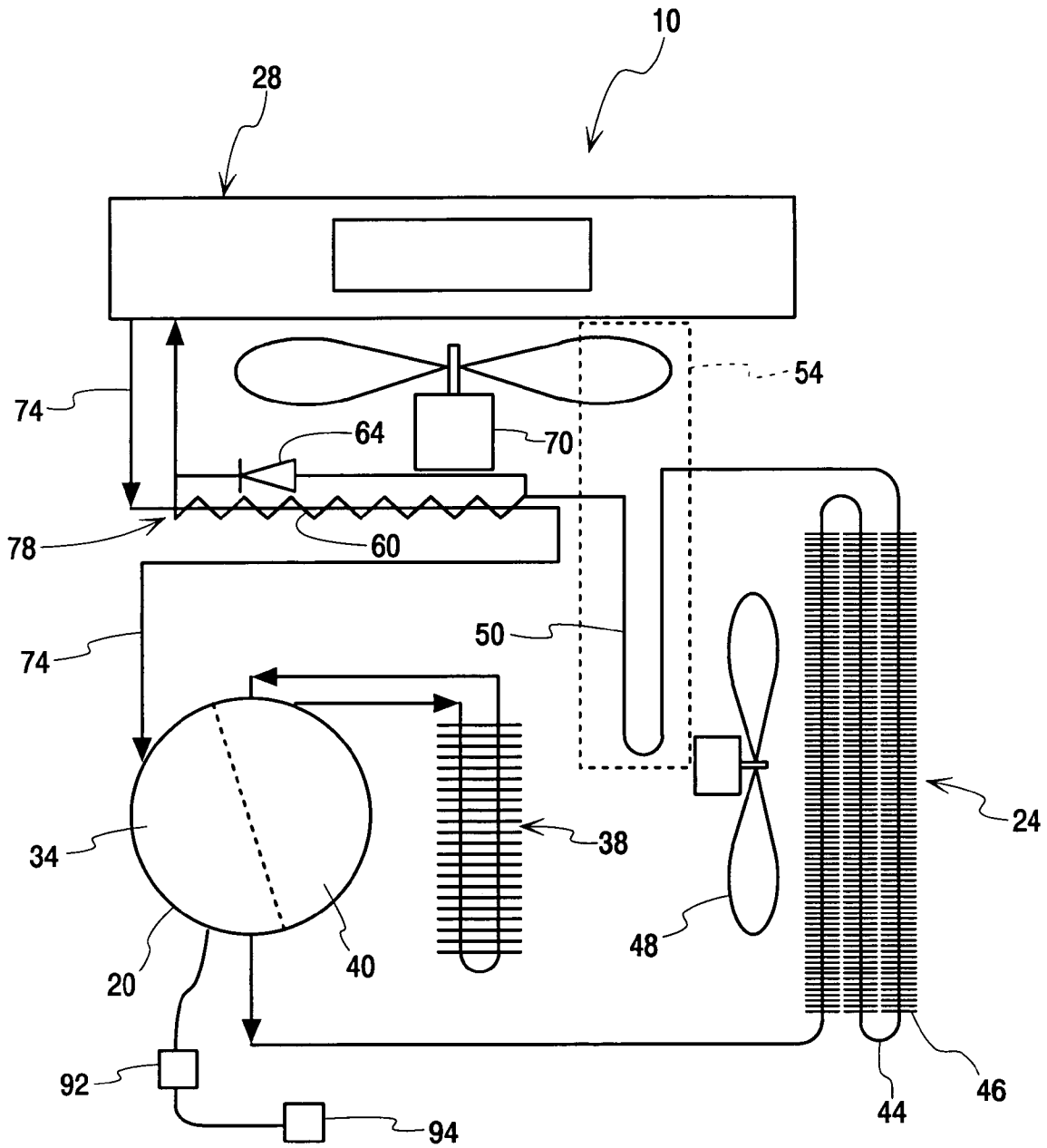

Fig. 1

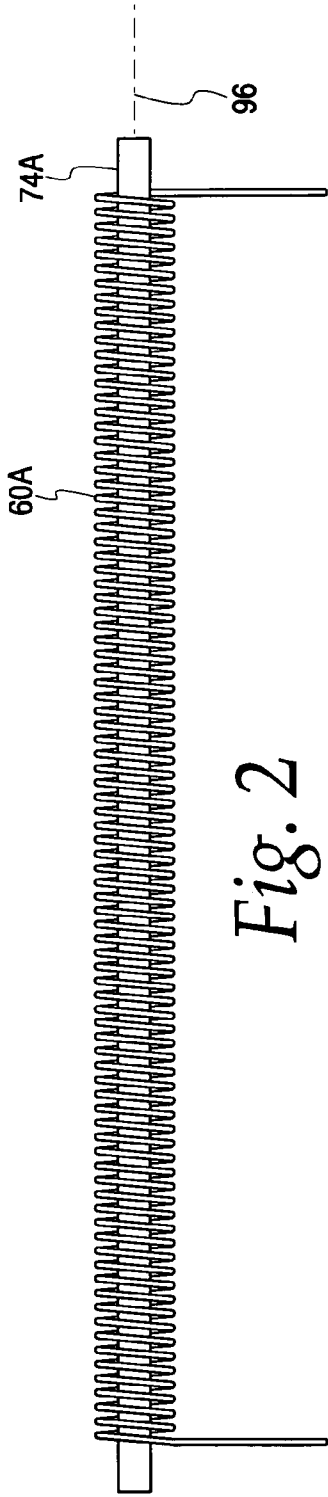

Fig. 2

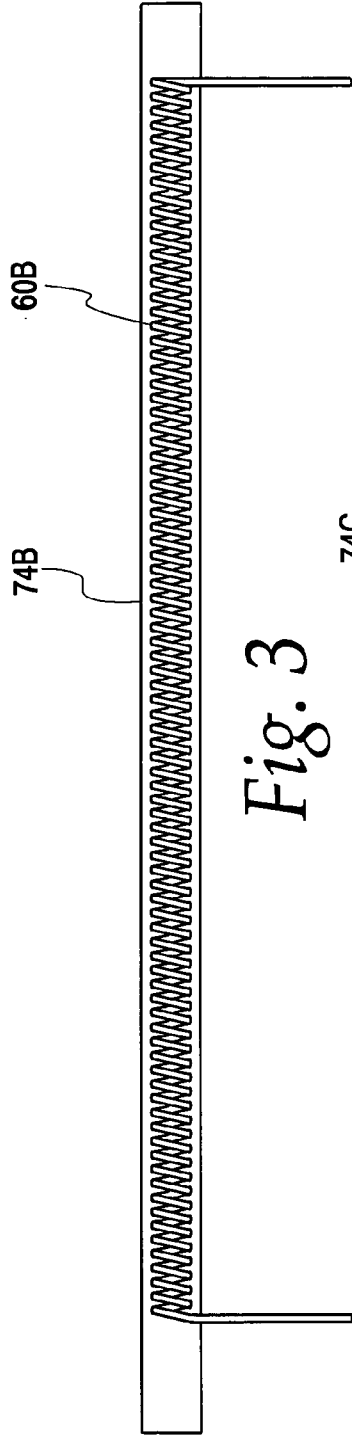

Fig. 3

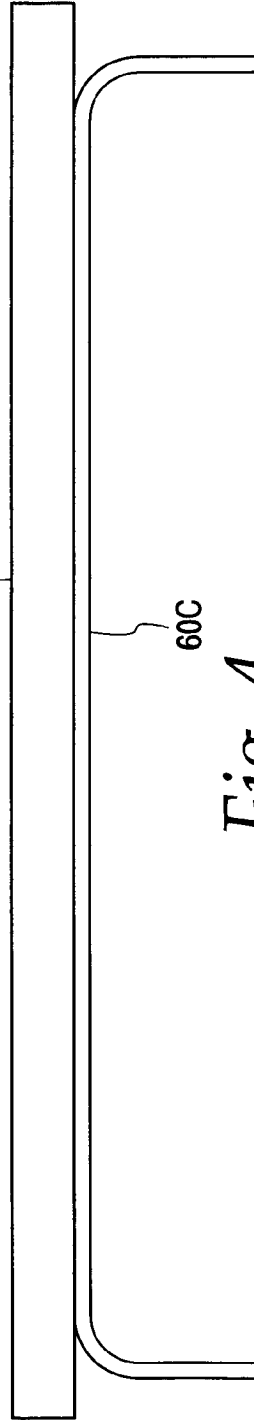

Fig. 4

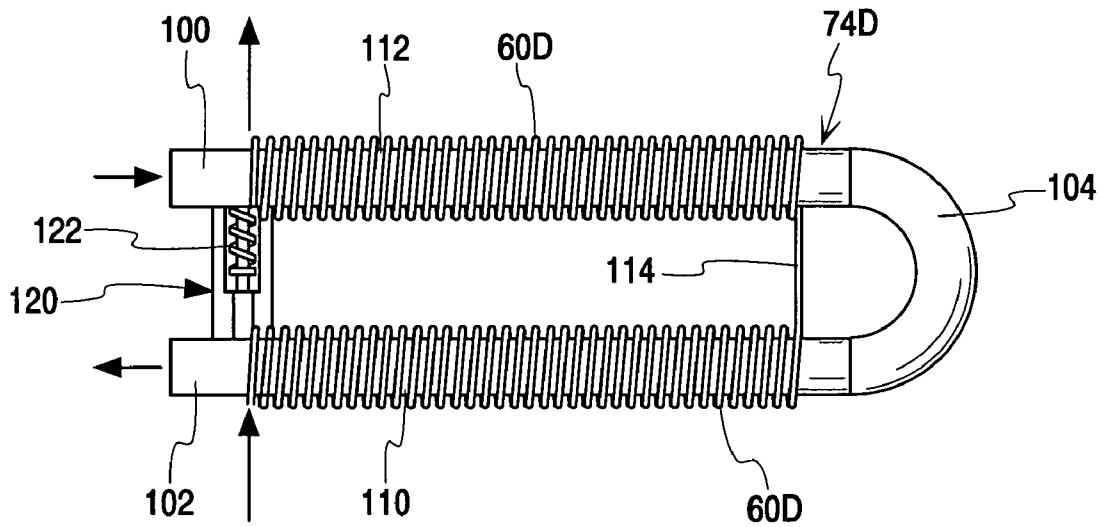

Fig. 5

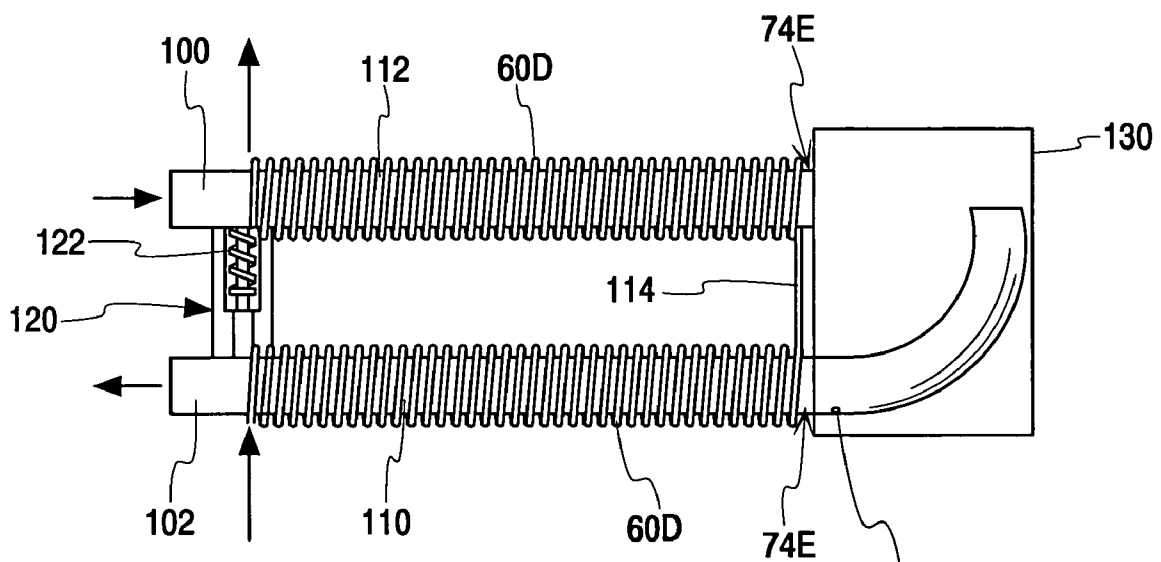

Fig. 6

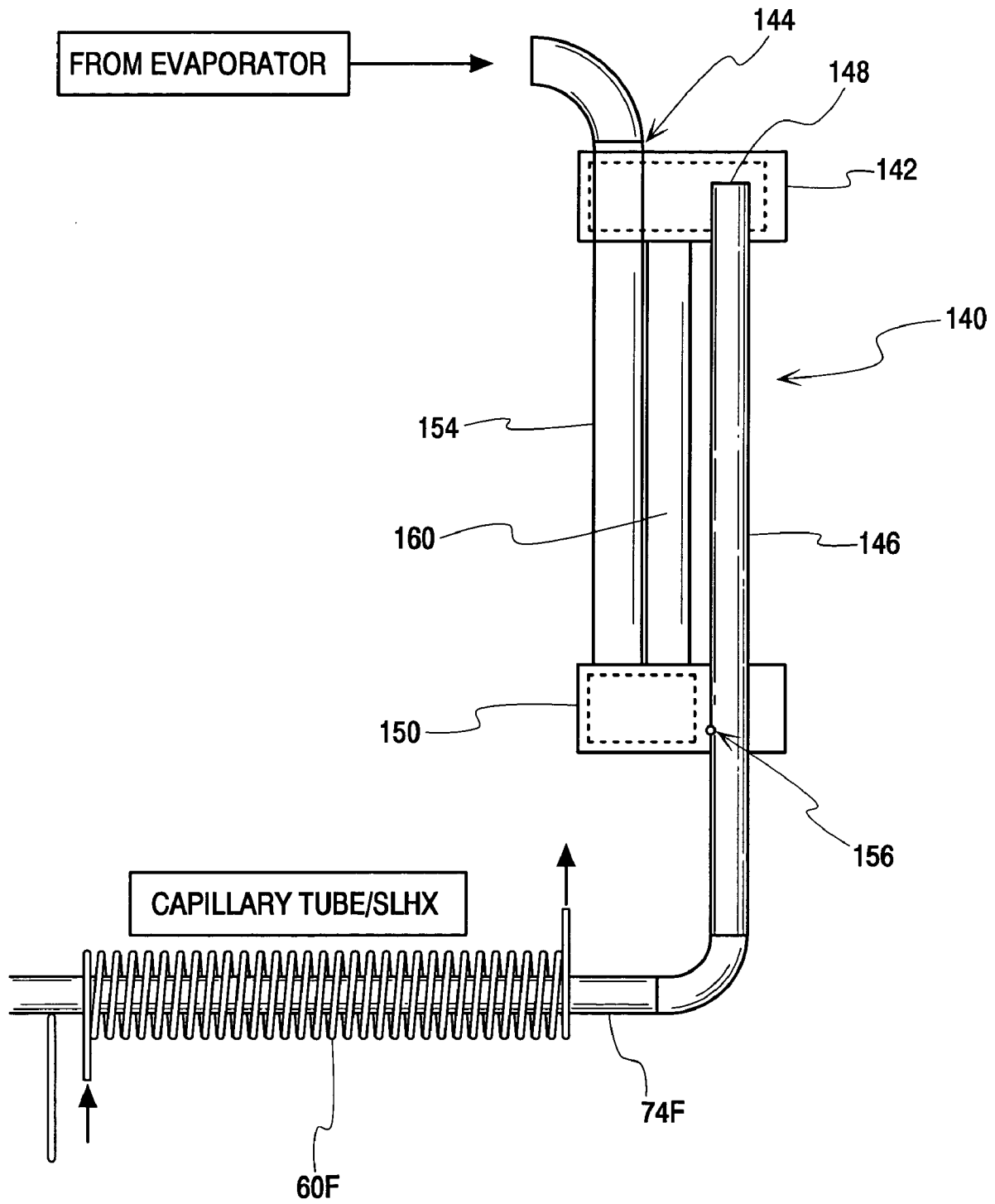

Fig. 7

1

## SUCTION LINE HEAT EXCHANGER FOR CO<sub>2</sub> COOLING SYSTEM

### CROSS REFERENCE TO RELATED APPLICATION(S)

Not applicable.

### STATEMENT REGARDING FEDERALLY SPONSORED RESEARCH OR DEVELOPMENT

Not applicable.

### REFERENCE TO A MICROFICHE APPENDIX

Not applicable.

### TECHNICAL FIELD

The present invention relates to heat exchangers, and more particularly to suction line heat exchangers for transcritical cooling systems.

### BACKGROUND OF THE INVENTION AND TECHNICAL PROBLEMS POSED BY THE PRIOR ART

Transcritical cooling systems are known in the art. Such systems typically cyclically compress, cool and evaporate a refrigerant, flowing through a first side of an evaporator, where heat is absorbed during evaporation from a second side of the evaporator to cool fluid on the second side. Such systems may be used, for example, for automotive air conditioning.

In an exemplary system, there is a compressor, a condenser, and an evaporator, with a counterflow heat exchanger for exchanging heat between the fluid passing from the condenser to the evaporator and the fluid passing from the evaporator to the compressor. As shown in U.S. Pat. No. 5,245,836, an integrated storage segment (liquid separator/receiver) is required in the closed fluid circuit between the evaporator and the compressor. U.S. Pat. Nos. 2,467,078, 2,530,648 and 2,990,698 illustrate combinations of heat exchanger, accumulator and metering device which may be used with such cooling systems.

The present invention is directed toward improving such transcritical cooling systems.

### SUMMARY OF THE INVENTION

In one aspect of the present invention, a heat exchanger for a cooling system having a refrigerant evaporator is provided, including a suction line for gaseous refrigerant output from the evaporator and a capillary tube adapted to carry cooled refrigerant to the evaporator. The suction line includes first and second substantially parallel straight cylindrical portions connected in series whereby the second straight cylindrical portion receives gaseous refrigerant from the first straight cylindrical portion. The capillary tube includes first and second helically wound portions connected in series whereby the second helically wound portion receives cooled refrigerant from the first helically wound portion. The first helically wound portion is wrapped around the suction line second straight cylindrical portion and the second helically wound portion is wrapped around the suction line first straight cylindrical portion.

2

In an advantageous form of this aspect of the invention, a bypass safety valve is provided between an inlet to the first helically wound portion of the capillary tube and an outlet from the second helically wound portion of the capillary tube. The valve opens responsive to a selected pressure differential between the inlet to the first helically wound portion of the capillary tube and the outlet from the second helically wound portion of the capillary tube.

In another advantageous form of this aspect of the invention, the suction line includes a U-shaped portion connecting the first and second cylindrical portions of the suction line.

In yet another advantageous form of this aspect of the invention, an accumulator is provided between the first and second cylindrical portions of the suction line.

In still further advantageous forms, the refrigerant is CO<sub>2</sub> and the capillary tube is an expansion device for the cooled CO<sub>2</sub> refrigerant, and/or the cooling system is transcritical.

In another aspect of the present invention, a heat exchanger for a cooling system having a refrigerant evaporator is provided, including a suction line for refrigerant output from the evaporator and a capillary tube adapted to carry cooled refrigerant to the evaporator. The suction line includes a straight portion substantially cylindrical about an axis, and an accumulator between the evaporator and the suction line straight portion. The capillary tube includes a portion helically wound around a central axis generally coinciding with the suction line straight portion axis. The accumulator includes a phase separation chamber having an input for refrigerant from the evaporator and an outlet for gaseous refrigerant from which oil and liquid droplets have been separated in the phase separation chamber, an accumulator including a discharge opening for discharging oil to return the oil to the system, and a vertical pipe between the phase separation chamber and the accumulator.

In an advantageous form of this aspect of the invention, a second vertical pipe is provided between the phase separation chamber and the accumulator, with the second vertical pipe adapted to hold a selected volume of refrigerant charge.

In other advantageous forms of this aspect of the invention, the cooling system is transcritical, and/or the refrigerant is carbon dioxide.

### BRIEF DESCRIPTION OF THE DRAWINGS

FIG. 1 is a schematic view of a cooling system embodying an aspect of the present invention;

FIG. 2 illustrates a first embodiment of a suction line heat exchanger which may be used with the present invention;

FIG. 3 illustrates a second embodiment of a suction line heat exchanger which may be used with the present invention;

FIG. 4 illustrates a third embodiment of a suction line heat exchanger which may be used with the present invention;

FIG. 5 illustrates a suction line heat exchanger embodying another aspect of the present invention;

FIG. 6 illustrates a modified suction line heat exchanger with an accumulator; and

FIG. 7 illustrates an alternative suction line heat exchanger and accumulator.

### DETAILED DESCRIPTION OF THE INVENTION

An exemplary embodiment of a cooling system 10 embodying the present invention is shown in FIG. 1, including a compressor 20, a counterflow gas cooler 24, and an evaporator 28.

In the advantageous embodiment illustrated, the compressor **20** is a two-stage compressor, in which gaseous refrigerant is input into the first stage **34** of the compressor **20**, which compresses the refrigerant. The compressed refrigerant from the compressor first stage **34** is output to an optional inter-cooler **38**, where it may be suitably cooled, after which it is input to the second stage **40** of the compressor **20**, which further compresses the gaseous refrigerant. The first and second stages **34**, **40** of the compressor **20** are represented schematically in FIG. 1.

While carbon dioxide (CO<sub>2</sub>) may be used as the refrigerant according to one advantageous aspect of the invention, particularly in transcritical cooling systems, it should also be appreciated that still other working fluids could be used with the present invention including, for example, other refrigerants.

The refrigerant compressed by the second stage **40** of the compressor **20** is discharged to the gas cooler **24**. The gas cooler **24** may be in any suitable form for cooling and/or condensing the gas which passes through the tubes of the cooler **24**. For example, a gas cooler **24** having a serpentine tube **44** with fins **46** between runs of the tube **44** is schematically shown in FIG. 1 for illustration purposes. The gaseous refrigerant in the tube **44** is cooled via heat transfer with environmental air which may be advantageously blown over the air-side of the tubes **44** and fins **46**, as by the schematically illustrated fan **48**. However, it should be understood that single pass or multipass condenser structures having round tubes and plate fins, or having microchannel tubes and serpentine fins, may also be advantageously used with the present invention, as well as any other heat exchanger suitable to the environment in which the system **10** is to be used for cooling gaseous refrigerant discharged from the compressor.

The inter-cooler **38** may be advantageously integrated with the gas cooler **24**, albeit with separate refrigerant paths, whereby the refrigerant may be cooled via air blown (as by fan **48**) over tubes containing refrigerant discharged from the compressor first stage **34** (i.e., tubes in the inter-cooler **38**) and refrigerant discharged from the compressor second stage **38** (i.e., tubes **44**). In an advantageous configuration, the inter-cooler **38** and gas cooler **24** may be assembled together with microchannel tubes and serpentine fins.

The cooled gaseous refrigerant discharged from the gas cooler **24** passes through a refrigerant tube **50** in a water collecting pan/cooler **54**, for further cooling of the refrigerant leaving the gas cooler **24** as further described hereafter.

The refrigerant tube **50** is split into two paths after the water collecting pan **54**, with one path consisting of a capillary tube **60** and the other having an inter-bleeding valve **64**. The capillary tube **60** has a small diameter so as to throttle the refrigerant, causing the refrigerant to expand to a two phase state at the outlet of the capillary tube **60** while also controlling the flow rate of refrigerant through the system **10**. Further, as described hereafter, the refrigerant is also cooled in the capillary tube **60**.

The inter-bleeding valve **64** is adapted to open at a pressure which is above the normal operating pressure of the system **10**, so as to allow for bypassing around the capillary tube **60** during extremely high pressures, such as pressure spikes which can occur during start up of the system **10**.

The two phase refrigerant discharged from the capillary tube **60** then passes to the evaporator **28**, where the liquid refrigerant is suitably evaporated to a gaseous state. For example, as illustrated, warmer environmental air may be blown over the evaporator **28** by a fan **70**, whereby heat from

the air is absorbed by the cooler refrigerant in the evaporator **28**, causing the refrigerant to evaporate into a gaseous state.

Condensation of water in the warmer environmental air on the evaporator **28** is collected in the water collecting pan **54**, which water serves to cool the refrigerant passing through the refrigerant tube **50** submersed in the water in the pan **54** as previously noted.

The gaseous refrigerant is discharged from the evaporator **28** through a suction line tube **74** which is connected to the input of the first stage **34** of the compressor **20**, with the refrigerant then cycling through the system **10** again as described above.

Further, the suction line tube **74** cooperates with the capillary tube **60** so as to form a suction line heat exchanger **78**. Specifically, in the configuration illustrated in FIG. 1, the capillary tube **60** is helically wound around the suction line tube **74** whereby heat is advantageously exchanged between refrigerant in the tubes **60**, **74**.

A single controller **92** may be advantageously used to control the system **10** by simply turning the compressor **20** on and/or off responsive to a sensed condition. For example, a suitable sensor **94** such as a simple thermocouple may be provided to sense ambient air temperature, with the controller **92** responsive to the sensed temperature to turn on the compressor **20**, (and fans **48**, **70**) when the temperature rises above a selected level. The sensor **94** may alternatively be used to sense different conditions, such as temperature or pressure in the suction line tube **74**.

FIGS. 2-7 variously further illustrate advantageous suction line heat exchangers such as may be advantageously used in connection with the present invention.

As generally illustrated in FIGS. 2-4, a suction line heat exchanger may be provided in which the suction line tube **74** includes a generally straight portion which is cylindrical about an axis **96**. The capillary tube **60** may be variously positioned relative to the suction line tube **74** so that heat is exchanged between the tubes **74**, **60** as previously described.

For example, in FIG. 2, the capillary tube **60a** is helically wound around the suction line tube **74a**, where the helical winding of the capillary tube **60a** is generally around the axis **96** of the cylindrical suction line tube **74a**. Adequate operation, including desired heat exchange, can be provided for a typical application of the cooling system **10** of the present invention by a compact structure, using a capillary tube **60a** which is less than two (2) mm in diameter wrapped around only about twenty (20) inches of the suction line tube **74a**.

Alternatively, as shown in FIG. 3, the capillary tube **60b** may also be helically wound but with the helically wound portion inside of the suction line tube **74b**. Yet another simple alternative, shown in FIG. 4, is for the capillary tube **60c** to also be straight and positioned adjacent (or inside) the suction line tube **74c**.

Cooling systems **10** such as shown in FIG. 1 may use the FIG. 2-4 suction line heat exchangers. However, various advantageous new suction line heat exchangers are also disclosed herein and may also be advantageously used with cooling systems embodying the present invention, as well as others.

FIG. 5 discloses one such advantageous new suction line heat exchanger. In this embodiment, the suction line tube **74d** includes first and second substantially parallel straight cylindrical portions **100**, **102** connected in series, with the first straight portion **100** receiving gaseous liquid from the evaporator **28**, and the second straight portion **102** receiving gaseous refrigerant from the first straight portion **100**

through a U-shaped portion **104**. Gaseous refrigerant is output from the second straight portion **102** to the compressor **20**.

The capillary tube **60d** may carry cooled refrigerant to the evaporator **28**, and includes first and second helically wound portions **110**, **112** connected in series so that the second helically wound portion **112** receives cooled refrigerant from the first helically wound portion **110** through a connecting capillary tube portion **114**. The first helically wound portion **110** is wrapped around the suction line second straight cylindrical portion **102** and the second helically wound portion **112** is wrapped around the suction line first straight cylindrical portion **100**.

A suitable safety valve **120** is provided between the inlet and outlet of the capillary tube **60d**, where such safety valve **120** may function such as the inter-bleeding valve **64** as described in connection with FIG. 1. That is, the safety valve **120** is adapted to open at a pressure which is above the normal operating pressure of the system **10** (e.g., over 120 bar) so as to allow for bypassing around the capillary tube **60d** during extremely high pressures.

In the illustrated embodiment, the valve **120** includes a spring **122** with a selected strength sufficient to maintain the valve **120** seated unless the pressure on the high side (i.e., the pressure at the inlet to the capillary tube **60d**) is at least a selected level, in which case the pressure will be sufficient to overcome the force of the spring **122** and unseat the valve **120**. Unseating of the valve **120** will allow refrigerant to by-pass the capillary tube **60d** until the pressure returns below the selected maximum level. As previously indicated, such a pressure spike may occur during start up of a cooling system. During normal operation, the valve **120** will remain seated (closed). It should be understood that the particular valve structure illustrated in FIG. 5 is only exemplary, however, and that any valve structure suitable for the above described operation may be advantageously used with the illustrated embodiment.

It should be appreciated that the suction line heat exchanger illustrated in FIG. 5 may be advantageously used in many applications, particularly those in which space is at a premium, as the illustrated heat exchanger may maximize heat exchange in a relatively short (narrow) space.

FIG. 6 illustrates yet another embodiment of an advantageous suction line heat exchanger. In this illustrated embodiment, the suction line heat exchanger is substantially similar to the FIG. 5 embodiment except that the suction line tube **74e** includes an in-line accumulator **130** with an oil return hole **132** in place of the U-shaped portion of FIG. 5. It should be appreciated that, like the FIG. 5 embodiment, the FIG. 6 embodiment may also be advantageously used in many applications, particularly those in which space is at a premium, with the illustrated heat exchanger maximizing heat exchange in a relatively short (narrow) space.

FIG. 7 illustrates still another embodiment of an advantageous structure between the evaporator **28** and compressor **20** of a cooling system **10**, including a suction line heat exchanger. Specifically, the heat exchanger is illustrated as being such as shown in FIG. 2, with the capillary tube **60f** helically wound around a straight portion of the suction line tube **74f**. However, it should be understood that the suction line heat exchanger of the FIG. 7 embodiment could be in still other suitable forms, such as those shown in FIGS. 3-5.

An accumulator **140** is provided between the suction line heat exchanger and the evaporator. Specifically, the accumulator **140** includes a separation chamber or housing **142** with an inlet **144** receiving refrigerant from the evaporator. A vertical suction line tube **146** is connected at its lower end

to the portion of the suction line tube **74f** in the suction line heat exchanger (with the capillary tube **60f**), and on its upper end **148** is open inside the separation housing **142** and spaced from the bottom of the housing **142**. Accordingly, gaseous or two phase refrigerant from the evaporator **28** enters the separation housing **142** at inlet **144**, oil and liquid droplets in the refrigerant will drop out of the refrigerant so that the refrigerant which enters the upper end **148** of the suction line tube **146** to exit the housing **142** will have a desirably reduced amount of liquid droplets mixed therein.

An accumulator housing **150** is disposed beneath the separation housing **142** and is connected thereto by a vertical pipe **154**. Oil and liquid droplets which are separated from the refrigerant will drain down through the vertical pipe **154** to the accumulator housing **150**, and from there may be suitably recirculated via an oil return hole **156** in the accumulator housing **150**. A second vertical pipe **160** is also illustrated as connecting the separation housing **142** and accumulator housing **150**. However, it should be appreciated that still more vertical pipes could also be included within the scope of the present invention.

The Vertical pipes **154**, **160** not only connect the housings **142**, **150**, but also provide storage volume for oil and system charge. It should be appreciated that through the use of such pipes **154**, **160**, the accumulator **140** may be readily adapted for different requirements. For example, in an environment where an increased storage volume may be required, this may be provided by simply increasing the length of the tubes **154**, **160** and correspondingly increasing the spacing between the housing **142**, **150**. By contrast, increasing the volume per unit height ratio could require use of thicker materials, and therefore increase the weight of the structure. Increased weight can make a structure unacceptable in some applications where weight is important.

The second vertical pipe **160** as illustrated in FIG. 7 is straight. However, it should be appreciated that it would be within the scope of the present invention to use other vertically extending pipe structures which provide storage volume for charge and separated oil, including more than two such pipes, and different shaped pipes, such as a pipe which is helically wound around the vertical suction line tube **146** and/or other vertical pipes between the housings **142**, **150**.

It should be appreciated that advantageous cooling may be efficiently and reliably provided with the above described compact cooling system **10**. It should further be appreciated that advantageous cooling may be efficiently and reliably provided through the use of compact, low weight suction line heat exchangers such as also described above.

Still other aspects, objects, and advantages of the present invention can be obtained from a study of the specification, the drawings, and the appended claims. It should be understood, however, that the present invention could be used in alternate forms where less than all of the objects and advantages of the present invention and preferred embodiment as described above would be obtained.

The invention claimed is:

1. In a cooling system having a refrigerant evaporator, a heat exchanger comprising:
  - a suction line for refrigerant output from said evaporator, said suction line including first and second substantially parallel straight cylindrical portions connected in series;
  - a capillary tube adapted to carry cooled refrigerant to said evaporator, said capillary tube including first and second helically wound portions connected in series whereby said second helically wound portion receives

7

cooled refrigerant from said first helically wound portion, said first helically wound portion being wrapped around said suction line second straight cylindrical portion and said second helically wound portion being wrapped around said suction line first straight cylindrical portion; and  
 5 an accumulator between said first and second cylindrical portions of said suction line;  
 whereby said suction line first straight cylindrical portion outputs gaseous refrigerant to said accumulator and said suction line second straight cylindrical portion receives gaseous refrigerant from said accumulator.  
 10  
 2. The heat exchanger of claim 1, wherein said refrigerant comprises CO<sub>2</sub> and said capillary tube is an expansion device for said cooled CO<sub>2</sub> refrigerant.  
 15  
 3. The heat exchanger of claim 1, wherein said cooling system is transcritical.  
 4. In a cooling system having a refrigerant evaporator, a heat exchanger comprising:  
 20 a suction line for refrigerant output from said evaporator, said suction line including first and second substantially parallel straight cylindrical portions connected in series whereby said second straight cylindrical portion receives gaseous refrigerant from said first straight cylindrical portion;  
 25 a capillary tube adapted to carry cooled refrigerant to said evaporator, said capillary tube including first and sec-

8

ond helically wound portions connected in series whereby said second helically wound portion receives cooled refrigerant from said first helically wound portion, said first helically wound portion being wrapped around said suction line second straight cylindrical portion and said second helically wound portion being wrapped around said suction line first straight cylindrical portion; and  
 a bypass safety valve between an inlet to said first helically wound portion of said capillary tube and an outlet from said second helically wound portion of said capillary tube, said bypass safety valve opening responsive to a selected pressure differential between said inlet to said first helically wound portion of said capillary tube and said outlet from said second helically wound portion of said capillary tube.  
 5. The heat exchanger of claim 4, further comprising an accumulator between said first and second cylindrical portions of said suction line.  
 6. The heat exchanger of claim 4, wherein said refrigerant comprises CO<sub>2</sub> and said capillary tube is an expansion device for said cooled CO<sub>2</sub> refrigerant.  
 7. The heat exchanger of claim 4, wherein said cooling system is transcritical.

\* \* \* \* \*