



INTERNATIONAL APPLICATION PUBLISHED UNDER THE PATENT COOPERATION TREATY (PCT)

(51) International Patent Classification ⁶ : A61B 17/34, A61M 39/06, A61F 9/007	A1	(11) International Publication Number: WO 97/47247 (43) International Publication Date: 18 December 1997 (18.12.97)
(21) International Application Number: PCT/IL97/00171 (22) International Filing Date: 29 May 1997 (29.05.97) (30) Priority Data: 118653 13 June 1996 (13.06.96) IL 119813 12 December 1996 (12.12.96) IL (71) Applicant (for all designated States except US): SMOLLETT, Neil [IL/IL]; Granot, Strauss & Co., Yahalom Tower, 25th floor, Jabotinski Street 3A, 52520 Ramat Gan (IL). (72) Inventor; and (75) Inventor/Applicant (for US only): BEN NUN, Yehoshua [IL/IL]; Moshav Beit Herut 1/A, D.N., 40291 Vitkin (IL). (74) Agent: REINHOLD COHN & PARTNERS; P.O. Box 4060, 61040 Tel Aviv (IL).	(81) Designated States: AL, AM, AT, AU, AZ, BA, BB, BG, BR, BY, CA, CH, CN, CU, CZ, DE, DK, EE, ES, FI, GB, GE, GH, HU, IL, IS, JP, KE, KG, KP, KR, KZ, LC, LK, LR, LS, LT, LU, LV, MD, MG, MK, MN, MW, MX, NO, NZ, PL, PT, RO, RU, SD, SE, SG, SI, SK, TJ, TM, TR, TT, UA, UG, US, UZ, VN, YU, ARIPO patent (GH, KE, LS, MW, SD, SZ, UG), Eurasian patent (AM, AZ, BY, KG, KZ, MD, RU, TJ, TM), European patent (AT, BE, CH, DE, DK, ES, FI, FR, GB, GR, IE, IT, LU, MC, NL, PT, SE), OAPI patent (BF, BJ, CF, CG, CI, CM, GA, GN, ML, MR, NE, SN, TD, TG). Published <i>With international search report.</i>	

(54) Title: SURGICAL SEALING SLEEVE

(57) Abstract

A surgical sealing sleeve (1, 32) for preventing undesirable leakage from the humoral fluid filled interior of a mammal organ to an access environment during its temporary seating in an access tissue to the mammal organ. The surgical sealing sleeve (1, 32) has an axially extending rigid tubular sleeve (2) for attachment to the access tissue and having an axially extending passageway (5). The sleeve (2) includes an inner sleeve member (3, 33) nested at least along a portion of its length within an outer sleeve member (4). Each of the inner and outer sleeve members has a proximal end and a distal end, the inner sleeve member (3, 33) having at least one distally directed sheath support member (9A and 9B, 34) terminating proximal to the distal end of the outer sleeve member. An elastomeric sheath (10) is sealingly interdisposed between the inner and outer sleeve members and distally extending so as to fit over the at least one sheath support member, the elastomeric sheath having a *a priori* sealed end adapted to be cut *in situ* so as to provide an unidirectional slit valve (13A and 13B, 38) normally closed under the pressure prevailing in the mammal organ's interior so as to prevent leakage of its contents therefrom via the passageway to the access environment.

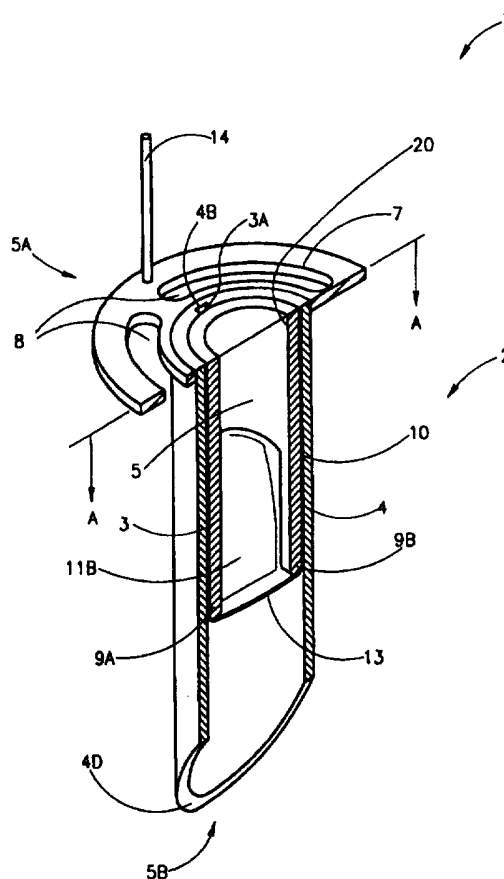

FOR THE PURPOSES OF INFORMATION ONLY

Codes used to identify States party to the PCT on the front pages of pamphlets publishing international applications under the PCT.

AL	Albania	ES	Spain	LS	Lesotho	SI	Slovenia
AM	Armenia	FI	Finland	LT	Lithuania	SK	Slovakia
AT	Austria	FR	France	LU	Luxembourg	SN	Senegal
AU	Australia	GA	Gabon	LV	Latvia	SZ	Swaziland
AZ	Azerbaijan	GB	United Kingdom	MC	Monaco	TD	Chad
BA	Bosnia and Herzegovina	GE	Georgia	MD	Republic of Moldova	TG	Togo
BB	Barbados	GH	Ghana	MG	Madagascar	TJ	Tajikistan
BE	Belgium	GN	Guinea	MK	The former Yugoslav Republic of Macedonia	TM	Turkmenistan
BF	Burkina Faso	GR	Greece	ML	Mali	TR	Turkey
BG	Bulgaria	HU	Hungary	MN	Mongolia	TT	Trinidad and Tobago
BJ	Benin	IE	Ireland	MR	Mauritania	UA	Ukraine
BR	Brazil	IL	Israel	MW	Malawi	UG	Uganda
BY	Belarus	IS	Iceland	MX	Mexico	US	United States of America
CA	Canada	IT	Italy	NE	Niger	UZ	Uzbekistan
CF	Central African Republic	JP	Japan	NL	Netherlands	VN	Viet Nam
CG	Congo	KE	Kenya	NO	Norway	YU	Yugoslavia
CH	Switzerland	KG	Kyrgyzstan	NZ	New Zealand	ZW	Zimbabwe
CI	Côte d'Ivoire	KP	Democratic People's Republic of Korea	PL	Poland		
CM	Cameroon	KR	Republic of Korea	PT	Portugal		
CN	China	KZ	Kazakstan	RO	Romania		
CU	Cuba	LC	Saint Lucia	RU	Russian Federation		
CZ	Czech Republic	LI	Liechtenstein	SD	Sudan		
DE	Germany	LK	Sri Lanka	SE	Sweden		
DK	Denmark	LR	Liberia	SG	Singapore		
EE	Estonia						

SURGICAL SEALING SLEEVE

FIELD OF THE INVENTION

The present invention is in the field of surgical sealing sleeves for providing temporary access to the interior of a mammal organ in general. In particular, the present invention relates to a surgical sealing sleeve having a unidirectional valve at its distal end for preventing undesirable leakage from a mammal organ's interior to an access environment.

BACKGROUND OF THE INVENTION

Intraocular surgical procedures require three or more sclerotomies for enabling the introduction into an eye's interior of a light probe and a surgical instrument and the connection to either a supply line to a source of pressurized air or an irrigation line to a source of physiological liquid for maintaining normal intraocular pressure despite a continuous undesirable leakage from the eye's interior through the sclerotomies. In view of physiological considerations, the diameter of a sclerotomy is limited to between about 1 mm – 1.5 mm.

US Patent 4,795,426 describes a tip portion for a catheter placement cannula, the tip portion being in the form of a pair of flexible lips

which assume a naturally flattened shape to provide a seal for preventing the backflow of blood or other fluids. To this end, the lips are made of shape retaining memory material of a relatively thick dimension. In view of such a construction, the tip portion is suitable for insertion into a large access port as made in, for example, an abdominal wall, however, it does not lend itself for miniaturization for insertion into a small access port, for example, a sclerotomy.

SUMMARY OF THE INVENTION

10 It is an object of the present invention to provide a novel surgical sealing sleeve enabling temporary access to the interior of a mammal organ and having a unidirectional valve at its distal end for preventing undesirable leakage from a mammal organ's interior to an access environment.

15 In accordance with the teachings of the present invention, there is provided a surgical sealing sleeve for preventing undesirable leakage from the humoral fluid filled interior of a mammal organ to an access environment during its temporary seating in an access tissue to the mammal organ, the surgical sealing sleeve comprising:

- 20 (a) an axially extending rigid tubular sleeve for attachment to the access tissue and having an axially extending passageway, said sleeve including an inner sleeve member nested at least along a portion of its length within an outer sleeve member, each of said inner and outer sleeve members having a proximal end and a distal end, said inner sleeve member having at least one distally directed sheath support member terminating proximal to said distal end of said outer sleeve member; and
- 25 (b) an elastomeric sheath sealingly interdisposed between said inner and outer sleeve members and distally extending so as

5 to fit over said at least one sheath support member, said elastomeric sheath having a *a priori* sealed end adapted to be cut *in situ* so as to provide an unidirectional slit valve normally closed under the pressure prevailing in the mammal organ's interior so as to prevent leakage of its contents therefrom via said passageway to the access environment.

10 The surgical sealing sleeve in accordance with the teachings of the present invention particularly lends itself as an ophthalmic surgical sealing sleeve in that it can be readily miniaturized to a size suitable for insertion into a sclerotomy, e.g., having a diameter in the range of about 1 mm – 1.5 mm. However, that notwithstanding, it will be readily appreciated that the surgical sealing sleeve can be adapted for use in large access ports.

15 The proximal end of the sleeve is preferably formed with an upright projection for releasable insertion into a matching bore in a cutting tool employed for cutting the elastomeric sheath to form the unidirectional slit valve. The projection cum bore ensure that the cutting tool can only cut the elastomeric sheath in a predetermined manner and that the depth of insertion of the cutting tool into the eye is limited to as to prevent infliction
20 of damage to the eye's interior structure.

In addition, the proximal end of the sleeve is preferably formed with an internal screw thread for releasable engagement with an insertion tool employed for manipulating the surgical sealing sleeve prior to a surgical procedure in general and in particular during a sclerotomy and its subsequent
25 removal therefrom.

Due to the lack of elasticity of an eye's sclera, the surgical sealing sleeve is preferably operable as a trocar for puncturing its own sclerotomy, thereby meritoriously reducing leakage between the sclerotomy's rim and the surgical sealing sleeve's outer surface. The projection preferably doubles as

an indicating means for indicating the trocar end of the surgical sealing sleeve.

Further objects, features and advantages of the present invention will become apparent from the following detailed description when take in
5 conjunction with the accompanying drawings wherein like reference numerals designate like elements through the several views.

BRIEF DESCRIPTION OF THE DRAWINGS

Fig. 1 is a partial cross section perspective view of an assembled
10 surgical sealing sleeve in accordance with a first embodiment of the present invention;

Fig. 2 is an exploded view of the surgical sealing sleeve of Figure 1 along with its cutting tool and its insertion tool;

Figs. 3A and 3B are respectively a schematic cross section side
15 view and a front view of a human eye into whose sclera three surgical sealing sleeves of Figure 1 have been temporarily inserted;

Fig. 4 is a cross section view along line A-A in Figure 1 showing the insertion of the surgical sealing sleeve into an eye's sclera;

Fig. 5 is a cross section view along line A-A in Figure 1 showing
20 the removal of the insertion tool from the surgical sealing sleeve;

Fig. 6 is a cross section view along line A-A in Figure 1 showing the cutting of the sheath's sealed end with a cutting tool;

Fig. 7 is a cross section view along line A-A in Figure 1 showing the sealing action of the surgical sealing sleeve's unidirectional slit valve;

Fig. 8 is an exploded view of a surgical sealing sleeve in
25 accordance with a second embodiment of the present invention; and

Fig. 9 is a partial cross sectional perspective view of the surgical sealing sleeve of Figure 8 showing the sealing action of its unidirectional slit valve.

DETAILED DESCRIPTION OF THE INVENTION

With reference now to the drawings, Figures 1 and 2 show a surgical sealing sleeve 1 including an axially extending rigid tubular sleeve 2 constituted by an inner sleeve member 3 and an outer sleeve member 4 coaxially disposed therewith and having an axial slit 4A. The sleeve 2 has a passageway 5 axially extending between a proximal end 5A associated with an access environment and a distal end 5B associated with the interior of a mammal eye.

At their proximal ends, the inner sleeve member 3 is formed with a stop 3A adapted for insertion into a matching slot 4B formed in the outer sleeve member 4. In addition, the outer sleeve member 4 is formed with an external screw thread 4C at its proximal end on which is screw threaded an annular fixation plate 7 having two or more apertures 8 enabling suture fixation of the surgical sealing sleeve 1 to an eye's sclera.

At their distal ends, the inner sleeve member 3 is formed with a pair of sheath support members in the form of diametrically opposite axially directed rods 9A and 9B whilst the outer sleeve member 4 is fashioned with a puncturing tip 4D such that the surgical sealing sleeve 1 is operable as trocar. For reasons to become apparent hereinbelow, the tips of the 9A and 9B lie proximal of the puncturing tip 4D and within the full cylindrical portion of the outer sleeve member 4.

On assembly of the surgical sealing sleeve 1, an ultrafine elastomeric sheath 10 of about 0.5 mm thickness and having a sealed sheath end 13 is rolled onto the inner sleeve member 3. The elastomeric sheath 10 is so deployed such that in its relaxed state, its end 13 extends very slightly beyond the tips of the rods 9A and 9B, thereby presenting side walls 11A and 11B converging at a transversely directed sealed sheath end 13.

Thereafter, the outer sleeve member 4 is slightly pried open and the inner sleeve member 3, along with the elastomeric sheath 10 is inserted therein in a distal direction until the stop 3A seats in the slot 4B. Finally, the annular fixation plate 7 is screw threaded onto the outer sleeve member 4 to seal the elastomeric sheath 10 between the inner and outer sleeve member 3 and 4 at the proximal end of the surgical sealing sleeve 1.

The annular fixation plate 7 is formed with an upright projection 14 for releasable insertion in a matching bore 15 formed in a cutting tool 16 having a blade 17 with a wide root tapering to a central stylet tip 19 for initiating the cutting of the sealed sheath end 13. The matching projection 14 and bore 15 are axially dimensioned such that on insertion of the cutting tool 16 into the surgical sealing sleeve 1, the blade 17 cuts along the sealed sheath end 13 between the tips of the rods 9A and 9B so as to form a pair of transversely directed end margins 13A and 13B respectively of side walls 11A and 11B, the end margins 13A and 13B constituting the unidirectional slit valve. Against this, when the bore 15 is not in registration with the projection 14, thereby enabling only the partial insertion of the cutting tool 16 into the surgical sealing device 1, the tool's blade 17 cannot rupture the elastomeric sheath 10.

At its proximal end, the inner sleeve member 3 is formed with an internal screw thread 20 for releasable engagement with a matching external screw thread 21 of a hand held insertion tool 22. The insertion tool 22 is also provided an axially extending lumen 23 to preclude a suction force being developed on its removal from the surgical sealing sleeve 1 which would have a tendency to invert the sealed sheath end 13 into the passageway 5 possibly causing it to rupture.

The insertion tool 22 is axially dimensioned such that on screw engagement with the inner sleeve member 3, its tip bears against the sealed sheath end 13 so as to stretch the elastomeric sheath 10 lengthwise to take

up any slack in the side walls 11A and 11B, thereby presenting a smooth contour along the sleeve's entire length such that it can be pushed through a relatively coarse access tissue without it being torn or otherwise damaged. However, at the same time, the insertion tool 22 is axially dimensioned such
5 that the sealed sheath end 13 does not protrude beyond the distal end of the outer sleeve member 4 which would expose the sealed sheath end 13 which then maybe ruptured during a forced insertion through an access tissue.

The deployment and use of the surgical sealing sleeve 1 is now described within the context of a sclera-invasive intraocular surgery as
10 schematically shown in Figures 3A and 3B in which three surgical sealing sleeves 1A, 1B and 1C have been temporarily inserted into a sclera A of an eye C. As shown, the surgical sealing sleeves 1A, 1B and 1C are respectively employed for enabling the introduction of a surgical instrument 28 and a light source 29 into the eye's vitreous chamber B and connection
15 to an irrigation line 31. Preferably, the light source 29 and the irrigation line 31 are screw threaded into the surgical sealing sleeves 1B and 1C, respectively.

As shown in Figure 4, the first stage in the deployment of a surgical sealing sleeve 1, is screwing in the insertion tool 22 such that the
20 surgical sealing sleeve 1 can be hand manipulated for sclerotomy whilst the integrity of its elastomeric sheath 10 is maintained as described hereinabove. During sclerotomy, the projection 14 is used to orient the surgical sealing sleeve 1 such that the puncturing tip 4D does not afflict any damage to an eye's internal structure. As shown in Figure 5, after suture fixation of the
25 surgical sealing sleeve 1 to sclera A, the insertion tool 22 is unscrewed and removed leaving a still sealed elastomeric sheath 10 which contracts to its original length.

Thereafter, as shown in Figure 6, the cutting tool 16 is oriented such that its bore 15 is in registration with the sleeve's projection 14 such

that on insertion into the surgical sealing sleeve 1, it cuts the sealed sheath end 13 to form the end margins 13A and 13B. On removal of the cutting tool 16, the end margins 13A and 13B seal against one another under the pressure prevailing in the eye's interior, thereby preventing undesirable leakage of intraocular fluid to the exterior whilst at the same time enabling the repeated passage of different surgical instrument into the eye's interior therebetween. The fact that the side walls 11A and 11B distally extend only slightly further than the rods 9A and 9B ensures that the end margins 13A and 13B cannot be inverted and also that they readily part on the passage of a surgical instrument therebetween.

On removal of the surgical sealing sleeve 1 from the eye, by virtue of the distal location of the unidirectional slit valve, a minimal suction force is applied to contents of the vitreous chamber B, thereby minimizing the damage thereto.

With reference now to Figure 8, a surgical sealing sleeve 32 is similar to the surgical sealing sleeve 1 except that its inner sleeve member 33 includes a single axially extending, peripherally curved sheath support member 34. The surgical sealing sleeve 32 requires the use of a cutting tool 35 with a stylet tip shaped blade 37 so as to cut the elastomeric sheath 10 to form a sealing flap 38 adapted to seal against the inner surface of the sheath support member 34.

While the invention has been described with respect to a limited number of embodiments, it will be appreciated that many variations, modifications and other applications of the invention may be made.

CLAIMS:

1. A surgical sealing sleeve for preventing undesirable leakage from the humoral fluid filled interior of a mammal organ to an access environment during its temporary seating in an access tissue to the mammal organ, the surgical sealing sleeve comprising:

- (a) an axially extending rigid tubular sleeve for attachment to the access tissue and having an axially extending passageway, said sleeve including an inner sleeve member nested at least along a portion of its length within an outer sleeve member, each of said inner and outer sleeve members having a proximal end and a distal end, said inner sleeve member having at least one distally directed sheath support member terminating proximal to said distal end of said outer sleeve member; and
- (b) an elastomeric sheath sealingly interdisposed between said inner and outer sleeve members and distally extending so as to fit over said at least one sheath support member, said elastomeric sheath having a *a priori* sealed end adapted to be cut *in situ* so as to provide an unidirectional slit valve normally closed under the pressure prevailing in the mammal organ's interior so as to prevent leakage of its contents therefrom via said passageway to the access environment.

2. A surgical sealing sleeve according to claim 1 wherein the proximal end of the sleeve is provided with an upright projection for releasable insertion in a matching bore of a cutting tool.

3. A surgical sealing sleeve according to either claim 1 or 2 wherein the proximal end of the sleeve is provided with an internal screw thread for releasable screw engagement with an insertion tool.
4. A surgical sealing sleeve according to any one of claims 1-3 wherein the distal end of the sleeve is formed as a trocar.
5. A surgical sealing sleeve according to claim 4 wherein the proximal end of the sleeve is formed with indicating means for indicating the position of the trocar.
6. A surgical sealing sleeve according to claim 5 wherein said indicating means is constituted by a proximally directed projection for releasable insertion in a matching bore of a cutting tool.
7. A surgical sealing sleeve according to any one of claims 1-6 wherein said unidirectional slit valve includes two transversely directed end margins adapted to seal against one another.
8. A surgical sealing sleeve according to any one of claims 1-6 wherein said unidirectional slit valve includes a sealing flap adapted to seal against the inner surface of an axially extending peripherally curved sheath support member.
9. A cutting tool for use with a surgical sealing sleeve as claimed in claim 2, the cutting tool comprising a blade.

10. An insertion tool for use with a surgical sealing sleeve as claimed in claimed 3, the insertion tool comprising an axially extending body member having an axially extending lumen.

1/8

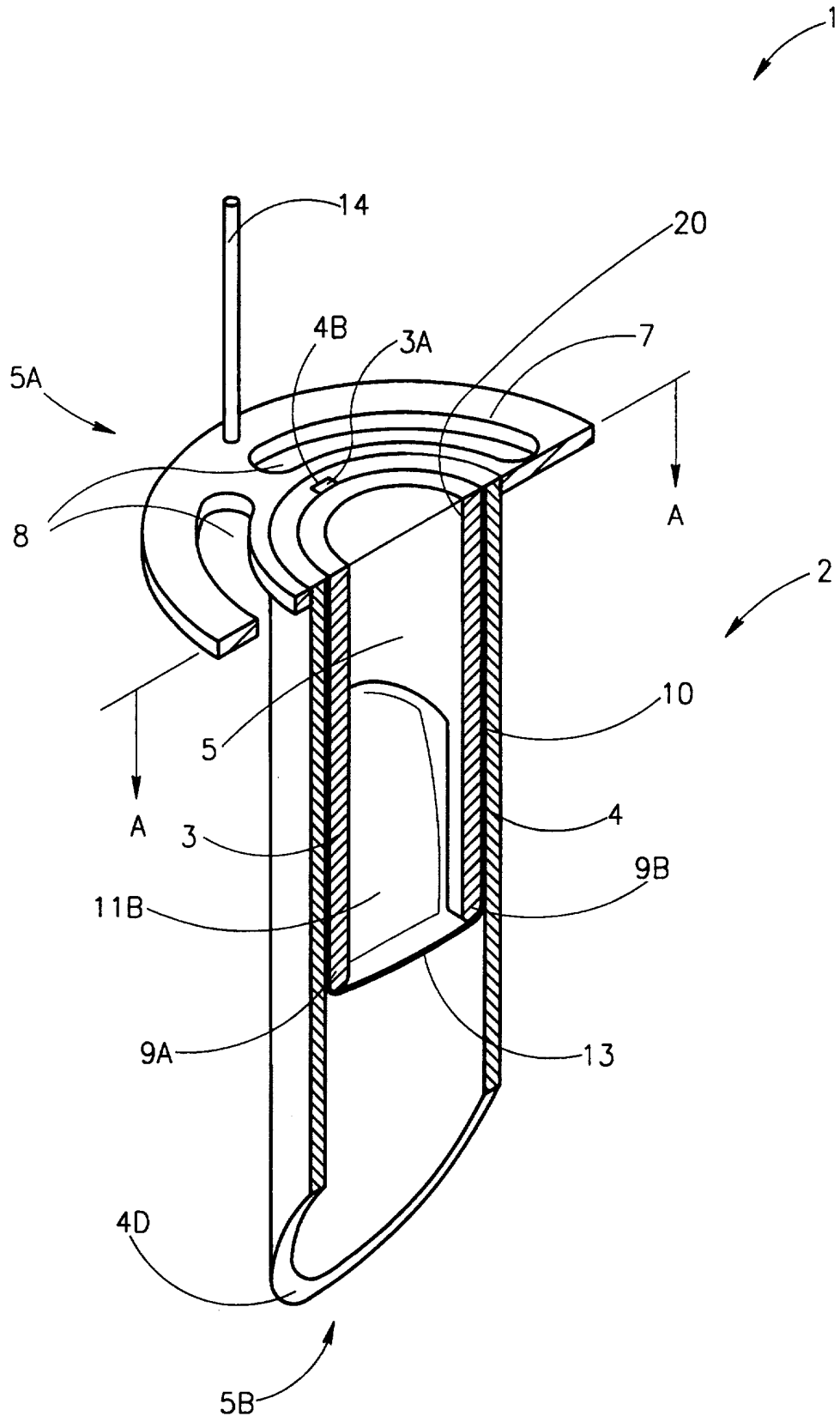

FIG. 1

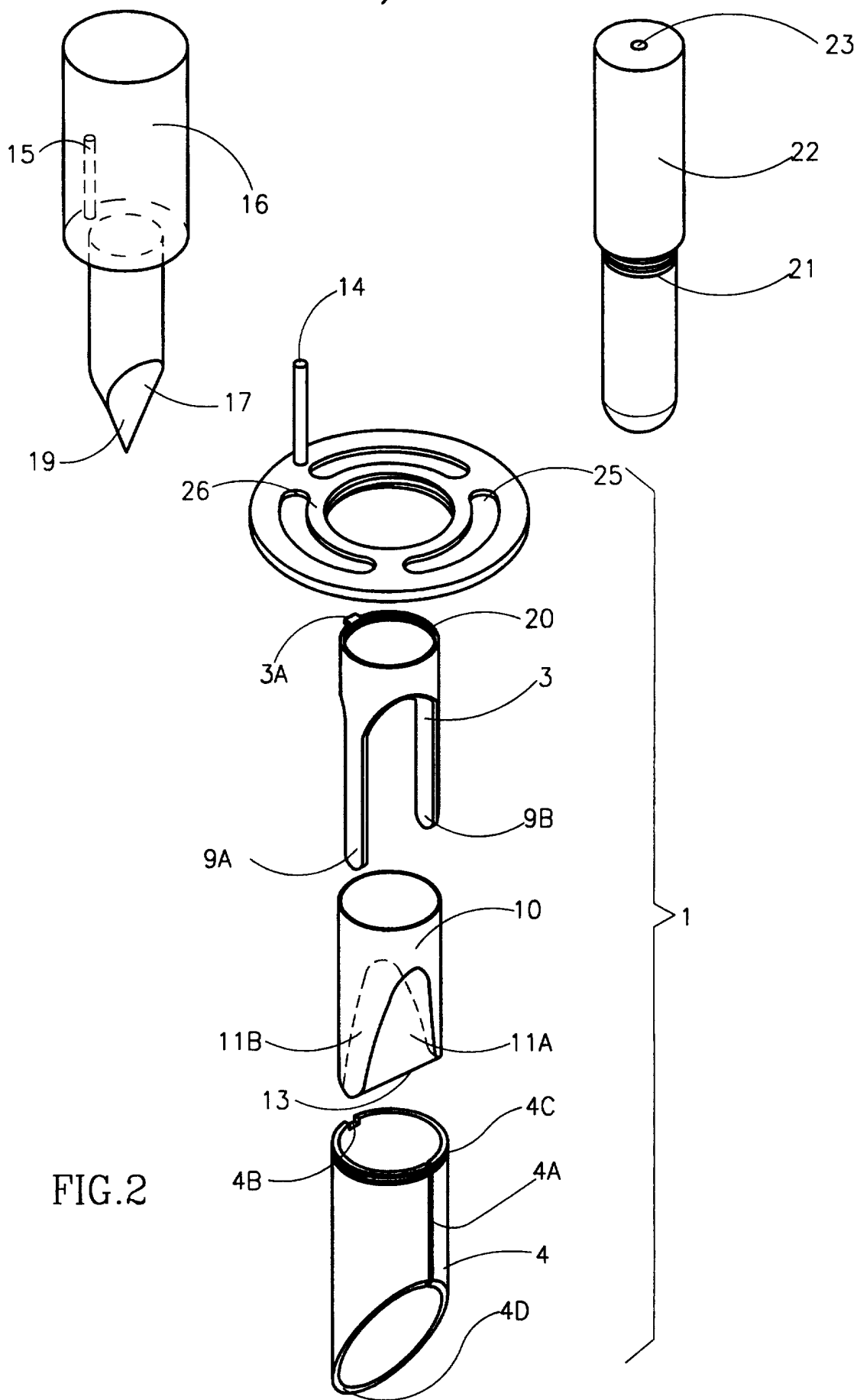

FIG. 2

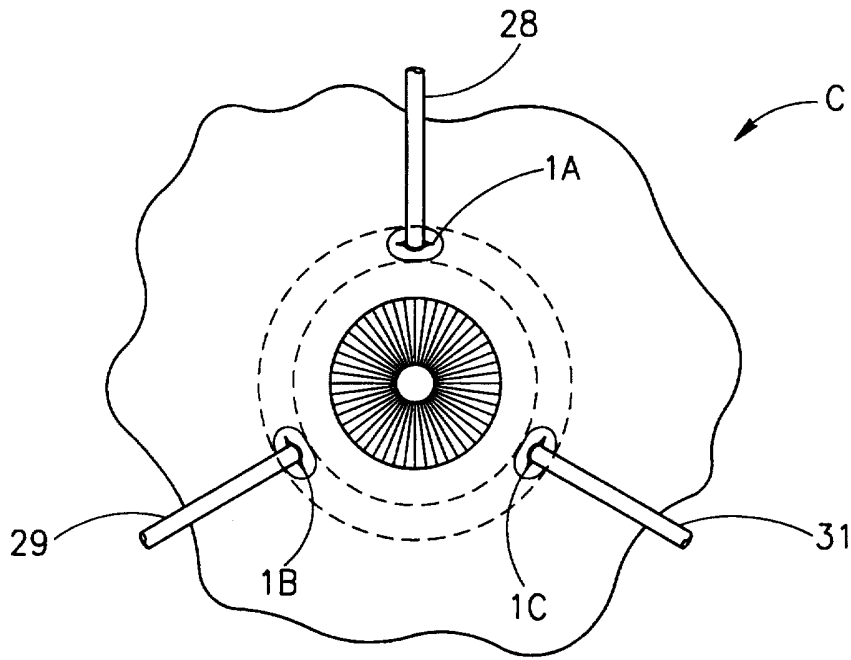
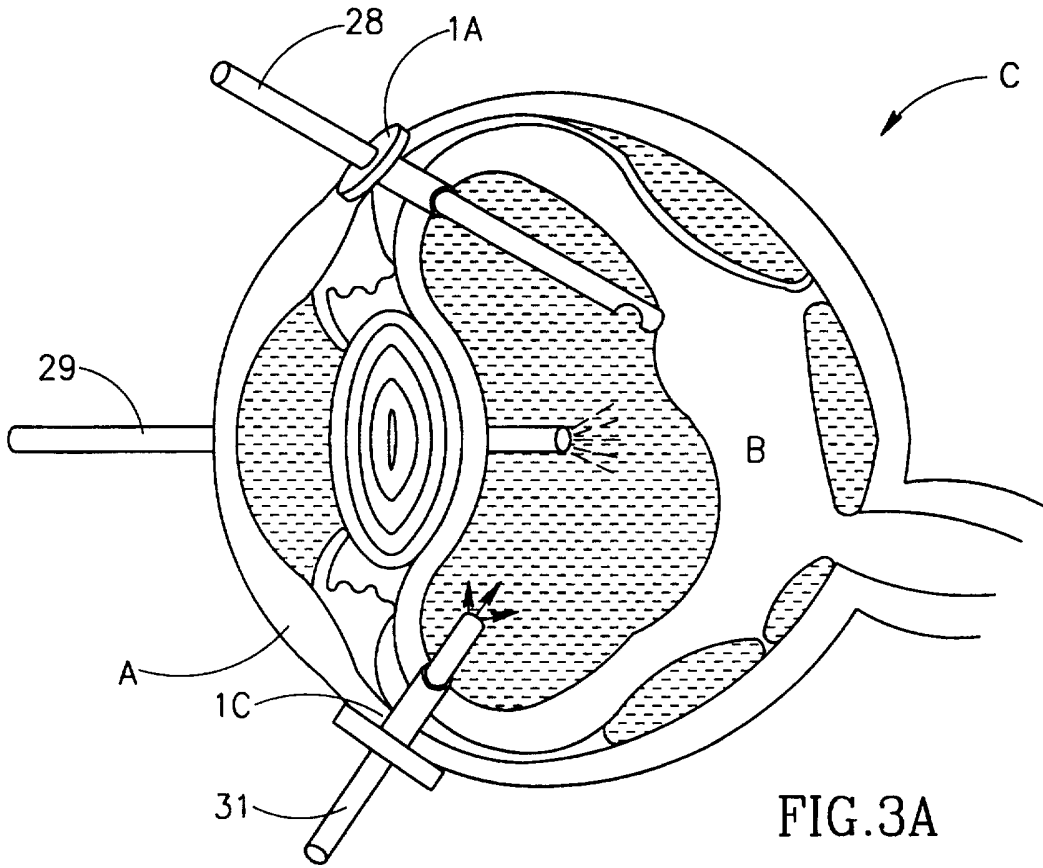

FIG. 3B

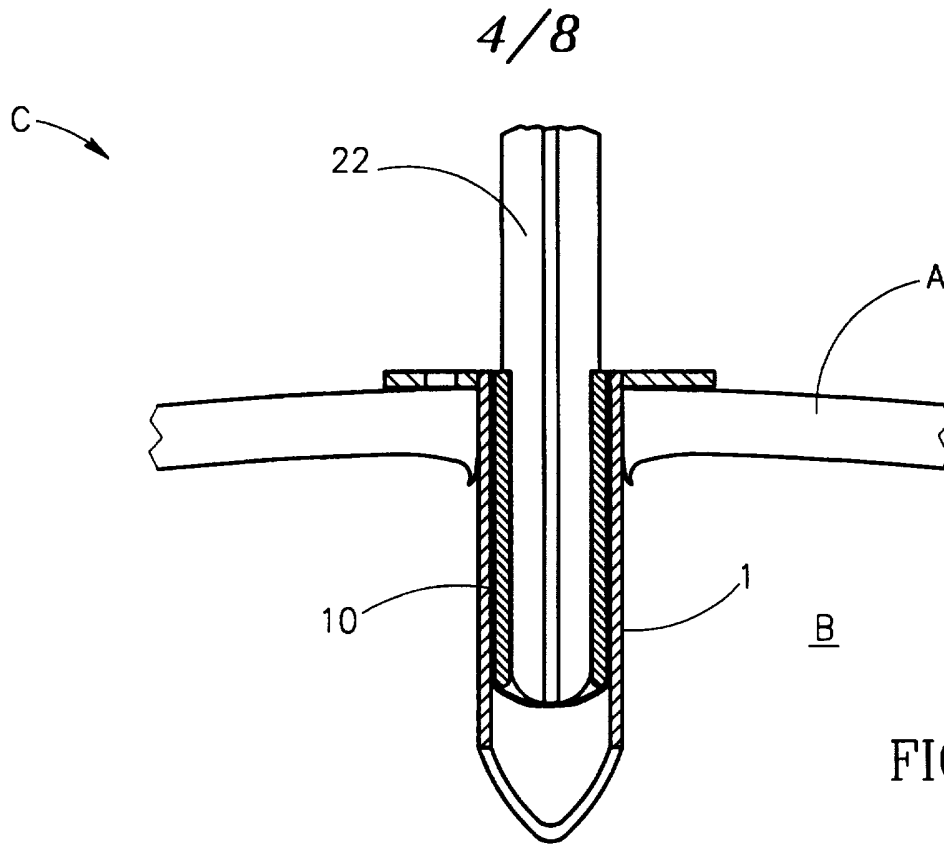

FIG. 4

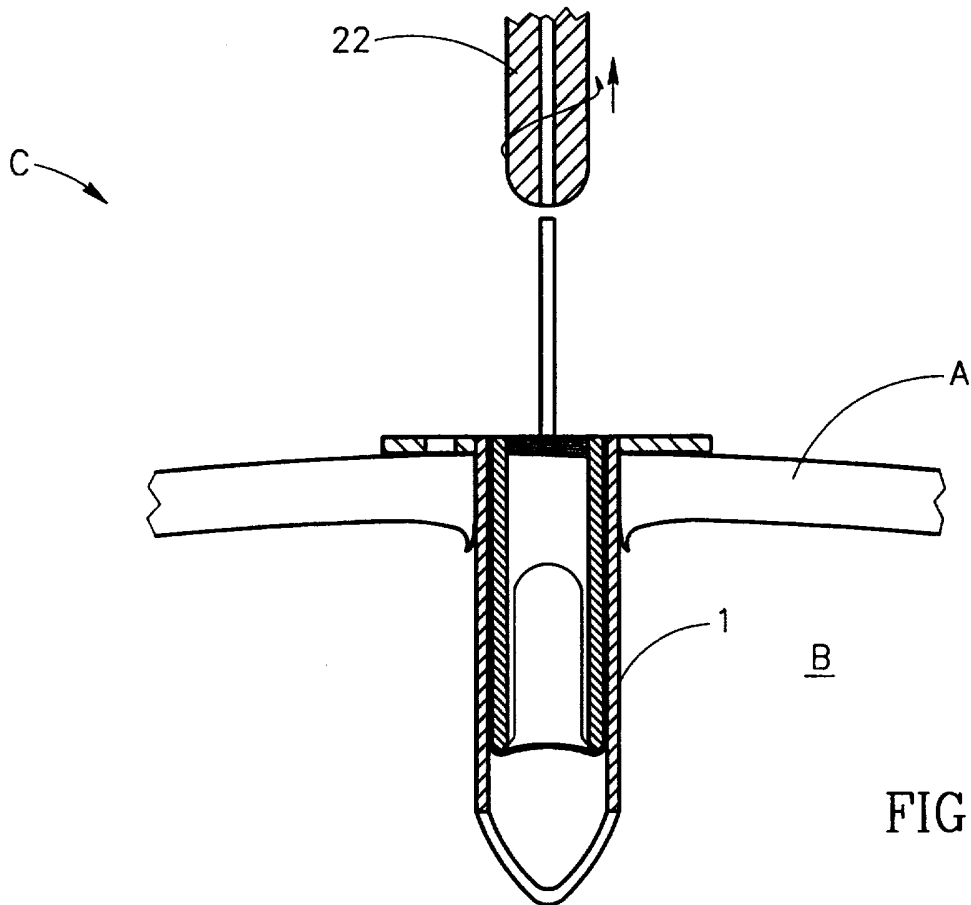

FIG. 5

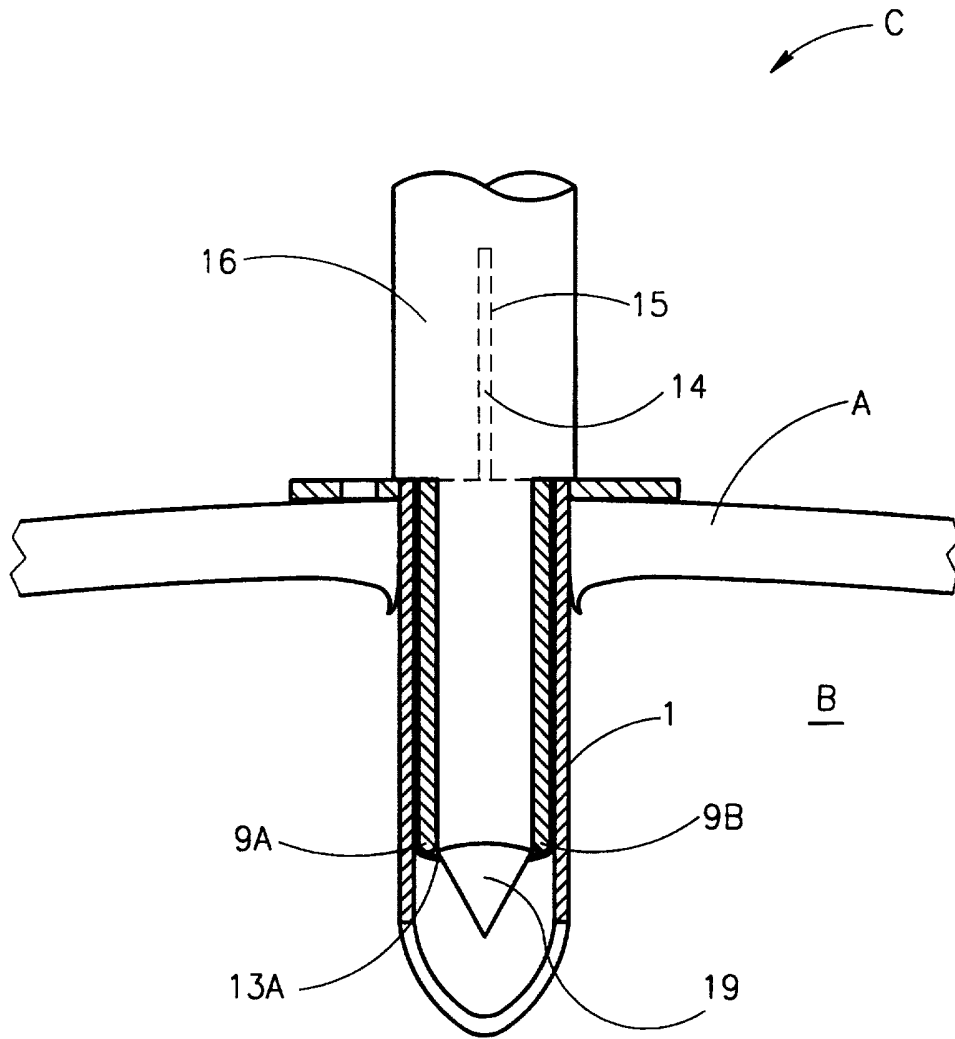

FIG. 6

6/8

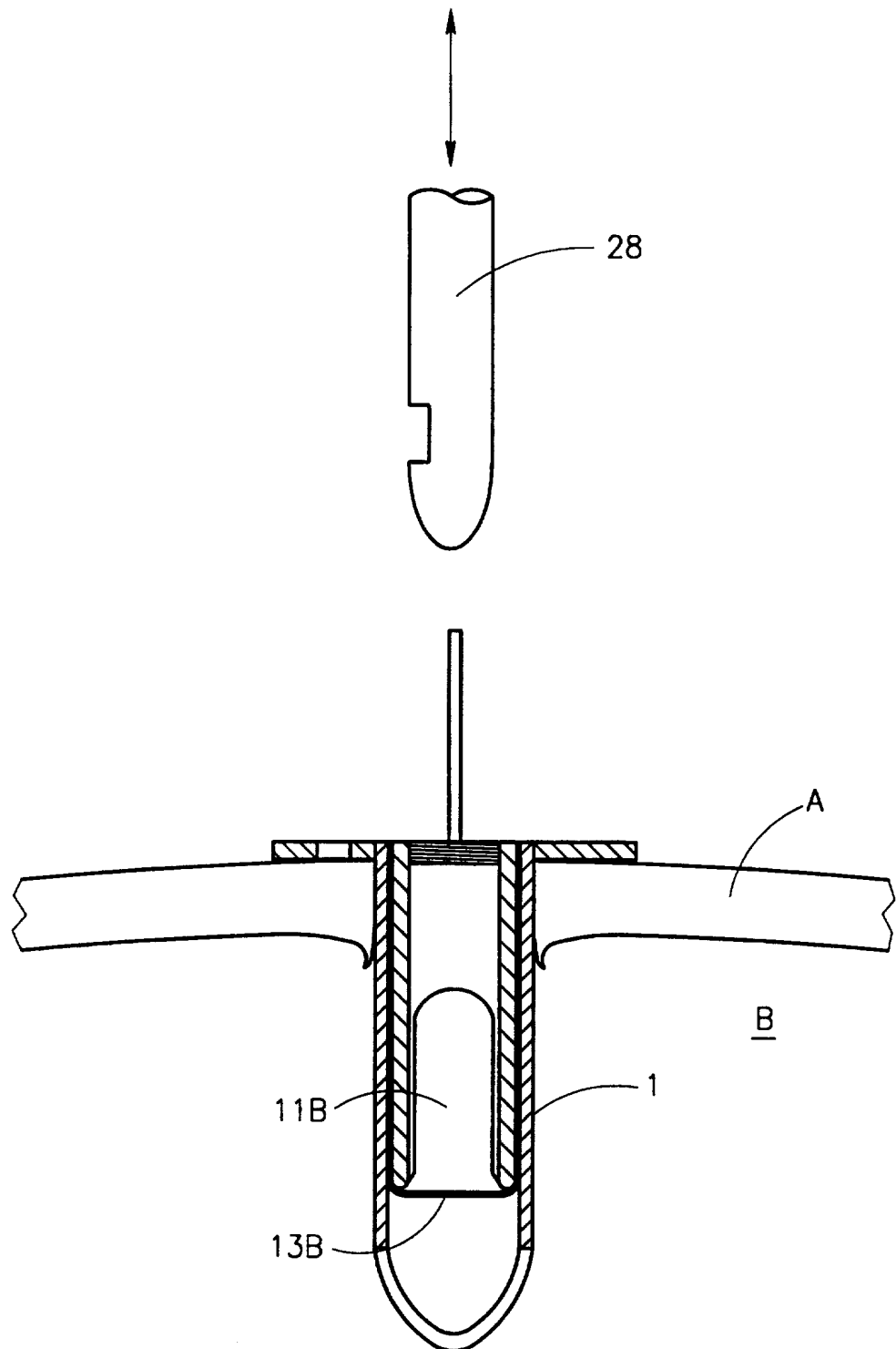

FIG. 7

7/8

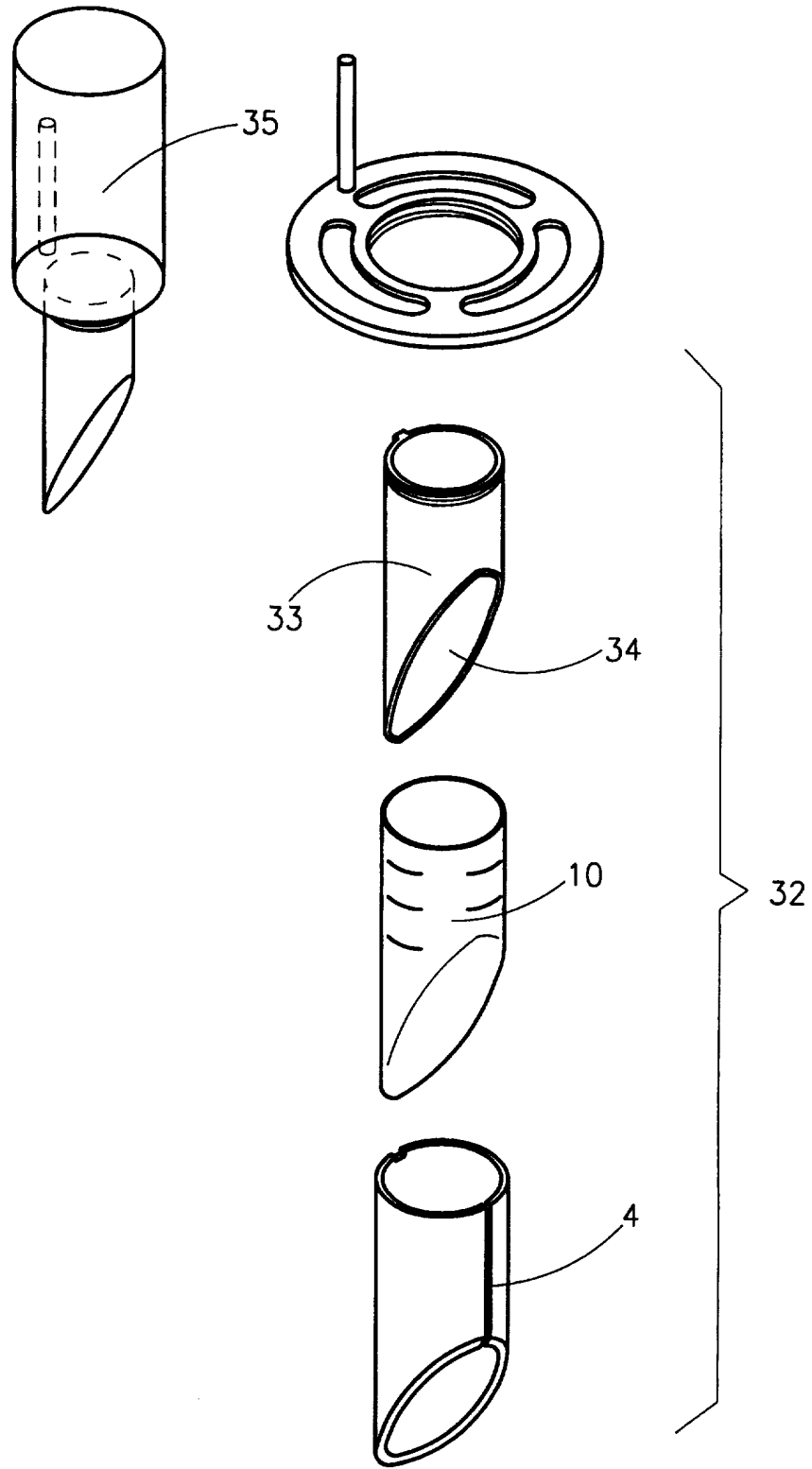

FIG.8

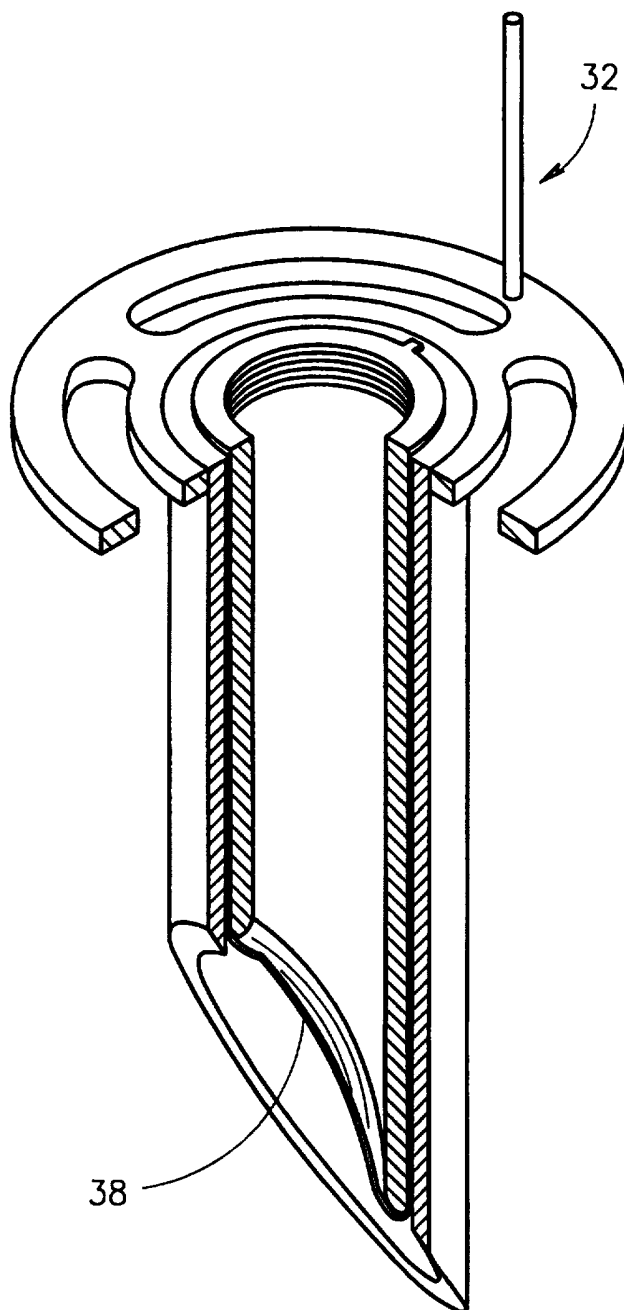

FIG.9

INTERNATIONAL SEARCH REPORT

Intern. Application No
PCT/IL 97/00171

A. CLASSIFICATION OF SUBJECT MATTER
IPC 6 A61B17/34 A61M39/06 A61F9/007

According to International Patent Classification (IPC) or to both national classification and IPC

B. FIELDS SEARCHED

Minimum documentation searched (classification system followed by classification symbols)
IPC 6 A61B A61M A61F

Documentation searched other than minimum documentation to the extent that such documents are included in the fields searched

Electronic data base consulted during the international search (name of data base and, where practical, search terms used)

C. DOCUMENTS CONSIDERED TO BE RELEVANT

Category *	Citation of document, with indication, where appropriate, of the relevant passages	Relevant to claim No.
A	US 4 795 426 A (JONES) 3 January 1989 cited in the application see the whole document ---	1
A	US 3 528 425 A (BANKO) 15 September 1970 see column 5, line 1 - column 6, line 40; figures 1-5 ---	1
A	EP 0 228 185 A (WHITE) 8 July 1987 see abstract; figures 1-5 see column 5, line 26 ---	1
A	DE 26 45 520 A (MCLAUGHLIN) 14 April 1977 see page 10, line 30 - page 16, line 7; figures 1-4 ---	1
	-/--	

Further documents are listed in the continuation of box C.

Patent family members are listed in annex.

* Special categories of cited documents :

- *A* document defining the general state of the art which is not considered to be of particular relevance
- *E* earlier document but published on or after the international filing date
- *L* document which may throw doubts on priority claim(s) or which is cited to establish the publication date of another citation or other special reason (as specified)
- *O* document referring to an oral disclosure, use, exhibition or other means
- *P* document published prior to the international filing date but later than the priority date claimed

- *T* later document published after the international filing date or priority date and not in conflict with the application but cited to understand the principle or theory underlying the invention
- *X* document of particular relevance; the claimed invention cannot be considered novel or cannot be considered to involve an inventive step when the document is taken alone
- *Y* document of particular relevance; the claimed invention cannot be considered to involve an inventive step when the document is combined with one or more other such documents, such combination being obvious to a person skilled in the art.
- *&* document member of the same patent family

Date of the actual completion of the international search

10 September 1997

Date of mailing of the international search report

18. 09. 97

Name and mailing address of the ISA

European Patent Office, P.B. 5818 Patentlaan 2
NL - 2280 HV Rijswijk
Tel. (+ 31-70) 340-2040, Tx. 31 651 epo nl,
Fax (+ 31-70) 340-3016

Authorized officer

Giménez Burgos, R

INTERNATIONAL SEARCH REPORT

Interr. Patent Application No
PCT/IL 97/00171

C.(Continuation) DOCUMENTS CONSIDERED TO BE RELEVANT

Category *	Citation of document, with indication, where appropriate, of the relevant passages	Relevant to claim No.
A	US 5 242 412 A (BLAKE, III) 7 September 1993 see the whole document -----	1

INTERNATIONAL SEARCH REPORT

Information on patent family members

International Application No

PCT/IL 97/00171

Patent document cited in search report	Publication date	Patent family member(s)	Publication date
US 4795426 A	03-01-89	NONE	
US 3528425 A	15-09-70	US 3659607 A	02-05-72
		US 3732858 A	15-05-73
EP 0228185 A	08-07-87	US 4729761 A	08-03-88
		CA 1284076 A	14-05-91
		JP 62224371 A	02-10-87
		US 4781675 A	01-11-88
DE 2645520 A	14-04-77	US 4096860 A	27-06-78
		BE 846907 A	31-01-77
		FR 2343487 A	07-10-77
		GB 1566564 A	08-05-80
		JP 1325279 C	16-07-86
		JP 52064191 A	27-05-77
		JP 60027538 B	29-06-85
		NL 7610957 A,B,	13-04-77
US 5242412 A	07-09-93	NONE	