

L. D. Snook.

Mower.

N^o 78490

Patented Jun. 2, 1868.

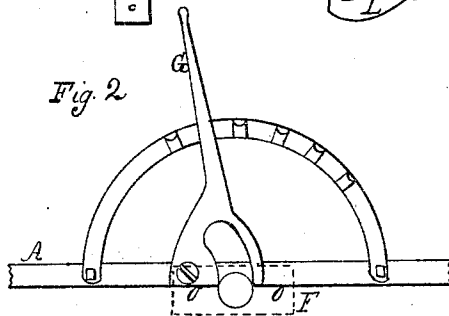
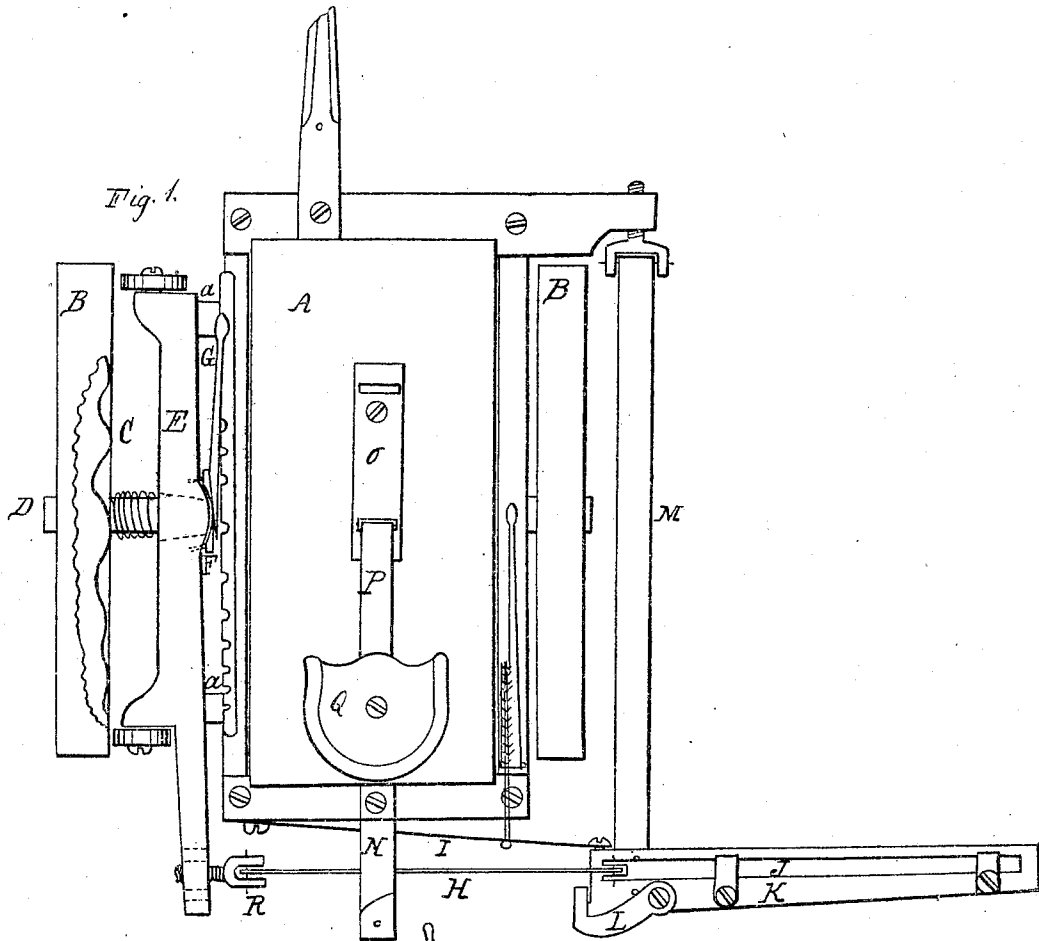

Witnesses
John L. Lewis
Charles Ketchum

Inventor
Lorenzo D. Snook

United States Patent Office.

LORENZO D. SNOOK, OF BARRINGTON, NEW YORK.

Letters Patent No. 78,490, dated June 2, 1868.

IMPROVEMENT IN HARVESTERS.

The Schedule referred to in these Letters Patent and making part of the same.

TO ALL WHOM IT MAY CONCERN:

Be it known that I, LORENZO D. SNOOK, of Barrington, in the county of Yates, and State of New York, have invented a new and useful Improvement in Reapers and Mowers; and I do hereby declare that the following is a full, clear, and exact description of the construction and operation of the same, reference being had to the annexed drawings, making a part of this specification, in which—

Figure 1 is a bird's-eye view,

Figure 2 is a sectional view of a part of the frame, fulcrum-plate, and forked lever, and means for holding it in proper position.

The letters of reference refer to the same parts in each figure.

The nature of my invention consists in making reapers and mowers without cog-wheels, and giving motion to the cutters by means of a cam-wheel within the felloe of one of the supporting-wheels, and a vibrating-lever that is connected to the cutter-bar by a connecting-rod, and having a finger-bar that may be raised or lowered at will, and folded for convenient transportation.

To enable others skilled in the art to make and use my invention, I will proceed to describe its mode of construction and operation.

A is the framework, that is used to connect and support the several parts of mechanism; it is supported by the axle D, and is held to it by journal-boxes, and is represented in fig. 1.

B and B are the supporting-wheels. The wheel on the right side is made to revolve upon the axle, and may be connected by ratchet and pawl, so that it can be used for a driving-wheel, or assistant driving-wheel. The left wheel is securely fastened to the axle, and is provided with a cam-wheel within the felloe, and attached to or made with it.

C is the cam-wheel, within the felloe of the driving-wheel B; it is shown in fig. 1, by the removal of a portion of the felloe, as represented by a zigzag line. The number of cams in the wheel must be according to the number of vibrations required of the lever E.

D is the axle; it must be stronger than for other reapers, to withstand the action produced by the cams; it is securely fastened in the left driving or supporting-wheel, and is provided with a collar, securely fastened to it, at a proper distance from the wheel, to allow the lever E and other necessary parts between it and the wheel.

E is a vibrating-lever; it may be made of any material, as wood or iron. Its use is to actuate the cutter-bar, and it must be of sufficient strength to withstand the influence of the cam-wheel, and impart motion to the cutter-bar. It is provided with anti-friction wheels, one at each end, as shown in fig. 1. It is supported by the axle D and the supports *a* and *a*. The hole through it must be made to allow it to vibrate, and in the middle and on the side toward the frame is a fulcrum that rests against the plate F, by which it is pushed toward the driving-wheel. It is pushed from the driving-wheel by a spring, that is used to throw it out of gear. At the ends, it is supported by the supports *a* and *a*. It is provided with an arm that extends from the rear end far enough for the end to be in line with the cutter-bar. The rear end of the arm is provided with a series of holes, or any equivalent device, that will hold the end of the connection H at any required distance from the fulcrum of the lever.

F is a plate, for the fulcrum of the lever E to rest against; it is made with a hole in the middle for the axle D to pass through; it is put on the axle, and is prevented from being turned, with a pin at each end, that extends into the lever E.

G is a forked lever, that is used to throw the lever E toward the driving-wheel; it is made as represented in fig. 2; it is pivoted to the frame A. The fork is made to pass over the axle, and each of these parts is made wedge-shaped, so that when the upper end is pulled backward, the wedge parts will pass downward between the collar on the axle and the plate F, and thereby put the lever E in gear with the cam-wheel. This lever is

held in position by notches, in a semicircular-shaped iron, that has each end fastened to the frame A, as shown in fig. 2.

H is the connection between the cutter-bar and the end of the arm of the lever E; it is united to the lever by part of a universal coupling, R, or any equivalent device, so that it may be adjusted to the proper position and motion for the cutter-bar.

I is a bracing-connection. One end is pivoted to the rear end of the frame, as near in line with the joint at the end of the connection H as convenient. The other end is pivoted to the finger-bar, so that its length may be near the length of the connection H.

J is the cutter-bar, with nothing peculiar in its construction.

K is the finger-bar; it is made in any ordinary manner, and is securely fastened to the rear end of the draught-bar M.

L is a hook; it is represented in fig. 1; it is pivoted to the finger-bar, so that it may be hooked around the end of the cutter-bar. Its use is to prevent the cutter-bar getting out of place when the finger-bar is turned up for transportation.

M is a draught-bar. The forward end is fastened to the forward piece of the frame, as represented in fig. 1. The rear end is securely fastened to the finger-bar. The forward end must be held by a turning or universal joint that will allow the outer end of the finger-bar to be raised up and turned over upon the support N, for convenient transportation.

N is a support for the finger-bar; it is securely fastened to the rear end of the frame A, and is provided with a pin, to keep the finger-bar upon it. Its use is to sustain the finger-bar when it is turned over for transportation.

O is a plate of iron, securely fastened to the frame A. Its use is to hold the spring that supports the driver's seat. It is made with a rib or flange at each edge, that prevents the spring from turning, and it is provided with a series of holes for the lower end of the spring to be put into, for the purpose of changing the seat back or forward, to properly balance the machine.

P is the spring that supports the driver's seat. The lower end is made to enter the plate O, and extend forward under the plate, while the forward part, immediately above the plate, rests upon it, and between the flanges. The rear end extends backward and upward, to any required distance, to hold the seat where desired.

Q is the seat; it may be made in any ordinary manner, and it is fastened upon the upper end of the spring P.

Having thus fully described my invention, what I claim as new, and desire to secure by Letters Patent, is—

1. The construction and arrangement of the lever E, provided with the anti-friction wheels and arm, with the plate F, and forked wedge-shaped lever G, when applied and actuated as and for the purpose set forth.

2. The laterally-adjustable coupling R, in combination with the connection H, when made and used as and for the purpose specified.

3. The hook L, when made and applied to keep the cutter-bar in place, substantially as specified.

LORENZO D. SNOOK.

Witnesses:

JOHN L. LEWIS,
CHARLES KETCHUM.