

M. HORST.
AUTOMATIC CAGE REST.

(Application filed Mar. 1, 1900.)

(No Model.)

2 Sheets—Sheet 1.

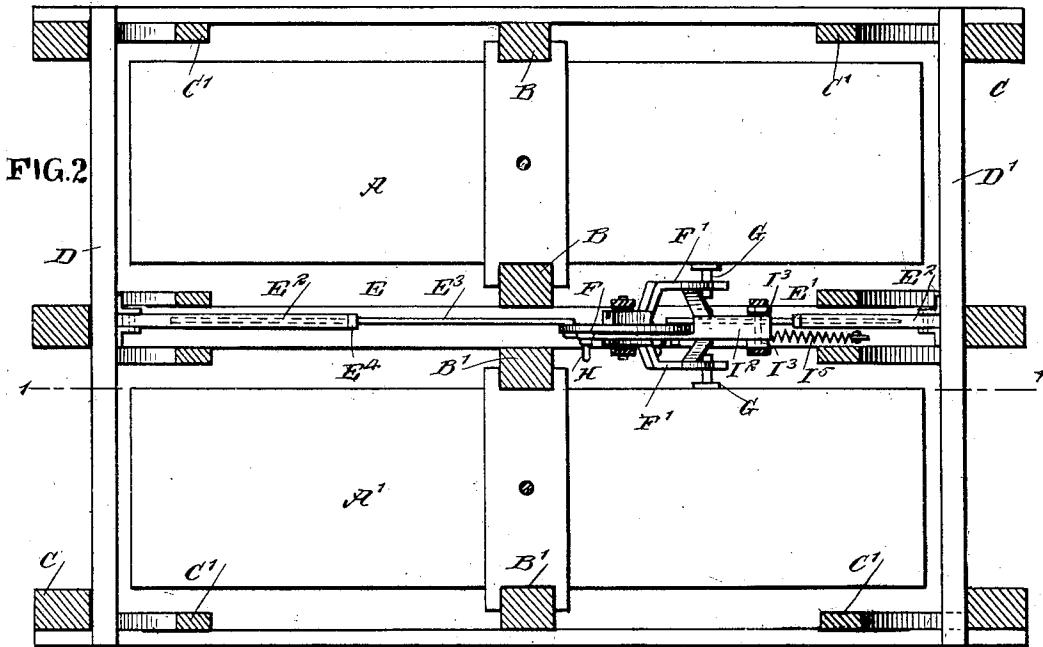
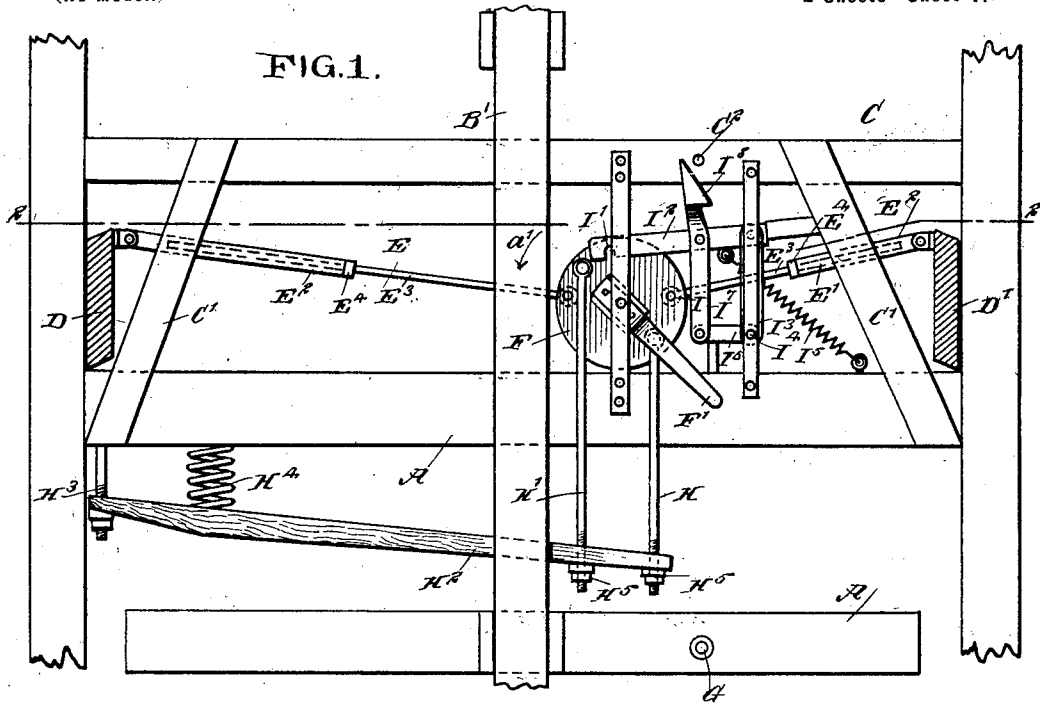

WITNESSES:

Donn Mitchell
Wm. G. Horst

INVENTOR

Martin Horst

BY

Mundy

ATTORNEYS

M. HORST.
AUTOMATIC CAGE REST.

(Application filed Mar. 1, 1900.)

(No Model.)

2 Sheets—Sheet 2.

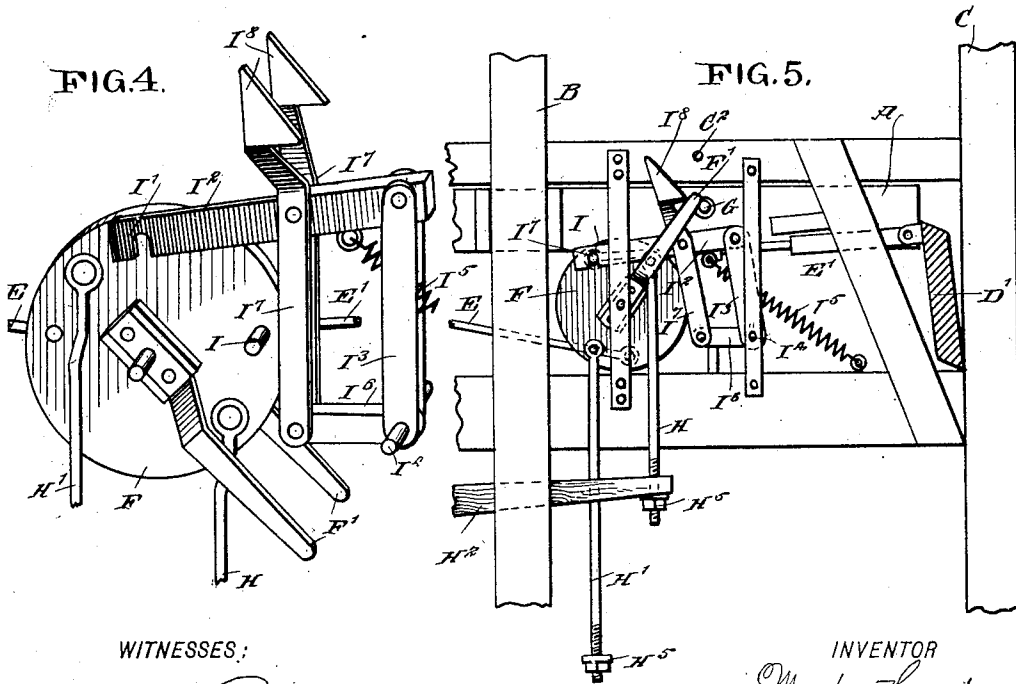
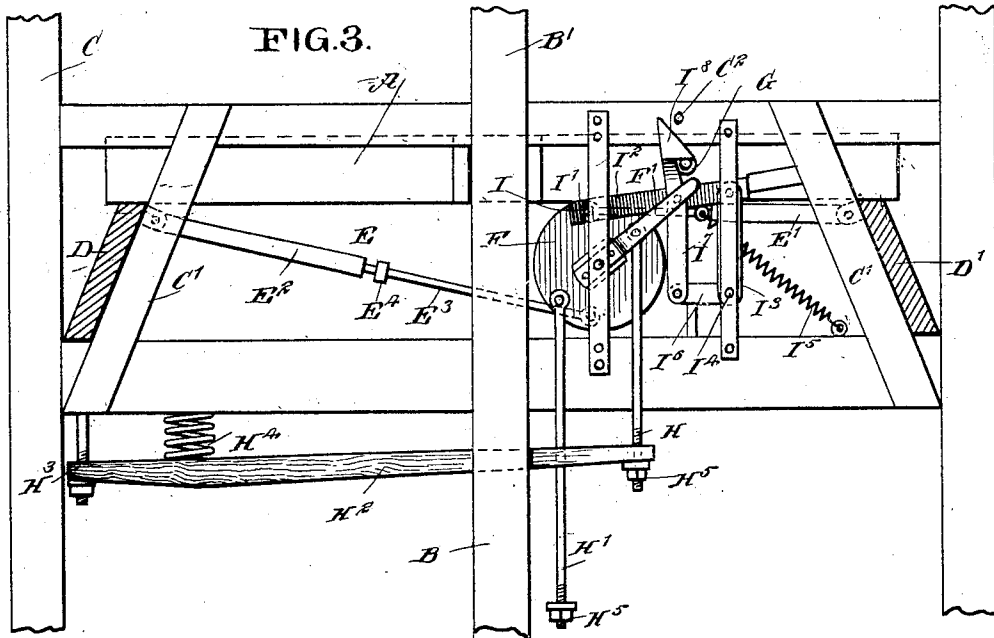

WITNESSES:

Edwin Litchell
Wm. G. Horst

INVENTOR

Martin Horst
BY *[Signature]*
ATTORNEYS

UNITED STATES PATENT OFFICE.

MARTIN HORST, OF NORTH LAWRENCE, OHIO.

AUTOMATIC CAGE-REST.

SPECIFICATION forming part of Letters Patent No. 659,970, dated October 16, 1900.

Application filed March 1, 1900. Serial No. 6,935. (No model.)

To all whom it may concern:

Be it known that I, MARTIN HORST, a citizen of the United States, and a resident of North Lawrence, in the county of Stark and State of Ohio, have invented a new and Improved Automatic Cage-Rest, of which the following is a full, clear, and exact description.

The invention relates to hoisting-machines used in mines and other places; and its object is to provide a new and improved cage-rest which is simple and durable in construction and automatic in operation, moving instantly into an active position to safely support the cage when the latter reaches the top of the shaft or mine.

The invention consists of novel features and parts and combinations of the same, as will be fully described hereinafter and then pointed out in the claims.

A practical embodiment of my invention is represented in the accompanying drawings, forming a part of this specification, in which similar characters of reference indicate corresponding parts in all the views.

Figure 1 is a sectional side elevation of the improvement as applied and with the cage below the rest, the section being taken on the line 1 1 in Fig. 2. Fig. 2 is a sectional plan view of the same on the line 2 2 in Fig. 1.

Fig. 3 is a sectional side elevation of the same with the parts in a different position and the cage at rest on the supports. Fig. 4 is an enlarged perspective view of the engaging and releasing mechanism for the wings or supports, and Fig. 5 is a sectional side elevation of the improvement as applied and with the parts in position at the time the cage rises to a final position and immediately before the supports swing into position for sustaining the cage.

The improvement illustrated in the drawings is applied to hoisting machinery for a mine, having two cages A A', mounted to alternately travel up and down in the mine on suitable guideways B B', forming part of the framework C, it being understood that the two cages are connected by a hoisting rope or cable with the hoisting-drum in such a manner that when the latter is rotated one of the cages ascends while the other descends. When a cage moves into an uppermost position on the top of the mine, it is adapted to rest on supports D D', extending transversely in the form of wings or fans, adapted to swing into a closed position by their own gravity against beams C', forming part of the framework C. (See Fig. 3.) Normally, however, the supports D D' stand in an open position, as illustrated in Figs. 1 and 5, to allow the cage to ascend or to descend.

The supports D D' are allowed to move into a closed position by a means controlled by the one of the cages which is traveling upward as the latter passes into its uppermost position, and said supports are moved into an open position by a spring-controlled device adapted to be released by the cage when the latter is moved upward from the supports previous to allowing the cage to descend to the bottom of the mine for the purpose described. The wings or supports D D' are connected by links E E', respectively, with a disk F, mounted to turn in suitable bearings attached to the framework C.

The connecting-points of the links E E' are located diametrically opposite each other on said disk F, as is plainly shown in the drawings, and on said disk are secured arms F', extending radially, one adapted to be engaged by a projection G, extending from the side of one of the cages, and the other by a projection G from the side of the other cage, so that when a cage moves into its uppermost position said projection engages the corresponding arm F' and imparts a swinging motion to the same to turn the disk F from the position shown in Fig. 1 into the position shown in Fig. 3, so as to allow the supports D D' to swing inward against the beams C C'—that is, into a closed position under the cage A—so as to support the same while in an uppermost position.

The disk F is provided with depending links H H', engaging a lever H², fulcrumed at H³ on the framework C and pressed on in a downward direction by a heavy spring H⁴. The links H H' pass loosely through the free end of the lever H² and are adapted to engage with washers and nuts H⁵ on the under side of the said lever, so that when the disk F is turned from the position shown in Fig. 1 one of the links is pressed on at a time by the

The improvement illustrated in the drawings is applied to hoisting machinery for a mine, having two cages A A', mounted to alternately travel up and down in the mine on suitable guideways B B', forming part of the framework C, it being understood that the two cages are connected by a hoisting rope or cable with the hoisting-drum in such a manner that when the latter is rotated one of the cages ascends while the other descends. When a cage moves into an uppermost position

spring-pressed lever H^2 , while the other link extends loosely through the lever, as shown in Figs. 3 and 5.

In order to lock the disk F against the tension of the spring-pressed lever H^2 , said disk is provided with a pin I , adapted to engage a notch I' , formed in the free end of an arm I^2 , fulcrumed on the upper end of an arm I^3 , pivoted at I^4 to the framework C , a spring I^5 pulling on the arm I^3 in a downward direction. On the pivot I^4 is fixed an arm I^6 , on which are pivoted releasing-levers I^7 , pivotally connected with an arm I^2 and formed at their upper ends with hooks I^8 , adapted to be engaged by the projections G of the cages A and A' , respectively.

The wedge-shaped free ends of the hooks I^8 are adapted to travel on fixed pins C^2 , carried by the framework C , so as to swing said levers I^7 to the left, as will be readily understood by reference to Fig. 3. (See also Fig. 5.) The links E and E' , previously mentioned, are preferably each made in two parts E^2 and E^3 , of which the part E^2 is tubular and receives the end of the other part E^3 for the latter to slide therein, the part E^3 having a collar E^4 abutting against the inner end of the part E^2 , so as to push the support D or D' into an open position when the disk F moves to the position shown in Fig. 1.

The operation is as follows: When the several parts are in the position shown in Fig. 1 and the cage A ascends and when nearing the top of the mine moves with its projection G in engagement with the arm F' , then the disk F is turned in the direction of the arrow a' , whereby the link H imparts an upward-swinging motion to the lever H^2 to compress the spring H^4 . The turning of the disk F causes an inward movement of the links E and E' , so as to allow the supports D and D' to swing by their own gravity into a closed position, as shown in Fig. 3, at the time the cage A is moved above the said supports. When this takes place, the pin I moves in engagement with the notch I' , so as to lock the disk F against a return movement by the action of the lever H^2 and link H . At this time the projection G has passed the free end of the arm F' and has moved under the hook I^8 of the corresponding lever I^7 , as shown in Fig. 3. The cage now rests on the supports D and D' , and the car of the cage is run off and another one is substituted, and when it is desired to again lower the cage into the mine then the hoisting-drum is rotated to cause a slight rising of the cage A , whereby the projection G imparts an upward movement to the lever I^7 , and as the same is connected with the arm I^2 the latter is swung upward and its notch I' is disengaged from the pin I , so that the disk F is unlocked and the spring H^4 , by pressing on the lever H^2 , causes the latter and the link H to pull the disk F back into its former position, (shown in Fig. 1,) and at the same time the lever I^7 is swung to the left by coming in contact with the fixed pin C^2 , so that the hook I^8 is disen-

gaged from the projection G . While the cage A is thus lifted a short distance above the supports D and D' and the disk F is caused to return to the position shown in Fig. 1, it is evident that the links E and E' impart an outward-swinging motion to the supports D and D' , so as to move the same into an open position to allow the cage A to freely descend, which now takes place by the engineer reversing the movement of the hoisting-drum.

From the foregoing it is understood that the several parts of the device are moved back into a normal position—that is, with the supports D and D' open during the time one cage descends and the other ascends—and when a cage moves into an extreme uppermost position then it actuates the arm F' , as previously described, for allowing the supports D and D' to move into a closed position.

Having thus fully described my invention, I claim as new and desire to secure by Letters Patent—

1. A cage-rest, comprising supports for the cage, and means controlled by the cage and connected with the said supports, to hold the latter normally in an open position for the passage of the cage in its ascent, said supports immediately moving into a closed position when the cage has risen above the supports.

2. A cage-rest, comprising self-closing supports for the cage, means controlled by the cage and connected with the said supports, to hold the latter normally in an open position, and to allow the supports to close as soon as the cage has risen above the supports, and a releasing device for the said means and controlled by the cage, to allow the said means to again open the supports for the cage to descend, as set forth.

3. A cage-rest, comprising a spring-pressed arm mounted to turn and adapted to be engaged by a rising cage, and self-closing supports normally held in an open position from the said arm, and adapted to close upon the arm receiving a swinging motion from the cage, substantially as shown and described.

4. A cage-rest, comprising a spring-pressed arm mounted to turn and adapted to be engaged by a rising cage, self-closing supports normally held in an open position from the said arm, and adapted to close upon the arm receiving a swinging motion from the cage, and a locking device for locking the arm in an uppermost position after the supports have moved into a closed position, substantially as shown and described.

5. A cage-rest, comprising a spring-pressed arm mounted to turn and adapted to be engaged by a rising cage, self-closing supports normally held in an open position from the said arm, and adapted to close upon the arm receiving a swinging motion from the cage, and a locking device for locking the arm in an uppermost position after the supports have moved into a closed position, and a releasing device for the said locking device and con-

trolled by the cage, substantially as shown and described.

6. A cage-rest, comprising a disk mounted to turn, a spring-pressed lever connected by links with said disk, an arm on said disk and adapted to be engaged by a projection on the cage, links pivotally connected with said disk, and self-closing supports pivotally connected with said links, substantially as shown and described.

7. A cage-rest, comprising a disk mounted to turn, a spring-pressed lever connected by links with said disk, an arm on said disk and adapted to be engaged by a projection on the cage, links pivotally connected with said disk, self-closing supports pivotally connected with said links, and a locking device for said disk, and comprising a pin on the disk, and a spring-pressed arm having a notch engaging said pin, as set forth.

8. A cage-rest, comprising a disk mounted to turn, a spring-pressed lever connected by links with said disk, an arm on said disk and adapted to be engaged by a projection on the cage, links pivotally connected with said disk, self-closing supports pivotally connected with said links, and a locking device for said disk, and comprising a pin on the disk, a spring-pressed arm having a notch engaging said pin,

and a releasing device for the said locking device, and comprising a hook-lever connected with said notched arm, and adapted to be engaged by a projection on the cage, as set forth.

9. A cage-rest, comprising a disk mounted to turn, a spring-pressed lever connected by links with said disk, an arm on said disk and adapted to be engaged by a projection on the cage, links pivotally connected with said disk, self-closing supports pivotally connected with said links, a locking device for said disk, and comprising a pin on the disk, a spring-pressed arm having a notch engaging said pin, and a releasing device for the said locking device, and comprising a hook-lever connected with said notched arm, and adapted to be engaged by a projection on the cage, the said hook-lever being adapted to engage a fixed pin, to impart a swinging motion to the lever, as set forth.

In testimony whereof I have signed my name to this specification in the presence of two subscribing witnesses.

MARTIN HORST.

Witnesses:

JOHN E. JOHNS,
JACOB D. NETTER.