

A. E. Guyot,

Winding Watch.

No. 101,859.

Patented Apr. 12, 1870.

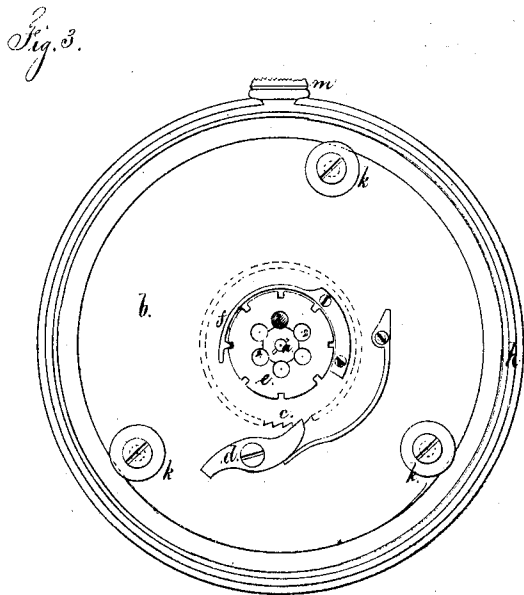
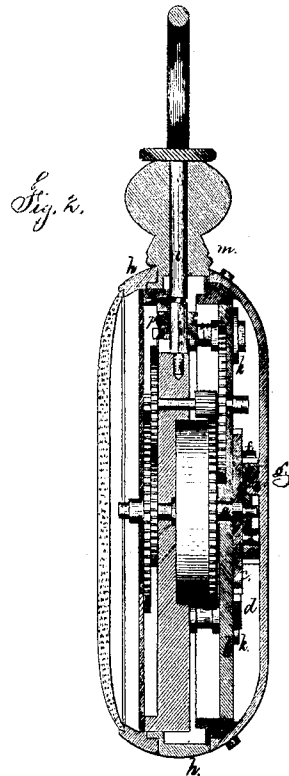
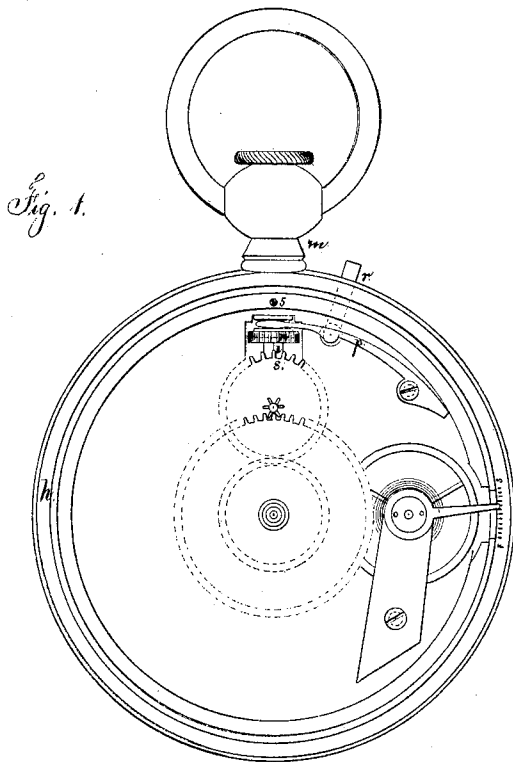

A. E. Guyot.

per L. M. Serrell atty.

Witnesses

Chas. H. Smith

Geo. W. Walker

United States Patent Office.

A. ETIENNE GUYOT, OF RENAU, SWITZERLAND.

Letters Patent No. 101,859, dated April 12, 1870.

IMPROVEMENT IN WINDING WATCHES.

The Schedule referred to in these Letters Patent and making part of the same.

To all whom it may concern :

Be it known that I, A. ETIENNE GUYOT, of Renau, in the canton of Bern, Switzerland, have invented an Improvement in Winding Watches, of which the following is declared to be a correct specification.

This invention relates to winding the watch by a motion derived from the rotation of the back of the case, whereby the opening of the case is rendered unnecessary, dust is excluded, sufficient power is easily obtained, and there are no small parts that are liable to be broken.

In the accompanying drawing—

Figure 1 represents the watch with the face removed;

Figure 2 is a vertical transverse section through the watch and pendant or shank; and

Figure 3 represents the back of the watch with the outer case removed.

The mainspring is in the middle of the watch, and its arbor *a* projects through the back-plate *b*, centrally of the watch, and receives the ratchet-wheel *c* that is retained by the pawl *d* as the watch is wound.

Upon the end of this arbor *a* is the winding-wheel *e*, that is connected to the ratchet-wheel *c* by the circular pawl *f*, that is attached at one end to this ratchet-wheel *c*, and provided with an inclined tooth near the other end, taking one of a series of notches around the edge of the wheel *e*.

In this winding-wheel *e* are holes or cavities 2 2, and the back-plate *g* of the watch is made with an inwardly-projecting stud, 3, that is eccentric to the case, so as to enter one of the holes 2 as the back *g* is applied to the watch.

The back *g* sits closely around the bezel *h*, to exclude the dust, but at the same time the back can be turned around freely, and friction-rollers or disks may be applied at *kkk*, to cause the back *g* to turn freely.

It is now to be understood that when the back *g* is turned the wheel *e* is revolved by the stud 3, and if it

moves in one direction it winds up the watch-spring while turning the ratchet-wheel *c*.

If the winding is not arrested when the proper number of turns have been given, the stopping of the arbor or the increased power of the spring causes the pawl *f* to slip out of one of the notches, so that nothing will be broken even if the movement is continued; otherwise, the back being large, and having leverage over the other parts, injury might result to some of them.

If the back is turned the other way, the pawl *f* runs freely over the edge of the winding-wheel *e*.

The arrangement of the train of wheels to the balance and to the hands may be of any desired character.

The setting-mechanism consists of a stud, *i*, passing through the pendant or shank *m*, and retained by a screw, 5, taking a collar or neck on the stud, but allowing it to turn freely.

Upon this stud *i* is a pinion, *n*, fitted to slide thereon by means of the spring *p* and push-pin *r*, so as to gear into the wheel *s* that moves the hands.

The spring *p* keeps the pinion *n* away from the wheel *s*, except when the pin *r* is pushed in.

This improvement dispenses with hinges to the case, keeps dust out of the works, and the winding and setting devices are always in place.

I claim as my invention—

1. The winding-wheel *e*, with the cavities 2 2, in combination with the back-plate *g* and inwardly-projecting stud 3, as and for the purposes specified.

2. The winding-wheel *e*, ratchet-wheel *c*, and pawls *f* and *d*, in combination with the revolving back *g* and stud 3, substantially as set forth.

In witness whereof I have set my signature this 16th day of October, A. D. 1869.

Witnesses:

A. ETIENNE GUYOT.

CHAS. H. UPTON,

CHAS. E. JACOB.