



(22) Date de dépôt/Filing Date: 2008/10/20

(41) Mise à la disp. pub./Open to Public Insp.: 2009/04/26

(45) Date de délivrance/Issue Date: 2011/09/20

(30) Priorité/Priority: 2007/10/26 (US11/925498)

(51) Cl.Int./Int.Cl. *E21B 33/04* (2006.01)

(72) Inventeurs/Inventors:

ROGERS, JOHN, US;
WILLARD, STEVE, US;
CAIN, BRANDON, US;
DAVIDSON, CARL, US;
BILYEU, MICHAEL, US;
TRAVIS, TODD, US;
ALTMAN, GORDON, US

(73) Propriétaire/Owner:

WEATHERFORD/LAMB, INC., US

(74) Agent: GOODWIN MCKAY

(54) Titre : ENSEMBLE POUR TETE DE PUITS CAPABLE DE PLUSIEURS CONFIGURATIONS

(54) Title: WELLHEAD COMPLETION ASSEMBLY CAPABLE OF VERSATILE ARRANGEMENTS

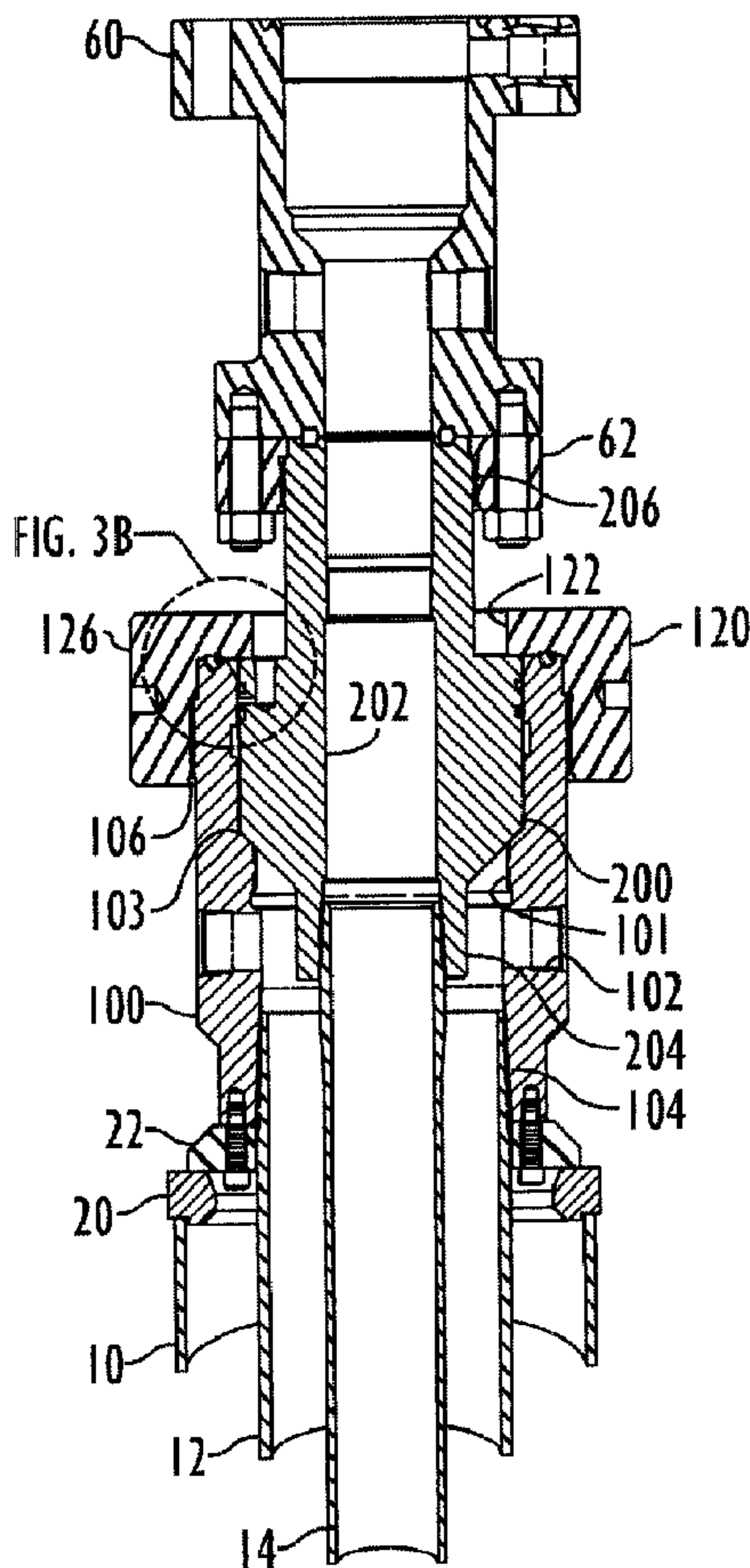

(57) Abrégé/Abstract:

A wellhead completion assembly has a head connected to surface casing. A rotatable flange or the like can be used to connect various components to a threaded end of the head. A casing hanger installs in the head, and the hanger's upper end extends

(57) **Abrégé(suite)/Abstract(continued):**

beyond the head's top edge. This exposed end has an external threaded connection to connect to various wellhead components using a rotatable flange or the like. For example, a locking ring can threadably connect to the head's threaded end to support the hanger in the head. Then, a rotatable flange can threadably connect to the hanger's exposed end so that another component, such as a completion spool or gate valve, can nipped up directly to the hanger. When the hanger is fluted, a pack-off assembly can allow testing off inner and outer sealing integrity via a test port accessible through an opening in the locking ring.

1
2
3
4
5
6
7
8
9
10
11
12

ABSTRACT

A wellhead completion assembly has a head connected to surface casing. A rotatable flange or the like can be used to connect various components to a threaded end of the head. A casing hanger installs in the head, and the hanger's upper end extends beyond the head's top edge. This exposed end has an external threaded connection to connect to various wellhead components using a rotatable flange or the like. For example, a locking ring can threadably connect to the head's threaded end to support the hanger in the head. Then, a rotatable flange can threadably connect to the hanger's exposed end so that another component, such as a completion spool or gate valve, can nipped up directly to the hanger. When the hanger is fluted, a pack-off assembly can allow testing off inner and outer sealing integrity via a test port accessible through an opening in the locking ring.

1 **WELLHEAD COMPLETION ASSEMBLY CAPABLE OF VERSATILE**
2 **ARRANGEMENTS**
3

4 BACKGROUND

5 A well has one or more casings installed in a borehole to reinforce and
6 seal it, and wellhead components install at the surface above the exposed end of
7 the casings. For example, FIG. 1 shows a wellhead arrangement according to the
8 prior art. Typically, an outermost conductor pipe is driven into place in the borehole,
9 and a base assembly 11 is on the exposed end of conductor pipe 10. A casing
10 head 30 lands on the base assembly 11 and connects to a surface casing 14
11 supported inside the conductor pipe 10. Typically, the space between the casing 14
12 and pipe 10 is filled with cement. One or more adapters 40 and components 50 of a
13 blow-out preventer can connect above the casing head 30. As shown in FIG. 1,
14 flanged connections are typically used to connect the various components together.

15 Because various operations may be performed at the wellhead, the
16 arrangement of components may be modified to accommodate different operations,
17 pressures, and implementations. One typical wellhead operation involves fracing.
18 According to conventional practices, an isolation tool, such as a stinger, installs in
19 the wellhead to isolate bores and outlets from pressures that may be higher than
20 pressure-ratings for the wellhead's flange connections.

21 In one typical wellhead arrangement, a casing hanger supports casing
22 in the casing head, and a tubing spool nipples to the casing head so that another
23 hanger can be used in the tubing spool to support tubing in the casing. Typically,
24 an adapter must be installed on the casing head prior to nipping up the tubing spool

1 so that the adapter can pack-off or seal around the casing hanger. In another
2 typical wellhead arrangement, a fluted casing hanger support casing in the casing
3 head so that drilling fluids during cementing operations are allowed to return
4 through the hanger's flutes. Later, a pack-off bushing installs above the fluted
5 casing hanger to seal off the flutes. Typically, there is only a limited ability to test
6 the seal created by such a pack-off.

7

8

BRIEF DESCRIPTION OF THE DRAWINGS

9 Figure 1 is a partial cross-sectional view illustrating a wellhead
10 arrangement according to the prior art;

11 Figure 2 is a cross-sectional view illustrating a wellhead completion
12 assembly in one arrangement having portion of a Blow-Out Preventer (BOP) stack
13 nipped up to a casing head;

14 Figure 3A is a cross-sectional view illustrating the assembly of FIG. 2
15 in another arrangement having a completion spool nipped up to the casing hanger;

16 Figure 3B is a detail illustrating portions of the casing hanger, the
17 locking ring, and the casing head of FIG. 3A;

18 Figure 4 is a cross-sectional view illustrating the assembly of FIG. 2 in
19 yet another arrangement having a gate valve nipped up to the casing hanger;

20 Figures 5A-5B are top and cross-sectional views illustrating a fluted
21 casing hanger for the disclosed assembly;

22 Figure 6 is a cross-sectional view illustrating a pack-off plate;

1 Figure 7A is a partial cross-sectional view illustrating a flange and the
2 pack-off components on the fluted casing hanger of FIGS. 5A-5B;

3 Figure 7B is a detail of FIG. 7A illustrating features of the pack-off
4 components;

5 Figure 8 is a cross-sectional view illustrating the casing head of FIG. 2
6 landed through a riser;

7 Figures 9A-9B are cross-sectional views illustrating the casing head of
8 FIG. 2 used with other wellhead components;

9 Figure 10A is a cross-sectional view illustrating another embodiment
10 of a wellhead completion assembly in one arrangement;

11 Figure 10B is a cross-sectional view illustrating the assembly of FIG.
12 10A in another arrangement;

13 Figures 11A-11D are cross-sectional views illustrating a wellhead
14 completion assembly having modular head components in various stages of
15 assembly;

16 Figures 12A-12B are cross-sectional views illustrating the modular
17 assembly using only a first head component;

18 Figure 13 is a cross-sectional view illustrating the modular assembly
19 using three head components;

20 Figures 14A-14C are cross-sectional views illustrating the modular
21 assembly when stuck pipe occurs; and

22 Figures 15A-15C are cross-sectional views illustrating the modular
23 assembly having a control line when stuck pipe occurs.

1

2

DETAILED DESCRIPTION

3

4

5

6

7

8

9

A versatile wellhead completion assembly is capable of various arrangements. The assembly includes a casing head that lands on a conductor pipe and connects to surface casing. The head's upper end has an external threaded connection to which various components can be connected depending on the desired arrangement. For example, a rotatable flange or other connector can thread onto the head's upper end, and a component of a blow-out preventer (BOP) can bolt to the rotatable flange above the casing head.

10

11

12

13

14

15

16

17

18

19

The assembly also includes a casing hanger that lands in the casing head to support production casing within the surface casing. When installed in the head, the hanger's upper end extends beyond the head's top edge. This exposed end has an external threaded connection that allows various components to connect to the hanger's upper end depending on the desired arrangement. For example, a locking ring can threadably connect to the head's external threaded connection to support the casing hanger in the casing head. Then, a rotatable flange or other connector can threadably connect to the hanger's exposed end so that a completion spool, gate valve, or other wellhead component can bolt to the rotatable flange above the casing hanger.

20

21

22

23

In other arrangements, the casing head can be used with conventional wellhead components and can be landed through a riser using a running tool threaded to internal threads in the casing head. In addition, the casing hanger used in the various arrangements can be fluted, and a pack-off assembly that allows

1 testing of inner and outer seals can be used with the fluted casing hanger. In still
2 other arrangements, modular head components of the assembly permit operators to
3 make various arrangements of the head components to suit their needs in either
4 single-bowl or multiple-bowl arrangements and to facilitate contingency operations
5 in the event a stuck pipe occurs.

6 Turning now to the drawings, FIG. 2 illustrates a well completion
7 assembly having a casing head 100 and a casing hanger 200. The casing head
8 100 with a landing ring 22 attached thereto lands on a support ring 20 on an
9 exposed end of conductor pipe 10, and an internal threaded connection 104
10 connects to surface casing 12. Side ports 102 for valves or the like are provided in
11 the head's bore 101 for various uses during well operations. When the casing head
12 100 is installed as shown, flutes (not shown) in the rings 20/22 can allow cement to
13 be inserted between the conductor pipe 10 and the surface casing 12 during a
14 cementing job.

15 In the arrangement, a rotatable flange 110 threadably connects to an
16 external threaded connection 106 on the casing head's upper end, and a BOP stack
17 component 50 nipples up to the casing head 100 by bolting to the flange 110. To
18 seal this connection, a gasket is disposed in a groove at head's top edge. Rather
19 than using the rotatable flange 110 as shown, a drilling adapter, such as element
20 530 shown in FIG. 10A, or other connector could alternatively be used.

21 Also in the arrangement, the casing hanger 200 has production casing
22 14 connected by an internal threaded connection 204 at the hanger's lower end. To
23 install the hanger 200 and the casing 14, a running tool 52 connects by a coupling

1 54 to an external threaded connection 206 at the hanger's upper end, and the
2 hanger 200 and the casing 14 are run through the BOP stack component 50 and
3 into the casing head 100. Once run in, the casing hanger 200 lands in the head 10
4 by engaging an internal shoulder 103 so that the production casing 14 is supported
5 within the surface casing 12.

6 As will be appreciated, each of the components of the assembly is
7 composed of a suitable material known in the art for a wellhead component.
8 Preferably, the threaded connections (106, 204, and 206) have ACME-2G left-
9 handed thread forms. For some exemplary dimensions, the conductor pipe 10 may
10 be 16-in. casing, and the surface and production casings 12/14 may respectively be
11 9 5/8-in. and 4 1/2-in. casings. The connection of the rotatable flange 110 to the
12 BOP stack component 50 may be 11-in. rated at a working pressure of 5,000-PSI.
13 As one skilled in the art will appreciate, these values are provided as examples for
14 illustrative purposes, and components of the assembly can be sized for 13-inch
15 connections and other sizes of casing.

16 During operations, it would be desirable to be able to nipple up a
17 tubing spool above a production casing hanger without requiring the use of
18 secondary pack-off to seal around the hanger. As shown in FIG. 3A, the disclosed
19 assembly allows a completion spool 60 to nipple up to the casing hanger 200 of the
20 disclosed assembly without the need for secondary pack-off. In this arrangement, a
21 locking ring 120 defining a central opening 122 installs over the hanger's end
22 exposed above the head 100, and internal threads on the ring's sides 126 couple to
23 the external threaded connection 106 on the casing head 100. This connection 106

1 can be 11-in. rated at a working pressure of 10,000-PSI. As shown in the detail of
2 FIG. 3B, the ring's inside surface 124 engages the hanger's upper shoulder 207 to
3 hold the hanger 100 in the head 100. Also, the inside surface 122 engages a
4 gasket 108 disposed in a groove at the head's top edge.

5 With the ring 120 installed, the tubing spool 60 can couple directly to
6 the exposed end of the hanger 200. In particular, a rotatable flange 62 or other
7 connector threads onto the hanger's external threaded connection 206, and the
8 spool 60 bolts to the rotatable flange 62. A gasket is disposed in a groove at the
9 hanger's top edge to seal the connection. This connection between hanger 200 and
10 spool 60 can be 4 1/16-in. rated at a working pressure of 10,000-PSI, for example.
11 With the spool 60 connected, other components can then be connected above the
12 spool 60, and tubing (not shown) can eventually be hung in the spool's bowl using a
13 tubing hanger (not shown). Because the completion spool 60 nipples up directly to
14 the hanger 200, the casing hanger 200 essentially acts as a spool, and the need for
15 secondary pack-off is eliminated.

16 As shown in detail in FIG. 3B, the hanger's upper shoulder 207
17 defines a test port 208 that communicates between two sealing seats 209 disposed
18 about the hanger's outer cylindrical surface. With the hanger 200 installed in the
19 head's internal bore 101 as shown, this test port 208 is accessible through the ring's
20 opening 122 so that the seal formed between the sealing seats 209 and the casing
21 head's internal bore 101 can be tested.

22 FIG. 4 shows a similar arrangement with a gate valve 65 nipple up to
23 the casing hanger 200 of the assembly. Again, the rotatable flange 62 couples to

1 the external threaded connection 206 on the exposed end of the hanger 200, and
2 the gate valve 65 bolts to the flange 62. As will be appreciated, the gate valve 65
3 may be used for fracing operations or the like. With respect to frac operations, it
4 would be desirable to be able to frac at high pressures without needing to use an
5 isolation tool in the wellhead. In current arrangement of the disclosed assembly,
6 there is no need to use an isolation tool (or a nipple up/down apparatus for such an
7 operation). Rather, interior frac pressures can reach as high as the internal yield
8 pressure of the production casing 14 itself because the housing of the casing 14
9 communicates directly with the gate valve 65 through the casing hanger 200.
10 Therefore, frac pressures that can be used with the disclosed assembly are not
11 limited by conventional flange pressure ratings of adapters or the like that would
12 typically be used above a production casing hanger.

13 The hanger 200 shown in FIG. 4 has flutes that allow fluid returns past
14 the hanger 200 when used in some arrangements. In FIG. 4, however, a pack-off
15 assembly 210 having a pack-off plate and other components forms a seal between
16 the fluted hanger 200 and the inside surface of locking ring 120. When this form of
17 pack-off is done, it is desirable to have an adequate and convenient way to test the
18 pack-off's inner and outer seals. In the prior art, however, the only way to test the
19 integrity of a pack-off's seals requires operators to nipple up the next spool above
20 the pack-off assembly and to then perform a flange pressure test. For example,
21 FIG. 9A discussed below shows a conventional pack-off plate 74 having an inner
22 seal that engages casing 14 and having an outer seal that engages casing head
23 100. To test the seals, a tubing spool 70 must be nipped up to the casing head

1 100, and a flange pressure test must be performed using a test port 73 on the spool
2 70. If the test fails, operators have to nipple down the spool 70 and pull out the
3 pack-off plate 74 to investigate the cause. This procedure can be time intensive.

4 In contrast, the pack-off assembly 210 in FIG. 4 has a top-access test
5 port 212 accessible through the sealing ring's opening 122. This test port 212
6 communicates between two sets of inner and outer seals on the assembly 210. In
7 this way, the sealing integrity of the assembly's inner and outer seals can be tested
8 simultaneously and as soon as the assembly 210 is installed so that time can be
9 saved on site. Further details of a fluted hanger and a pack-off assembly are
10 discussed below with reference to FIGS. 5A through 8C.

11 FIGS. 5A-5B illustrate a fluted casing hanger 300 for use with the
12 disclosed assembly in top and cross-sectional views, respectively. As with other
13 hangers disclosed herein, the fluted hanger 300 has an internal bore 302 with an
14 internal threaded connection 303 at its lower end to connect to production casing
15 (not shown). In addition, the hanger's upper end has an external threaded
16 connection 306 for coupling to running tool as in FIG. 2 or to a rotatable flange as in
17 FIG. 3A. Furthermore, the hanger's top edge defines an annular well 308 for a
18 gasket (not shown) used to seal engagement between the hanger 300 and the
19 various other components discussed herein.

20 Being fluted, however, the hanger's lower end defines a plurality of
21 flutes or cutaways 304 (four shown in FIG. 5A) that enable fluid returns to
22 communicate past the hanger 300. In another distinction, the hanger 300 as shown
23 in FIG. 5B has a blunt or flat lower end as opposed to the substantially extended

1 and narrowed lower end of the other hangers disclosed herein. It will be
2 appreciated that any of the other hangers (either fluted or not) disclosed herein may
3 have a similar blunt end if desired.

4 As briefly discussed above in FIG. 4, a pack-off assembly 210 can be
5 used to seal communication through flutes of a fluted hanger when returns are no
6 longer desired. When used, the pack-off assembly 210 preferably allows the
7 sealing integrity of inner and outer seals to be tested in an adequate and convenient
8 way. For such as a pack-off assembly, FIG. 6 illustrates a pack-off plate or sealing
9 ring 400 capable of such testing ability, and FIGS. 7A-7B illustrate the pack-off plate
10 400 and an additional sealing ring 430 positioned on the fluted casing hanger 300 of
11 FIGS. 5A-5B.

12 As best shown in FIGS. 7A-7B, the sealing ring 430 positions adjacent
13 a lowermost shoulder 309a on the hanger 300. The pack-off plate 400 (shown in
14 cross-section in FIG. 6) has a central opening 402 and positions over the hanger's
15 narrower end and threads its internal threads 407 onto intermediate threaded
16 connection 307 on the hanger 300. This pack-off plate 400 may be referred to as a
17 production casing hanger pack-off or an H-plate.

18 As the pack-off plate 400 is tightened onto the hanger 300, internal
19 seals 450 (e.g., O-rings) on the pack-off plate 400 eventually engage a side portion
20 309b of the hanger's surface, while outer seals 440 (e.g., O-rings) engage the
21 internal wall of the casing head's bore (not shown). Likewise, the plate's lower lip
22 404 wedges in between the lowermost ring 430 and a side portion 309b of the

1 hanger's surface so that the lowermost ring 430 seals against the internal wall of the
2 casing head's bore (not shown).

3 To test the sealing integrity, the pack-off plate 400 defines a test port
4 406 in its top surface 405 that is accessible when the locking ring (e.g., 120 in FIG.
5 4) is used. As best shown in the cross-section of the plate 400 in FIG. 6, the test
6 port 406 communicates with spaces between the outer and inner seats 408/409 for
7 the seals (440/450) so that their sealing integrity can be tested. Because this test
8 port 406 is accessible through the locking ring's opening (122), this testing can be
9 done during partial assembly of the pack-off or after complete assembly of the
10 arrangement.

11 In addition to being used with the casing hanger 200, pack-off
12 assembly 210, and other components discussed above, the casing head 100 can
13 be used on its own with various other wellhead components in a number of other
14 arrangements. In one example shown in FIG. 8, the casing head 100 can be run
15 through a riser 16 and landed on a support ring 20 using an internal running tool 18.
16 To run the head 100, the internal running tool 18 has a coupling 19 that attaches to
17 an internal threaded connection 107 in the casing head's bore 101.

18 In other uses, the casing head 100 can also be used on its own in
19 conjunction with some conventional wellhead components. For example, FIG. 9A
20 shows the casing head 110 having a completion spool 70 nipped up to the head
21 100 with a rotatable flange 110. FIG. 9B shows a similar arrangement, but in this
22 example, a completion spool 80 and adapter 82 nipple up to the casing head 100
23 with a rotatable flange 110.

1 In both arrangements, a conventional hanger 76 having slips 77 lands
2 on the head's internal shoulder 103 to support the production casing 14, and a
3 conventional pack-off plate 74 seals against the production casing 14 and the head
4 100. Segmented rings 72 engage against the production casing 14 within the spool
5 70 in FIG. 9A, while internal seals in the adapter 82 engage against the end of
6 production casing 14 in FIG. 9B.

7 The casing head 100 disclosed above represents a single-bowl type,
8 meaning that it defines a single bowl and has a length for supporting a single
9 hanger. FIGS. 10A-10B illustrates a wellhead completion assembly having a casing
10 head 500 that represents a double-bowl type. Accordingly, one casing hanger 510
11 (FIG. 10A) or two casing hangers 510/540 (FIG. 10B) can be used with this casing
12 head 500. Although shown as fluted, the casing hangers 510/540 could be mandrel
13 hangers, if desired.

14 In the arrangement of FIG. 10A, a BOP stack component 50 nipples
15 up to the casing head 500. In this example, the connection uses a drilling adapter
16 530 that has a locking assembly 532 for quick connect to the casing head 500,
17 pack-off screws 534 for other purposes, and a flange 536 for bolting to the BOP
18 stack component 50. The casing hanger 510 lands in the casing head 500 through
19 the BOP stack component 50 using a running tool (not shown). A pack off
20 assembly 520 having pack-off elements 522 installs above the casing hanger 510,
21 and pack-off screws 524 on the head 500 engage the elements 522. Once
22 installed, the pack-off assembly 520 forms an additional bowl in the head 500. In

1 this example, the conductor pipe 10 can be 20-in. casing, and the surface casing 12
2 can be 9 5/8-in casing. The casing hanger 510 can support 7-in. production casing.

3 In the arrangement of FIG. 10B, the casing hanger 510 and the pack-
4 off assembly 520 again install in the casing head 500, and a fluted hanger 540 and
5 pack off assembly 545 install in the end of the casing head 500. A locking ring 550
6 threads onto the end of the casing head 500 and engages the pack-off assembly
7 545, and a completion spool 560, gate valve, or other component nipples up to the
8 end of the fluted hanger 540 with a rotatable flange 562 or other connector. In this
9 example, the first hanger 510 can support 7-in. production casing 14, while the
10 second hanger 540 can support 4.5-in. casing 15.

11 In addition to these arrangements of FIGS. 10A-10B, the double-bowl
12 type casing head 500 can be landed through a 20-in. riser using a running tool in
13 much the same manner as depicted in the example of FIG. 8, with the exception
14 that the running tool couples to the outer threaded connection at the top end of the
15 casing head 500. Moreover, the casing head 500 and other components of FIGS.
16 10A-10B can be used with completion spools, adapters, and other conventional
17 components similar to the arrangements in FIGS. 9A-9B (*e.g.*, elements 70, 72, 74,
18 76, 77, 80, and 82).

19 The double-bowl type casing head as shown in FIGS. 10A-10B can be
20 used in various operations when several casing strings are to be run downhole.
21 FIGS. 11A-11D illustrate another wellhead completion assembly 600 in various
22 stages of assembly that can support several casing strings. In addition, to being
23 able to support multiple strings, this assembly 600 has modular head components

1 610 and 620 that offer a number of advantages, including allowing the assembly
2 600 to be assembled in different arrangements and facilitating contingency
3 operations when a stuck pipe occurs before a hanger can be properly landed in the
4 head.

5 As shown in FIG. 11A, the modular assembly 600 includes first and
6 second head components 610 and 620. The first head component 610 can be
7 similar to the casing head of previous embodiments, such as casing head 100 in
8 FIG. 2, and can be used alone in a single bowl type of arrangement. Alternatively,
9 the second head component 620 can connect to the first head component to make
10 a double-bowl type of casing head.

11 In assembling the double bowl arrangement, for example, the first
12 head component 610 connected to outer casing 12 lands on the landing assembly
13 20, and the second head component 620 supported by running tool 54 threads to
14 the first component 610 at a threaded connection 630. This threaded connection
15 630 can use the same type of threading and rating as previous embodiments. For
16 example, this connection 630 can be similar to the connection 106 in FIG. 2 having
17 ACME-2G left-handed thread form and can be 11-in. rated at a working pressure of
18 10,000-PSI. Holes 632 and setscrews (not shown) may also be used to couple the
19 second component 620 to the first component 610. As shown in FIG. 11B, another
20 running tool 54 runs a hanger 650 and attached inner casing 14 through the head
21 components 610/620 and lands the hanger 650 on the shoulder 612 inside the first
22 component 610. Subsequently, as shown in FIG. 11C, another running tool 56
23 lands a pack-off plate 660 above the hanger 650. The modular assembly 600's

1 resulting double-bowl type of arrangement is shown in FIG. 11D. At this point in the
2 assembly, additional pack-off components, another inner casing, and an additional
3 hanger can be landed in the second head component 620 as with the assembly in
4 FIGS. 10A-10B. In this way, the modular assembly 600 can support multiple casing
5 strings. For example, an 11-inch embodiment of the assembly 600 could support
6 two casing strings, while a 13-inch embodiment of the assembly 600 could support
7 three casing strings.

8 As shown in FIGS. 11A-11D, the first and second head components
9 610/620 of the modular assembly 600 can be used to create a double-bowl type of
10 casing head. Because the disclosed assembly 600 is modular, the first head
11 component 610 can be used by itself. As shown in FIGS. 12A-12B, for example,
12 the first head component 610 can be landed on the landing assembly 20 with a
13 running tool 54, and a quick connect drilling adapter 530 or some other desired
14 component can be attached to the first component 610 to complete the assembly.
15 Alternatively, the first head component 610 can be used in other arrangements
16 disclosed herein, such as in FIGS. 2, 3A, 4, and 9A-9B. In another alternative
17 shown in FIG. 13, two of the second head components 620a-b can be stacked on
18 top of one another above the first head component 610 to create a three component
19 modular assembly, which can be used to support multiple casing strings.

20 Not only does the modular assembly 600 provide for versatile
21 arrangements, but it facilitates contingency operations when a stuck pipe occurs.
22 When running the casing 14 and hanger 650 through the head components 610/620
23 and the outer casing 12, for example, the inner casing 14 may become stuck in

1 what is commonly referred to as a stuck pipe situation—an example of which is
2 shown in FIG. 14A. Because the inner casing 14 cannot be inserted enough to
3 allow the attached hanger 650 to be landed on the shoulder 612, operators must
4 perform a contingency operation that involves using slips to secure the inner casing
5 14 in tension within the casing head and cutting the excess portion from the inner
6 casing 14 that has been prevented from passing through the casing head.

7 In a conventional double-bowl casing head, cutting the excess casing
8 can be difficult because the point at which the cut must be made lies deep within the
9 double-bowl casing head. In other words, an operator has to carefully cut the
10 casing within the confined space of the double-bowl head with a welding tool and
11 then to prepare the end of the cut casing properly for further operations.

12 The modular assembly 600, however, facilitates stuck pipe
13 contingency operations. When a stuck pipe occurs as in FIG. 14A, operators
14 position a slip assembly 670 and pack-off 672 in the first component 610 as shown
15 in FIG. 14B and then remove the second component 620 from the first component
16 610 at the threaded connection 630. Removing the second component 620 leaves
17 the excess casing 14 exposed above the first component 610. Operators can then
18 more readily cut the excess casing 14 at the appropriate point, level the cut end 15,
19 and create the needed chamfer at the edge. After these steps have been
20 completed, operators can reconnect the second component 620 to the first
21 component 610. Alternatively, operators can attach a rotating flange 674 to the
22 connection end 631 of the first component 610 as shown in FIG. 14C or couple
23 components of some other desired arrangement to the first component 610.

1 In addition to facilitating preparation of the inner casing 14 during
2 stuck pipe contingency operations, the modular assembly 600 also helps operators
3 perform modifications to a control line when a stuck pipe occurs. For example, FIG.
4 15A shows the modular assembly 600 having a control line 700 that runs down the
5 annulus to a valve or the like (not shown). The control line 700 connects by a
6 ferrule coupling 702 to a hanger 650, and a side coupling 704 in the first head
7 component 610 communicates with a port in the hanger 650 to communicate with
8 the control line 700.

9 If a stuck pipe occurs while running the inner casing 14, the hanger
10 650, and the control line 700 downhole, operators have to modify the arrangement
11 of the control line 700 to connect it to the side coupling 704. In a conventional
12 double-bowl type of head, operators would have to modify the control line's
13 connection by making modifications deep within the double-bowl head and confined
14 in the annulus between the inner casing and the head.

15 The disclosed modular assembly 600, however, alleviates some of
16 this difficulty. For example, as shown in FIGS. 15B, the second component 620 can
17 be removed from the first head component 610 giving operators easier access to
18 the control line 700 and the inside of the coupling 704. Before putting the slip
19 assembly 670 and pack-off 672 in the head, for example, operators can wind
20 excess amounts of control line 700 in wraps 705 around the casing 14 and attach
21 the line 700 to the coupling 704 inside the first component 610 while having easier
22 access inside the annulus. After setting up the control line 700, putting the slip
23 assembly 670 and pack-off 672 in the first head component 610, and cutting the

1 excess of the casing 14, operators can reconnect the second component 620 to the
2 first component 610. Alternatively, operators can attach a rotating flange 674 to the
3 end of the first component 610 as shown in FIG. 15C, or couple components of
4 some other desired arrangement to the first component 610.

5 The foregoing description of preferred and other embodiments is not
6 intended to limit or restrict the scope or applicability of the inventive concepts
7 conceived of by the Applicants. For example, it will be appreciated with the benefit
8 of the present disclosure that components of one embodiment of the wellhead
9 completion assembly can be combined with components of another embodiment to
10 produce a variety of versatile arrangements for well completions. In exchange for
11 disclosing the inventive concepts contained herein, the Applicants desire all patent
12 rights afforded by the appended claims. Therefore, it is intended that the appended
13 claims include all modifications and alterations to the full extent that they come
14 within the scope of the following claims or the equivalents thereof.

15

1 WHAT IS CLAIMED IS:

2

3 1. A wellhead completion assembly, comprising:

4 a casing head connecting to casing at a wellhead and having a first external
5 threaded connection adjacent a first end;

6 a casing hanger landing in the casing head and having a second end, the second
7 end extending beyond the first end of the casing head and having a second
8 external threaded connection, the second external threaded connection
9 connectable to a connector to support at least one additional component
10 above the casing hanger; and

11 a locking ring threadably connecting to the first external threaded connection of the
12 casing head and defining an opening through which the second end of the
13 casing hanger extends,

14 wherein a portion of the locking ring directly engages a shoulder on the casing
15 hanger, and

16 wherein the casing hanger comprises

17 a pair of sealing seats on an outer surface, and

18 a test port defined in the shoulder and accessible through the opening in the
19 locking ring, the test port communicating between the pair of sealing
20 seats.

21

1

2 2. A wellhead completion assembly, comprising:

3 a casing head connecting to casing at a wellhead and having a first external
4 threaded connection adjacent a first end;5 a casing hanger landing in the casing head and having a second end, the second
6 end extending beyond the first end of the casing head and having a second
7 external threaded connection, the second external threaded connection
8 connectable to a connector to support at least one additional component
9 above the casing hanger;10 a locking ring threadably connecting to the first external threaded connection of the
11 casing head and defining an opening through which the second end of the
12 casing hanger extends; and13 a pack-off plate disposed in the casing head between the casing hanger and a
14 portion of the locking ring.

15

16 3. The assembly of claim 2, wherein the pack-off plate comprises:

17 an upper surface positioning adjacent the portion of the locking ring;

18 an inner portion engaging an external surface of the casing hanger, and

19 an outer portion engaging an internal surface of the casing head.

20

21 4. The assembly of claim 3, wherein the pack-off plate comprises:

22 a first pair of sealing seats on the outer portion,

23 a second pair of sealing seats on the inner portion, and

24 a test port defined in the upper surface and accessible through the opening in the
25 locking ring, the test port communicating with the inner and outer portions
26 between the first and second pairs of sealing seats.

1

2 5. The assembly of any one of claims 1 to 4, wherein the casing head comprises a
3 single-bowl arrangement defining an internal shoulder within an internal bore, the casing
4 hanger landing on the internal shoulder to be supported therein.

5

6 6. The assembly of any one of claims 1 to 4, wherein the casing head comprises a
7 double-bowl arrangement defining an internal shoulder within an internal bore, the casing
8 hanger landing on one or more components supported by the internal shoulder.

9

10 7. The assembly of claim 6, wherein the casing head for the double-bowl arrangement
11 comprises and least two head components interconnectable to one another, a first of the
12 head components having the internal shoulder therein, a second of the head components
13 having the first external threaded connection to which the locking ring threadably connects.

14

15 8. A wellhead completion assembly, comprising:

16 a casing head connecting to a first casing and having a first external threaded
17 connection adjacent a first end;

18 a casing hanger landing in the casing head and having a shoulder and a second
19 end, the second end extending beyond the first end of the casing head and
20 having a second external threaded connection, the second external threaded
21 connection connectable to a connector to support at least one additional
22 component above the casing hanger;

23 a locking ring threadably connecting to the first external threaded connection of the
24 casing head and defining an opening through which the second end of the
25 casing hanger extends; and

1 at least one pack-off component positioning between the shoulder of the casing
2 hanger and a portion of the locking ring, the at least one pack-off component
3 sealably engaging an external surface of the casing hanger and sealably
4 engaging an internal surface of the casing head.

5

6 9. The assembly of claim 8, wherein the casing head comprises a single-bowl
7 arrangement defining an internal shoulder within an internal bore, the casing hanger
8 landing on the internal shoulder to be supported therein.

9

10 10. The assembly of claim 8, wherein the casing head comprises a double-bowl
11 arrangement defining an internal shoulder within an internal bore, the casing hanger
12 landing on one or more other components supported by the internal shoulder.

13

14 11. The assembly of claim 10, wherein the casing head for the double-bowl
15 arrangement comprises at least two head components interconnectable to one another, a
16 first of the head components having the internal shoulder therein, a second of the head
17 components having the first external threaded connection to which the locking ring
18 threadably connects.

19

20 12. The assembly of claim 10, wherein the casing hanger defines at least one flute, and
21 wherein the at least one pack-off component seals fluid communication through the at least
22 one flute.

23

24 13. The assembly of claim 10, wherein the at least one pack-off component comprises a
25 pack-off plate having

1 an inner portion threadably connecting to a third threaded connection on the
2 external surface of the casing hanger, and
3 an outer portion sealably engaging the internal surface of the casing head.

4
5 14. The assembly of claim 13, wherein the at least one pack-off component comprises a
6 sealing ring positionable about the external surface of the casing hanger, and wherein the
7 pack-off plate comprise a lip positionable in wedged engagement between the sealing ring
8 and a portion of the external surface of the casing hanger.

9
10 15. The assembly of claim 10, wherein the at least one pack-off component comprises a
11 pack-off plate having

12 a first pair of sealing seats on an outer portion,
13 a second pair of seals on an inner portion, and
14 a test port defined in an upper surface of the plate and accessible through the
15 opening in the locking ring, the test port communicating with the outer
16 portion between the first pair of sealing seats and communicating with the
17 inner portion between the second pair of sealing seats.

18
19 16. A wellhead completion assembly, comprising:
20 a first head component having a first internal threaded connection adjacent one end
21 connectable to casing at a wellhead and having a first external threaded
22 connection adjacent another end, the first head component defining a
23 shoulder therein; and
24 one or more second head components having second internal threaded connections
25 adjacent one end and having second external threaded connections
26 adjacent another end, the second internal threaded connection connectable

1 to the first external threaded connection on the first head component, the
2 second internal and external threaded connections of the second head
3 components interconnectable to one another;
4 a casing hanger landable on the shoulder in the first head component and having a
5 distal end extending beyond the end of the first head component, the distal
6 end having an external threaded connection connectable to a connector to
7 support at least one additional component above the casing hanger; and
8 a locking ring threadably connectable to the first external threaded connection on
9 the first head component in the single-bowl arrangement and defining an
10 opening through which the distal end of the casing hanger extends,
11 wherein the first head component is used independently on the wellhead for a
12 single-bowl arrangement of the wellhead completion assembly, and
13 wherein the one or more second head components are used in conjunction with the
14 first head component for a multiple-bowl arrangement of the wellhead
15 completion assembly.

16
17 17. The assembly of claim 16, wherein a portion of the locking ring directly engages a
18 shoulder of the casing hanger, and wherein the casing hanger comprises:
19 a pair of sealing seats on an outer surface, and
20 a test port defined in the shoulder and accessible through the opening in the locking
21 ring, the test port communicating between the pair of sealing seats.

22
23 18. The assembly of claim 16, further comprising a pack-off plate disposed in the first
24 head component between the casing hanger and a portion of the locking ring, wherein the
25 pack-off plate comprises:
26 an upper surface positioning adjacent the portion of the locking ring;

1 an inner portion engaging an external surface of the casing hanger, and
2 an outer portion engaging an internal surface of the first head component.

3

4 19. The assembly of claim 18, wherein the pack-off plate comprises:

5 a first pair of sealing seats on the outer portion,

6 a second pair of sealing seats on the inner portion, and

7 a test port defined in the upper surface and accessible through the opening in the
8 locking ring, the test port communicating with the inner and outer portions
9 between the first and second pairs of sealing seats.

10

11 20. A hanger pack-off assembly, comprising:

12 a casing hanger positionable in a casing head and having a first external threaded
13 connection about an external surface; and

14 a pack-off plate defining an opening through first and second sides of the plate, the
15 opening having a first internal threaded connection threading onto the first external
16 threaded connection on the casing hanger, an outer surface of the plate having a first pair
17 of sealing seats formed thereabout, an inner surface of the plate having a second pair of
18 sealing seats formed thereabout, a test port defined in the first side of the plate and
19 communicating with the inner and outer surfaces between the first and second pairs of
20 sealing seats.

21

22 21. The assembly of claim 20, further comprising a sealing ring positionable about the
23 external surface of the casing hanger, and wherein the pack-off plate comprise a lip
24 positionable in wedged engagement between the sealing ring and a portion of the external
25 surface of the casing hanger.

26

1 22. The assembly of claim 20, further comprising a locking ring threadably connecting to
2 the casing head and defining an opening therethrough, wherein the casing hanger has a
3 distal end extending through the opening, the distal end having a second external threaded
4 connection to which a component connects to the casing hanger.

5

6 23. A wellhead completion method, comprising:

7 connecting a casing head to surface casing;

8 landing a casing hanger in the casing head to support production casing in the
9 surface casing such that an upper end of the casing hanger extends beyond
10 an upper end of the casing head;

11 disposing a pack-off plate on the upper end of the casing hanger, the pack-off plate
12 sealably engaging an external surface of the casing hanger and sealably
13 engaging an internal surface of the casing head;

14 threadably connecting a locking ring on the upper end of the casing head and
15 directly engaging an upper surface of the pack-off plate with the locking ring,
16 the upper end of the casing head fitting through an opening of the locking
17 ring;

18 threading a connector to the upper end of the casing hanger; and

19 connecting an additional component above the casing hanger by connecting to the
20 connector.

21

22 24. The method of claim 23, wherein disposing the pack-off plate on the upper end of
23 the casing hanger comprises threading an inside portion of the pack-off plate on external
24 thread on the upper end of the casing hanger.

25

1 25. The method of claim 23, wherein disposing the pack-off plate on the upper end of
2 the casing hanger comprises sealing an inner pair of seals on the pack-off plate against the
3 external surface of the casing hanger and sealing an outer pair of seals on the pack-off
4 plate against the internal surface of the casing head.

5

6 26. The method of claim 25, further comprising testing the inner and outer pairs of seals
7 via a test port defined in the upper surface of the pack-off plate and accessible through the
8 opening in the locking ring.

9

10 27. The method of claim 23, wherein disposing the pack-off plate on the upper end of
11 the casing hanger comprises:

12 wedging a lip on the pack-off plate between a hanger ring and the external surface
13 of the casing hanger, and
14 engaging the hanger ring against the internal surface of the casing head.

15

16 28. The method of claim 23, wherein threading the connector to the upper end of the
17 casing hanger comprises threading a rotatable flange to the upper end of the casing
18 hanger.

19

20 29. The method of claim 28, wherein connecting the additional component above the
21 casing hanger comprises connecting a gate valve for a fracing operation to the rotatable
22 flange.

23

24 30. The method of claim 23, wherein before threadably connecting the locking ring,
25 threading the connector to the upper end of the casing hanger, and connecting the
26 additional component above the casing hanger, the method comprises initially removing a

1 blow out preventer stack and a first rotatable flange from the casing head, the first rotatable
2 flange being threaded on an external thread on the casing head.

3

4 31. The method of claim 30, wherein the first rotatable flange is rated for a first working
5 pressure, and wherein the connector threading to the upper end of the casing hanger
6 comprises a second rotatable flange having a second working pressure greater than the
7 first working pressure.

8

9 32. The method of claim 23, wherein landing the casing hanger comprises passing the
10 casing hanger on a running tool through a blow out preventer stack installed on the casing
11 head.

12

13 33. A wellhead completion assembly, comprising:
14 a first head component having one end connectable to casing at a wellhead and
15 having a first external threaded connection adjacent another end; and
16 second head components each having second internal threaded connections
17 adjacent one end and having second external threaded connections
18 adjacent another end, the second internal threaded connection connectable
19 to the first external threaded connection on the first head component, the
20 second internal and second external threaded connections of the second
21 head components being complementary and threadably interconnectable to
22 one another,
23 wherein the first head component is used independently on the wellhead for a
24 single-bowl arrangement of the wellhead completion assembly,
25 wherein one of the second head components is used in conjunction with the first
26 head component for a first multiple-bowl arrangement of the wellhead

1 completion assembly, the second internal threaded connection of the one
2 second head component connecting to the first external threaded connection
3 on the first head component to stack the one second head component on top
4 of the first head component; or

5 wherein two or more of the second head components are used in conjunction with
6 the first head component for second multiple-bowl arrangements of the
7 wellhead completion assembly, the second internal and second external
8 threaded connections of the second head components interconnecting to
9 one another to stack the two or more second head components on top of
10 one another, the internal threaded connection of a lowermost one of the
11 second head components connecting to the first external threaded
12 connection on the first head component to stack the second head
13 components on top of the first head component.

14

15 34. The assembly of claim 33, further comprising:

16 a casing hanger supported in the wellhead completion assembly, the casing hanger
17 having a distal end extending beyond a topmost end of the wellhead
18 completion assembly, the distal end having an external threaded connection
19 connectable to a connector to support at least one additional component
20 above the casing hanger; and

21 a locking ring threadably connectable to the first external threaded connection on
22 the first head component in the single-bowl arrangement or threadably
23 connectable to the second external connection of a topmost one of the
24 second head components in the multi-bowl arrangement, the locking ring
25 defining an opening through which the distal end of the casing hanger
26 extends.

1

2 35. The assembly of claim 34, wherein a portion of the locking ring directly engages a
3 shoulder of the casing hanger, and wherein the casing hanger comprises:

4 a pair of sealing seats on an outer surface, and

5 a test port defined in the shoulder and accessible through the opening in the locking
6 ring, the test port communicating between the pair of sealing seats.

7

8 36. The assembly of claim 34, further comprising a pack-off plate disposed in the
9 topmost end of the wellhead completion assembly between the casing hanger and a portion
10 of the locking ring, wherein the pack-off plate comprises:

11 an upper surface positioning adjacent the portion of the locking ring;

12 an inner portion engaging an external surface of the casing hanger, and

13 an outer portion engaging an internal surface of the wellhead completion assembly.

14

15 37. The assembly of claim 36, wherein the pack-off plate comprises:

16 a first pair of sealing seats on the outer portion,

17 a second pair of sealing seats on the inner portion, and

18 a test port defined in the upper surface and accessible through the opening in the
19 locking ring, the test port communicating with the inner and outer portions
20 between the first and second pairs of sealing seats.

21

22

⊕

1/9

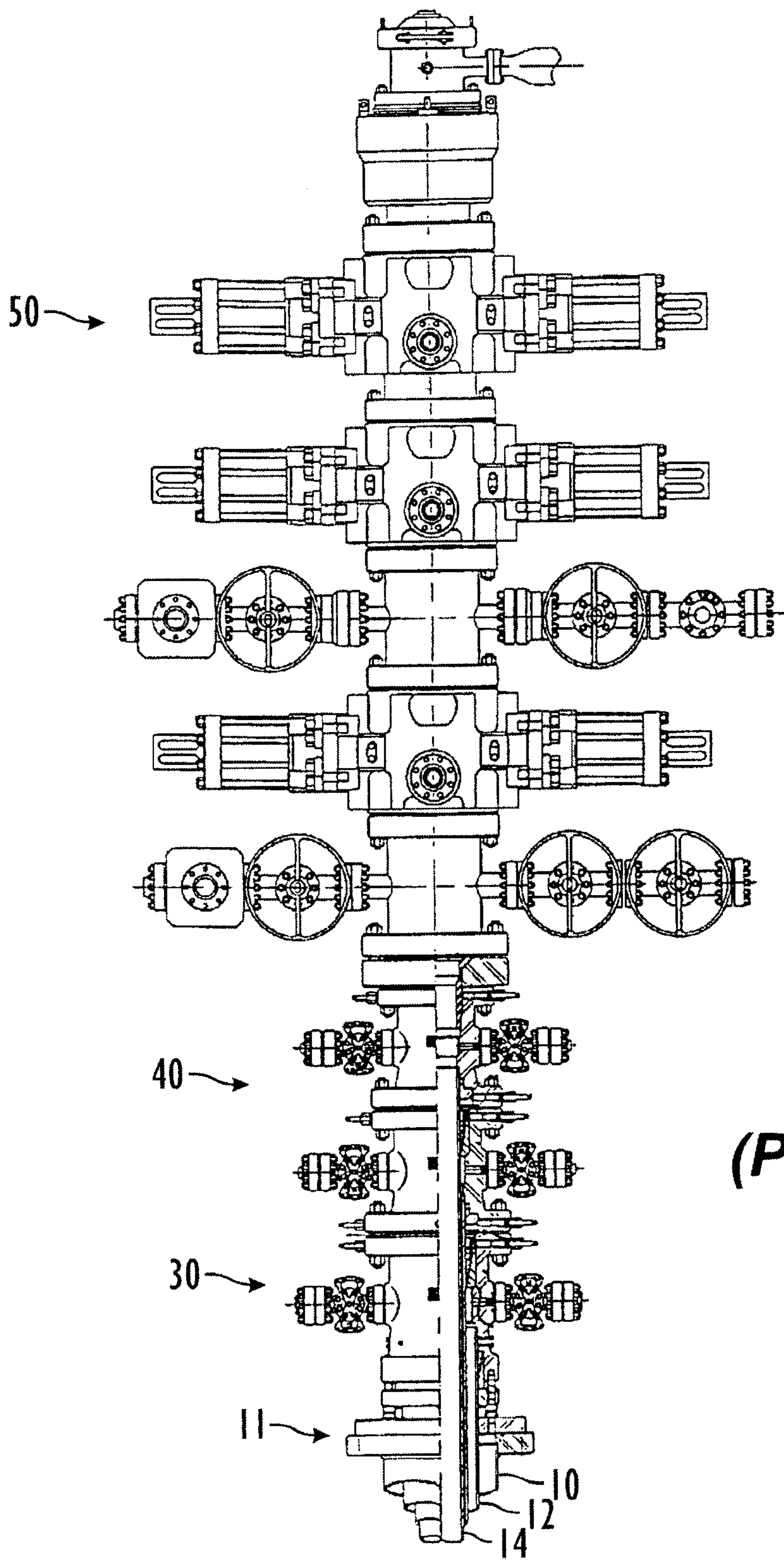

FIG. 1
(Prior Art)

⊕

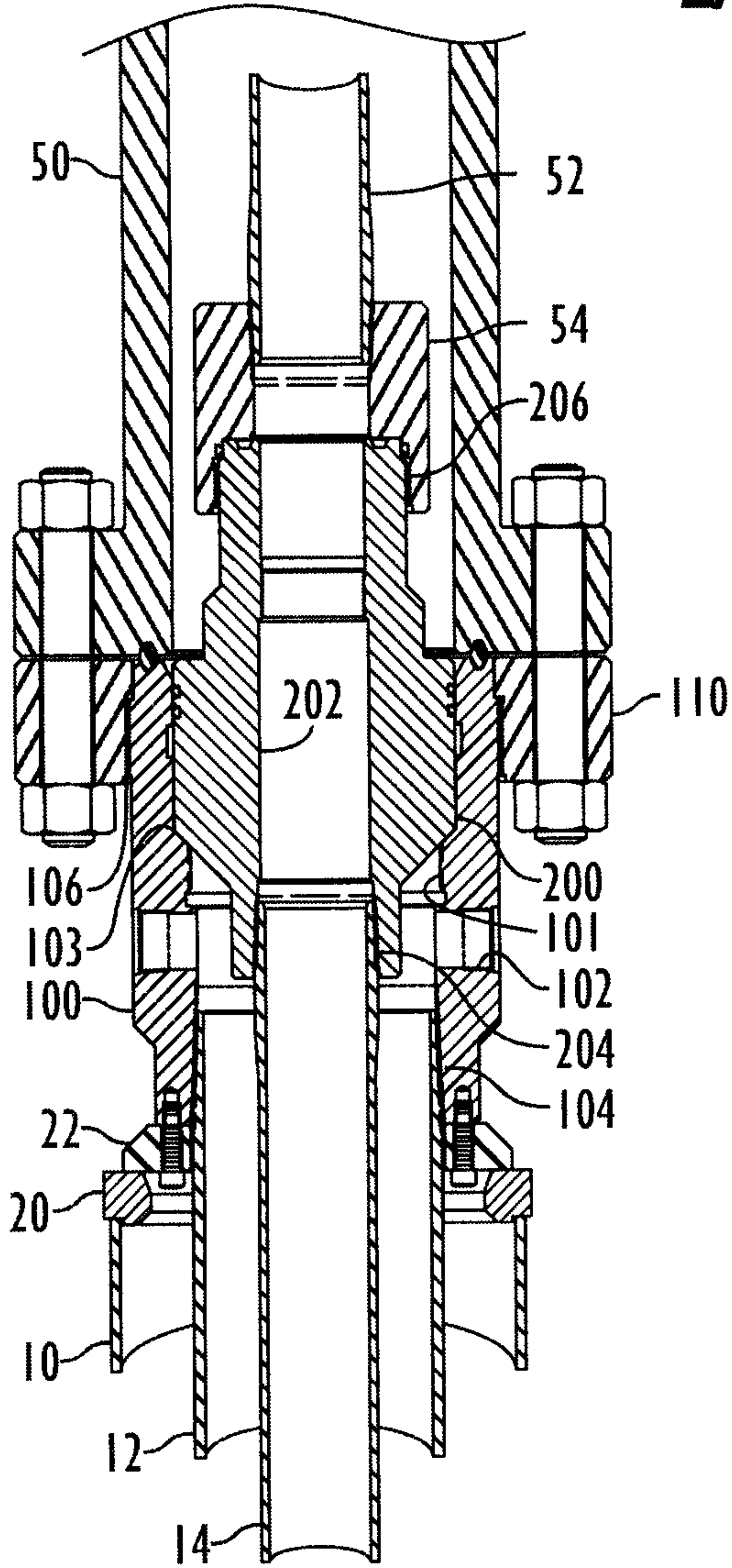

FIG. 2

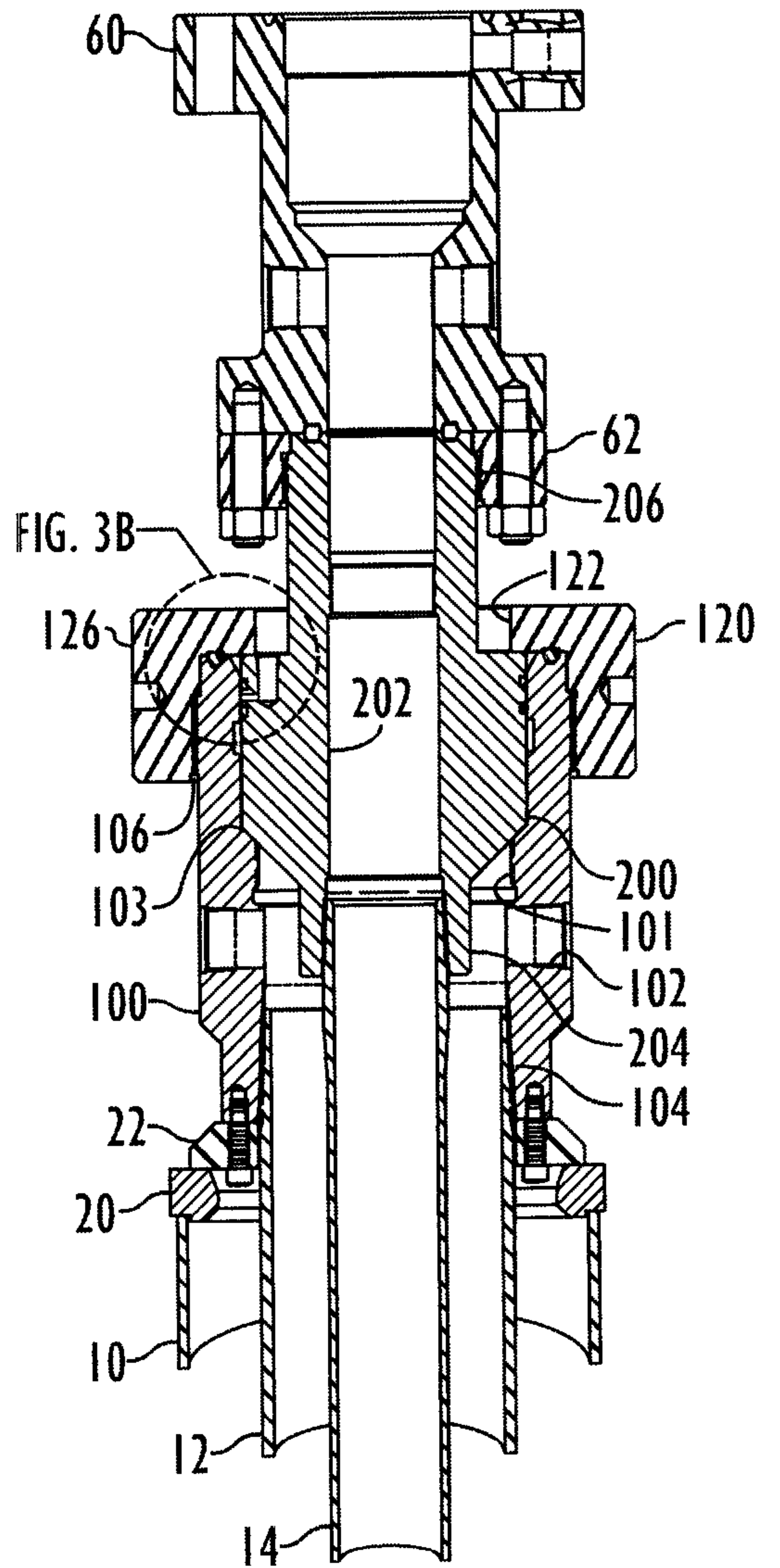

FIG. 3A

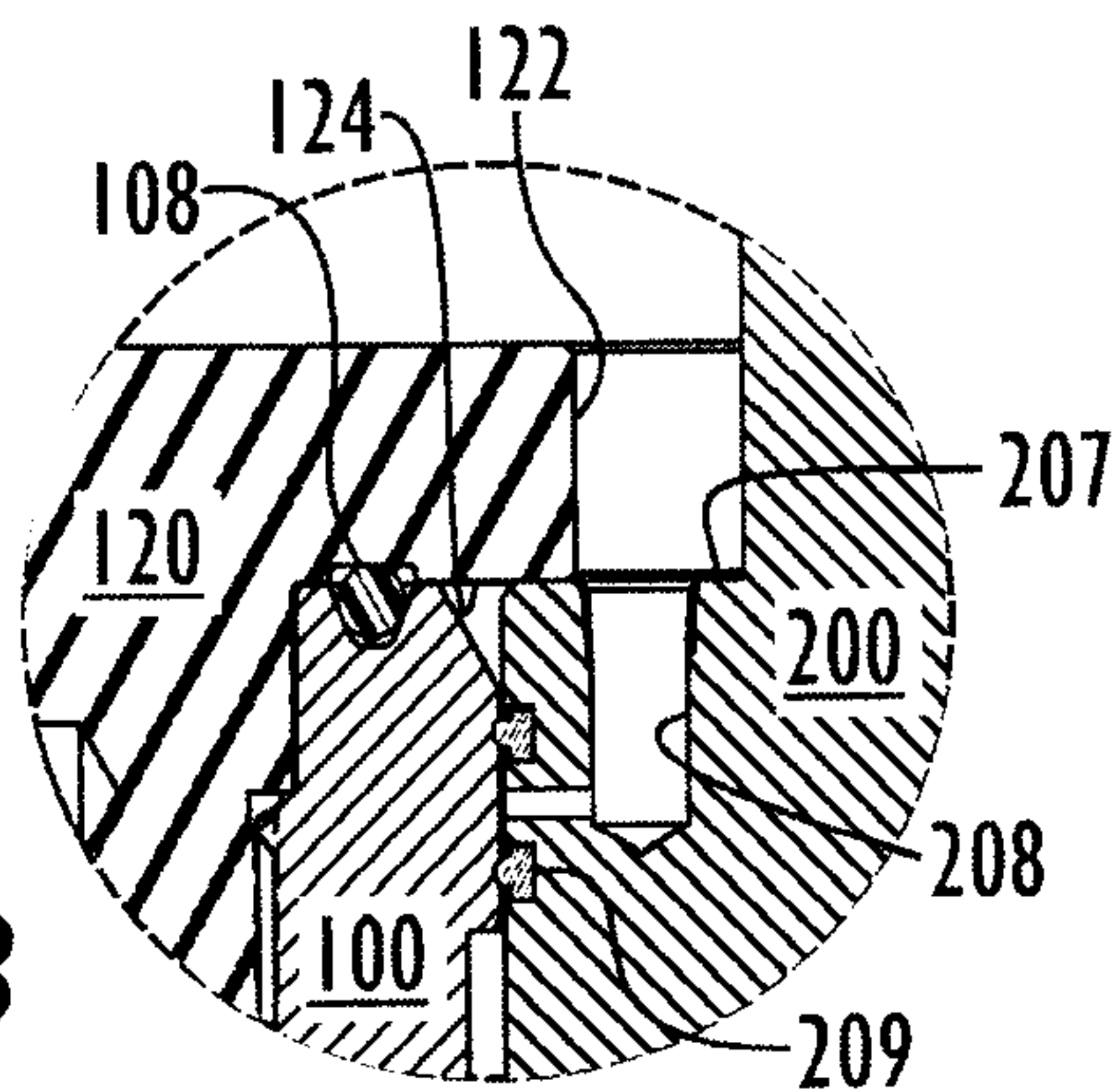

FIG. 3B

⊕

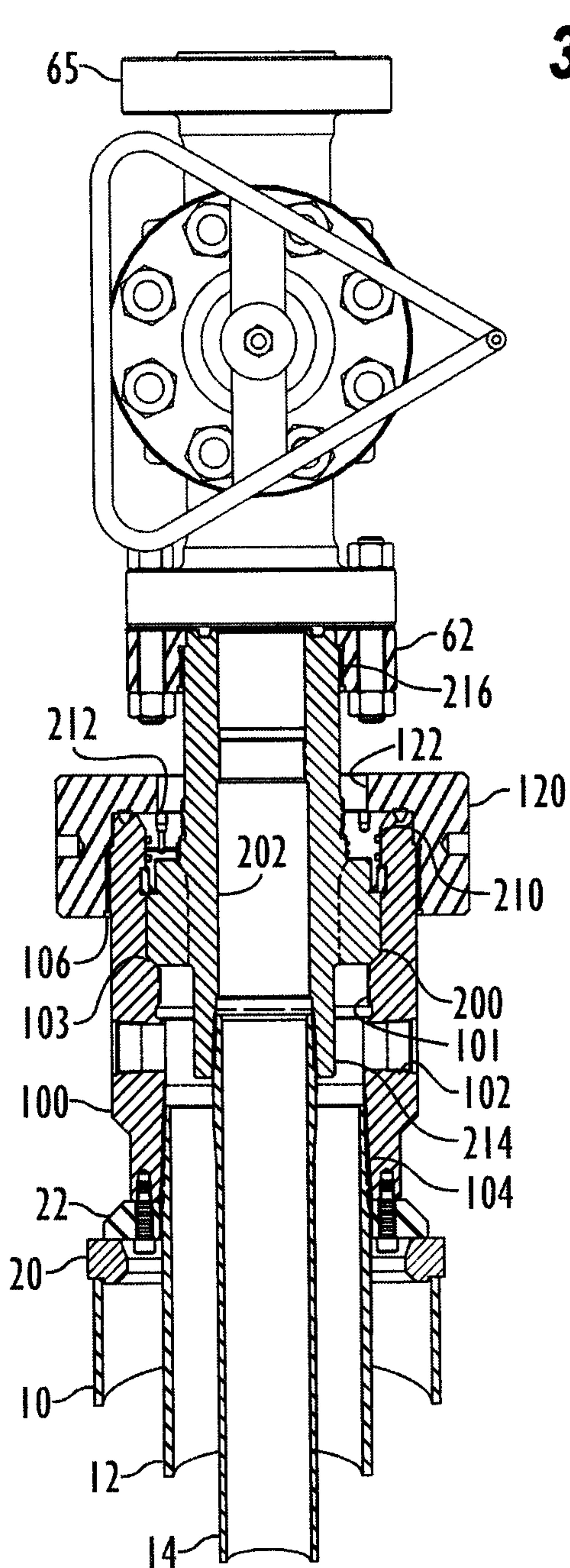

FIG. 4

3/9

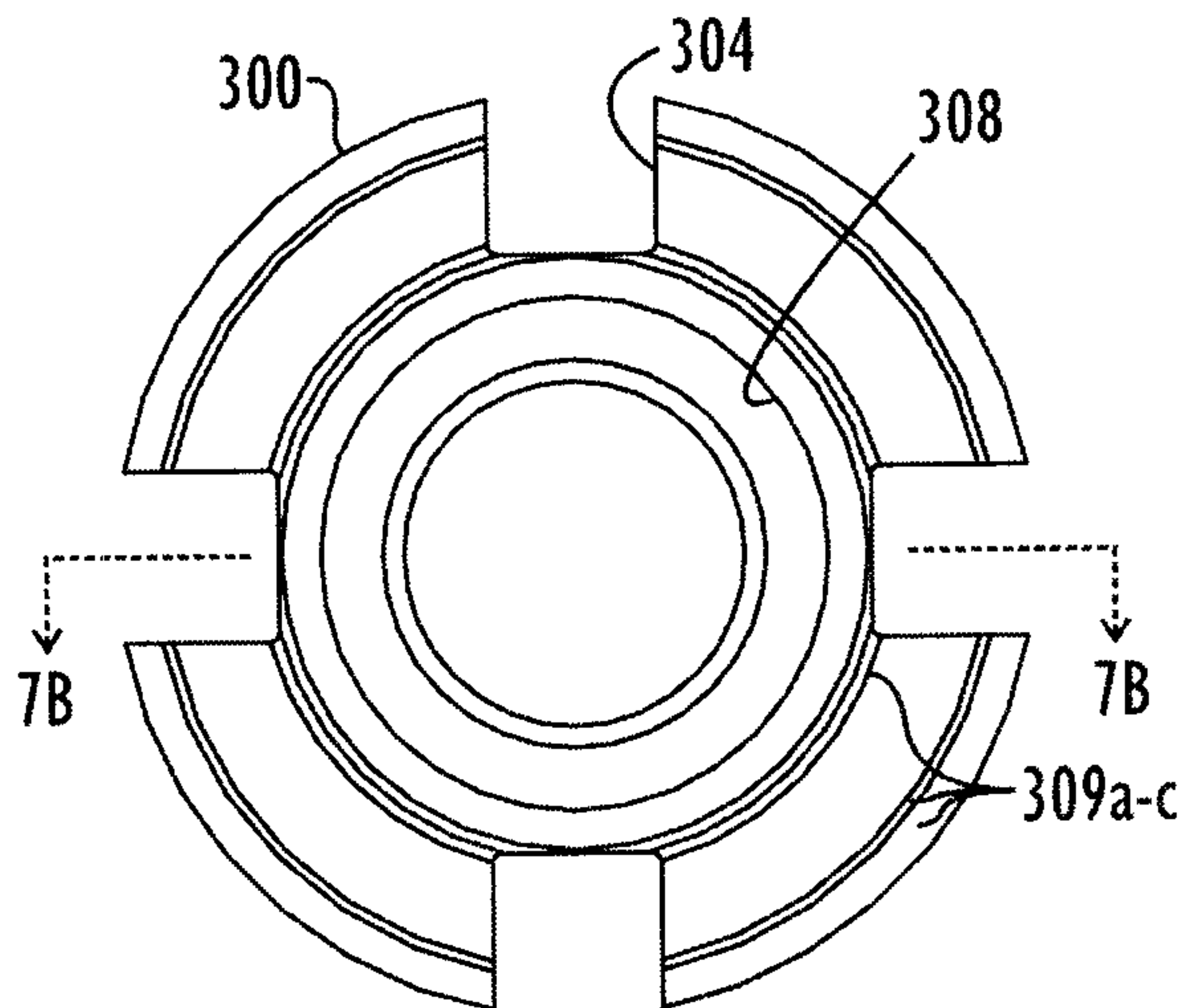

FIG. 5A

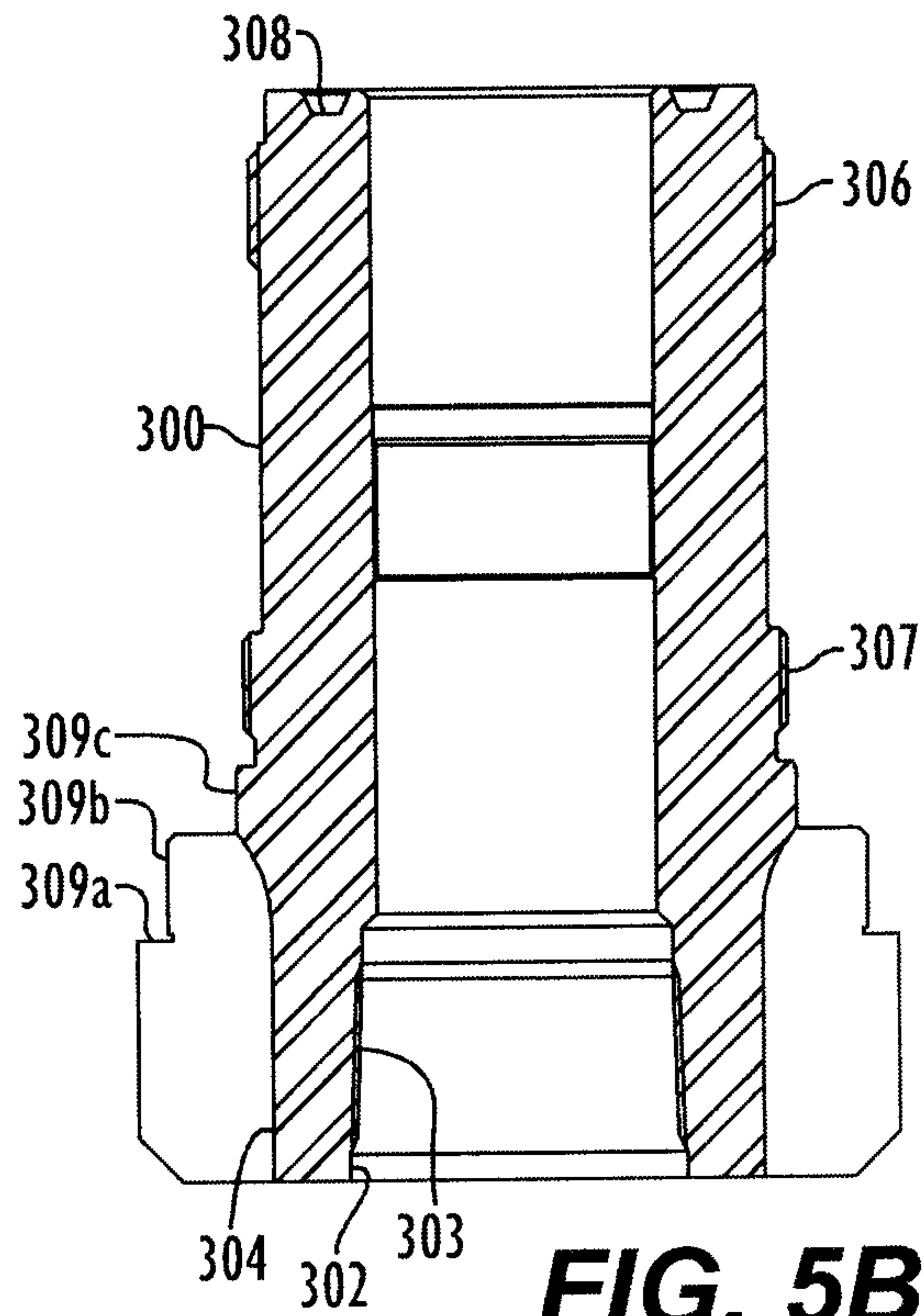

FIG. 5B

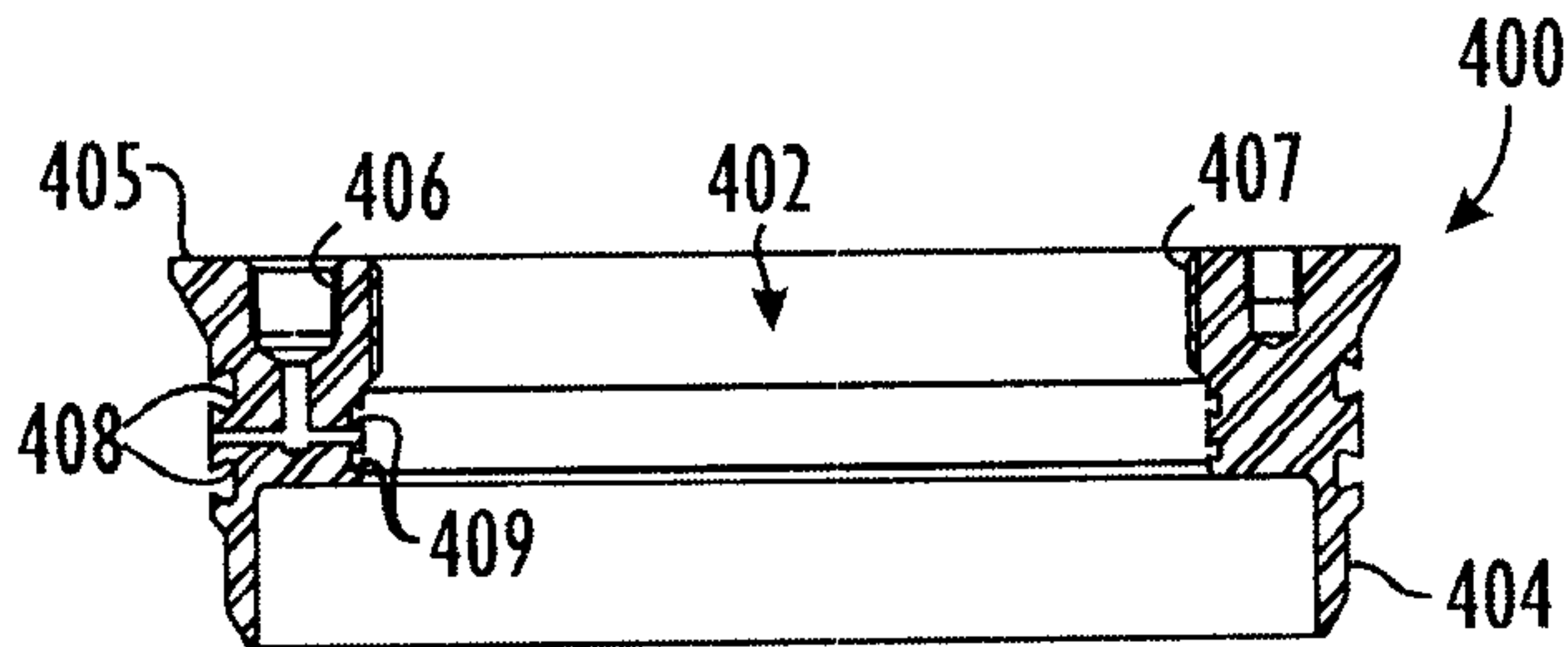

FIG. 6

⊕

4/9

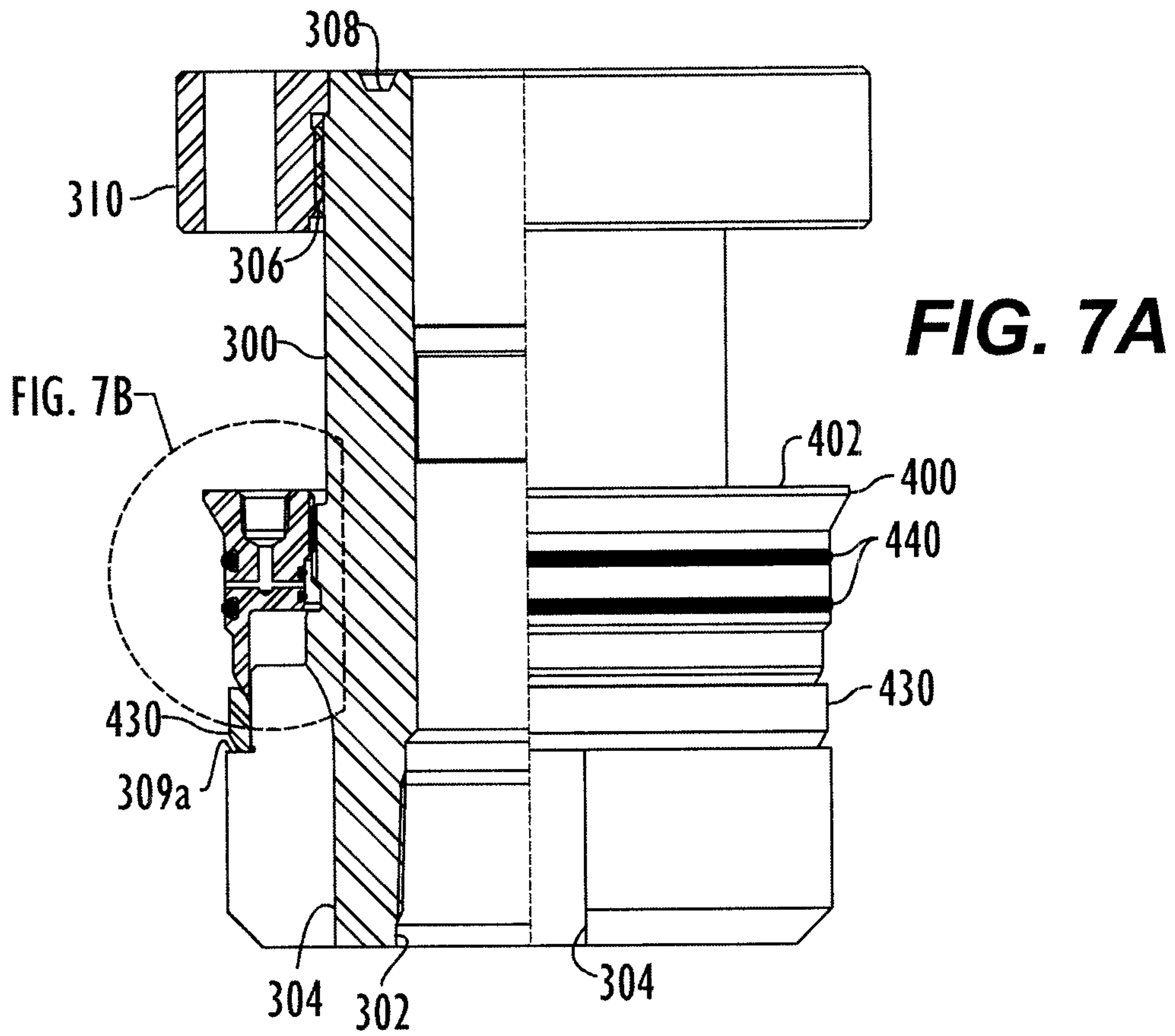

FIG. 7B

FIG. 7A

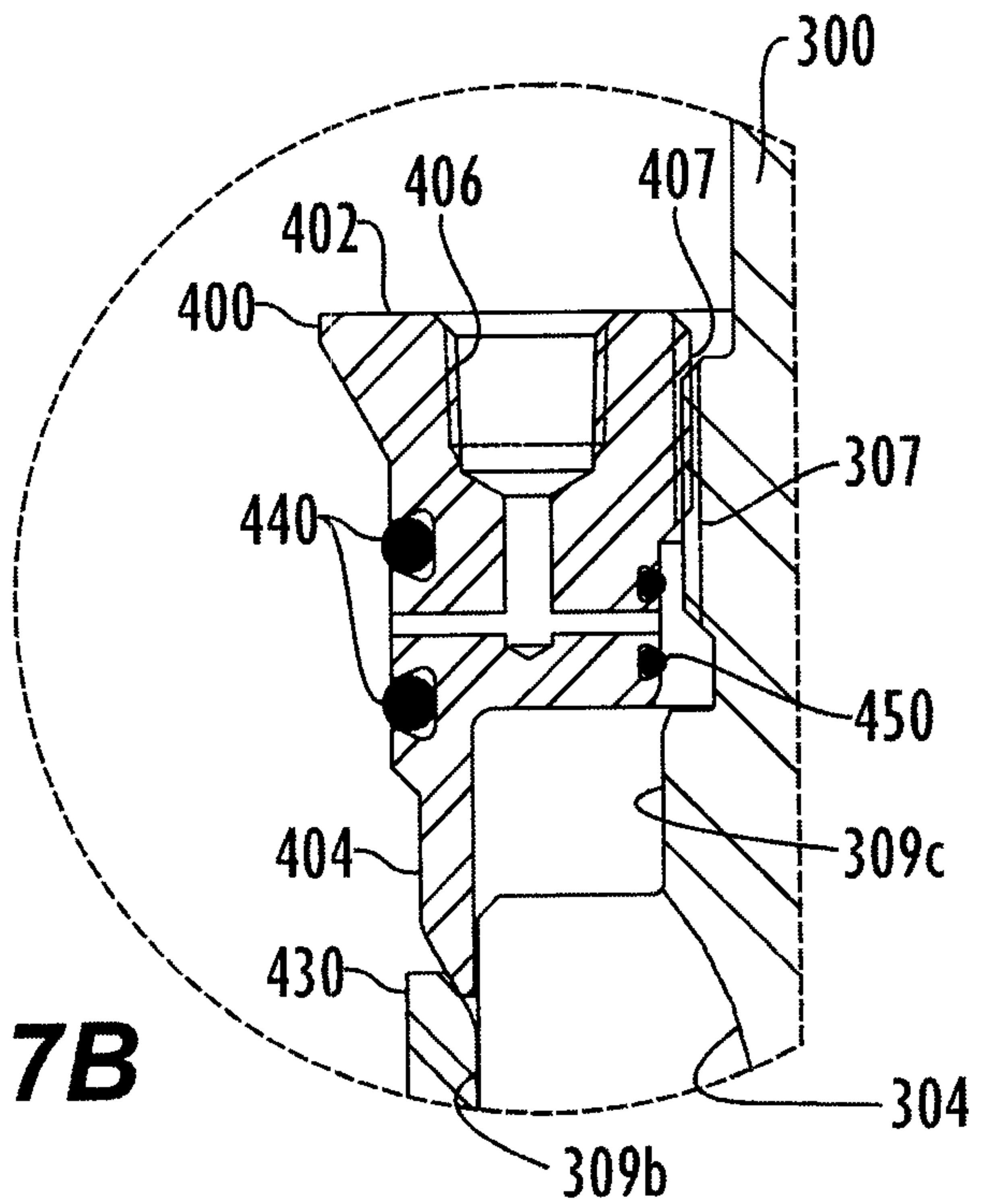

FIG. 7B

Φ

5/9

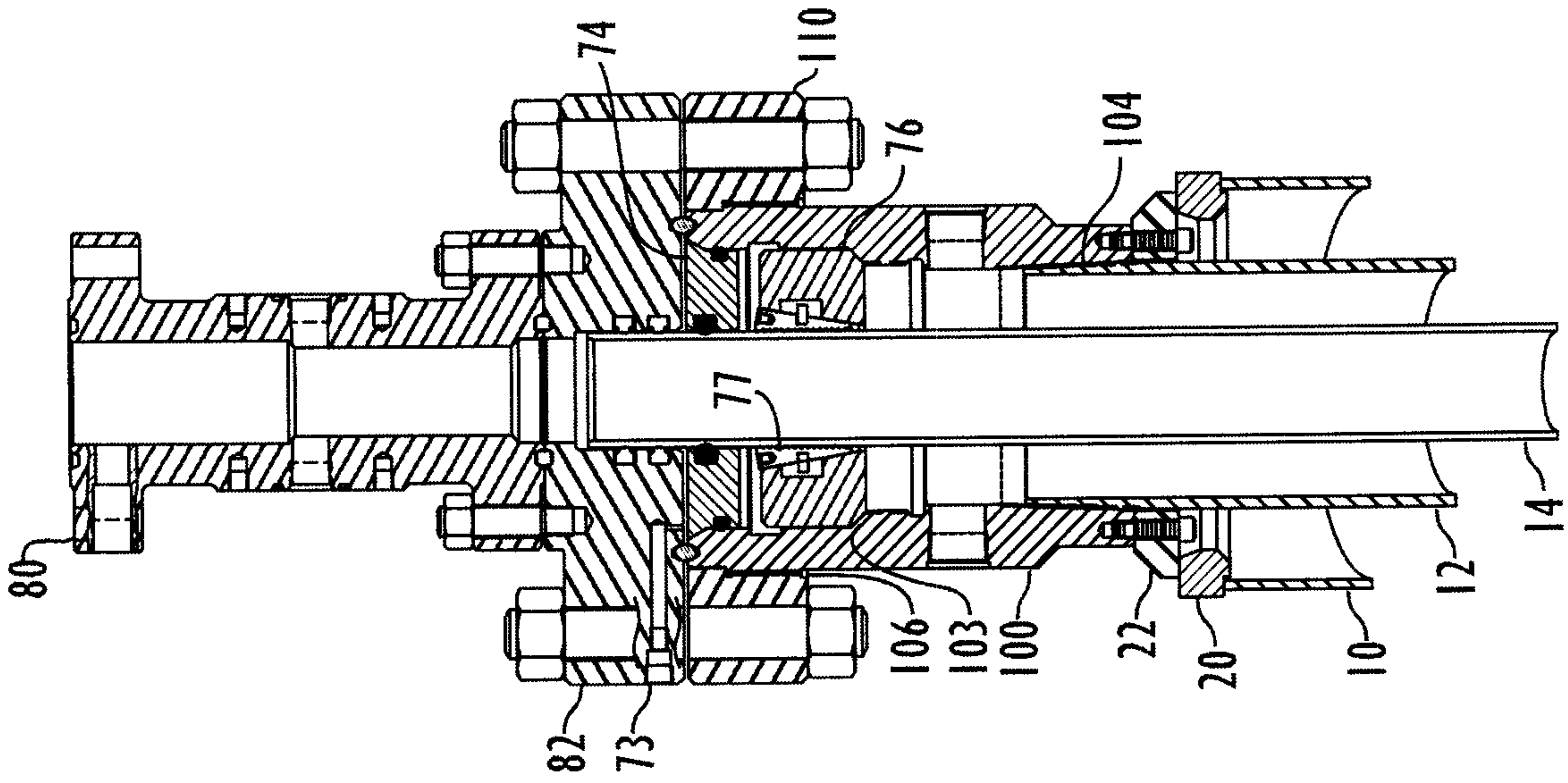

FIG. 9B

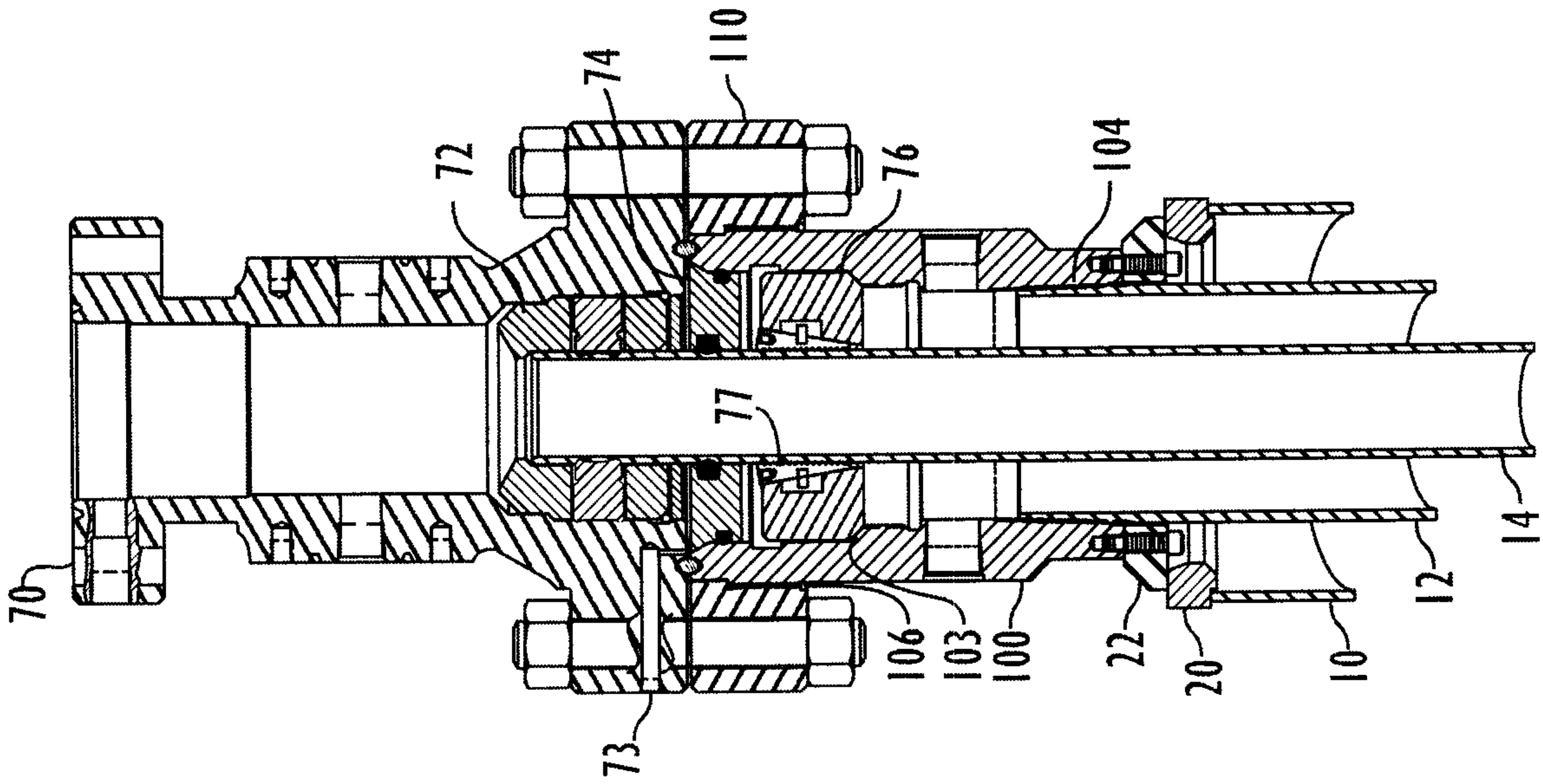

FIG. 9A

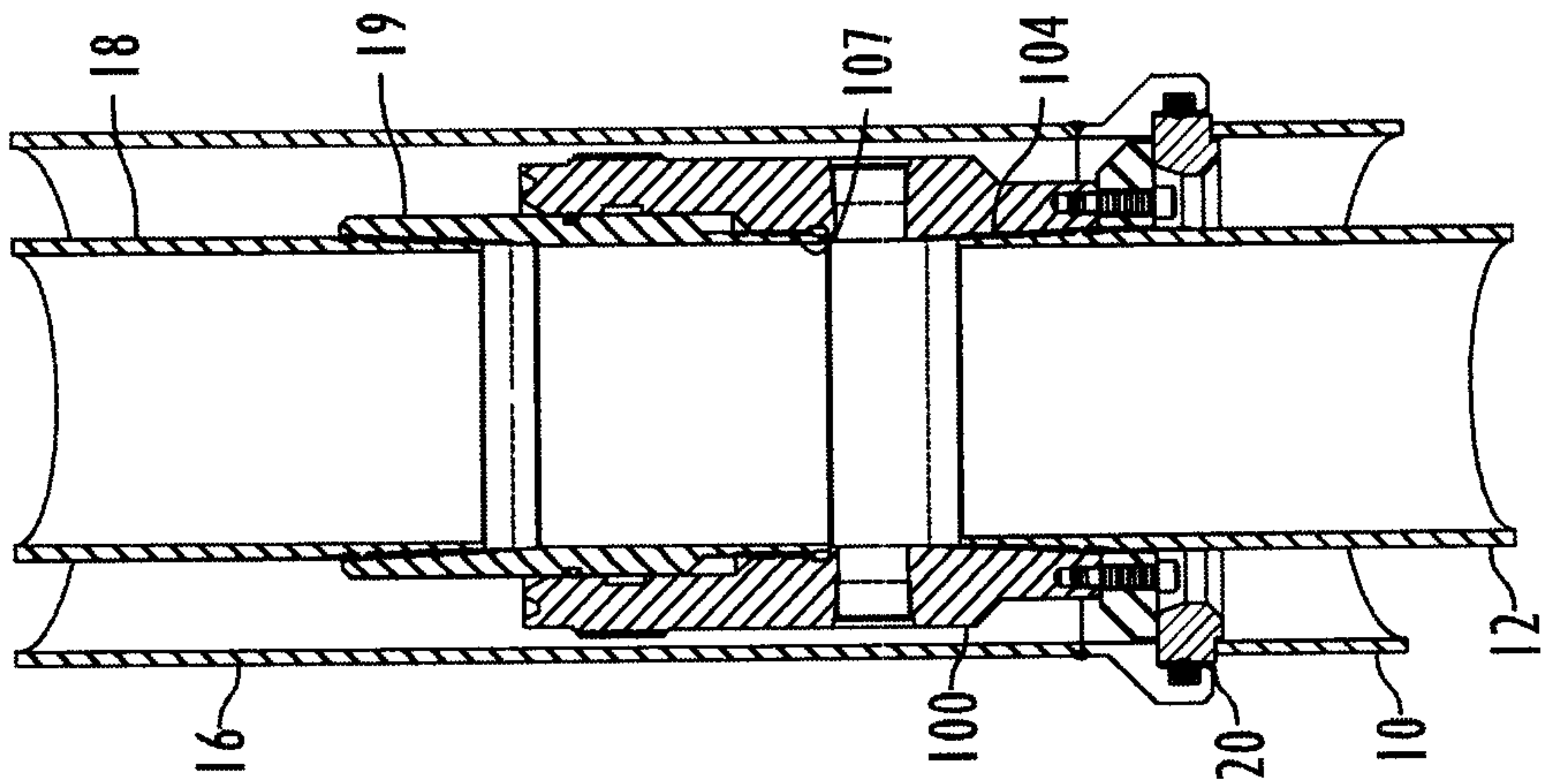

FIG. 8

Φ

⊕

6/9

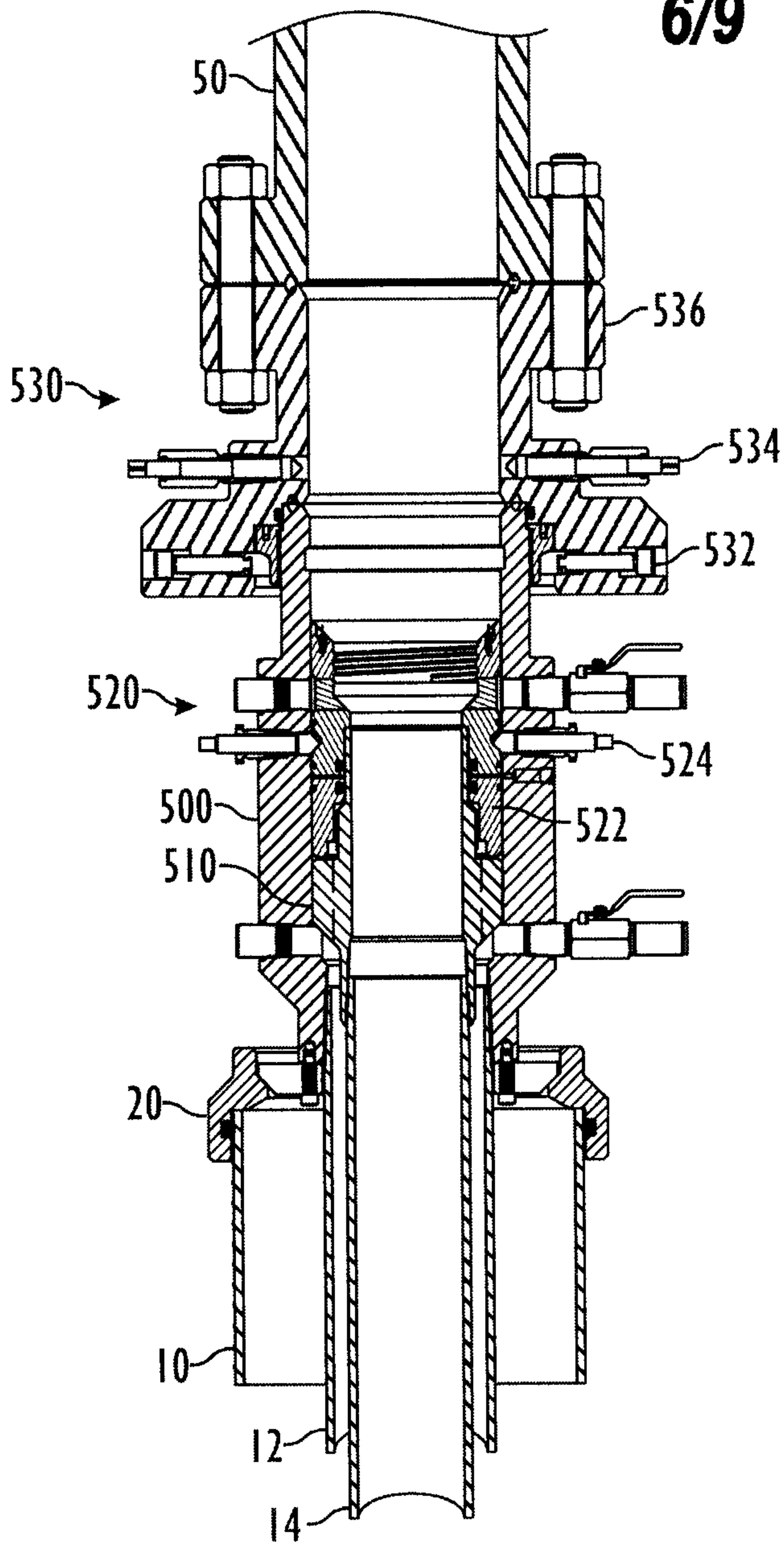

FIG. 10A

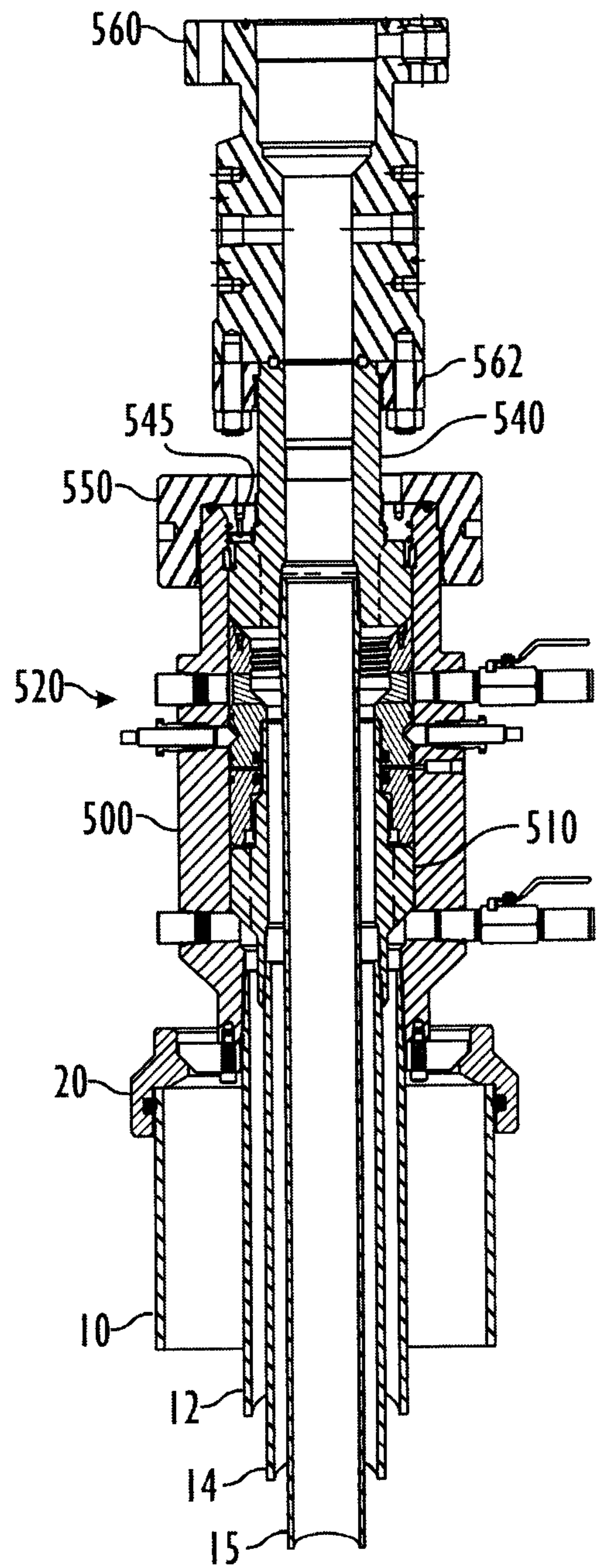

FIG. 10B

⊕

⊕

7/9

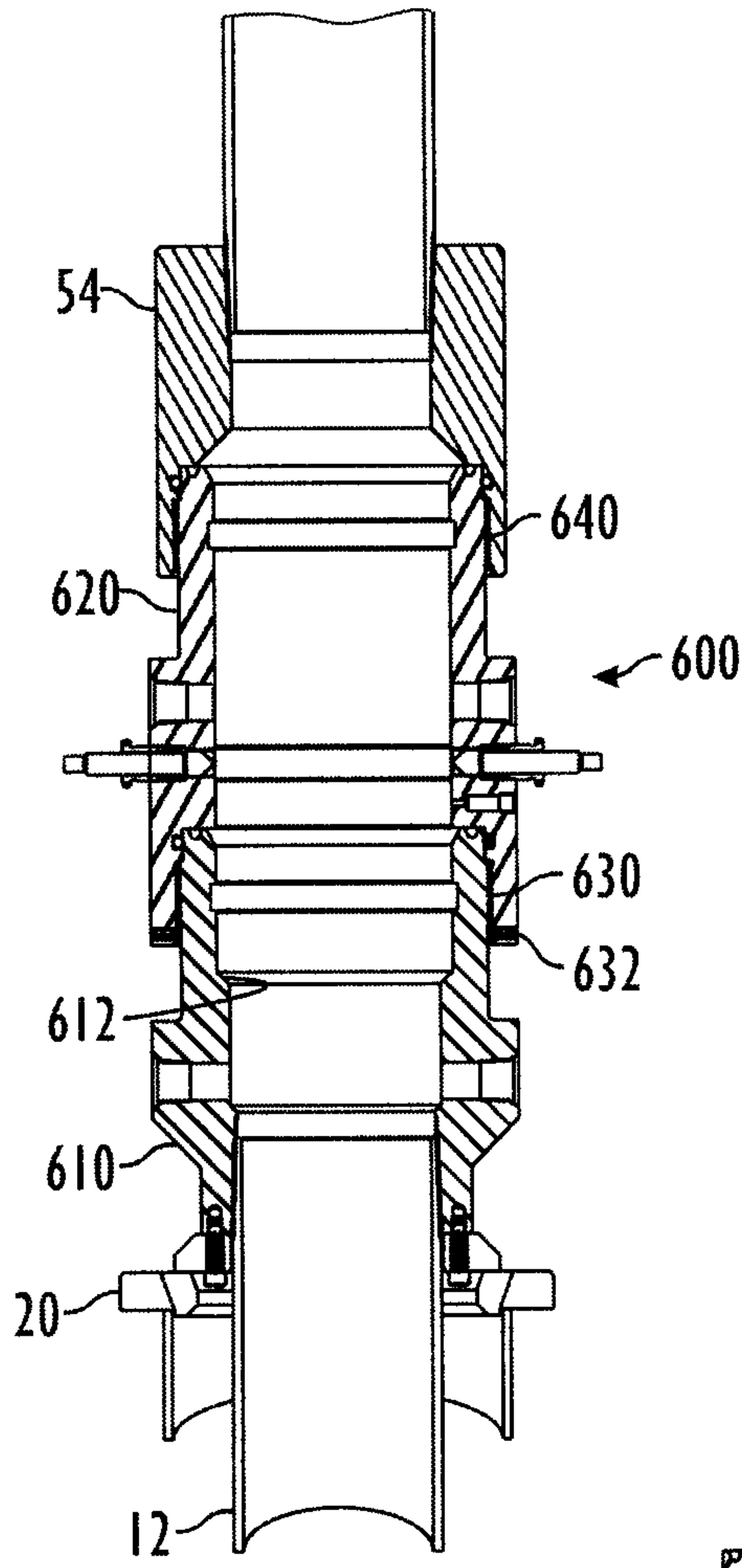

FIG. 11A

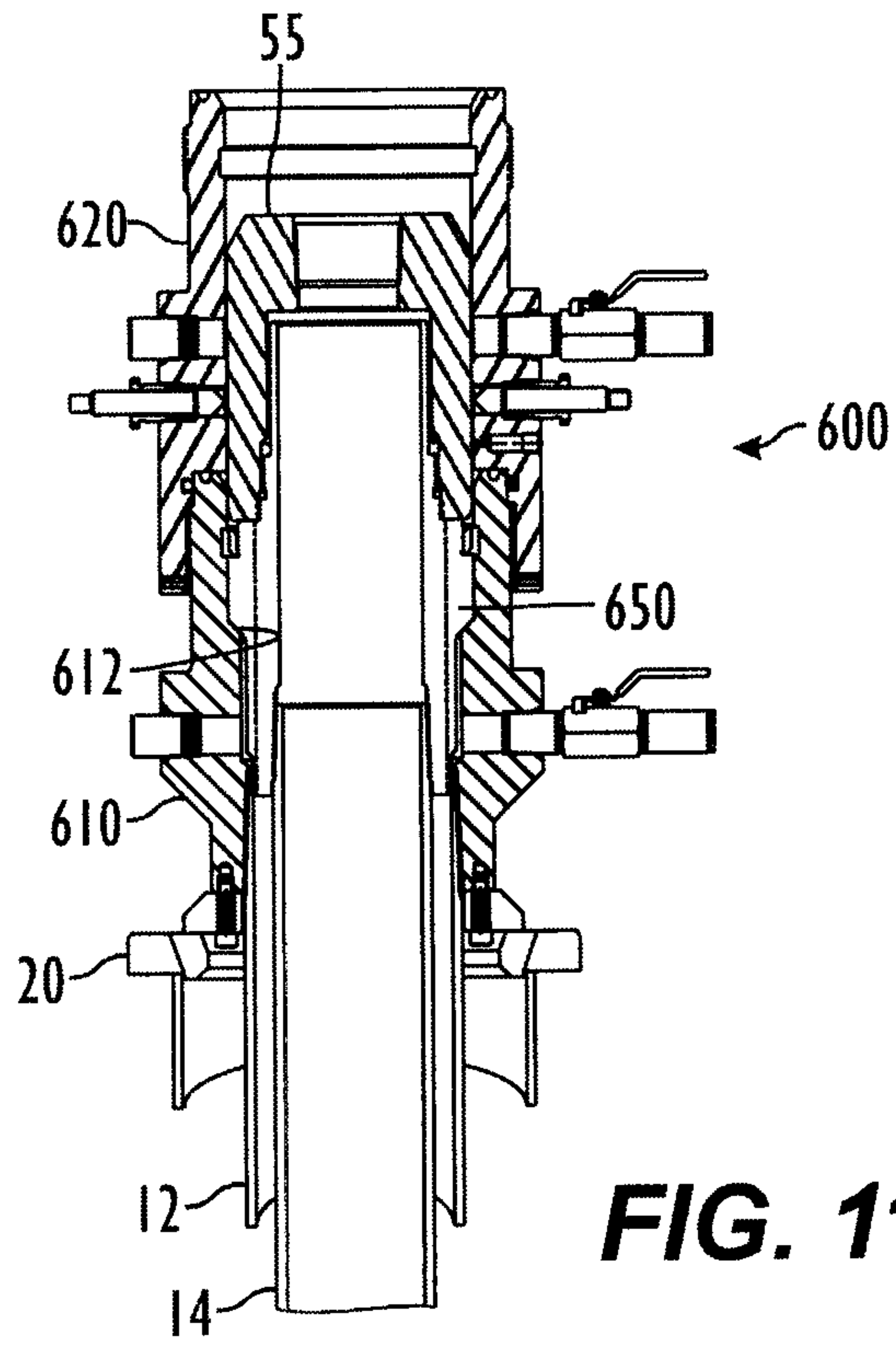

FIG. 11B

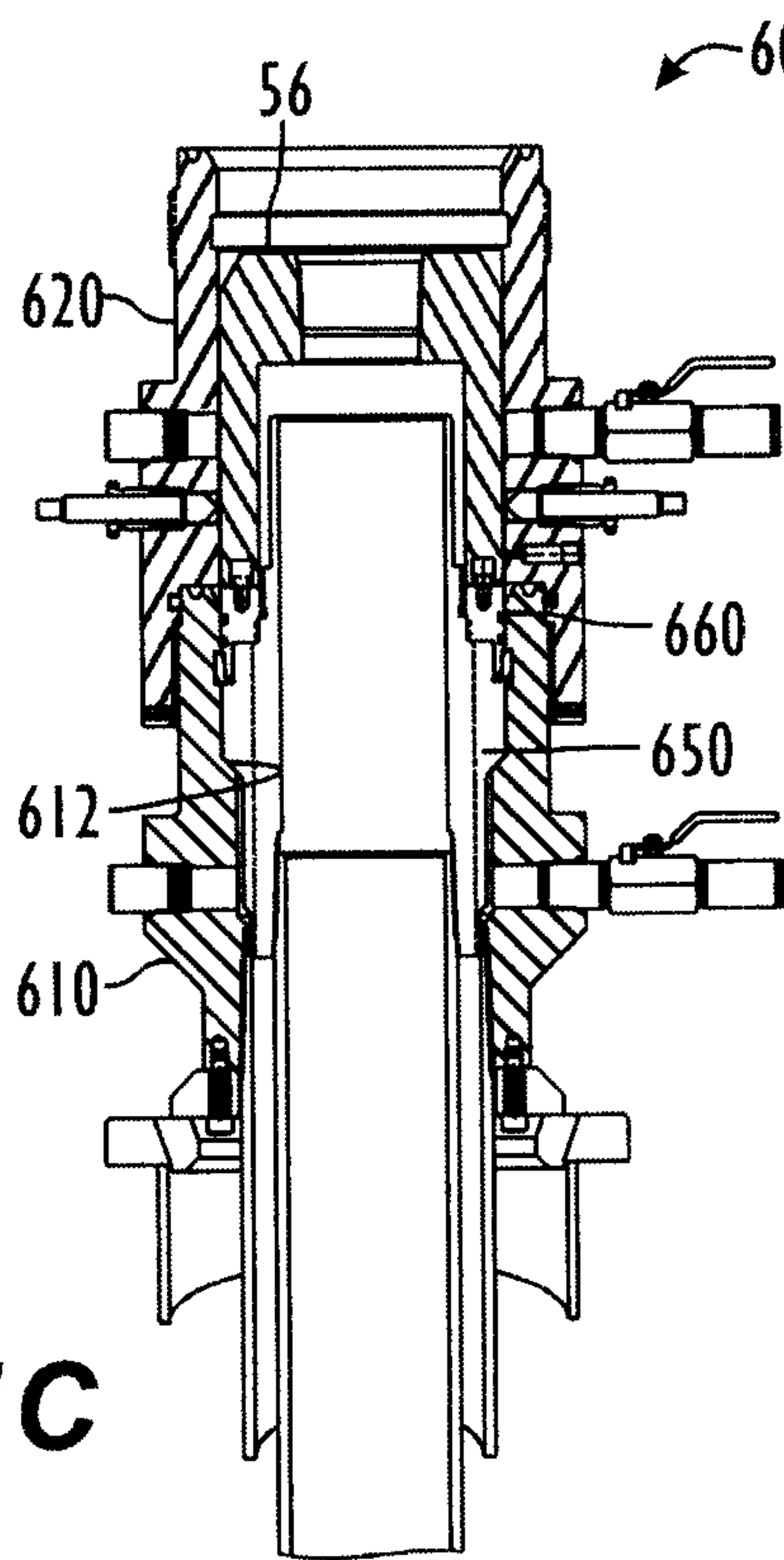

FIG. 11C

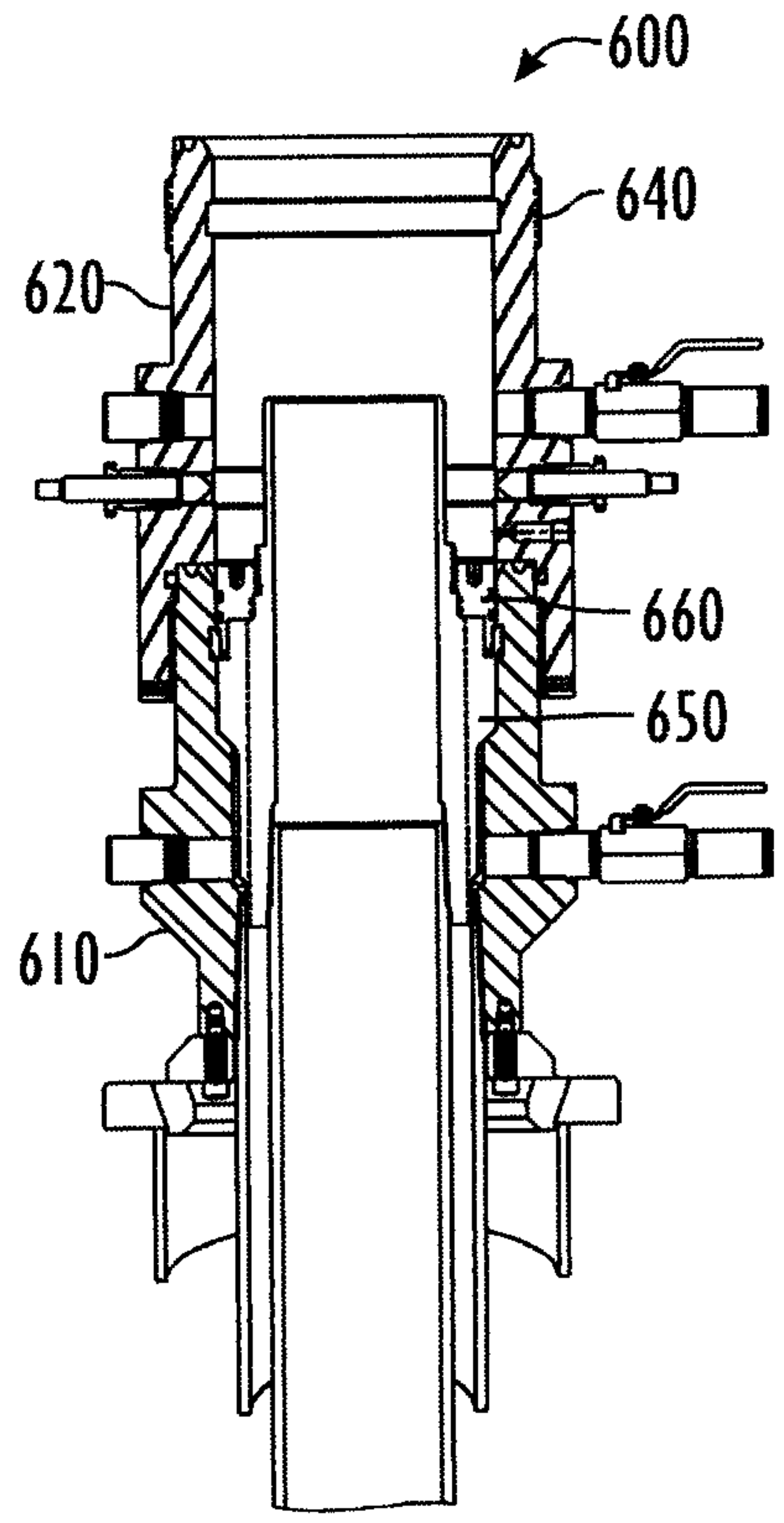

FIG. 11D

⊕

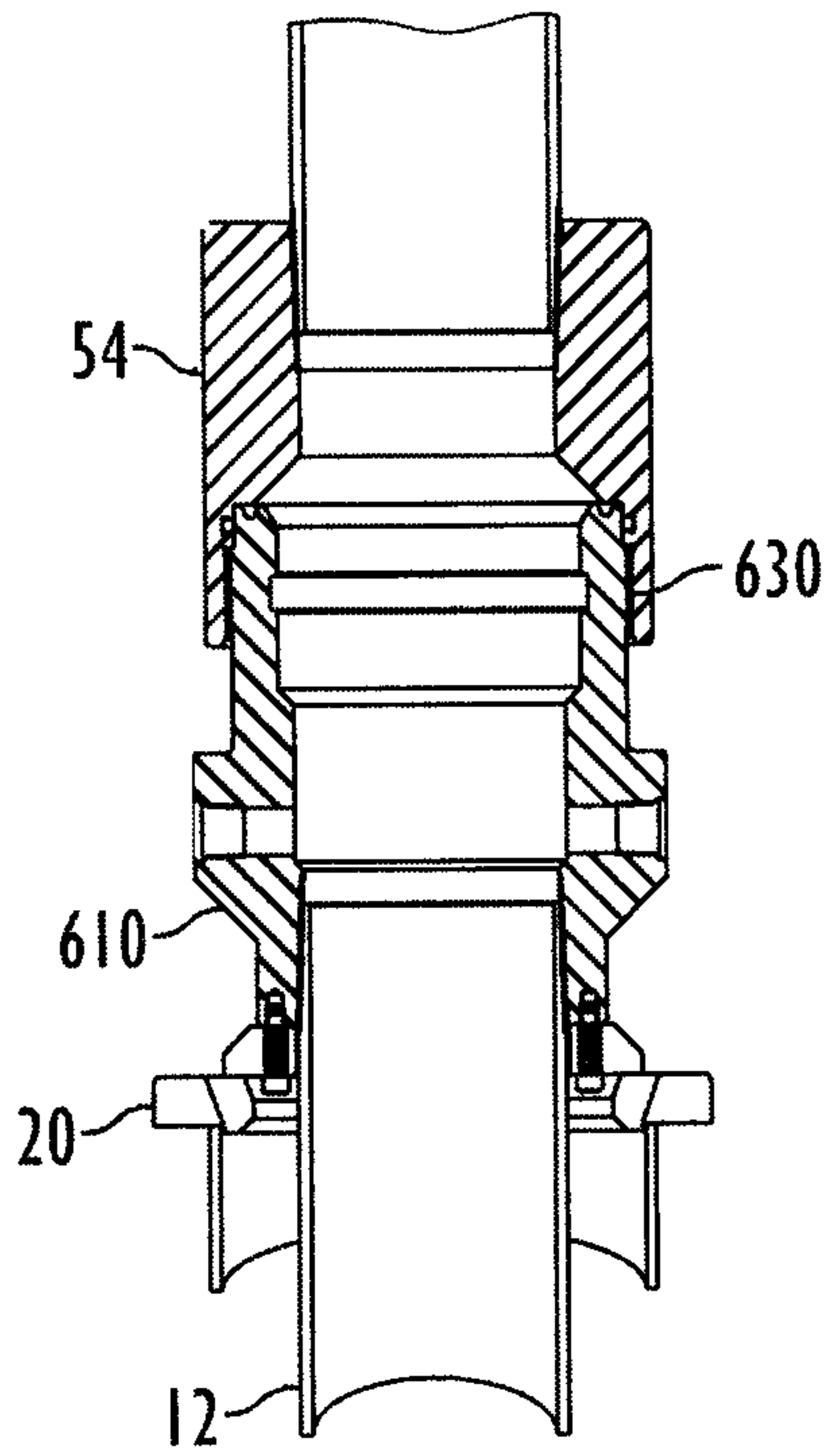

FIG. 12A

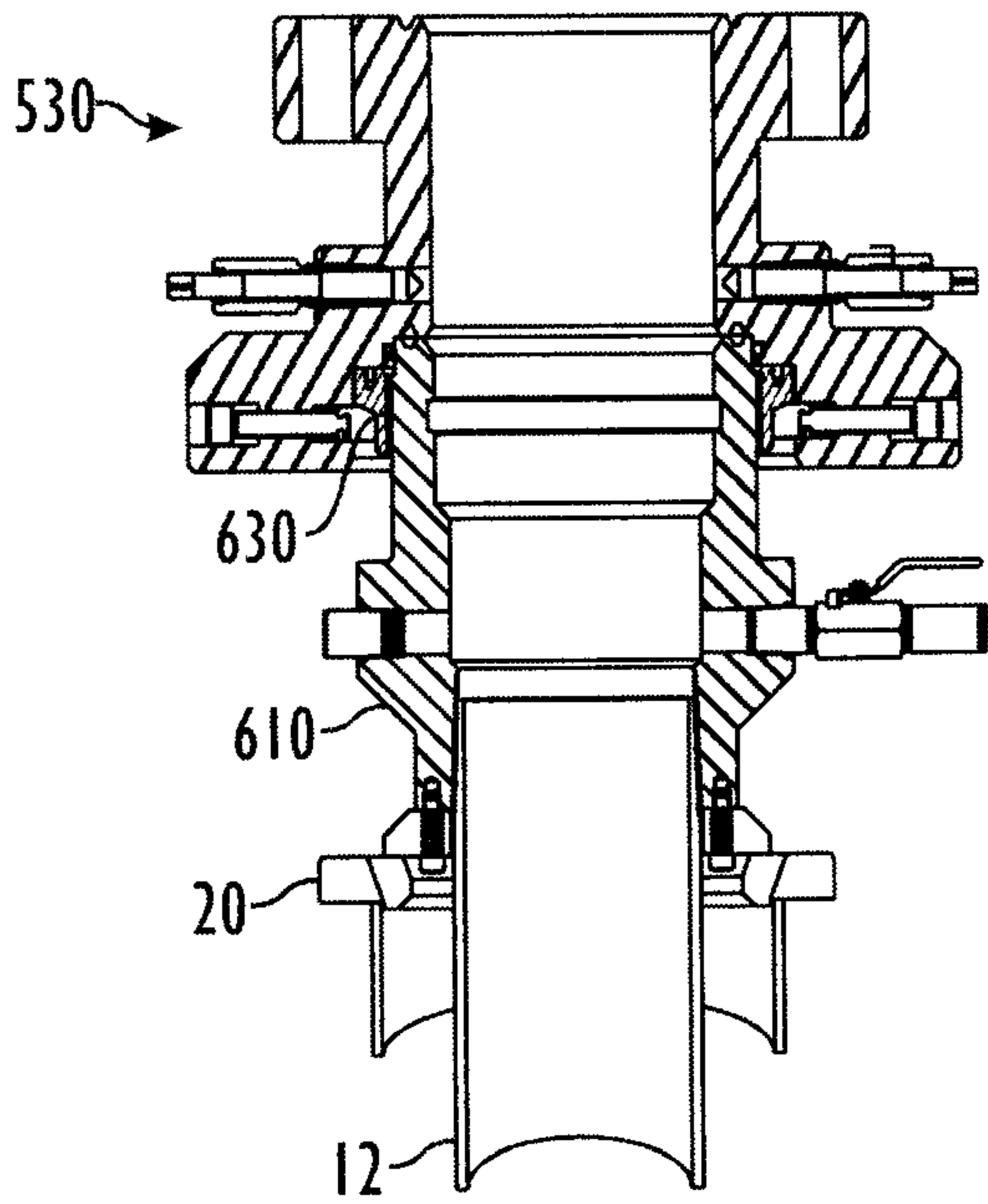

FIG. 12B

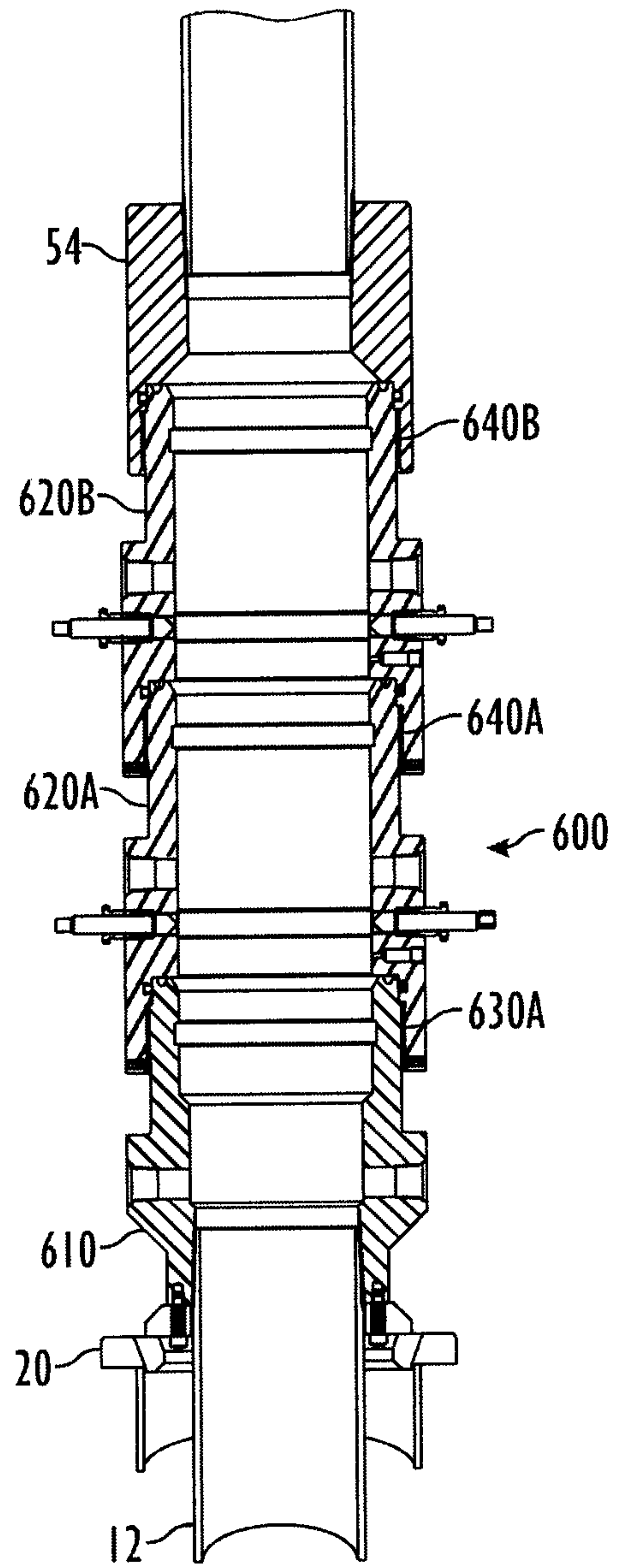

FIG. 13

9/9

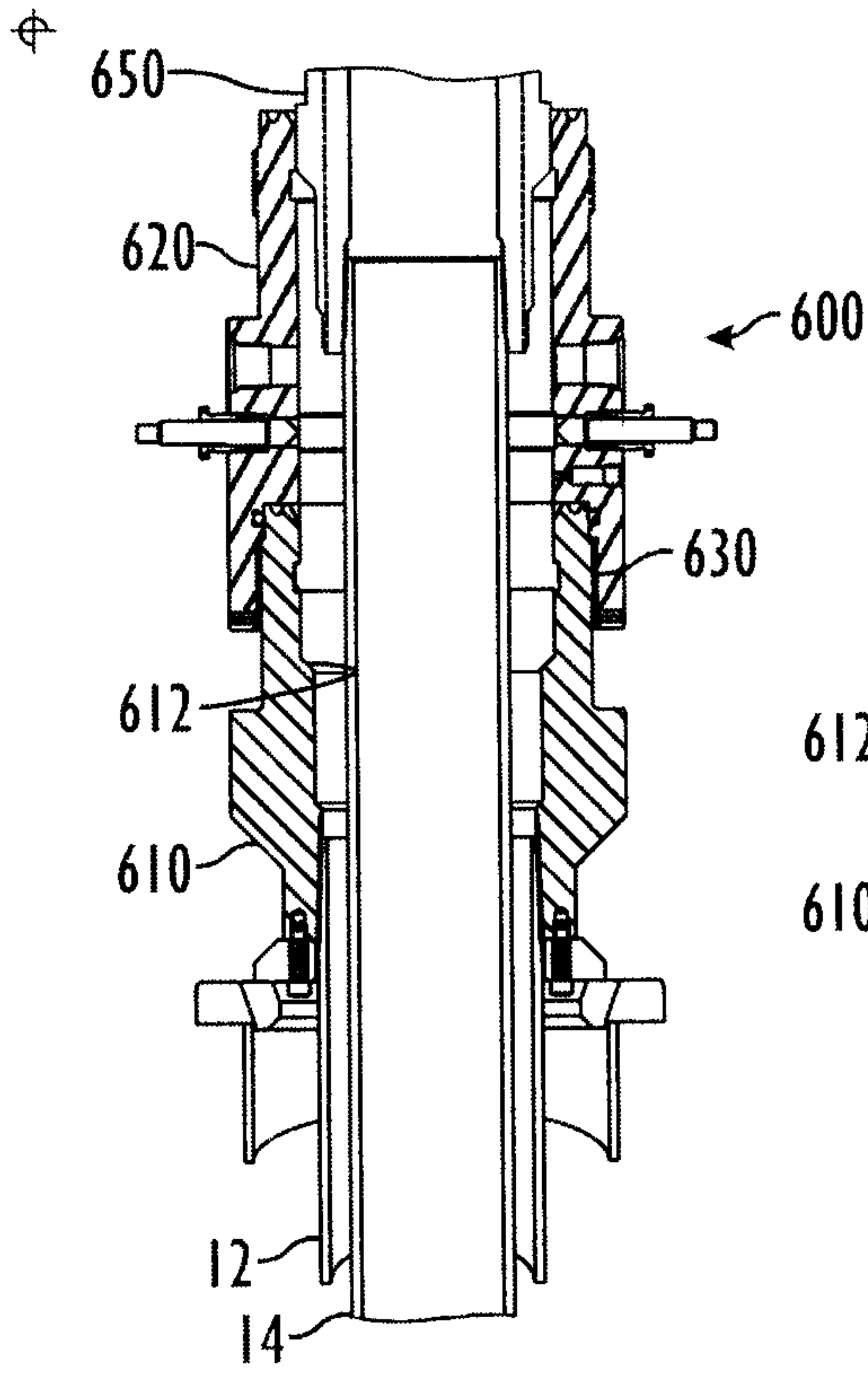

FIG. 14A

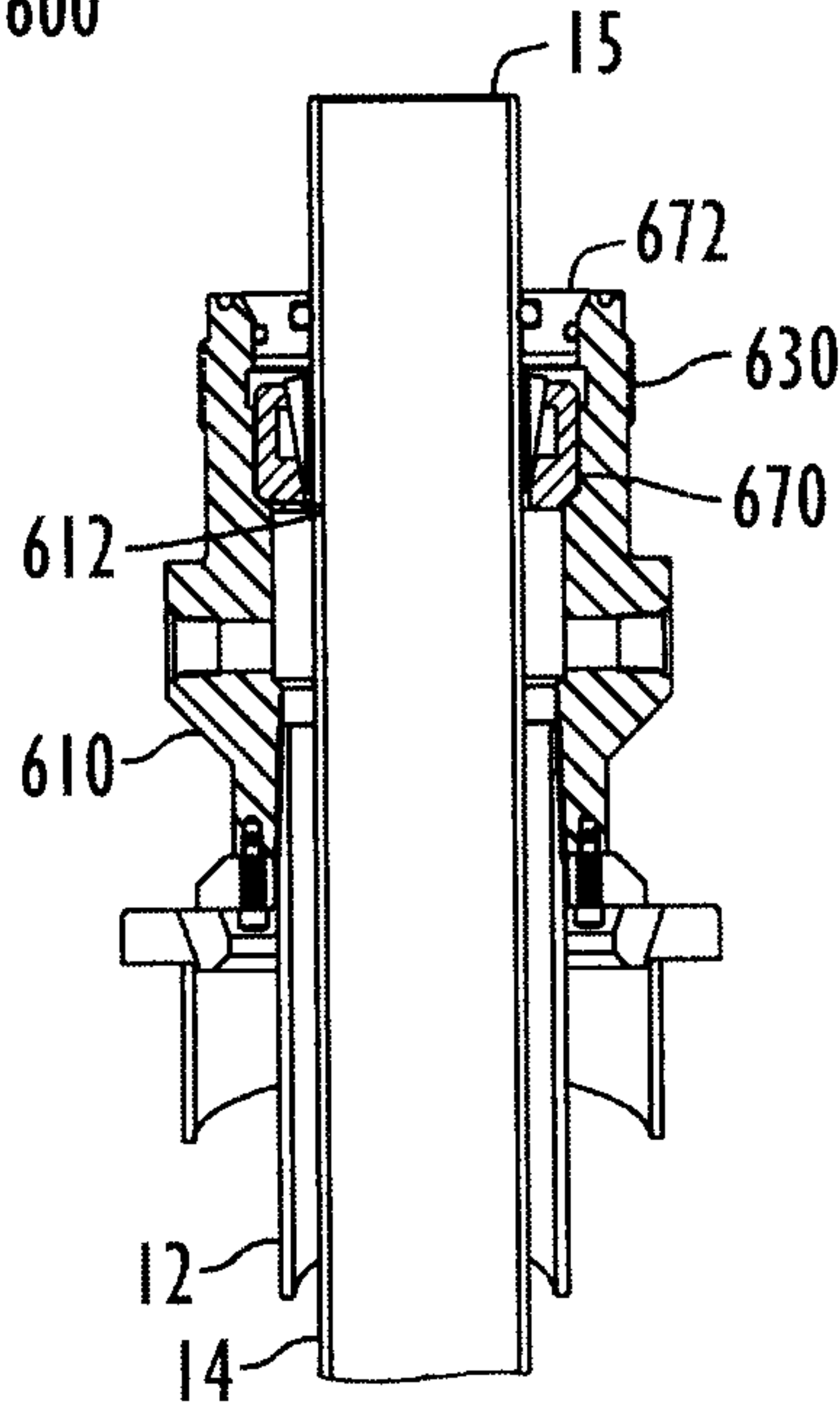

FIG. 14B

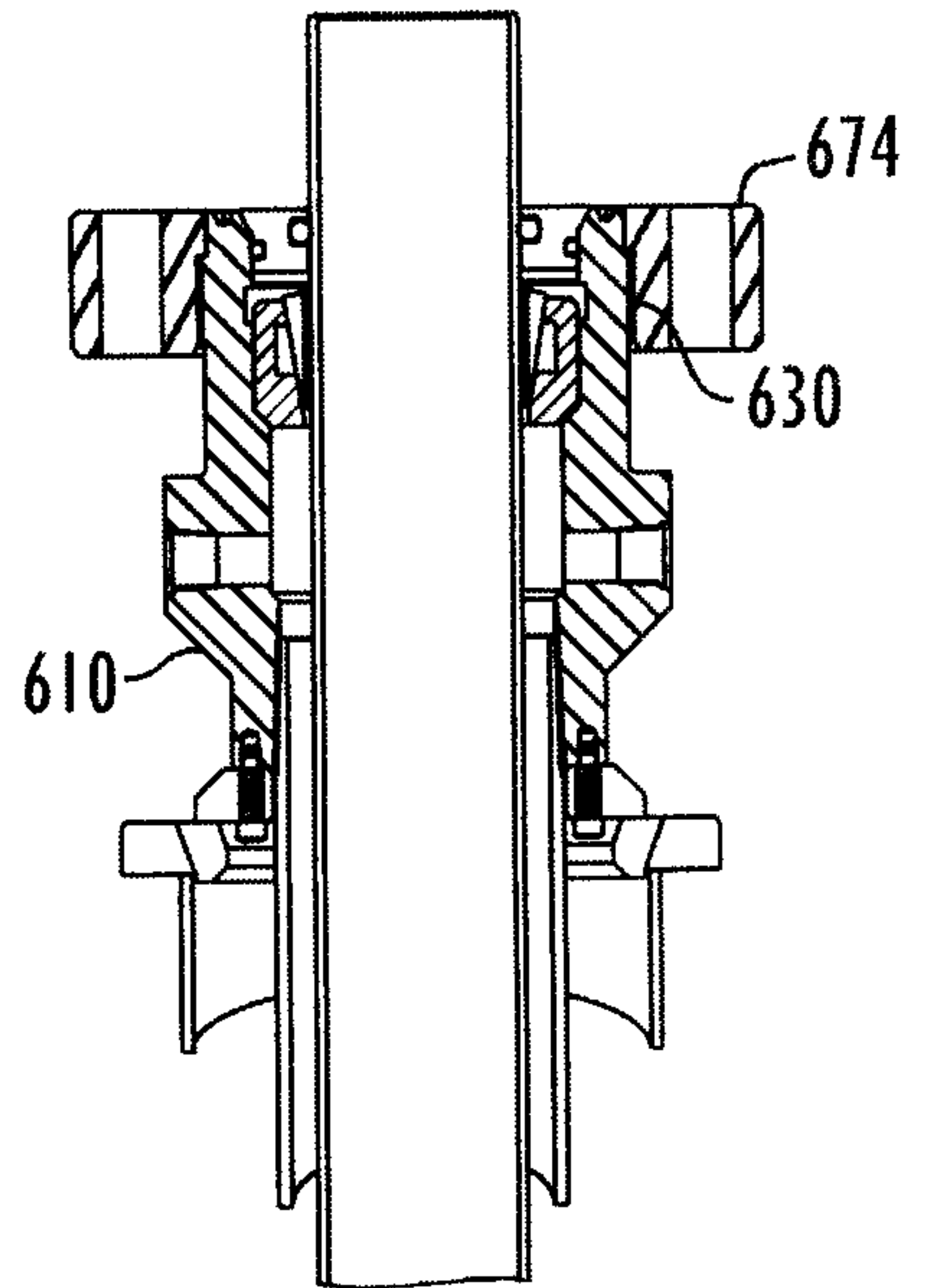

FIG. 14C

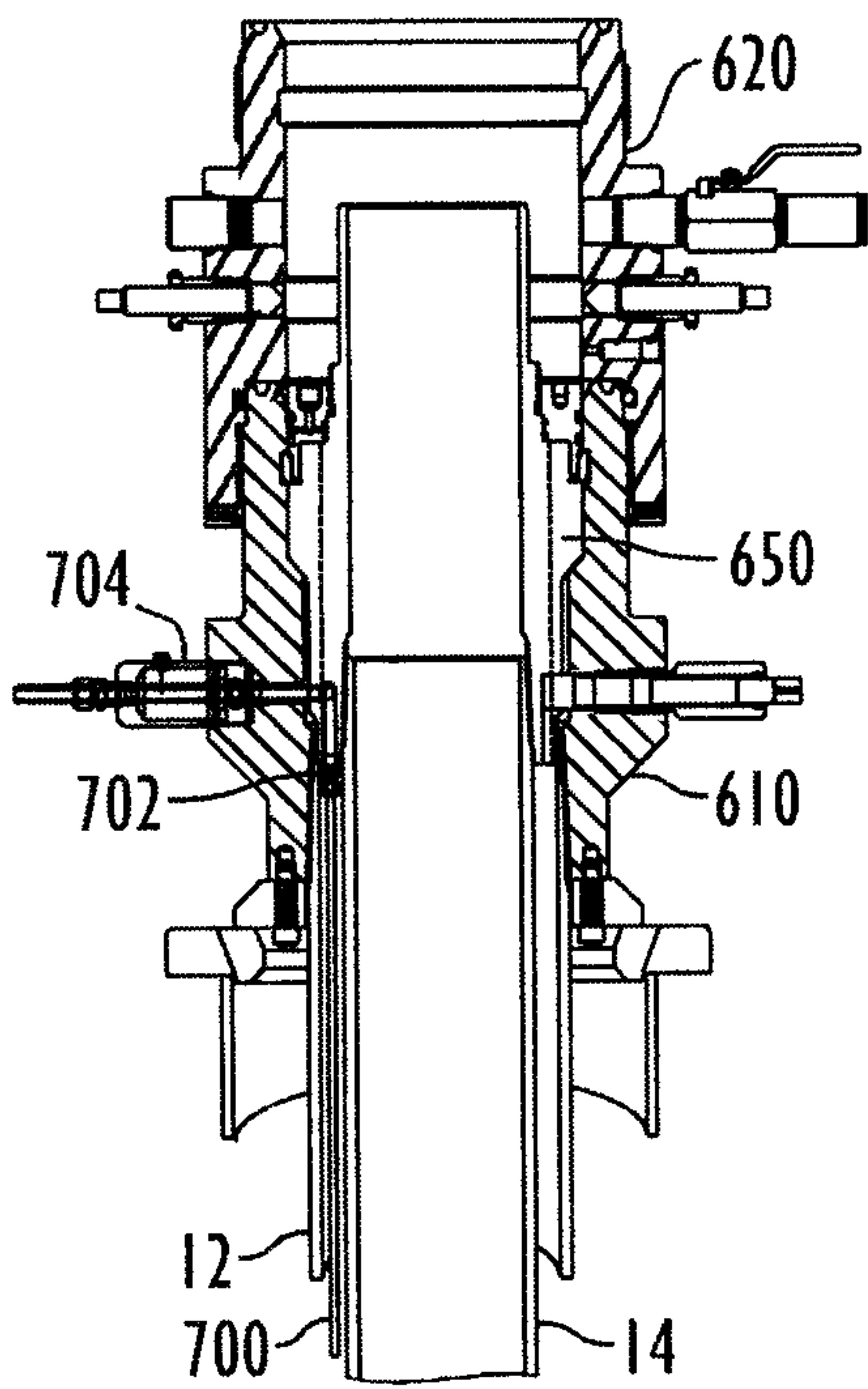

FIG. 15A

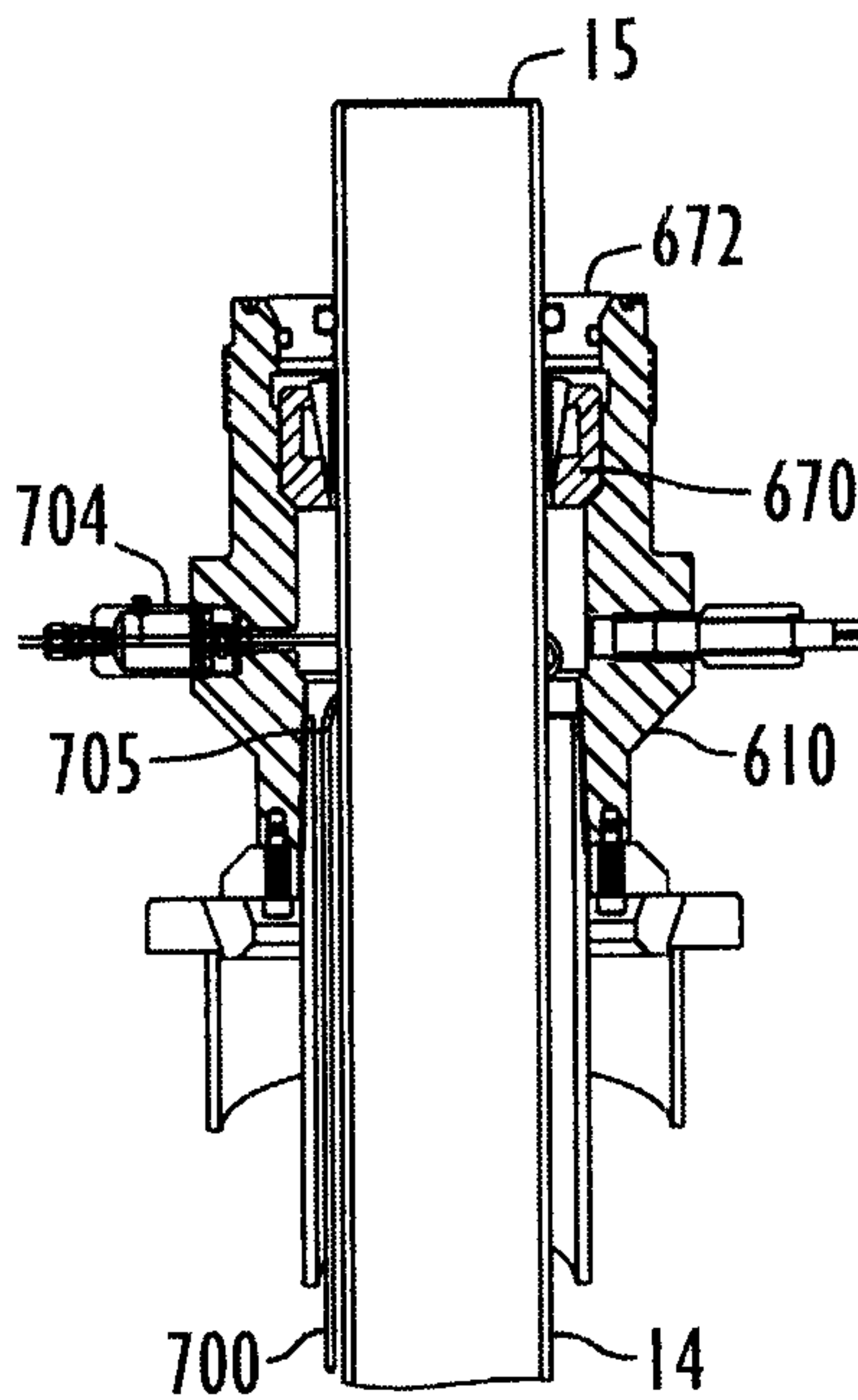

FIG. 15B

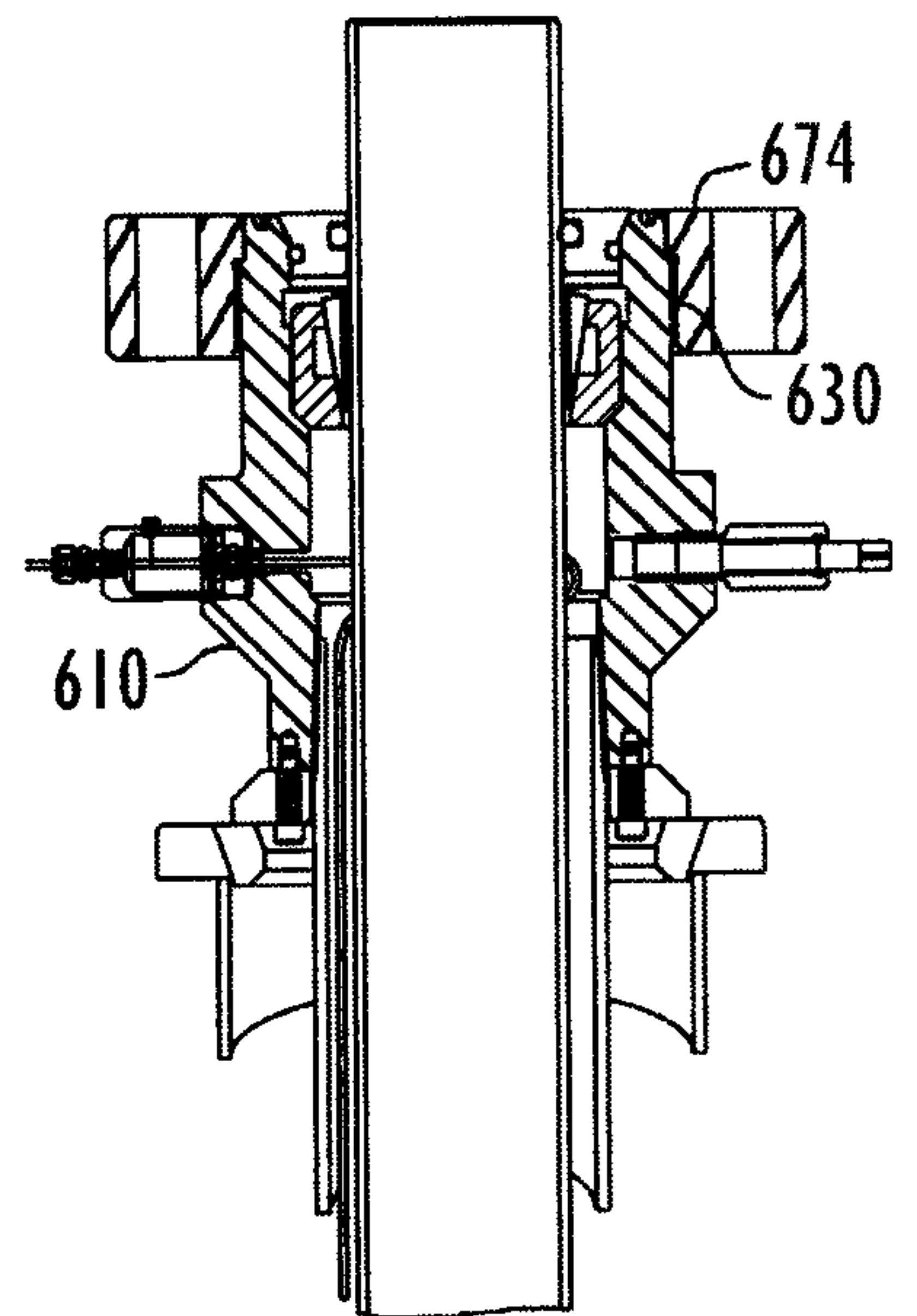

FIG. 15C

